



Colour and  
Landscape

# Proceedings of the International Colour Association (AIC) Conference 2019

**Buenos Aires, Argentina**  
14-17 October 2019  
Universidad de Belgrano

**Organized by**  
Grupo Argentino del Color  
(GAC)

**Published by**  
International Colour Association  
(AIC)

Colour and Landscape



# Proceedings of the International Colour Association (AIC) Conference 2019

Buenos Aires, Argentina  
14 – 17 October 2019  
Universidad de Belgrano

Organized by: Grupo Argentino del Color (GAC)  
Published by: International Colour Association (AIC)



grupo argentino del color  
international colour association





This publication includes invited lectures, oral and poster papers presented in the International Colour Association (AIC) Midterm Meeting 2019. The theme of the conference was Colour and Landscape. The conference, organised by the Grupo Argentino del Color (GAC), was held in the Universidad de Belgrano, Buenos Aires, Argentina, on 14-17 October 2019.

The original website of the conference was <http://aic2019.org>.

The contents have been moved to a more permanent site: <https://aic2019color.wordpress.com>.

**© 2019 International Colour Association (AIC)**

International Colour Association Incorporated

PO Box 764

Newtown, NSW 2042

Australia

[www.aic-colour.org](http://www.aic-colour.org)

All rights reserved.

**DISCLAIMER**

Matters of copyright for all images and text associated with the papers within the Proceedings of the International Colour Association (AIC) 2019 and Book of Abstracts are the responsibility of the authors. The AIC does not accept responsibility for any liabilities arising from the publication of any of the submissions.

**COPYRIGHT**

Reproduction of this document or parts thereof by any means whatsoever is prohibited without the written permission of the International Colour Association (AIC).

All copies of the individual articles remain the intellectual property of the individual authors and/or their affiliated institutions.

ISSN: 2617-2410

eISSN: 2617-2429

ISBN: 978-0-6484724-1-4

How to cite this book:

AIC (International Colour Association). 2019. *Proceedings of the International Colour Association (AIC) Conference 2019*. Newtown, NSW, Australia: AIC.

How to cite an article included in this book:

Author's name. 2019. Title of the article. In: *Proceedings of the International Colour Association (AIC) Conference 2019*. Newtown, NSW, Australia: AIC, page numbers of the article.



## Committees

### AIC Executive Committee 2018-2019

President:	Tien-Rein Lee (Taiwan)
Past President:	Nick Harkness (Australia)
Vice President:	Vien Cheung (UK)
Secretary/Treasurer:	Leslie Harrington (USA)
Committee Members:	Maurizio Rossi (Italy)
	Paula Csillag (Brazil)
	Takahiko Horiuchi (Japan)
	Ralf Weber (Germany)

### AIC 2019 Organizing Committee

<b>Chair:</b> María Paula Giglio (UN Mar del Plata)	José Luis Caivano (UBA & Conicet)
Laura Quaintenne (Buenos Aires)	Anahí López (LEMIT & UTN)
Gabriela Nirino (UBA)	Hugo Salinas (Conicet)
María Luisa Musso (UBA)	Germán Díaz Colodrero (U. Belgrano)
Cristina Vadji (UBA)	Mabel A. López (U. Belgrano)
María Inés Girelli (UN Córdoba)	Diana Moreno (U. Belgrano)
María M. Mariconde (UN Córdoba)	Rosario Villalón Abad (U. Belgrano)
Darío Suarez (UN Córdoba)	Logo design: Lucía Maillo (U. Belgrano)

### AIC 2019 Publications Committee

Proceedings editor:	José Luis Caivano
Graphic design:	Lucía Maillo Puente (logos, colors), Diana Moreno (cover and layout)
AIC 2019 website:	María Paula Giglio, José Luis Caivano
Book of abstracts:	José Luis Caivano, Diana Moreno (cover and layout)
AIC 2019 program:	José Luis Caivano, María Paula Giglio, Diana Moreno

### AIC 2019 Scientific Committee

<b>Chair:</b> José Luis Caivano	María Paula Giglio (Argentina)	Dimitris Mylonas (UK)
Kine Angelo (Norway)	Paul Green-Armytage (Australia)	Gabriela Nirino (Argentina)
Harald Arnkil (Finland)	Yulia A. Griber (Russia)	Katsunori Okajima (Japan)
Malvina Arrarte Grau (Peru)	Robert Hirschler (Hungary)	Galina Paramei (UK)
Ulrich Bachmann (Switzerland)	Takahiko Horiuchi (Japan)	Javier Romero (Spain)
Berit Bergström (Sweden)	A. Kwiatkowska-Lubańska (Poland)	Maurizio Rossi (Italy)
Charles A. Booker (Norway)	Jin-Sook Lee (Korea)	Tetsuya Sato (Japan)
Patrick Callet (France)	Anahí López (Argentina)	Verena M. Schindler (Switzerland)
Vien Cheung (UK)	Ming Ronnier Luo (UK)	Juan Serra-Lluch (Spain)
Elisa Cordero (Chile)	Maggie Maggio (USA)	J. Tarajko-Kowalska (Poland)
Paula Csillag (Brazil)	Manuel Melgosa (Spain)	Jinghong Wang (China)
Maria João Durão (Portugal)	Galen Minah (USA)	Ralf Weber (Germany)
Brian Funt (Canada)	María Luisa Musso (Argentina)	

## Organizing Institutions

On behalf of the International Colour Association (AIC), the Grupo Argentino del Color (GAC) is responsible for the organization of the AIC 2019 Midterm Meeting, at the Universidad de Belgrano (UB).



International Colour Association  
Internationale Vereinigung für die Farbe  
Association Internationale de la Couleur

The International Colour Association (AIC) is a learned society whose aims are to encourage research in all aspects of color, to disseminate the knowledge gained from this research, and to promote its application to the solution of problems in the fields of science, art, design and industry on an international basis. The AIC also aims for a close cooperation with other international organizations, regarding issues concerned with color. In 2009 the AIC agreed on the creation of an International Colour Day, which is celebrated in many countries around the world. Web: [www.aic-color.org](http://www.aic-color.org)



The GAC is a non-profit civil association that was created in Buenos Aires in 1980. Its aims are to encourage studies and research on color, and disseminate the results. Besides, the GAC promotes exchanges with other color associations, holds a specialized documentation center, and integrates various fields of color study in different areas: science, technology, art, design, industry, etc. The GAC is a regular member of the International Colour Association, and is the organization that represents Argentina in the AIC. Web: <http://grupoargentinodecolor.blogspot.com>  
Mail: [gac@fadu.uba.ar](mailto:gac@fadu.uba.ar)



Founded in 1964, the Universidad de Belgrano (UB), is a center of higher education. The UB distributes its faculties in the headquarters of Belgrano neighborhood, Buenos Aires. Studies comprise Architecture & Urbanism, Agricultural Sciences, Health, Economics, Exact & Natural Sciences, Law & Social Sciences, Humanities, Engineering & Information Technology, Languages & Foreign Studies. PhD, master, and specializations are offered in most of these fields, as well as in Business and Psychology. The university operates a radio station and features sports activities, with teams competing at inter-university level and sports leagues. Web: [www.ub.edu.ar](http://www.ub.edu.ar)

**Universidad de Belgrano (UB)**  
**Facultad de Arquitectura**  
**y Urbanismo (FAU)**

President: Dr. Avelino Porto  
Vice-presidents: Prof. Aldo J. Pérez / Dr. Eustaquio Castro  
Executive Directors: Dr. Marcela Porto / Lic. Ana Luisa Linares  
Dean, Fac. Arquitectura y Urbanismo: Prof. Mónica Fernández  
Director, Graphic Design career: Prof. Germán Díaz Colodrero

## AIC Regular Members

### Argentina

GRUPO ARGENTINO DEL COLOR

### Australia

COLOUR SOCIETY OF AUSTRALIA

### Belgium

INTERDISCIPLINARY COLOUR ASSOCIATION

### Brazil

ASSOCIAÇÃO PRÓ-COR DO BRASIL

### Bulgaria

COLOUR GROUP – BULGARIA

### Canada

COLOUR RESEARCH SOCIETY OF CANADA

### Chile

ASOCIACIÓN CHILENA DEL COLOR

### China

COLOR ASSOCIATION OF CHINA

### Croatia

HRVATSKA UDRUGA ZA BOJE

### Finland

SUOMEN VÄRIYHDISTYS SVY RY

### France

CENTRE FRANÇAIS DE LA COULEUR

### Germany

DEUTSCHER VERBAND FARBE

### Great Britain

THE COLOUR GROUP (GREAT BRITAIN)

### Hungary

HUNGARIAN NATIONAL COLOUR COMMITTEE

### Italy

GRUPPO DEL COLORE - ASSOC. ITALIANA COLORE

### Japan

COLOR SCIENCE ASSOCIATION OF JAPAN

### Korea

KOREAN SOCIETY OF COLOR STUDIES

### Mexico

ASOC. MEXICANA DE INVESTIGADORES DEL COLOR

### Norway

FORUM FARGE

### Portugal

ASSOCIAÇÃO PORTUGUESA DA COR

### Slovenia

SLOVENSKO ZDRUZENJE ZA BARVE

### Spain

COMITÉ ESPAÑOL DEL COLOR

### Sweden

STIFTELSEN SVENSKT FÄRGCENTRUM

### Switzerland

PRO/COLORE

### Taiwan

COLOR ASSOCIATION OF TAIWAN

### Thailand

COLOR SOCIETY OF THAILAND

### The Netherlands

STICHTING KLEURENVISIE

### United States

INTER-SOCIETY COLOR COUNCIL

## AIC Associate Members

INTERNATIONAL ASSOCIATION OF COLOR  
CONSULTANTS / DESIGNERS  
North America

COLOR MARKETING GROUP  
United States

## AIC Study Groups

COLOR EDUCATION (CE)  
Chair: Robert Hirschler (Hungary and Brazil)  
Co-Chair: Maggie Maggio (USA)

COLOR VISION AND PSYCHOPHYSICS (CVP)  
Chair: Katsunori Okajima (Japan)  
Secretary: Manuel Melgosa (Spain)

ARTS AND DESIGN (AD)  
Chair: Maria João Durão (Portugal)

ENVIRONMENTAL COLOR DESIGN (ECD)  
Co-Chairs: Verena M. Schindler (Switzerland)  
and Yulia A. Griber (Russia)

THE LANGUAGE OF COLOR (LC)  
Chair: Dimitris Mylonas (United Kingdom)  
Co-Chair: Galina Paramei (United Kingdom)

# Index of Contents

AIC president's message: Tien-Rein Lee .....	13
AIC past president's message: Nick Harkness .....	14
Color and Landscape, theme of the Meeting: María Paula Giglio .....	15
Preface: José Luis Caivano .....	16
Group photograph and program outline .....	17

## Plenary Lectures 18

---

Plenary speakers .....	19
Robert Hirschler:	
Colour theory and neo-impressionist landscapes .....	20
Paula Csillag, Ana Lucia Lupinacci:	
Landscapes used in design and art: the work of Fred Jordan, the Brazilian master of color .....	32
Zena O'Connor:	
Effective environmental visual literacy: pedestrian crossing design and the key roles of colour and contrast .....	41
Ming Ronnier Luo:	
A summary of the parametric studies on colour difference evaluation .....	48
Verena M. Schindler:	
Jean-Philippe Lenclos' methodology of "The Geography of Colour": back to the origins and its international impact .....	54
Judd Award Lecture	
Citation, by Ming Ronnier Luo .....	64
Lecture: Hirohisa Yaguchi:	
Individual color vision .....	66
Color in Art and Design Lecture	
Citation, by Vien Cheung .....	76
Lecture: Roy Osborne:	
Renaissance colour symbolism .....	78

## Art and Design 91

---

Alex Booker, Kine Angelo:	
Colour and place making; an artist's influence on spatial production .....	92
Elisa Cordero-Jahr, Javiera Muñoz, Daniela Caro, Marjorie Delgado:	
Watercolor: a powerful tool to study the colors of the landscape .....	99
Lilian Walker:	
Between skin and landscape: color as a mimetic agent .....	105
Maryam Alsadat Mirian, Forough Mahyar:	
Colours of clothing as a factor influencing the colour scape of cities .....	111

Varinnia Jofré: Cesia in nature and in the representation of nature. Luminous cesia: a special case .....	117
Pedro Felipe Pinho Souza: Color in the representation of homosexuality in the films <i>A single man</i> , <i>Blue is the warmest color</i> , and <i>Moonlight</i> .....	124
Leonard Echagüe: Painting, landscape, cinema and color .....	131
Francis Rodrigues da Silva, Luciana Martha Silveira: Hybrid views: color in Brazilian landscape painting in the beginning of the 21st century .....	139
Malvina Arrarte-Grau: Timelessness and temporality of landscape colours .....	145
Alfonso de Lucas Tron: Evident color and underlying color. A color constancy approach .....	153
Gyeonghwa Lee, Vien Cheung, Tang Tang, Stephen Westland: Designers' experience and use of colour information .....	162
Gabriela Nirino, Cecilia Dorado, Daniela Tosar, Julia Feldman, Josefina Alvarez Gardiol: Color and landscape in textile design .....	168
Ahmed Nasseraldin, Stephen Westland, Jamie Marsden: The role of colour in a successful logo .....	171

## Ambiences Seminar 176

---

Ferre Alpaerts, Inez Michiels: The semantic color space .....	177
Imara A. M. Duarte, Carla P. A. Pereira: Perception, color and user experience: a study in a hospital environment of hemodialysis .....	183
Aiping Gou, Jiangbo Wang: Correlation analysis of color and function of urban architecture: taking Shanghai as an example .....	189
Jiangbo Wang, Aiping Gou: A study on the fragmentation measurement of color space in historic areas: a case study of the old city chamber in Shanghai .....	193
Kazim Hilmi Or: Some flying ideas about color and light ambiances in built and natural environments .....	197

## Color and Psychology 199

---

Jing Lin, Stephen Westland: Effect of intensity of short-wavelength light on human alertness .....	200
Mahshid Baniani: Color preference and emotion among Japanese students .....	205
Tzu Hao Liu, John Hutchings, Ming Ronnier Luo: A method for scaling impressions of a scene .....	211



Saori Kitaguchi, Yoshikazu Mizutani, Sumako Suzuki, Tetsuya Sato: Colour influence of input button on user's pressing motivation: analysis using different background colour and shape of button .....	217
Paru Kondo, Midori Tanaka, Takahiko Horiuchi: Memory effects for metallic colored objects in different memory periods .....	223
Ruolin Gao, Haiwei Yan: Research on the influence of children's building block color on children's learning process .....	228
Haiwei Yan, Ruolin Gao, Yuanbo Sun: The effect of the number of colors in teaching blocks on children's learning .....	234
Kazim Hilmi Or: How could the colour "blue" become a "cool/cold" colour? .....	239
Mabel Amanda López: "Skin color" or colors of skin? The faces of violence in children's drawings .....	242

## Color, Language and Culture 248

---

Ivar Jung, Yulia A. Griber: Colour associations for the words feminine and masculine in nine different countries .....	249
Daniela Evangelina Chazarreta: Colour and landscape in Octavio Paz's <i>Libertad bajo palabra [Parole]</i> (1935-1957) .....	255
Yulia A. Griber, Galina V. Paramei, Dimitris Mylonas: "Edible" colour names: age-related differences in Russian .....	256
Renata Pompas, Lia Luzzatto: Black, white and red: archetypes and symbols .....	263
Lorena Pepa, Analía Rodríguez, Cristina dos Santos, Guillermo Hough, Luis Panizzolo, Pilar Buera: <i>Dulce de leche</i> as part of the gastronomic landscape of Río de la Plata .....	270
Julieta Gabilondo, Lorena Pepa, Aldo Fernández-Varela, Nicolás Villagrán dos Santos, Lucía Talevi, Fabiano Freire-Costa, Analía Rodríguez, Cristina dos Santos, Verónica Busch, Abel Farroni, Luis Panizzolo, César Cortés, Pilar Buera: Color identity in South American natural landscapes: herbs, flowers and fruits crops .....	273
Verónica Conte: Colour and art shaping contemporary landscape dimensions .....	276
Yosuke Yoshizawa: Decision of validness in custom color names of JIS Z 8102: case of Japanese color names .....	284
María Paula Giglio: "Color and landscape" in our eyes: collective project 2019 of the Grupo Argentino del Color (GAC) .....	289

## Light and Color 291

---

Coralie Cauwerts, Sophie Jost: Color rendering of window glass: analysis of the occupant's view with hyperspectral imaging .....	292
Mai Minami, Toshiki Torimitsu, Nozomu Yoshizawa: Quantitative condition for making the appearance of fluorescence in actual architecture using chromatic light .....	298
Guobin Xia, Phil Henry, Francisco Queiroz, Stephen Westland: Effects of object colour stimuli on human brain activities and subjective feelings in physical environment and virtual reality .....	304
Mariana Noguera, João Pernão: Colour and light in exterior architectural illumination: from efficiency to aesthetics .....	311
Carlos Colonna, Pablo Ixtaina, Agustín Pucheta: LEDs and urban landscape .....	317
María Paula Giglio: Dynamics of color and cesia in the urban landscape: transience and perception of differences .....	324

## Architecture and Landscape 326

---

Kine Angelo, Alex Booker: C > 0 – Traditional façade neutrals are not achromatic .....	327
Juana Gandino, Rocío Melman, Ludmila J. Paroldi Algranati, José Luis Caivano, Gabriela Cárdenas, Roberto Lombardi: <i>Clorindia domestica</i> . Studies of architectural chromatic organization in relation to landscape .....	333
Martin Huwiler, Cornelia Gassler: Colour in relation – Relations between the perception and design of architectural surface and its context .....	340
Per Jutterström: Good or bad, nice or ugly? – Some exterior colour design by private homeowners in the northern part of Sweden .....	347
Jie Yang, Stephen Westland, Kaida Xiao: Deriving colour palettes from images of natural landscapes .....	351
Anahí López, Alejandro R. Di Sarli: Impact of concrete in the built landscape .....	357
Rui Barreiros Duarte: Urban attractors: color and sustainability .....	363
María Marta Mariconde, María Inés Girelli, Raúl Darío Suárez: Chromatic design in the natural landscape. University student residence in the Campo Escuela FCA-UNC, Córdoba, Argentina .....	369
Nathalia Teixeira Gnutzmann, Natalia Naoumova, Adriane Borda Almeida da Silva, Sandro Martinez Conceição: Luis Barragán among colors and forms: a case-study on project strategies in three of the architect's works .....	372
Ana Paula Pinheiro: The color of roofs and sustainability .....	378

## Urban Landscape

383

Raúl Darío Suárez, Carlos Augusto Zoppi: The relevance of light and colour in current architecture: possibilities and challenges .....	384
Larissa Noury: Colour harmony: landscape and city .....	390
María Luisa Musso: Colors in the landscape of Buenos Aires .....	396
Anahí López, Alejandro R. Di Sarli, Luis P. Traversa: Architectural landscape built by Francisco Salamone. State of conservation of tiles located in Azul city, Buenos Aires province, Argentina .....	402
Jada Schumacher: Postcards from chromatic places (from Golden, Colorado, to White Settlement, Texas) .....	408
Sara Leonor Kenny, María Inés Girelli: Inherent and perceived colour: Bolivia-La Paz-Copacabana .....	418
Cristina Caramelo Gomes, Catarina Diz de Almeida, José Afonso: Lisbon: the colour of change .....	421
Kiwamu Maki: Making color palettes for multi-unit apartment buildings based on the building color survey in Japan, Portugal, and The Netherlands .....	428
Yen-Ching Tseng, Yuh-Chang Wei, Monica Kuo, Ya-Ping Kuo, Wen-Guey Kuo: A case study on environmental landscape color harmony via the Zhengbin Fishing Port color scheme .....	434
Catarina Diz de Almeida, Cristina Caramelo Gomes, José Afonso: Colour functions in urban design: communication, identity and user behaviour .....	441
Natalia Naoumova, Marina Mendonça Loder: Color and housing: a study of the chromatic aspects of the social mass housing complexes .....	448
Alberto Reyes González, Andrés Enrique Reyes González, Jimena Vanina Odetti: The chromatic intervention as a proposal of urban image design for university contexts: the case of Coapinole, Puerto Vallarta, Jalisco, Mexico .....	454
Hongyu Guo: The extraction and application of regional features of urban colors: On China's urban color planning strategy in the context of globalization .....	461
Vanessa Peres Martins, Natalia Naoumova: Color and heritage: analysis of the evolution of the methodology used in Italian color plans .....	468
María Marta Mariconde, María Inés Girelli, Raúl Darío Suárez, Marcelo Balián, Sara Leonor Kenny, Laura Suez, Marcos Barboza, Roberto Ferraris, Victoria Ferraris, Beatriz Ojeda: Color ideas. Urban chromatic actions from teaching .....	475

## Color Education 480

---

Edda Mally, Jin Hee Lee: IACC colour training —IACC Academy Salzburg, Austria .....	481
Marjan Kooroshnia: Challenging current colour theory and practice using thermochromic and photochromic inks in textile design .....	488
Natacha Le Duff, Anne Cogan-Krumnow: Presenting colours in a museum: mediation and scenographic principles .....	500
Tien-Rein Lee, Wen-Yuan Lee, Pei-Li Sun, Tsuei-Ju Hsieh: Assessing the color learners' competence in multiple topics of essential color knowledge .....	508
Zena O'Connor: The Shillito Design School: an influential colour curriculum with historical links to the Bauhaus .....	513
Zena O'Connor: Colour harmony: a 2020 perspective .....	520
Glenn McArthur: Local colour and patterns .....	527
Maurizio Rossi, Ingrid Calvo Ivanovic, Alessandro Rizzi: Project work experiences in post-graduate education on color design .....	532
Alessandro Rizzi, Alice Plutino, Maurizio Rossi: Fundamentals of color teaching in post-graduate education .....	538

## Environmental Color Design 543

---

Verena M. Schindler, Yulia A. Griber, Martine Bouchier: The French period in the history of environmental colour design .....	544
Natalia Naoumova, Maria Cristina Dias Lay: Chromatic identity of urban historical settings: chromatic typology analysis .....	550
Carlos Mario Rodríguez, Elisa Teresa Violante: Color territories: the colors of Boyaca, a palette for its identity .....	556
Anamaria Rezende, Nivia B. Ferreira: Color, identity and space in digital games .....	561
Juan Serra-Lluch, Javier Cortina-Maruenda, Ana Torres-Barchino: Color in residences for the elderly: ideas competition for scholars .....	562
Ana Torres-Barchino, Juan Serra-Lluch, Anna Delcampo-Carda: Chromatic applications in interior spaces for the elderly in the P. Borja Geriatric Center of the Fontilles Foundation .....	568

## Color Vision and Psychophysics 574

---

Kota Akiba, Midori Tanaka, Takahiko Horiuchi: Experimental consideration on the effect of ipRGC for color reproduction on display device .....	575
--	-----

Yasuki Yamauchi, Tomonori Tashiro, Yuki Kawashima, Atsushi Konno, Kunihiro Hatakeyama, Takehiro Nagai: Do color matching functions explain individual differences in color appearance? .....	580
Raju Shrestha: A framework and methodology for spectral color vision deficiency imaging .....	586
Hiroshi Takahashi, Daisuke Saito: Influence of the color of lighting on taste threshold .....	594
Pablo A. Barrionuevo, Dingcai Cao: Does melanopsin help to explain color constancy in natural environments? .....	598
Andrés Martín, Juan Ignacio Contino: Pupil role in color brightness perception in relation with “the dress” explanations .....	605
Shogo Nishi, Takuto Katanozaka: Improving the appearance of HDR images based on visual characteristics .....	609

## **Color Science and Technology** 613

---

Yuki Akizuki, Takahiro Goto, Futoshi Ohyama, Satoshi Iwamoto: Color reproduction problems of telemedicine with the use of smartphone .....	614
Chelsea Sullivan, Stephen Westland, Roger Ellwood: Comparison of colorimetric data from spectroradiometers and spectrophotometers .....	619
Kazim Hilmi Or: Metamaterials: “Lenses” without chromatic aberration? .....	626
Andrés Martín, Bárbara Silva, Cecilia M. Lasagno, Víctor Novello, Sergio Gor: What is the goal of the wine chromatic characterization in a CIE color space? .....	630
Leyanet Barberia-Roque, Erasmo Gámez Espinosa, Marisa Viera, Natalia Bellotti: Prevention of the color changes in waterborne antimicrobial coatings with nano- functionalized siliceous filler .....	634
María Leonor Sandoval Salinas, José D. Sandoval, Elisa M. Colombo, Rubén M. Barquez: Common patterns of color change related to sex, season and latitude in small mammals museum specimens .....	639

## **Appendix** 646

---

Posters that received the Robert W. G. Hunt Poster Award (provided by The Colour Group, Great Britain) .....	647
Exhibition: Color exercises by graphic design students of Dutch art faculties (by Julieta Garavaglia) .....	651
Exhibition: The Biosphere Project (by Joaquín Fargas) .....	652
<b>Index of Authors</b> .....	653

## AIC president's message

### Tien-Rein Lee



Dear members of the AIC, dear color friends!

It's time again to celebrate another wonderful event of our international color society:

The AIC 2019 Midterm Meeting is being held in Buenos Aires, Argentina, from 14-17 October, under the brilliant topic: "Colour and Landscape". So I'd like to send out a very warm welcome to all scientists, artists and friends of the worldwide color research and arts communities, and I sincerely hope that we will share this opportunity to meet on common ground for an intense exchange of many different views and perspectives!

It is to my great pleasure that we can announce this conference as a real high-profile expert gathering, offering a range of 21 topics in 10 fields of color research, plus forums led by AIC Colour Association's study groups. The Judd Award will be presented to Prof. Hirohisa Yaguchi, Chiba University / Japan; and the AIC CADE Award will be given to Prof. Roy Osborne, artist, educator and writer / UK. We are also looking forward to five plenary lectures and an exhibition. With such an attractive program and several highlights coming up, I have no doubts that we are going to enjoy a most exciting and interesting event!

So, let me express my deep gratefulness to the organizing and scientific committees, and to everybody who has worked hard to realize this Midterm Meeting. I am sure that those great efforts will be honored as a substantial contribution to the world of color research and color arts, and that its conference findings is going to have a lasting impact on all fields of color expertise. Thank you very much!

In addition to the multifaceted professional program, the program also includes highly attractive cultural activities that shouldn't be missed —the excursion to the town of Tigre on the Parana river, and a banquet with tango performance. Let's all join in and take part in this special experience, providing us with a taste of original Argentinian culture!

I wish everybody a fantastic time in Buenos Aires!

Tien-Rein Lee  
President, Association Internationale de la Couleur

September 2019

## **AIC past-president's message**

### **Nick Harkness**



Dear Friends

Colourful greetings and welcome to AIC 2019 Colour and Landscape. Firstly, a big thank you to Maria Paula Giglio and the team from Grupo Argentino del Color for organising this AIC event. The level of commitment required (all voluntary) to hold an AIC meeting is enormous.

It is nine years since we last met in Argentina at Mar del Plata June 2010. Welcome back this time to the colourful city of Buenos Aires. In 2016 we also met in South America in the vibrant city of Santiago de Chile with of course a side trip to colourful Valparaiso.

The topic for this meeting is very timely with so much environmental destruction. The rain forest of the Amazon, the lungs of the planet are being decimated by fires. They generate around 20% of the oxygen in the atmosphere and store greenhouse gases such as carbon monoxide. Adding to which the increasing loss of the polar ice caps and shrinking glaciers, have an exponential negative impact on global warming. I am sure there will be many presentations and conversations highlighting the critical state of our colourful and beautiful environment during AIC 2019.

The AIC clearly illustrates what can be achieved by mutual co-operation and understanding. The Society is in harmony in terms of geography, ethnicity, academic discipline and language. A truly global community.

This year draws to the end my formal commitment to the AIC and its Executive Committee. A journey which started in 2004 at the AIC Interim Meeting in Porto Alegre, Brazil, when I presented the Colour Society of Australia's bid for the AIC 2009 Congress in Sydney to the AIC Executive Committee, at that time chaired by Paula Alessi then President of the AIC.

It has been a truly amazing experience resulting in so many friends in the colour community.

To you all, have a superb colour experience in Buenos Aires, seize the day, have fun and continue to grow your love for the wonderful world of colour.

Best regards

Nick Harkness

Immediate Past President AIC 2019

September 2019

## Color and Landscape: theme of the AIC 2019 Meeting María Paula Giglio



The theme covers different aspects of the landscape, including its visions, constructions, and configurations.

The concept of landscape has a double existence: the observer and what is observed. It can be thought of as having natural and social configurations; a product of actions and interactions of nature and humans; a perception by a social group and individuals.

The landscape has an objective and subjective character; it is a social and cultural construction, a visual reality and a mental image, a transformation from the idea of terrestrial surface to that of identity in a society.

Color and landscape can be . . .

described, written, perceived, drawn, painted, lived, remembered, walked, traveled, thought of, colored, represented, prefigured, created, designed, inhabited, symbolized, transformed . . . from literary, physical, pictorial, cultural, patrimonial, archaeological, anthropological, psychological, historical, philosophical, aesthetic, sociological, geographical, topographic, or epistemological points of view, among others.

The logo of the Meeting uses the colors of jacaranda flowers. The jacaranda is a typical tree of intertropical and subtropical America. It blooms in spring, and in this season makes part of the landscape of Buenos Aires city. Jacaranda flowers, arranged in clusters, have a purplish blue color that remains for a long time in the tree. When they fall, generate a purplish carpet.

María Paula Giglio  
President, Grupo Argentino del Color





## Preface

### José Luis Caivano



The AIC 2019 Conference, organized by the Argentine Color Group (GAC) under the theme “Color and Landscape”, was held in Buenos Aires, Argentina, on October 14-17, 2019, at the Universidad de Belgrano. The GAC had previously organized other two AIC conferences: AIC 1989, the 6th Congress, in Buenos Aires, and AIC 2010, the Interim Meeting “Color and Food”, in Mar del Plata.

For AIC 2019, we received 136 abstracts, from which 134 were accepted by the scientific committee. From them, 102 works were actually presented at the conference: 7 invited plenary lectures (including the Judd and CADE awards lectures), 49 oral papers, and 46 posters. Also, the conference hosted 2 AIC study group meetings (Environmental Color Design, and Color Education), and 2 exhibitions (Color exercises by graphic design students of Dutch art faculties, and The Biosphere Project, see Appendix).

From the posters exhibited, a steering committee set up at the conference selected 3 ones, by assessing content, design, and relevance regarding the conference theme. The authors of these posters were presented with the Hunt Poster Award, provided by the Colour Group, Great Britain (see Appendix).

There were 144 participants, from 27 countries: Argentina, Australia, Austria, Belgium, Brazil, Canada, Chile, China, Colombia, France, Germany, Hungary, Iran, Italy, Japan, Korea, Mexico, Norway, Peru, Portugal, Russia, Spain, Sweden, Switzerland, Taiwan, UK, USA. The percent of participation by country was: Argentina 35%, other countries 65%, with the following distribution: Japan 11%, Brazil 7%, UK 6%, China 5%, Germany 4%, Portugal 4%, Colombia 3%, Italy 3%, USA 3%, remaining countries 19%.

The conference was preceded by the AIC executive committee meeting, a tour by Belgrano neighborhood and the Larreta Museum, and a welcome reception. After the conference sessions, the AIC assembly and the closing ceremony, a banquet and show was offered with tango music and dance at the Piazzolla Tango theater. The next day, a group of participants enjoyed the optional tour to Tigre, the delta of the Parana river.

This publication collects 102 papers of the plenary lectures, oral and poster presentations, covering topics in various fields of color research, in relation to landscape: arts, design, architecture, urban studies, linguistic and cultural studies, lighting, psychology, vision, psychophysics, and technology. Having chaired the scientific committee of the conference, and being able to compile and edit these papers, constitutes a pleasure and a great source of inspiration for me, due to the originality and diversity of approaches offered by the authors.

José Luis Caivano  
Chairman of the Scientific Committee  
Editor of the Proceedings



Conference group photograph, at the entrance of Universidad de Belgrano.

updated: 10 october 2019



**AIC 2019, Color and Landscape - Midterm Meeting of the International Color Association**  
 Buenos Aires, Argentina, 14-17 October 2019 - Organized by the Argentine Color Group  
**Program outline**

venue: Universidad de Belgrano, Zabala 1837, Buenos Aires  
 Auditoriums: Sarmiento, Roca, Urquiza. The hours indicated refer to the beginning of each activity.



Monday, October 14	Tuesday, October 15 (Univ. Belgrano)	Wednesday, October 16 (Univ. Belgrano)	Thursday, October 17 (Univ. Belgrano)	Friday, Oct. 18
	09:00 registration	09:00 plenary lecture (40') (Sarmiento) Zena O'Connor	09:00 plenary lecture (40') (Roca) Verena M. Schindler	
	09:30 opening ceremony (30') (Sarmiento)	09:40 Light & color (Sarmiento) Jost, Cauwerts Minami et al. Xia et al.	09:40 Urban (Roca) Exhibit. (floor 0) Schumacher J. Garavaglia: Color exercises by Kenny, Girelli Caramelo et al. Dutch students	10:00 optional tour:
	10:00 plenary lecture (40') (Sarmiento) Robert Hirschler	10:40 coffee break + posters (40')	10:40 coffee break + posters (40')	full day excursion to Tigre (delta of the Parana river) with lunch included
	10:40 coffee break + posters (40')	11:20 Art & design (Roca) Booker, Angelo Cordero et al. Walker Jofré discussion	11:20 Art & design (Roca) Pinho Souza Echagüe Rodrigues da Silva Arrarte De Lucas Tron	
11:00 to 15:00 AIC executive committee meeting brunch and internal matters	11:20 Art & design (Roca) Booker, Angelo Cordero et al. Walker Jofré discussion	11:20 Art & design (Roca) Pinho Souza Echagüe Rodrigues da Silva Arrarte De Lucas Tron	11:20 Urban (Urquiza) Suárez, Zoppi Noury Musso López et al. discussion	
	13:00 lunch (80')	13:00 lunch (80')	13:00 lunch (80')	
	14:20 posters (40')	14:20 posters (40')	14:20 posters (40')	
15:00 to 15:30 coffee break	15:00 Ambiences (Roca) Alpaerts, Michiels Duarte, Pereira Gou, Wang Wang, Gou Hilmi Or	15:00 Education (Roca) Mally Rossi et al. Kooroshnia Le Duff Lee et al.	15:00 Environment (Urq) Schindler et al. Naoumova, Dias Rodriguez Rezende, Ferreira discussion	
15:30 to 17:30 AIC executive committee meeting reports: study groups future meetings Int. Color Day, etc.	15:00 Psychol. (Urquiza) Lin, Westland Gao, Yan Baniani Liu et al. Kitaguchi et al.	16:40 coffee break + posters (40')	16:00 Judd award (Roca): ceremony & citation (20') lecture: Hirohisa Yaguchi (40')	
15:30 to 18:00 Belgrano walking tour	16:40 coffee break + posters (40')	16:40 coffee break + posters (40')	16:00 CADE award (Roca): ceremony & citation (20') lecture: Roy Osborne (40')	
	17:20 Color & culture (Roca) Jung, Griber Chazarreta Griber et al.	17:20 Vision & psychophysics (Roca) Akiba et al. Yamauchi et al. Shrestha	17:00 coffee break + posters (20')	
	18:20 plenary lecture (40') (Roca) Paula Csillag & A. Lupinacci	18:20 plenary lecture (40') (Roca) Ming Ronnier Luo	17:20 AIC general assembly (Roca) (60')	
18:00 to 21:30 registration welcome cocktail	19:00 Envir. Color Design-SG meeting (Roca) (60')	19:00 Color Education-SG meeting (Roca) (60')	18:20 poster awards closing ceremony (Roca) (60')	
			20:00 banquet & show: Piazzolla tango	

2 award lectures (40') - 5 plenary lectures (40') - 49 oral papers (20') - 2 study group meetings - posters exhibited all 3 days (9 poster sessions, floor 0)

Program outline of the Conference.

# Plenary Lectures



## Plenary Speakers

**Robert Hirschler**

Hungary

color consultant, chair of the AIC Study Group on Color Education, founder of the SENAI/CETIQT Applied Colorimetry Lab in Brazil



**Paula Csillag**

Brazil

professor at the Design Dept. of ESPM College. Since 2015, she is president of the Brazilian Color Association, ProCor



**Zena O'Connor**

Australia

colour consultant, founder of Design Research Associates & the Colour Collective Sydney; formerly, research associate at University of Sydney



**Ming Ronnier Luo**

United Kingdom

professor of Zhejiang University (China), National Taiwan University and Leeds University (UK), AIC Judd awardee 2017



**Verena M. Schindler**

Switzerland

art and architectural historian, chair of the AIC Study Group on Environmental Color Design, former work at Atelier Cler in Paris



Judd award lecture

**Hirohisa Yaguchi**

Japan

professor emeritus of Chiba University, CIE awardee 2009, past-president of CIE-Japan, organizer of AIC 1997 and AIC 2015



CADE award lecture

**Roy Osborne**

United Kingdom

artist, author and educator, former chairman and Turner medal awardee of the Colour Group of Great Britain



# Colour theory and neo-impressionist landscapes

**Robert Hirschler**

Colour consultant, Hungary  
robert@hirschler.hu

*M. Z. peut lire des traités d'optique pendant l'éternité,  
il ne fera jamais la Grande-Jatte.  
(Fénéon 1886)*

## ABSTRACT

This paper aims to give an overview of neo-impressionist landscape painting, explaining how it is different from that of the “romantic impressionists”. Two aspects of nineteenth-century colour theory: optical mixing and simultaneous contrast are discussed as the most relevant to pointillist/divisionist technique. The palette of prismatic colours is briefly presented, and characteristics of impressionist and neo-impressionist facture compared. The Arcadian landscapes of the movement are presented with special reference to *Luxe, calme et volupté* by Matisse.

**Keywords:** *neo-impressionism, pointillism, divisionism, optical mixing, facture*

## INTRODUCTION

Neo-impressionism has been called the “most scientific of all schools of color in art” (Birren 1979) —we shall see below why. It all started with George Seurat who, while attending the École des Beaux-Arts, “discovered the library and devoured scientific works dealing with phenomena of optics” (Rich 1935: 7). His encounter with impressionism, as late as 1882, and his reading of the theories of Charles Henry and, through him, Chevreul, led him to develop a unique style whose best known and most cited example is the *Grande Jatte* (Figure 1).

The preliminaries of neo-impressionism can be traced back two years before the *Grande Jatte* was exhibited in 1886. Seurat started to work on the painting in 1884 and made over 70 drawings and sketches and three larger-scale studies (in oil painting) before finishing his *Grande Jatte*, on which, originally, he didn't apply the technique that it later became famous for. Between 1884 and 1886, while Seurat was working on it, he met Paul Signac, who apparently gave him the final impetus to start applying the colour theory of Chevreul and Rood to painting. The *Bathers*, Seurat's first large

scale landscape (1884) had no traces yet of the new technique, but on subsequent seascapes, painted in 1885 in Grandcamp he began to experiment with pointillism and the divided touch, and “in this respect pointillism had its aesthetic roots in marine painting” (Zimmermann 1991: 205).



Figure 1: George Seurat, *Sunday afternoon on the island of La Grande Jatte*, 1884-1886. The Art Institute of Chicago (Helen Birch Bartlett Memorial Collection).

The general public, by then accustomed to and accepting impressionist paintings, was shocked once again when the Grande Jatte was exhibited. Seurat’s painting —an immense landscape of over  $2 \times 3$  m, populated by some fifty figures— created, once again, a general hue and cry and at first there were very few who understood the significance of this new way of painting.

The novelty was in the way paint was applied to the canvas. In contrast to the impressionists’ spontaneous and loose handling of the brush, here literally every dot and dash was carefully thought out before executed. Neo-impressionism, pointillism and divisionism are words often used interchangeably, but also erroneously. According to Block (2014), *neo-impressionism* is a term “applied to an avant-garde, European art movement that flourished from 1886 to 1906.” The term *divisionism* was “invented by Paul Signac to describe the neo-impressionist separation of colour into dots or patches applied directly to the canvas” (Tosini 2003). It may or may not apply the technique of using tiny dots, which is a characteristic of *pointillism*.

The basic idea behind the divisionist technique was the expectation that if, instead of mixing pigments on the palette (resulting in subdued, dull colours) the dots or dashes of divided “pure” colours applied directly on the canvas would optically mix in the eye of the observer giving the sensation of light, bright colours. We shall see later the limitations of this theory, derived from the writings of Chevreul and Rood, the primary sources of neo-impressionist colour theory.

The pointillist/divisionist technique lends itself particularly well to landscape painting as a genre, and in its variegated forms including townscapes and seascapes, sometimes populated, sometimes not, it was by far the most popular among neo-impressionist painters. It is telling that at the first modern exhibition of neo-impressionism (Herbert 1968) out of a total of 175 paintings there were only six still lifes and fifteen figure paintings shown, the vast majority were landscapes, views of

country and city. Even the contemporary critics, who harshly attacked Seurat's pointillist figure paintings such as *The models*, had kind words for his landscapes and seascapes.

Last year, in addition to *The Grande Jatte*, M. Seurat exhibited a number of truly beautiful seascapes, quiet seas under calm skies; these light, blond canvases suffused with powdery film of light reveal a very personal yet very accurate approach to nature... Strange indeed! This landscape painter, whose seascapes can induce an unending flow of reveries, becomes superficial and unimaginative when he introduces human figures; and it is at this point that the technique he employs—the trill of little dots, the mesh of tiny stiches, the mosaics of colored inlays—ensnares him... (Huysmans 1887)

In spite of the limitations and the harsh criticism, Seurat continued to work in this manner (and created masterpieces) and was followed by Paul Signac and a group of French and other European painters. There was one man, the art critic, playboy and anarchist Félix Fénéon (1887), who immediately understood, explained and, when needed, defended the new movement. He explained the basic difference in the landscape painting of the impressionists and their successors:

The spectacle of the sky, of water, of greenery varies from instant to instant, according to the original impressionists. To seize one of these fugitive appearances on the canvas was their goal. Thus the necessity arose of capturing a landscape in a single sitting, and a propensity for making nature grimace to prove that the moment was indeed unique and would never be seen again.

To synthesize the landscape in a definitive aspect which perpetuates the sensation [it produces]-this is what the neo-impressionists try to do. (Furthermore, their manner of working is not suited to hastiness and requires painting in the studio).

After Seurat's sudden passing away very young (he was barely thirty-two in 1891) Signac continued to carry the torch and became the leader and chief ideologist of the neo-impressionist movement. From his writings, particularly his essay *D'Eugène Delacroix au néo-impressionisme* (1899) we know the thoughts behind neo-impressionist painting and much of what it really means.

## COLOUR THEORY IN THE 19th CENTURY

In order for us to discuss scientific considerations (if any) behind neo-impressionist painting, we have to understand some basic concepts and how much of this information was available to end-of-nineteenth-century French painters. By the beginning of the nineteenth century, Newton's doctrine was widely accepted, although Goethe did his very best in his *Farbenlehre* to discredit the English scientist. Revolutionary new thoughts were published by Young on trichromatic colour vision, but these took quite some time to be accepted -if at all. Brewster, one of the leading authorities on optics, simply disregarded Young and contradicted Newton.

In the middle of the nineteenth century, two scientists made profound effect on the formation of colour theory relevant to arts: Chevreul (1839) with his law of simultaneous contrast; and Helmholtz (1867) who explained the difference between additive and subtractive mixing. Seurat and the other neo-impressionist painters learned about these theories first probably through Charles Blanc (1867) and through the French translation of Ogden Rood's *Modern chromatics* (1879, 1881).

### Additive, partitive and subtractive mixing

Let's see first the modern explanation of the three kinds of mixtures: additive, partitive and subtractive. These methods may have been known to the neo-impressionist painters, but not necessarily with the correct explanations.

According to the CIE (2019), *the additive mixture of colour stimuli* is the stimulation that combines on the retina the actions of various colour stimuli in such a manner that they cannot be perceived individually. It can be the result of combining differently coloured lights either on a screen (from where the mixture is transmitted or reflected) or directly on the retina (in which case it is often called *optical mixing*). Combining red, green and blue/blue-violet lights to achieve a wide range of colours was first suggested by Young (1807: 440) providing the first explanation of trichromatic vision:

From three simple sensations, with their combinations, we obtain seven primitive distinctions of colours; but the different proportions, in which they may be combined, afford a variety of tints beyond all calculation. The three simple sensations being red, green, and violet, the three binary combinations are yellow, consisting of red and green; crimson, of red and violet; and blue, of green and violet; and the seventh in order is white light, composed by all the three united.

The first practical application of this theory was Maxwell's demonstration of the first colour photograph (Evans 1961) based on the projection and superposition of three coloured images. Three black and white photographs were taken of a tartan ribbon: one through a red, another through a green and a third one through a blue filter; and these colour separation images were projected through red, green and blue filters respectively and recombined on the screen. The resulting coloured image was the first photograph based on RGB projections demonstrating additive colour mixing. This process returned over a hundred years later in the form of projection television as shown in Figure 2. In *additive mixing* (projection of light beams) the component lights are combined before they reach the observer's eye. The tristimulus values of the mixture are the sum of those of the components, and this means that the lightness values also add up. The chromaticity of the mixture is the weighted average of the component chromaticities.



Figure 2: Additive colour mixing by the superposition of three coloured beams (RGB).  
Photo © Robert Hirschler 1977.



*Partitive (or additive-averaging) mixing* occurs “in the eye” (therefore it is often called *optical mixing*) when two or more stimuli reaching the retina are either too small or too rapidly alternating for the eye to resolve them as separate stimuli and are perceived as one. The first case is our everyday experience with monitors, whose image is composed of a multitude of RGB phosphors and coloured textile fibres mixed before spinning (Figure 3, left), the latter is the well-known spinning disc (Maxwell disc or Newton’s disc; Figure 3, right).

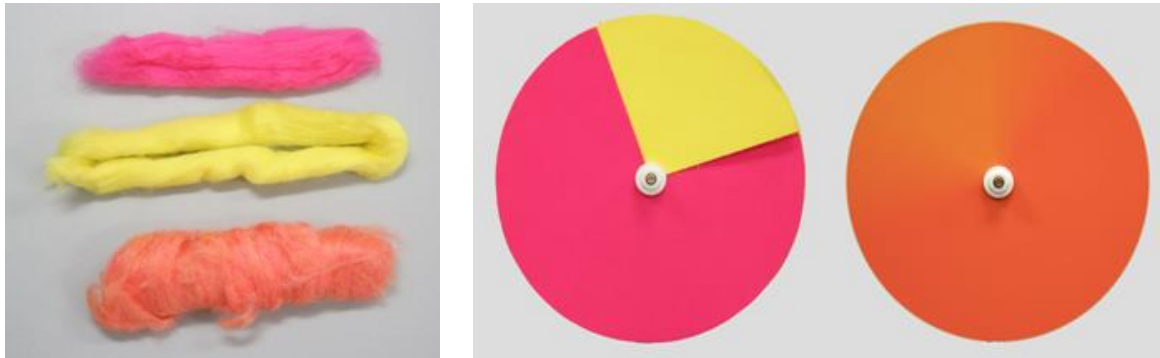

Figure 3: Partitive colour mixing by mixing coloured fibres (left) and by spinning a disc with two coloured sections (right). Photos © Robert Hirschler 2001.

When mixing coloured fibres, the resulting colour is somewhat lighter and less saturated than the result of mixing very similar colours on a spinning disc, due to the surface reflection of the fibres “diluting” (adding white to) the colour resulting from the selective absorption by the dyed fibres. The colour of the spinning disk optical mixture is always the area-weighted average of the two (or more) segments, which means that the claims (going back to Newton) that with a good selection of “spectral” colours the spinning disc will appear white are simply unfounded: even with the best selection of colours the disc will appear grey.

According to popular belief neo-impressionist painters (the “pointillists”) painted with so tiny dots placed next to each other that the result was complete fusion of these in the eye, resulting in optical mixing. This belief was started with the artists themselves but also with some of the first friendly critiques of these paintings, trying to explain in a scientific manner why those paintings appeared as they did, and also explaining that from an adequate viewing distance those dots would indeed melt into bright, vivid, uniform colours. Four years after the exhibition of the *Grande Jatte*, Albert Aurier (1890), the art critic already accepted the new technique with all of its shortcomings:

The first efforts in neo-impressionism, interesting but still clumsy... I declare that, for my part, I did smile ironically more than once in those days before a painting made out of a mosaic of separate patches, incapable of being fused, which called to mind the motley colors of Harlequin’s jacket. But little by little, Monsieur Pissarro mastered the new technique he had adopted, this pointillist procedure.

However, not all the critics received these strange paintings positively, and some of the problems came from not understanding that the desired effect —optical fusion with higher brilliance— was

strongly dependent on the viewing distance. Homer (1964: 171-175) discusses the importance of viewing distance in finding the paintings as luminous as claimed by —among others— Signac and Fénéon, Those who viewed the paintings from too close could see the individual points (no fusion) and those who viewed them from too far lost the lustre and could see the desaturated mixture of complementary colours.

*Subtractive mixing* is the process of taking away a part of the composite (often white) light, most often by selective absorption. This is the case of most object colours, where light hits the surface of a coloured object which absorbs light of certain wavelengths and transmits or reflects the rest. When paints or pigments are mixed, only that portion of the light is transmitted or reflected which is not absorbed by any of the components. It must be emphasized here that this is not “colour mixing” but *colourant mixing*. The resulting colour is inevitably darker than that of any of the components, and the main motivation of the neo-impressionist painters in applying dots or dashes of pure colour on the canvas (and not mixing the paint on the palette) was to avoid this dreaded dulling and darkening.

This difference between light mixtures and pigment mixtures was not obvious until Helmholtz (1852) described it. He compared disc mixtures (partitive) with pigment mixtures using the same pigments (chrome-yellow and ultramarine) and found that on the disc he obtained pure grey while the mixture of pigments appeared green, and the pigment mixture was much darker than the grey. Rood (1879: 149) measured the amount of black and white needed to be added to the disc (optical) mixtures to match the respective pigment mixtures. He found, that depending on the pigment composition four to fifty-two per cent of black was needed to achieve a match. This calculation appeared in the writings of Fénéon, justifying the neo-impressionists’ method of putting pure paints side by side directly on the canvas instead of mixing them on the palette, achieving thereby higher luminosity and lustre.

Even though modern colour theory has explained all the reasons and technical intricacies of additive and subtractive mixing, misconceptions still abound in the literature. Even the eminent art historian, expert in impressionism and particularly Seurat, Robert L. Herbert (1968: 18), made misleading statements, such as “Even violet paint by itself, being solid matter, reflects portions of other colors than its own, although we allow ourselves to be dominated by the one hue. These other colours when mixed with the similar ‘other colors’ of the greenish yellow, combine to form the dull result.” It would take a separate study to discuss in detail all the problems within this brief statement, but suffice it to say that, properly speaking, violet is not “one hue” because we always see both red and blue in it, but much more importantly mixing violet light with “other colors” will make it brighter, mixing a violet *paint* with a greenish yellow *paint* is what will make it duller. Not because violet rays (i.e., the combination of all the light rays evoking the sensations of violet) combined with greenish yellow rays would make it duller, but because the greenish yellow paint will absorb a good part of the violet rays.

### **Simultaneous contrast**

Colour contrast is the relationship between the colour of a stimulus and that of its immediate surround. The phenomenon has been known since antiquity, but the first systematic study is that of Chevreul (1839) whose book was available to and studied by the neo-impressionist painters. He defined simultaneous contrast as follows:

If we look simultaneously upon two stripes of different tones of the same colour, or upon two stripes of the same tone of different colours placed, side by side, if the stripes are not too wide, the eye perceives certain modifications which in the first place influence the intensity of colour, and in the second, the optical composition of the two juxtaposed colours respectively. Now as these modifications make the stripes appear different from what they really are, I give to them the name of simultaneous contrast of colours ; and I call contrast of tone the modification in intensity of colour, and contrast of colour that which affects the optical composition of each juxtaposed colour. (Chevreul 1860: 7)

Simultaneous contrast is but one manifestation of contrast effects, depending on the relative areas, the perceived object/background relationship and a number of other factors the perceived sensations of the relation of the two (or more) colours may be very different. Figure 4 illustrates the well-known Munker-White illusion. For a detailed explanation see White (2010).

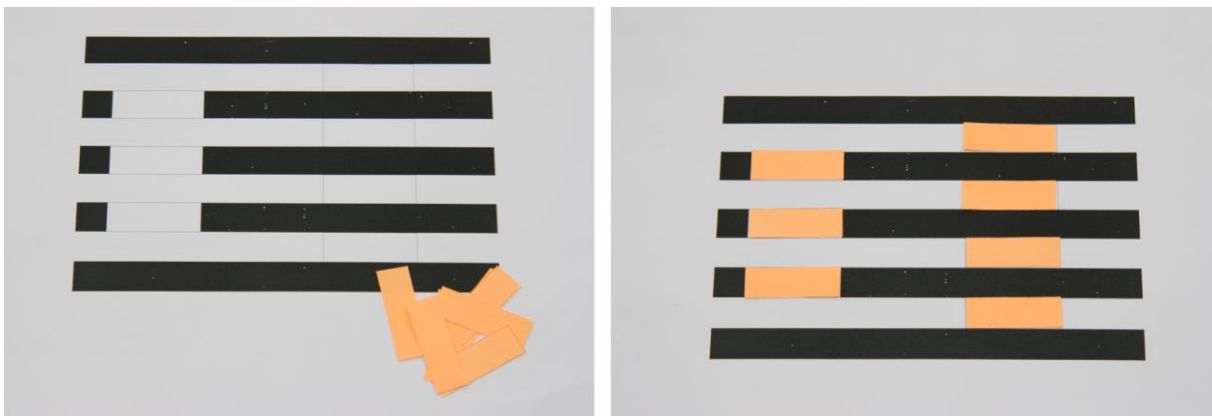

Figure 4: Illustration of the Munker-White effect with paper chips cut from the same sheet. The effect is the opposite to the one expected by the laws of simultaneous contrast: the chips over the light background appear to be lighter than those over the dark background. Photos © Robert Hirschler 2001.

### THE NEO-IMPRESSIONIST PALETTE

Ives (1934), in his Thomas Young Oration, bemoans the fact that painters use too many pigments in their palettes, generally 12 to 20, Ingress even used 27, whereas in theory three primary colours (lights) or even pigments would be sufficient to create most of the colours needed on the canvas. He correctly points out that the three primary pigment colours cannot be red, yellow and blue, but rather minus red, minus green and minus blue —what we today would call yellow, magenta and cyan.

Signac (1899: 266-267) compared the palettes of Delacroix, the impressionists and the neo-impressionists. Delacroix's palette was composed of both pure and mixed colours and, in the creation of mixed colours, he was mixing paints on the palette but also made avail of optical mixing. The impressionists' palette was composed "solely of pure colours approximating those of the solar spectrum". They were also mixing paint on the palette and used optical mixing as well. The neo-impressionists used the same palette as that of the impressionists but used (according to Signac) only optical mixing. Three typical palettes are shown in Figure 5.



Figure 5: The palette of Delacroix (left), Monet (middle) and Seurat (right).

Photos ©: Matthias Schaller / VG Bild/Kunst, 2019.

Seurat used a very different palette until 1884-1885 which included earth colours. Having met Signac, however, he changed to a palette very similar to that of the younger artist, consisting only of prismatic colours and white, in three rows. In the top row eleven pure pigments straight from the tube, in the second row the same pigments mixed with white and in the third row white. For the first stage of painting the *Grande Jatte* (1884-1885) he used the following pigments: vermilion, organic red lake, burnt sienna, iron oxide, chrome yellow, viridian, emerald green, ultramarine blue, cobalt blue, lead white, black charcoal or bone. Then, for the second stage of modifying and retouching his masterpiece (1885-1886), he dropped the burnt sienna, iron oxide and the black, but included zinc yellow (Fielder 1989). The neo-impressionist painters often mixed paints of similar colours on the palette. For instance, for his 1886 painting *Honfleur, un soir, embouchure de la Seine* Seurat used about 25 different tones mixed on the palette (Herbert 1968: 115).

### COLOUR AND FACTURE IN NEO-IMPRESSIONIST LANDSCAPES

Signac (1899: 207) summarised the main benefits of the new neo-impressionist technique in four points:

1. The optical mixture of uniquely pure pigments (all hues of the prism and all their tones);
2. The separation of the diverse elements (local color, color of lighting, their reactions, etc.);
3. The balance and proportion of these elements (in accordance with the laws of contrast, gradation, and irradiation);
4. The choice of a brushstroke which fits the size of the painting.

According to Gustave Kahn, the symbolist poet and art critic (quoted by Smith 2014: 56), “Armed with a new procedure ... [the neo-impressionist painters] have aimed to render not how the landscape looked at some particular moment but the silhouette it has for the whole day.” This was very different from the impressionists’ trying to catch the fleeting moments in the open air. Most of the neo-impressionist painters made several studies (very often sketches in the open air) to mount their paintings with painstaking care in the studio.

This fundamental difference in their painting method was, at the same time, the cause and the effect of the differences between the impressionist and the neo-impressionist facture. Signac (1899: 263) explains that “The hatchings of Delacroix, the comma-strokes of Monet, and the neo-impressionists’ *divided touches* are artificial tools which these painters use to express their particular vision of nature.” Figure 6 compares the comma-strokes of Monet (left) the dots of Seurat (middle) and the divided touch of Signac (right).



Figure 6: Details.

Left: Monet (1882) *Cliff walk at Pourville*; The Art Institute of Chicago.

Middle: Seurat (1884-1886) *Sunday afternoon on the island of La Grande Jatte*; The Art Institute of Chicago.

Right: Signac (1898) *Entrée du port de Marseille*; Kröller-Müller Museum; Photo: Robert Hirschler (2019).

Signac (1899: 207) himself is categorical: “...dotting has nothing in common with the aesthetic of the painters defended in these pages, or with the technique of division used by them. The neo-impressionist does not paint with dots, he divides.” This, however, was not quite so consequently executed in the facture of these painters. Even within one painting, the dots can give way to short strokes, and most of the neo-impressionist painters often changed their touch from one painting to another. Ratliff (1992) explains in great detail the consequences of using small dots (or strokes, the form is not important, the size is) versus larger dashes: depending on the viewing distance the picture elements (what in today’s digital language would be called *pixels*) may or may not be seen separately. In the first case we have optical mixing, in the second it is simultaneous contrast.

Théo van Rysselberghe, who was one of the prominent co-founders of the Belgian artistic circle Les XX, embraced the neo-impressionist doctrine in 1886, having seen Seurat’s *La Grande Jatte*. He soon started painting in the new style, and it is interesting to note how his facture changed over the years. If we compare three seascapes painted in 1889, 1899 and 1905, respectively, we can see his hand moving from dots to regular dashes to irregular brushstrokes, as illustrated in Figure 7.



Figure 7: Details of paintings by Théo van Rysselberghe; Kröller-Müller Museum. Photo: Robert Hirschler (2019)  
Left: *Le 'Per-Kiridy' à marée haute* (1889); middle: *Boulogne-sur-Mer* (1899); right: *Coup de vent d'est* (1905).

Experimenting with the size of the dots and the size and shape of the dashes is something we can observe in the case of most neo-impressionist painters, including Seurat himself. He was perfecting his command of the dots (culminating in his late figure paintings), but by 1890 he let himself be seduced by larger spots of the divided touch, for instance in his *Moored boats and trees* (Philadelphia Museum of Art) and his last Gravelines seascapes.

Of course, size alone does not determine whether the colours will be optically mixed or presenting simultaneous contrast; viewing distance is of equal importance. According to Ratliff (1992: 52), in museums neither Leonardo's "twice the diagonal" nor Pissarro's "three times the diagonal" viewing distance (for neo-impressionist paintings) rules are observed. "The size of the gallery, the press of the crowd, the whim of the spectator, the lighting of the work, and many other factors all serve to determine the distance at which the painting is seen." Signac (1899: 215) quotes Delacroix:

Moreover, everything depends on the distance, the touch blends itself into the whole composition, but it gives the painting an accent which could not be produced by mixing the colors together.

There is an optimum distance, where simultaneous contrast turns into optical mixture, and at this point the painting assumes a shimmering quality. There is a general expectation for the optical mixing to be complete, and observers are often disappointed that it does not happen. However, as Herbert (1968: 19) explains, "it is *toward* this optical mixture that the eye struggles. In so doing, an active vibration takes place in which the separate colors are seen in a stimulating shimmer."

### ARCADIA IN NEO-IMPRESSIONIST LANDSCAPES

Arcadian landscapes of Camille Corot and particularly those of Pierre Puvis de Chavannes were very much known and appreciated in nineteenth century France, and neo-impressionist painters were no doubt influenced by these works. Signac and Cross moved to the south of France in the 1880s and both had their go at Arcadia. Cross painted *The evening air* in 1893-1894 and Signac laboured away on his monumental *In the time of harmony – The golden age is not in the past, it is in the future* for two years (1893-1895). The ownership of this huge 310 × 410 cm canvas is still the subject of a quarrel between Signac's heirs and the town hall of Montreuil, where it currently may be seen.

When Théo van Rysselberghe visited Cross and Signac in 1895 he was immediately captivated by Cross's *L'air du soir* hanging in Signac's dining room (to be joined later by Matisse's *Luxe, calme et volupté*). It took Rysselberghe two years to finish his version of the Arcadian landscape (*L'heure embrasée*), owing as much to the *Doux pays* by Puvis de Chavanne as to Cross's influence. Henri Matisse, during his short flirt with the divisionist technique (in 1904-1905) asked the advice and help of Signac and Cross. It was probably the latter's influence, who was at that time very much in favour of the populated landscape as a genre, that Matisse started to work on his most important painting in the neo-impressionist style: *Luxe, calme et volupté* (Figure 8.)

The critics were not very kind to Matisse when writing about this painting, first exhibited (together with four of his still lives, a landscape and two interiors) at the 21st Exhibition of the Société des Artistes Indépendants. A certain Am. C. (1905) wrote the following: "Henri Matisse plays the difficult role of 'expected genius' among young people. He shows still lives of a wonderful brilliance, but his decorative canvas [*Luxe, calme et volupté*] is perfectly ugly."

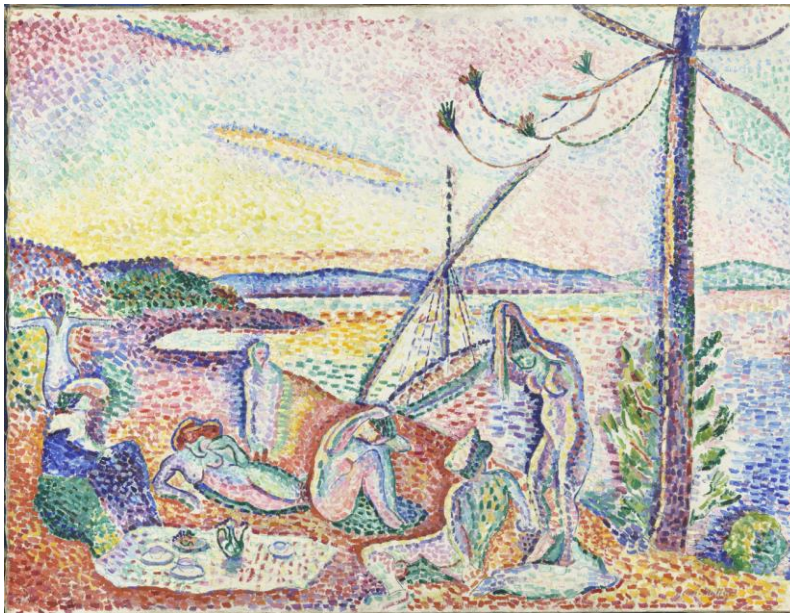

Figure8: Henri Matisse (1904-1905) *Luxe, calme et volupté*. © Succession H. Matisse.  
Localisation: Paris, Musée d'Orsay. Photo © RMN-Grand Palais (Musée d'Orsay) / Hervé Lewandowski.

Matisse himself was also rather dissatisfied with this painting. He had wanted to comply both with his academic upbringing and with the newly learned divisionist technique —not succeeding in either to his satisfaction. He could not forget about contour lines (as shown around the leaning figure in the detail) and his dashes were too separated, with the white of the canvas showing through in between.

In spite of Matisse's dissatisfaction with *Luxe, calme et volupté* it has later become highly esteemed by critics and his painter colleagues alike. According to Elderfield (1976: 54):

Matisse's neo-impressionist paintings were not inhibited in color. Indeed, *Luxe, calme et volupté* uses a full spectrum of pure isolated hues with a boldness without precedent in any finished neo-impressionist oil. Both the wide spacing of the mosaic form and the startling combination of "unnatural" yellows, lavenders, and reds take this work well beyond the confines of literal description.

Kelly (2014: 140) considers it the "culmination of the neo-impressionist treatment of Arcadia", but, at the same time, "the swan song of the movement". It may have been the swan song of neo-impressionism, but it was also the harbinger of a new style: Derain, Dufy and other would-be Fauves joined the new movement having seen Matisse's masterpiece.

## REFERENCES

- Am. C. 1905. Aux indépendants. *Les Temps Nouveaux* 10 (50) (15 to 21 April): 7.
- Aurier, A. 1890. Camille Pissarro. *La Revue Indépendante*, March: 508. Quoted in Smith (2014: 60).
- Birren, F. 1979. Neo-impressionism: The most scientific of all schools of color in art. *Color Research and Application* 4 (4): 200-207.
- Blanc, Ch. 1867. *Grammaire des arts du dessin*. Paris: J. Renouard.
- Block, J. 2014. Neo-impressionism. *Oxford Art Online - Grove Art Online*. Updated and revised, 28 July 2014, <https://doi.org/10.1093/gao/9781884446054.article.T061684>.
- Chevreul, M. 1839. *De la loi du contraste simultané des couleurs*. Paris: Pitoit-Levrault.
- . 1860. *The principles of harmony and contrast for colours and their applications to the arts*, 3rd ed., translated by Ch. Martel. London: Henry G. Bohn.
- CIE (Commission Internationale de l'Éclairage). 2019. E-ILV. <http://eilv.cie.co.at/term/24>. Accessed on 29/7/2019.
- Elderfield, J. 1976. *The "wild beasts": fauvism and its affinities*. New York: The Museum of Modern Art.
- Evans, R. M. 1961. Maxwell's color photograph. *Scientific American* 205 (5): 118-128.
- Fénéon, F. 1886. L'Impressionnisme aux Tuileries. *L'Art Moderne* 6 (19 September): 300-302.
- . 1887. Le néo-impressionnisme. *L'Art Moderne* 7 (1): 139. Translation by L. Nochlin, *Impressionism and post-impressionism, 1874-1904*. Englewood Cliffs, NJ: Prentice Hall, 1966: 111-112.
- Fielder, I. 1989. A technical evaluation of the Grande Jatte. *Art Institute of Chicago Museum Studies* 14 (2), The Grande Jatte at 100: 173-179, 244-245.
- Helmholtz, H. 1852. On the theory of compound colours. *Philosophical Magazine* 4 (28): 519-534.
- . 1867. *Handbuch der physiologischen Optik*. Leipzig: Leopold Voss.
- Herbert, R. L. 1968. *Neo-impressionism*. New York: The Solomon R. Guggenheim Foundation.
- Homburg, C. 2014. *Neo-impressionism and the dream of realities*. New Haven: Yale University Press.
- Homer, W. I. 1964. *Seurat and the science of painting*. Cambridge, MA: The MIT Press.
- Huysmans, J. K. 1887. Chronique d'art. Les indépendants. *La Revue Indépendante*, April: 53-54. Quoted in Rewald (1990: 170)
- Ives, H. E. 1934. Thomas Young and the simplification of the artist's palette. *Proceedings of the Physical Society* 46 (1): 16-34.
- Kelly, S. 2014. Neo-impressionist Arcadia. In Homburg (2014: 121-141).
- Ratliff, F. 1992. *Paul Signac and color in neo-impressionism*. New York: The Rockefeller University Press.
- Rewald, J. 1990. *Seurat: a biography*. New York: Harry N. Abrams.
- Rich, D. C. 1935. *Seurat and the evolution of "La Grande Jatte"*. Chicago: The University of Chicago Press.
- Rood, O. N. 1879. *Modern chromatics*. New York: D. Appleton and Company.
- . 1881. *Théorie scientifique des couleurs*, translation of Rood (1879). Paris: Baillière.
- Signac, P. 1899. *D'Eugene Delacroix au néo-impressionnisme*. Paris: La Revue Blanche. Translated from the 3rd French edition (1921) by W. Silverman. Translation in Ratliff (1992: 195-285).
- Smith, P. 2014. The neo-impressionist painter. Color, facture and fiction. In Homburg (2014: 47-71).
- Tosini, A. 2003. Divisionism. *Oxford Art Online - Grove Art Online*. <https://doi.org/10.1093/gao/9781884446054.article.T022975>.
- White, M. 2010. The early history of the White illusion. *Colour: Design and Creativity* 5 (7): 1-7.
- Young, T. 1807. *A course of lectures on natural philosophy and the mechanical arts*. London: Joseph Johnson.
- Zimmermann, M. F. 1991. *Seurat and the art theory of his time*. Antwerp: Fonds Mercator.



# Landscapes used in design and art: the work of Fred Jordan, the Brazilian master of color

Paula Csillag\*, Ana Lucia Lupinacci

ESPM College, Sao Paulo, Brazil

\* pcsillag@espm.br

## ABSTRACT

The aim of this paper is to present an academic research that was done at the Design Undergraduate Course at ESPM College, São Paulo, Brazil, about a designer and artist, Fred Jordan. Jordan's work is today part of the Brazilian cultural heritage and relevant for the comprehension of the visual history in Brazil. Particularly, the focus here is related to the use of imaginary landscape in his work. All of Jordan's work is extremely chromatic and much appreciated and used as reference by other Brazilian designers. The empirical part of this research covered a historical critical evaluation of Jordan's works, conducted at his former home place. This empirical research lasted for one year and also involved semi-structured interviews with members of the family. Results presented include an analysis of the way Jordan used chromaticity in his work.

**Keywords:** *design, art, imaginary landscape, German thinkers, nineteenth century*

## INTRODUCTION AND BIOGRAPHY

The objective of this article is to present the results of an academic research, carried out by the Graduation Course in Design ESPM SP. This research was generated from Fred Jordan's family contact with ESPM SP. The family considered ESPM as the best institution for this research, entrusting to it, all the analysis of his work and visits to the private residence of the family. The family strongly emphasized why ESPM would be a good institution for this trust: a school with design and advertising courses, having a history at MASP. Throughout his life were present significant names also present in the history of ESPM.

The work of Fred Jordan today is part of the visual production developed in Brazil, therefore a constituent of graphic memory and an important legacy for Brazilian graphic design. This work, therefore, contributes to the understanding of the history of design and culture in the country (Bastos 2012).

Fred Jordan arrives in São Paulo at the age of nine in 1936, with his family of Jewish origin, coming from Berlin, as a result of the Nazi horrors beginning in Germany. Jordan began his studies at the School

of Fine Arts of São Paulo between 1944 and 1945, but left the pure arts for something that interested him more, the application of visual communication to the creation of advertising. Thus, between 1945 and 1950, Jordan works in advertising agencies Prado, Lintas and McCann Erickson.

In 1949, Jordan began his professional relationship with the Nicollini Print Shop in the graphic department studio of Kurt Epstein. Epstein was a graphic designer trained in Germany and, at the time that Jordan worked there, artistic director of Nicollini Print Shop (Gráfica Nicollini). In 1959 Jordan becomes art director and later he works as general technical director of Gráfica Nicollini. Epstein's tutoring created a rich and unique repertoire for Jordan, which was added to his self-discipline, inquiring attitude, tenacity and aesthetic sensibility. As Olaf Leu quoted in *Novum Gebrauschgraphik*, "Jordan's careful initial steps may explain the perfection of later work, the unmistakable treatment of color, space, and typography" (Leu 1983).

Jordan married in the late 1950s, with Sonja, his childhood love in Berlin and uninterrupted correspondent in these years of Jordan in Brazil. Sonja and Fred had a son, André. In the early 1960s, Jordan oversaw the construction of his studio-house in Granja Viana, in Cotia, near São Paulo. This construction was surrounded by lush vegetation of the Atlantic forest, which, according to the family, was important to Jordan, who considered this exuberance to be characteristic of Brazilian culture.

From 1979, already as artistic director of Gráfica Nicollini, Jordan becomes a consultant and no longer an employee there. The atelier becomes his office. Jordan died in São Paulo in 2001 and, although he did not become naturalized, he liked being a Brazilian designer and wanted to be remembered as such.

## THE RESEARCH

The empirical, historical-critical research conducted by the ESPM SP Design Course lasted one year and the object of study was the visual communicator Fred Jordan. The first phase of the research was of conversations with the family, carried out in his residence, visiting his house-studio, in Cotia, near São Paulo.

There were five visits to the studio-house in which were conducted: classification of the work, photographic record, survey of manuscripts, magazines and articles authored by Jordan or about him. A semi-structured interview was also conducted, as well as informal conversations accompanied by observation and annotations, characterizing a qualitative approach, with triangulation and data articulation.

The analysis of written material revealed Jordan's correspondence with people like Antonio Candido, Carlos Drummond de Andrade, Olaf Leu, Vilem Flusser, also reflections that the artist put on paper about art, artists, some theories (such as color in Goethe) and the relation of visual art to music. Jordan, a connoisseur of classical music, was also a music critic and has some publications in the area. The team that carried out the research had the participation of students from the Graduate Course in Design of ESPM SP, whom accounted having had a very inspiring experience with such a rich work.

The results of this research were presented in a round table discussion, with the participation of design professionals and journalists. An exhibition was also held with the title of "Memory and Research - Fred Jordan's Design", open to the public and the production of a video. The invitation can be seen in Figure 1. The exhibition was supported by the Association of Graphic Designers - Brazil. The opening featured a presentation by designer Alexandre Wollner (Bastos 2012).



Figure 1: Invitation for the event “Memória e Pesquisa – O Design de Fred Jordan” held at ESPM SP.

## WORK AND LEGACY

In 1952, Jordan had the opportunity to make the first calendar for Gráfica Nicollini, thought of as a promotional gift that would be sent to customers later that year. Prior to Jordan’s presence at Nicollini, designers chose an image for the calendars they believed to be the tastes of their audience, for example, a chrome of a girl running with a dog. The artistic director at the time, Epstein, had already developed some illustrations for the calendars, but claimed lack of time to create more and his biggest concern was with the quality of graphic production. Seeing the girl’s chosen chrome, Jordan commented that this image did not represent Nicollini, and that it could represent any company; that it did not correspond to the reality of the time, lacked personality, and Jordan believed that it was necessary to reproduce in this promotional gift, some illustration that also presented the work and graphic excellence of the company (Bastos 2012).

Thus, Epstein delegated to Jordan this task, for which he developed a thematic project, which was renewed for decades, until 1999, date of the last edition. In all 47 calendars; many of them would become dysfunctional after the current year, but with the possibility of being seen as poster, since the dates could be perforated, remaining a vigorous image there.

The articulation with Goethe’s theory of colors and artists of the first half of the nineteenth century in Germany marked the uniqueness of his language, that was also seen in his calendars. Jordan produced a leaflet explaining Goethe’s prismatic experiments in detail, and showing how to reproduce them with simple materials (Figure 2).

This articulation with Goethe’s chromatic studies was well known in the series of calendars called Color Project (Figure 3), from the 1980s. According to artists like Maria Bonomi, Jordan’s calendars were anxiously waited, to be placed in the rooms of the people who received them, seeing them as imaginary landscapes for the health of the soul.

Notably, through his calendars, the designer wanted to understand the articulation and balance between man, landscape, nature, universe, history; he also intended to bring to his audience, the inquiry into their role in these relations, as can be seen in Figures 4 and 5. In calendars, Jordan suggests different ways to represent the infinite and the time/space continuum, presenting texts and experiments that explain physical phenomena (Bastos 2012).

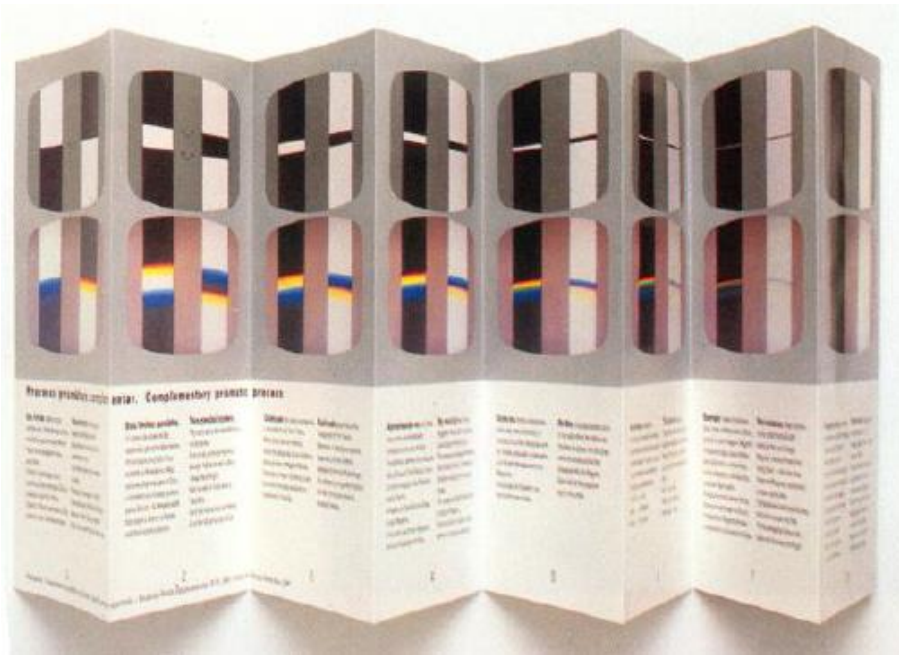

Figure 2: Leaflet produced by Jordan, distributed with the magazine *Estudos Avançados*, vol. 7, no. 19, 1993, about Goethe's prismatic experiments.



Figure 3: Color Project, for Nicollini Calendars, 1987: Color 3, Blues; Color 4, Yellows and Oranges; Color 5, Greens; Color 6, The Violets; Color 7, Magentas and Reds; Color 8, Prismatic Mobius.

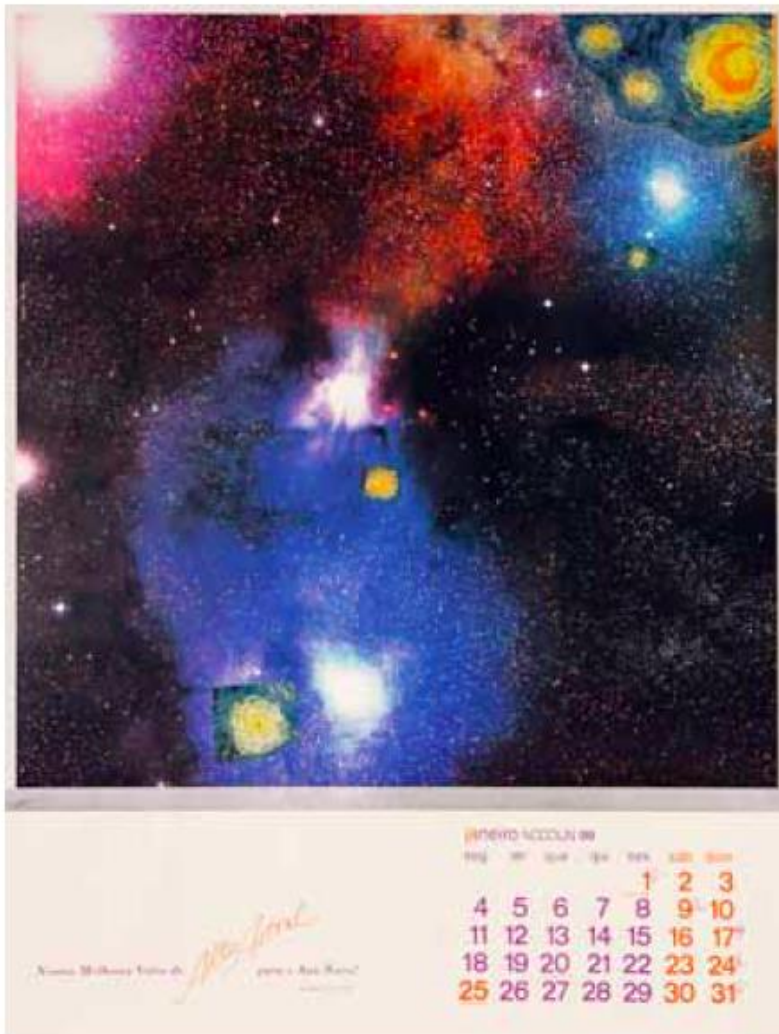

Figure 4: Calendar for Gráfica Niccollini: Starry Night, 1998.

In this calendar (Figure 4), he brings the text: “Suddenly, who would imagine? The most mysterious landscapes of the Universe seem to be more reachable than the depths of the Unconscious.” The calendar shows a picture made by satellite with an infrared telescope. On the back, Jordan shows the message: “Important: Keep the Calendars near to Human warmth.”

Jordan brings in this calendar (Figure 5) the text: “Trying to represent Time and Space, artists and scientists create [...] landscapes and images that make the eyes say Yes and the mind say No.”

His advertising work was strong; he participated in several campaigns, and a relevant example, is of the Goethe Institute of languages. The posters in Figure 6 were the starting point for the development of the whole language of the advertising campaign. Jordan has humor, likes to play with words, images, concepts, representations. He uses parody, citations, associated with the improved technique. In these posters for the Goethe Institute’s campaign, the visual unit and the particular color treatment of each of the characters are present, together with an informal treatment.

Jordan worked with calendars, predominantly, and is recognized for that, but also developed packaging, logos and visual identity, graphic advertising, always allied to experimental, non-utilitarian projects that nurture each other. In particular, there are a number of collages made with packaging chips, which clearly demonstrate this dialogue. Most of his works are accompanied by texts, deepening ideas and thoughts, complementing the representation and the graphic language, illustrated in Figures 7 and 8.



Figure 5: Calendar for Gráfica Nicollini: Incompatible Space, 1975.



Figure 6: Posters for Goethe Institute, with informal phrases, like, “Marlene wants to have a chat with you”, referring to Marlene Dietrich.

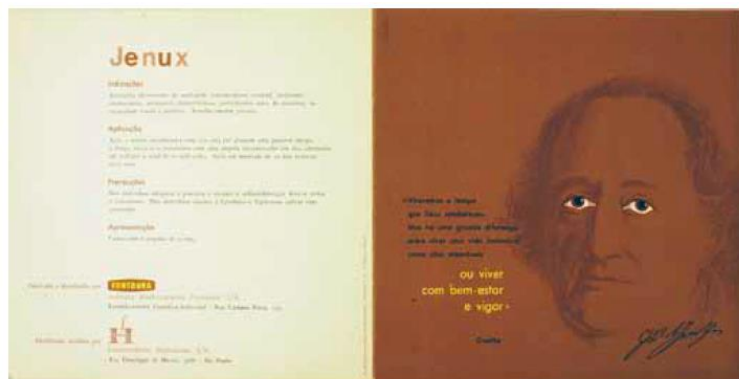

Figures 7 and 8: Package for Jenux Novocaína medicine.

In Figure 7, the cover of a medicine package, features a Goethe drawing and its reproduced signature. Jordan presents inside the package (Figure 8) a text by Goethe: “There is a great difference between living the pitiful life as miserable dogs or living with well-being and vigor.”

Although he had contact and some closeness to concrete artists and visual communicators, Jordan did not participate in movements or manifestoes in this sense. In the 1950s, the preponderant visual language in Sao Paulo was remarkably concrete, in an attempt to adapt to the quest for industrial modernization. Jordan, contrary to most of the visual communicators of his generation, did not stop using elements of the artistic language, allied to elements of the graphic language, as can be seen in Figures 9 and 10. For example, he used gestures along with typography, or, highly figurative manual illustrations composing with geometrized graphic cutouts. Although not conceptually approaching the concrete designers, Jordan lived and was close to them, especially Alexandre Wollner. Jordan makes the following statement in the 1980s, quoted by Wollner: “Maybe I have a style, but I do not care. What matters to me is to do the thing that is effectively the most appropriate to the problem at hand” (Leu 1983).

Poster and calendar, traditional graphic pieces of European culture, were thought and perceived by Jordan also as objects of experimentation. Search for new languages and the best technologies, which again brings us back to contemporary visual culture. Some pieces of Jordan require user interaction in the form of cutting, folding, and gluing operations, as shown in Figures 11 and 12.

The text that accompanies this calendar in Figures 10 and 11, brings explanations on how to fit the strips, and says: “It comes with cartridge with colored strips that can be embedded in the illustration to be assembled according to the taste of each person. Important: Keep the remaining 12 strips in the package so that you can change anytime the rhythm of a good year of 1978.”



Figure 9: Packages for Gráfica Nicollini.



Figure 10: Package for Gráfica Nicollini: Pen-ve-oral – Penicilina medicine.



Figures 11 and 12: Calendar for Gráfica Nicollini and Details: Ritmos, 1977.



## FINAL CONSIDERATIONS

Jordan was quoted in many foreign publications, and has also published works in several specialized journals. Innovation and daring graphics, brought him the award for permanent collection of MoMA, Museum of Modern Art, New York, after exhibiting his calendars.

In 1978 Jordan received recognition in the exhibition Jordan Graphic, in MASP Museum in São Paulo, under the curatorship of Pietro Maria Bardi. Jordan found clients ready to dare, giving him the opportunity to present his particular vision, allowing him to be the anchor of facts (Lupinacci 2007, 2010).

Jordan, with his European repertoire, his tenacity and high aesthetic sensibility, made contributions, articulating relationships between man, landscape, nature, universe, history, meaning of life, time, art and artists. From studies of natural phenomena referenced in his calendars, Jordan exploited, through his illustrations the meaning of relationships amongst people in society. For him, nature's balance depended on the connections observed in many aspects in the world, on the evolution of the Universe, on the History of Humankind. Jordan worked with a lot of lyricism and he revealed his poetic subjectivity in his work. He presented an immersion in his own world, full of emotion and subjective feelings. To him, time was a crucial element which transformed his calendars—seemingly useful artifacts—into insights about the world and the permanence of mankind. It is intended here to make known the work of Fred Jordan, who has greatly influenced the cultural chromatic heritage of design in Brazil.

## REFERENCES

- Bastos, H. R. 2012. *O design de Fred Jordan*. São Paulo: Faculdade de Arquitetura e Urbanismo, Universidade de São Paulo, doctoral thesis.
- Leu, O. 1983. *Novum Gebrauschgraphik*.
- Lupinacci, A. L. 2007. História e contemporaneidade: O design de Fred Jordan. In: *Congresso Internacional de Pesquisa e Desenvolvimento em Design 4, Anais eletrônicos*. Rio de Janeiro.
- . 2010. História e contemporaneidade: O design de Fred Jordan. In: *Côrte-Real*, Eduardo, ed. IADE Creative University.

# Effective environmental visual literacy: pedestrian crossing design and the key roles of colour and contrast

Zena O'Connor

Design Research Associates, Sydney, Australia  
zena@zenaoconnor.com.au

## ABSTRACT

Evidence-based colour strategies represent an approach to environmental design that aims to improve the interface between the built environment and users. In this context, specific colour strategies have the capacity to encourage activation and engagement in urban spaces as well as support orientation and wayfinding initiatives, and the safe operation of daily activities. This paper focuses on the role that colour strategies can play in improving environmental visual literacy. The findings from a two-stage study are reported. This study investigated the effectiveness of a set of colour strategies embedded in pedestrian crossing designs. The designs were evaluated using the Delphi technique and a panel comprised of people with expert colour knowledge provided nominal group consensus in respect to the embedded colour strategies. The next stage of this research will involve implementing designs that scored highly to test their effectiveness *in situ*.

**Keywords:** *environmental visual literacy, evidence-based colour strategies, environmental design, orientation and wayfinding, pedestrian crossing design*

## INTRODUCTION

Colour plays an important role in the built environment beyond aesthetics. Specifically, colour can encourage activation and engagement in architecture and urban spaces, and add a sense of joy and playfulness. In addition, specific colour/contrast strategies can support orientation and wayfinding strategies, plus assist with the safe operation of daily activities by providing clear and unambiguous differentiation of design factors embedded in the built environment.

This paper reports on findings from a two-stage study which investigated the roles of colour and contrast in respect to environmental visual literacy. Specifically, the study's hypothesis focused on the effectiveness of specific colour and contrast strategies in respect to interventions aimed at enhancing environmental visual literacy within the context of pedestrian crossing design. The research primarily drew on theories and methodologies from environment-behaviour studies (EBS), research that focuses on human interactions in the built environment. In addition, this study was also

informed by visual perception theories as well as Gestalt principles of perceptual organisation plus theories of colour and colour application, and visual literacy research. The results indicate that high chroma colour and contrast supergraphic design interventions attract attention and stand out, and perhaps represent effective intervention options for pedestrian crossing design.

## THEORETICAL FOUNDATIONS

This paper draws together strands of my previous research across several areas (see O'Connor 2015, 2016, Rourke and O'Connor 2009, 2009a).

**Environment-behaviour studies (EBS)** focus on the interface between the built environment and human response. The general aim of EBS research is to improve this interface for all people irrespective of age and physical, visual and cognitive capacity. EBS research tends to be underpinned by a conceptualization of the environment-behaviour interface developed by Lewin (1967):

$$B = f(P, E).$$

Lewin contends that behaviour (B) is a function of the interaction between personal factors (P) and the environment (E), and contends that personal factors vary depending on individual characteristics, physical strength and weaknesses (Lang 1987, Nasar and Yurdakul 1990).

Findings from EBS research have informed review of design factors as well as the development of Universal Design principles and user-centred design guidelines, including the ways in which colour and contrast enhance the environmental interface (Nasar 1994).

**Theories of visual perception and Gestalt principles of perceptual organisation** suggest that colour and especially light-dark contrast play key roles in environmental perception and evaluation. The retina comprises approximately six million colour-sensitive cone receptors, predominantly located in the fovea area directly in the line of sight. The retina also features about 120 million rod receptors, located mostly in the peripheral area of the retina. Out-numbering cone receptors by about 20-to-1, rod receptors are sensitive to luminance (lightness-darkness levels) but not to different colours per se (Goldstein 1996, Hoffman 1998, Livingstone 2002).

Due to the mechanics of human vision (including saccades and fixational reflex), strong light-dark contrast as well as strong colour contrast (hue contrast plus saturation contrast relative to darker contextual colour) play critical roles in attracting attention and enabling us to differentiate design details, depth and form (Kolb 2003, McPeck et al. 1999, Shang and Bishop 2000).

It is for these reasons, that colour/contrast and light-dark contrast have been noted as the major drivers for perceiving and evaluating contours and figure-ground distinctions as per Gestalt principles of perceptual organisation (Koffka 1935, O'Connor 2015, Wertheimer 1938).

**Theories of colour and colour application** contend that colour has three key attributes: hue, tonal value and saturation (Albers 1963, Gage 2000, Itten 1961, Munsell 1921, Ostwald 1916). Hue is the broad colour category and understanding implied by colour terms such as 'red', 'blue' or 'yellow'. Tonal value (also referred to as 'Value' or 'Tone') refers to the lightness or darkness of a colour. Saturation (also referred to as 'Chroma' or Chromaticity) relates to the level of intensity or purity of colour from full intensity through to desaturated, achromatic colour.

In respect to contrast, Itten identified seven types of contrast: Contrast of hue; Light-dark contrast; warm-cool contrast; complementary contrast; simultaneous contrast; contrast of saturation; and contrast of extension (Itten 1961).

Strong colour/contrast (that is, contrast of hue in conjunction with light-dark contrast and contrast of saturation) provides an effective catalyst for design differentiation in visual imagery and the built environment (O'Connor 2013).<sup>1</sup>

**Environmental visual literacy** is an extrapolation of visual literacy, “a group of vision-competencies a human being can develop...which enable visually literate persons to discriminate and interpret the visual elements, objects, symbols, natural and man-made” (Debes 1969: 27).

Environmental visual literacy sits at the interface between human response and the built environment, and relies on functional visual perception, memory and cognitive processing of explicitly noticeable and unambiguous design factors. It is defined as the way in which users ‘read’ environmental design cues and make sense of these in a meaningful way for orientation, wayfinding and the safe operation of daily activities (O'Connor 2016, 2018, 2018a).

## THE ROLES OF COLOUR AND CONTRAST IN THE BUILT ENVIRONMENT

Research and anecdotal evidence suggest that colour and contrast can achieve the following:

- Activate and enliven the built environment and urban precincts.
- Encourage engagement and add a sense of joy, happiness and playfulness.
- Support and improve orientation and wayfinding strategies.
- Assist with the safe operation of daily activities by drawing attention to key design details.
- Small to large scale supergraphics can contribute to a sense of place and urban uniqueness.

Colour enlivens urban precincts and encourages engagement, primarily due to correlation between environmental colour and positive affective response. A recent study that investigated four Instagram hashtags (#happycity, #urbanhappiness #cityhappy, #cityofhappiness) found that colour in urban spaces is the fourth most consistent factor (after open space, natural elements and historic or heritage buildings), irrespective of demographics or geographic location (Pringle and Guaralda 2018).

In addition, colour/contrast strategies can be used to differentiate spaces, nodes and pathways, and ensure that environmental design features are easily and quickly perceived and understood.

Various projects around the world provide examples of the ways in which colour/contrast strategies help to achieve these aims. Large dots painted onto the roadbed of Shortland Street, Auckland, is an initiative of the Auckland Design Office aimed at traffic calming and pedestrian safety. A similar intervention exists at the Lincoln Street intersection in Chicago. Illuminated crosswalks have been installed in The Netherlands; while pedestrian crossings designed by Carlos Cruz-Diez have been installed in San Isidro, Lima to enhance urban precincts. Similarly, Bankside Broadwalk is an initiative in Lavington Street, Southwark, London, aimed at helping pedestrians safely navigate roadworks and building sites. The projects in Auckland, Lima and London are featured in Figure 1.

---

<sup>1</sup> For the purposes of this research, the term ‘colour/contrast’ is used to refer to colours that contrast in hue, tonal value and saturation. In this context, strong colour/contrast is further defined as 50%+ differential in hue and light-dark contrast relative to contextual colour.



Figure 1: Colour/contrast supergraphic intervention designs in New Zealand, Lima and England.

### RESEARCH METHODOLOGY

Qualitative research methodologies common to environment-behaviour studies were used to evaluate the effectiveness of a set of six environmental intervention designs. These designs featured different colour/contrast variations and were inspired by existing initiatives around the world, as per Figure 1. Three types of designs were included for evaluation: white photoluminescent (Resene FX Nightlight glow-in-the-dark paint) stripes; white stripes plus coloured stripes and white stripes plus large coloured dots. Simple white stripes were also included as a control design (Figure 2).

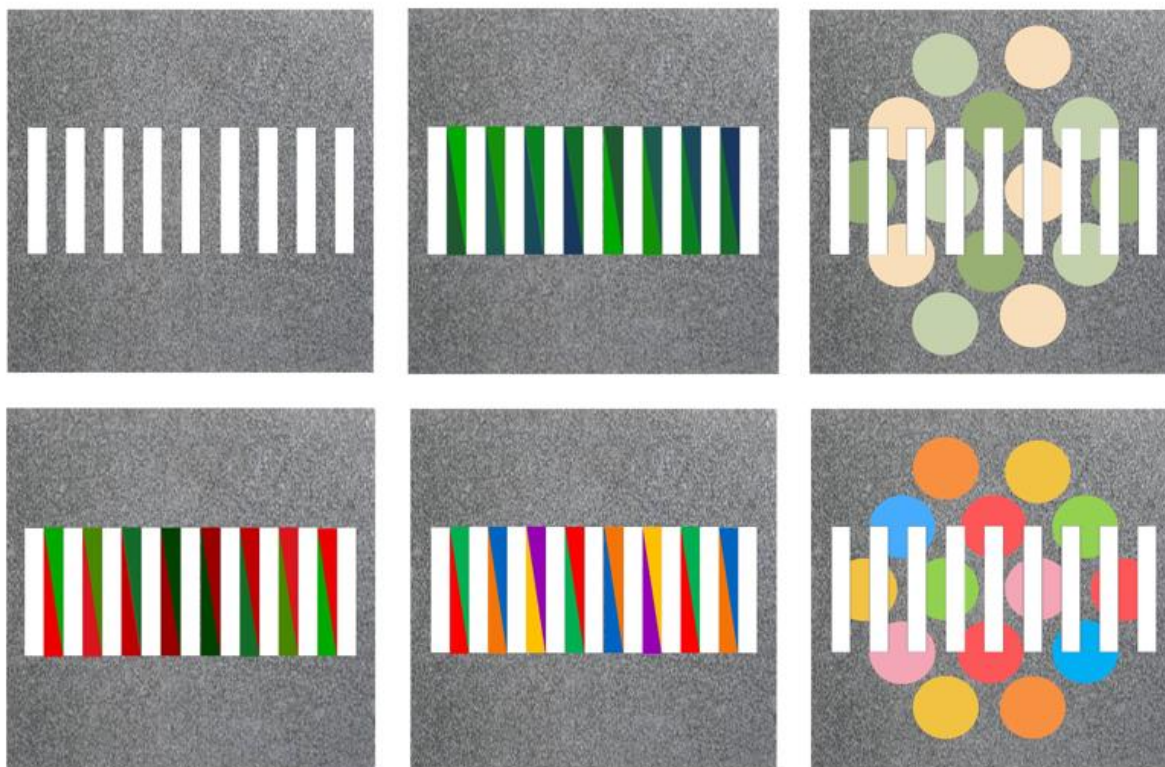

Figure 2: Six intervention designs featured in this research.

The designs featured specific variations of colour and contrast elements, linked to the roles that colour and contrast play in human visual perception and in particular, perceiving and cognitively identifying environmental design factors. Specifically, the designs featured high chroma analogous colours (green and blue); high chroma contrasting colours (red and green); high chroma contrasting colours (red and green, orange and blue, purple and yellow); mid chroma dots (muted green and beige); high chroma dots (red, green, blue, orange, yellow and pink). Each of these coloured variations featured photoluminescent rather than non-photoluminescent white stripes (Figure 2).

The Delphi technique was used to evaluate the effectiveness of intervention designs. The evaluations occurred at the annual conference of the Colour Society of Australia (Melbourne, 9 September 2018) and AIC-2018, the Interim Meeting of the AIC, International Colour Association (Lisbon, 26 September 2018). In line with Delphi technique protocols, these two groups were deemed to have relevant knowledge and experience specific to the aims of this research study.

The participant group size totaled 98 (Melbourne 44, Lisbon 54) and represented a relatively even mix of males and females, predominantly over 30 years of age.

Participants were not advised of the purpose of the research survey. The intervention designs were presented in pairs in an apparently random manner and participants were asked to identify which design of the pair attracted more attention and was deemed to be more conspicuous (“which design attracts more attention and stands out more”).

## RESULTS AND DISCUSSION

The results are summarized and presented in Figure 3, and indicate a relatively high level of similarity of responses across the two participant groups: Lisbon and Melbourne.

Nominal group consensus indicates that six high chroma contrasting colour dots attracted more attention and were relatively more conspicuous: 97.8% (Melbourne) and 87% (Lisbon) participants. Photoluminescent white stripes were considered to attract more attention and stand out more (94.6% Melbourne and 84.9% Lisbon); and six high chroma contrasting colours were deemed to attract more attention and stand out more by 84.8% (Melbourne) and 96.3% (Lisbon) participants.

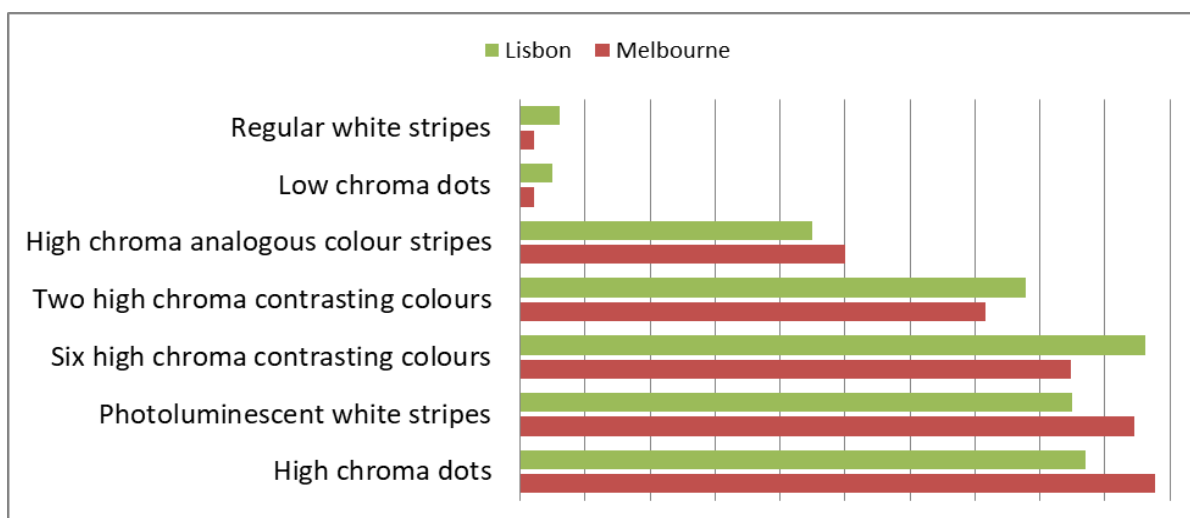

Figure 3: Aggregated survey results: Lisbon and Melbourne.

These results also indicate weaker results for regular white stripes, low chroma dots and high chroma analogous colour stripes. This reinforces the effectiveness of high chroma colours as well as the use of contrasting colours evident in the intervention designs.

## CONCLUSION AND FURTHER RESEARCH

Urban interventions that feature colour and supergraphics have the capacity to activate urban spaces, encourage engagement, and add a sense of joy, happiness and playfulness.

In addition, specific colour/contrast strategies have the capacity to contribute to orientation and wayfinding strategies, and support the safe operation of daily activities by ensuring that embedded environmental design features are designed in such a way that they attract attention, are easily and quickly perceived.

The results reported herein suggest that high chroma contrasting colours combined with supergraphics and photoluminescent white stripes may be more conspicuous as pedestrian crossing designs than regular white stripes. The findings from this research provide a basis to recommend changes to existing pedestrian crossing designs and use colour/contrast as an intervention device. This recommendation is also underpinned by knowledge that colour contrast and luminance contrast declines in the human visual perception system from middle ages onwards (Fiorentini et al. 1996, Livingstone 2002, Werner et al. 1990). In urban spaces, marginally stronger colour/contrast strategies may therefore be more effective.

The next stage of this research involves implementing pedestrian crossing designs that feature high chroma contrasting colour depicted in supergraphic dots and photoluminescent white stripes, and conducting on-site research to determine effectiveness in real settings. Another option for future research is to transfer this colour/contrast approach to interior spaces in aged care and healthcare facilities, and evaluate effectiveness in these contexts.

## ACKNOWLEDGEMENTS

Thanks are due to delegates at the Annual Conference of the Colour Society of Australia, Melbourne (2018) and delegates at the Interim Meeting of the International Colour Association, Lisbon (2018) who agreed to participate in the study as nominated experts in colour theory and application.

## REFERENCES

- Albers, J. 1963. *Interaction of color*. New Haven, CT: Yale University Press.
- Debes, J. 1969. Visual literacy: an overview. *Audiovisual Instruction* 14 (8): 25-27.
- Fiorentini, A., M. Porciatti, M. C. Morrone, and D. C. Burr. 1996. Visual ageing: Unspecific decline of the responses to luminance and colour. *Vision Research* 36 (21): 3557-3566.
- Gage, J. 2000. *Colour and meaning: art, science and symbolism*. London: Thames & Hudson.
- Goldstein, E. B. 1996. *Sensation and perception*. Pacific Grove, CA: Brooks, Cole.
- Hoffman, D. D. 1998. *Visual intelligence: How we create what we see*. New York: W.W. Norton & Company.
- Itten, J. 1961. *The art of color: the subjective experience and objective rationale of color*, revised ed. New York: John Wiley & Sons, 1973.

- Koffka, K. 1935. *Principles of Gestalt psychology*. London: Routledge & Kegan Paul.
- Kolb, H. 2003. How the retina works. *American Scientist* 91 (1): 28-35.
- Lang, J. 1987. *Creating architectural theory: The role of the behavioral sciences in environmental design*. New York: Van Nostrand Reinhold.
- Lewin, K. 1967. *Field theory in social science: Selected theoretical papers*. London: Social Science Paperbacks.
- Livingstone, M. 2002. *Vision and art: The biology of seeing*. New York: Abrams.
- McPeck, R. M., V. Maljkovic, and K. Nakayama. 1999. Saccades require focal attention and are facilitated by a short-term memory system. *Vision Research* 39 (8): 1555-1566.
- Munsell, A. H. 1921. *A grammar of color*. Accessed online on 20 October 2017 from <http://www.gretamacbeth.com/Source/Solutions/munsell/index.asp>.
- Nasar, J. L. 1994. Urban design aesthetics: The evaluative qualities of building exteriors. *Environment Behavior* 26: 377-401.
- Nasar, J. L., and A. R. Yurdakul. 1990. Patterns of behavior in urban spaces. *Journal of Architectural and Planning Research* 7 (1): 71-85.
- O'Connor, Z. 2013. Colour as catalyst: Using colour differentiation to enhance learning. In: *Building minds, forging bridges: Teaching in a visually littered world*, A. Rourke and V. Rees, eds. Champaign, IL: Common Ground Publishing.
- . 2015. Colour, contrast and Gestalt theories of perception: The impact in visual communications design. *Color Research and Application* 40 (1): 85-92.
- . 2016. Colour/contrast strategies to improve environmental visual literacy. In: Universal Design Symposium, Auckland, 26 October 2016.
- . 2018. Colour/contrast interventions to improve environmental visual literacy. In: Annual Conference of the Colour Society of Australia, Melbourne, 8-9 September 2018.
- . 2018a. Environmental visual literacy: Examining the roles of colour and contrast. In: *Proceedings of the International Colour Association (AIC) Conference 2018*, Lisbon, 25-29 September 2018, M. Gamito and M. J. Durão, eds. Newtown, NSW: International Colour Association, 151-156.
- Ostwald, W. 1916. *Die Farbenfibel (The colour primer)*. Cited in Gage (2000).
- Pringle, S., and M. Guaralda. 2018. Images of urban happiness: A pilot study in the self-representation of happiness in urban spaces. *The International Journal of the Image* 8 (4): 97-122.
- Rourke, A. J., and Z. O'Connor. 2009. Look before you leap: Testing some assumptions on visual literacy and predominant learning modalities of undergraduate design students in Australia and New Zealand. *International Journal of Learning* 16 (8): 33-45.
- . 2009a. Investigating visual literacy levels and predominant learning modality among undergraduate design students in Australia: Preliminary findings. *Design Principles and Practices: An International Journal* 3 (2): 17-28.
- Shang H., and I. D. Bishop. 2000. Visual thresholds for detection, recognition and visual impact in landscape settings. *Journal of Environmental Psychology* 20 (4): 125-140.
- Werner, J. S., D. H. Peterzell, and A. J. Scheetz. 1990. Light, vision, and ageing. *Optometry and Vision Science* 67 (3): 214-229.
- Wertheimer, M. 1938. Laws of organisation in perceptual forms. In: *A source book of Gestalt psychology*, W. Ellis, ed. London: Routledge & Kegan Paul.



# A summary of the parametric studies on colour difference evaluation

**Ming Ronnier Luo**

State Key Laboratory of Modern Optical Instrumentation, Zhejiang University, Hangzhou, China  
School of Design, University of Leeds, UK  
m.r.luo@leeds.ac.uk

## ABSTRACT

The paper provides an overview of the research works on the impact of viewing parameters on colour difference evaluation. The parameters included scaling method (perceptibility vs. acceptability), materials (textile, coating), contents (patches vs. images), physical size, separation, colour difference magnitude, background colour, illuminant. For each parameter, the visual effect was revealed. For those most significant effects such as background, colour difference magnitudes, separation, they can be modelled to become a parametric colour difference formula.

**Keywords:** *colour difference formula, parametric effect*

## INTRODUCTION

Colour difference research has been extensively investigated over the years. Luo (2002) gave a comprehensive review on a number of colour-difference formulae such as CIELAB (CIE 2018), CMC (Clarke et al. 1984), BFD (Luo and Rigg 1987, 1987a), CIE94 (CIE 1995) and CIEDE2000 (CIE 2001, Luo et al. 2001). The latter was developed to fit 4 datasets having medium colour difference magnitude ( $\Delta E^*_{ab} < 5$ ), and the formula was proposed by CIE (2001). It is now widely used across all industries. However, all the formulae mentioned above can only be applied under a set of reference viewing conditions as defined by CIE (1995), i.e. a pair of samples should be object colours, large sample size ( $> 4^\circ$  field of view) with edge contact, medium colour difference magnitudes viewed under a D65 simulator at high luminance level (1000 lux), against a mid-grey background ( $L^* = 50$ ). In reality, this set of viewing conditions is difficult to achieve. Various studies have been carried out to study the impact of different viewing parameters with intention to develop a parametric colour difference equation to consider different viewing conditions.

The typical research to study parametric colour difference effect includes the following procedures:

**Step 1:** to prepare some test stimuli. For example, five CIE colour centres introduced by Robertson (1978) were extensively studied by many researchers.

**Step 2:** to perform visual assessment under experimental phases including different viewing parameter in question, say different coloured backgrounds, separations.

**Step 3:** to reveal the visual effect by comparing visual results between different phases. One method frequently used was to fit the data of each centre in terms of an ellipse or ellipsoid equation as defined in Equation 1. By comparing two ellipses, the discrepancy between two viewing parameters can be found.

$$\Delta E^2 = k_1 \Delta a^{*2} + k_2 \Delta a^* \Delta b^* + k_3 \Delta b^{*2} + k_4 \Delta a^* \Delta L^* + k_5 \Delta b^* \Delta L^* + k_6 \Delta L^{*2} \quad (1)$$

where  $\Delta L^*$ ,  $\Delta a^*$ ,  $\Delta b^*$  are the differences of  $L^*$ ,  $a^*$ ,  $b^*$  between two samples in a pair in CIELAB space.

**Step 4:** to find the parametric factor(s) in a colour difference equation as given in Equation 2 or Equation 3 to be used in a particular viewing conditions.

$$\Delta E' = \frac{\Delta E}{k_E} \quad (2)$$

$$\Delta E = \left( \sqrt{\left( \frac{\Delta L}{k_L s_L} \right)^2 + \left( \frac{\Delta C}{k_C s_C} \right)^2 + \left( \frac{\Delta H}{k_H s_H} \right)^2} \right)^\gamma \quad (3)$$

where  $k_E$ ,  $k_L$ ,  $k_C$  and  $k_H$  are the parametric factors to take into account the parametric effects. The  $s_L$ ,  $s_C$  and  $s_H$  are the weighting functions for lightness, chroma and hue differences respectively. Note that Equation 3 can also be used for CIEDE2000 formula. Although it was originally published as a 4-terms ellipsoid equation including an additional rotation term, it also has a 3-terms version (ISO/CIE, 2014) which should be used in Equation 3. The  $\gamma$  factor in Equation 3 was proposed by Huang et al. (2015). They found that by introducing a single  $\gamma$  factor for a particular formula, the performance of all the formulae tested were improved for colour differences of all magnitudes.

## PARAMETRIC EFFECTS

This section summarizes some obvious parametric effects from the author and his colleagues' earlier studies.

### Background effect

#### *Lightness crisping effect*

Ho et al. (2002) investigated the background effect using the neutral surface and display colours respectively. 21 and 24 equal lightness differences were assessed under different neutral backgrounds from  $L^*$  of 0.2, 20, 50, 70 and 95 for the display colours and  $L^*$  of 20, 50 and 90 for the surface colours. Clear lightness 'crisping effect' was revealed, i.e. the visual difference is the largest for the lightness

of the samples close to that of background. The  $s_L$  function of CIEDE2000 (see Equation 3) was modified as Equation 4 to give satisfactory prediction to consider the lightness crispening effect.

$$s_L = (0.015 (\bar{L} - L_g))^2 / \sqrt{20 + (\bar{L} - L_g)^2} \quad (4)$$

where  $\bar{L}$  and  $L_g$  are the mean lightness values for the mean of two samples in a pair and the background, respectively. The  $L_g$  was 50 for CIEDE2000, because most of the visual results used to develop the equation was against a neutral background having an  $L^*$  of 50. Xin et al. (2004) did an independent study using display colours. 38 neutral differences were assessed against 5 neutral backgrounds from dark to bright. The lightness crispening effect was again clearly discerned.

### *Chromatic crispening effect*

The colour background effect was extensively investigated by Cui et al. (2001, 2001a) on a CRT display. They carried out an experiment to study various parametric effects including 7 coloured backgrounds (white, black, grey, red, yellow, green and blue) and each at 3 separations (0, 1 and 2 pixels). The results showed a small parametric effect by about 14%. The largest effect was found to compare colour difference between same colours having a black frame and no frame (37%). There is clear 'chromatic crispening effect' was found, i.e. a smaller chromatic difference between the target and background will have a large perceived difference. This is different from the previous 'lightness crispening effect' mentioned earlier.

### **Scaling methods (perceptibility and acceptability)**

In the following discussion, each equation will be presented including parametric factors, such as CMC (2:1), which means to have  $k_L = 2$  and  $k_C = k_H = 1$ . In real applications, it is frequently set  $k_C = k_H = 1$ .

In the original papers, CMC (1:1) and BFD (1:1) were recommended to apply to the perceptibility data, for which the visual data have a linear relationship with the visual colour difference. CMC (2:1) and BFD (1.5:1) are recommended for the acceptability data, for which observers judged each pair in terms of pass or failed. This implies the lightness difference is less noticeable than the chroma or hue difference for assessing the colour differences using acceptability than perceptibility methods.

### **Texture effect**

#### *Materials*

CMC (2:1), CIE94 (2:1) and BFD (1.5:1) were recommended for the textile industry. Their (1:1) equations were recommended for the paint industry. This seems to indicate that when assessing colour difference for more textured materials, lightness difference is less noticeable than the hue and chroma differences, and vice versa.

#### *Simulated texture*

Huertas et al. (2006) carried out experiment using the display images to simulate different extent of textures including 5 groups (uniform, +/- lightness, +/- chroma and black random dots) and 4 areas (5, 20, 50, 80%). The results showed that neither small differences in dot size (1 or 4 pixels) nor sparse

number of dots (less than 20% of the surface of the sample) changed the tolerances found for homogeneous samples. The results showed that the textures led to statistically significant differences with respect to homogeneous samples. It is not simple to provide a unique set of parametric factors for all the potential textures. However, the simulated textures consistently reduced the perceived colour difference or, mainly (but not only) increase lightness parametric factor (see Equation 3).

### **Physical size effect**

It was found that there is a physical size effect, i.e. a larger size pair will show more colour difference than that of a smaller size, But the effect is small (Cui et al. 2001, 2001a), less than 10% from their results on a CRT.

### **Colour difference magnitude effect**

This effect was extensively studied by Wang et al. (2012), Mirjalili et al. (2019). Wang et al. carried out an experiment including three parts according to the colour-difference magnitudes: large colour difference (LCD), small colour difference (SCD), and threshold colour difference (TCD) corresponding to mean CIELAB  $\Delta E$  values of 50.3, 3.5, and 0.6, respectively. Three data sets were used to test various colour-difference formulae and uniform colour spaces. The results showed that all formulae predicted visual results for the full range of colour differences reasonably well except CIELAB, i.e., it performed the best for the LCD data but not well for TCD and SCD data. Mirjalili et al. (2019) studied the colour difference pairs with no separation and found that the colour difference magnitudes did affect the lightness parametric factor ( $k_L$ ), i.e. lightness difference is less noticeable than chroma or hue difference for larger colour differences than that of smaller differences.

### **Separation effect**

Mirjalili et al. (2019) also developed a new formula for non-separation colour difference pairs by replacing  $k_L$  in Equation 3 by  $D_L$  function for CIEDE2000, for which  $D_L$  equals to  $D_L = 0.08\Delta E_{00} + 0.27$  for less than 9.1. The new equation is designated as the color-difference formula for NS viewing condition, named  $\Delta E_{NS}$ . This indicates that the lightness colour difference becomes less noticeable when colour difference magnitude increases until 9.1. The opposite effect occurs when exceeding 9.1. Comparing the same pairs with separations of different distances, the effect is small (Guan and Luo 1999a, 1999b, 1999c).

### **Image effect**

It was also found that  $k_L$  values to be approximately 1.5 to 2 for assessing images comparing with colour patches (CIE 2011, Liu et al. 2013).

### **Illuminant effect**

Luo and Rigg (1987b) also reported a set of colour difference data under illuminant A. They then developed a formula by fitting this data, named BFDA. It was found that all formulae developed using data from daylight fit the data badly. Their performances can be improved by first transforming all colours under illuminant A to a daylight illuminant say D65 using a chromatic adaptation transform such as CAT02 or CAT16, and then calculate colour difference using these formulae.

## CONCLUSION

In total, 8 different parametric effects were investigated, background, scaling method, texture, physical size, colour difference magnitudes, separation, illuminant. These effects were described in the paper. The more significant parameters are background, texture, colour difference magnitude, . From all these studies, it was found that CIEDE2000 always give a good performance (top 2 rankings). It can be used as the basis for the parametric colour difference equation by including  $k_L$ ,  $D_L$ ,  $S_L$  and  $\gamma$  factors.

## REFERENCES

- CIE (Commission Internationale de l'Éclairage). 1995. Industrial colour-difference evaluation. Vienna: CIE Central Bureau, publ. 116-1995.
- . 2001. Improvement to industrial colour-difference evaluation. Vienna: CIE Central Bureau, publ. 142-2001.
- . 2018. Colorimetry. Vienna: CIE Central Bureau, publ. 15-2018.
- . 2011. Methods for evaluating colour differences in images. Vienna: CIE Central Bureau, publ. 199-2011.
- Clarke, F. J. J., R. McDonald, and B. Rigg. 1984. Modification to the JPC79 colour-difference formula. *Journal of the Society of Dyers and Colourists* 100 (4): 128-132.
- Cui, G. H., M. R. Luo, W. Li, and B. Rigg. 2001. Colour difference evaluation using CRT colours. Part I - Data gathering. *Color Research and Application* 26: 394-402.
- . 2001a. Colour difference evaluation using CRT colours. Part II - Parametric effects. *Color Research and Application* 26: 403-412.
- Guan, S. S., and M. R. Luo. 1999a. Investigation of parametric effects using small colour differences. *Color Research and Application* 24: 331-343.
- . 1999b. A colour difference formula for assessing large colour differences. *Color Research and Application* 24: 344-355.
- . 1999c. Investigation of parametric effects using large colour differences. *Color Research and Application* 24: 356-368.
- Ho, K. M. R., G. Cui, B. Rigg, and M. R. Luo. 2002. A lightness difference formula for predicating crispening effects. In: *Proceedings of the 10th Color Imaging Conference: Color Science and Engineering Systems, Technologies, Applications*. Scottsdale, AZ, 161-165.
- Huang, M., G. Cui, M. Melgosa, S. Manuel, C. J. Li, M. R. Luo, and H. Liu. 2015. Power functions improving the performance of color-difference formulas. *Optical Express* 23: 597-610.
- Huertas, R., M. Melgosa, and E. Hita. 2006. Influence of random-dot textures on perception of suprathreshold color differences. *Journal of the Optical Society of America* 23 (9): 2067-2076.
- ISO/CIE (International Organization for Standardization / Commission Internationale de l'Éclairage). 2014. Colorimetry - Part 6: CIEDE2000 colour-difference formula. Vienna: CIE Central Bureau, publ. 11664-6:2014.
- Liu, H., M. Huang, G. Cui, M. R. Luo, and M. Melgosa. 2013. Color-difference evaluation of digital images using a categorical judgement method. *Journal of the Optical Society of America A* 30: 616-626.
- Luo, M. R. 2002. Development of colour-difference formulae. *Review of Progress in Coloration and Related Topics* 32: 28-39.

- Luo, M. R., and B. Rigg. 1987. *BFD(l:c)* colour-difference formula, Part I - Development of the formula. *Journal of the Society of Dyers and Colourists* 103: 86-94.
- . 1987a. *BFD(l:c)* colour-difference formula, Part II - Performance of the formula. *Journal of the Society of Dyers and Colourists* 103: 126-132.
- . 1987b. A colour-difference formula for surface colours under illuminant A. *Journal of the Society of Dyers and Colourists* 103: 161-167.
- Luo, M. R., G. Cui, and B. Rigg. 2001. The development of the CIE 2000 colour difference formula. *Color Research and Application* 26: 340-350.
- Mirjalili, F., M. R. Luo, G. Cui, and J. Morovic. 2019. Color-difference formula for evaluating color pairs with no separation: DENS. *Journal of the Optical Society of America A* 36 (5): 789-799.
- Robertson, A. R. 1978. CIE Guidelines for coordinated research on colour difference evaluation. *Color Research and Application* 3: 149-151.
- Wang, H., G. Cui, M. R. Luo, and H. S. Xu. 2012. Evaluation of colour difference formulae for different colour difference magnitudes. *Color Research and Application* 37: 316-325.
- Xin, J. H., C. C. Lam, and M. R. Luo. 2004. Evaluation of the crispening effect using CRT-based colour samples. *Color Research and Application* 26: 374-380.

# Jean-Philippe Lenclos' methodology of "The Geography of Colour": back to the origins and its international impact

**Verena M. Schindler**

Art and Architectural Historian, Zollikon, Switzerland  
Co-Chair of the AIC Study Group on Environmental Colour Design  
ecd.studygroup@yahoo.com

## ABSTRACT

In the *Proceedings of the International Colour Association Conference 2018* nine papers refer to Jean-Philippe Lenclos' methodology that he calls "The Geography of Colour". The authors of these nine papers come not only from European countries, but also from South America and Australia. This illustrates the international impact that The Geography of Colour still has today. The aim of this paper is to explore the origins, sources and methodology Lenclos developed in the early 1960s. Starting in 1965, he completed a systematic inventory of local colours and architectural traditions appearing within the different regions of France. Considering colours as belonging to the geography, history, and cultural identity of a place, The Geography of Colour was then applied beyond his native country to other European countries and to other continents as well. In each case, The Geography of Colour was applied to study the colours of a village, town, region, or country.

**Keywords:** *colour culture, colour methodology, urban colour, landscape colour, the geography of colour, Jean-Philippe Lenclos*

## INTRODUCTION

The very beginnings of Lenclos' methodology occurred almost sixty years ago. In the early 1960s, the French colour designer Jean-Philippe Lenclos started developing a systematic approach to dealing with the increasing complexity of colour found in natural and urban landscapes that he eventually called "The Geography of Colour".

This paper begins by exploring the way that Lenclos' broader colour research strategy developed in The Geography of Colour is discussed today. Browsing through the *Proceedings of the International Colour Association (AIC) Conference 2018*, the result is revealing. Nine out of a total of 137 published papers mention Lenclos. The authors of these nine papers come not only from European countries, but also from South America and Australia (Figure 1): Byron Mikellides (United Kingdom); Catarina Diz de Almeida and Cristina Caramelo Gomes (Portugal); Agata Kwiatkowska-Lubańska and Justyna

Tarajko-Kowalska (Poland); Xavière Ollier (France); Saara Pyykkö (Finland); Esra Küçükkılıç Özcan and Rengin Ünver (Turkey); Malvina Arrarte-Grau (Peru); Aléxia Brasil and Ana Guerreiro (Brazil); and, Annamaria di Cara (Australia).

The main objective of this paper is to scrutinize the origins and sources of how the methodology came into being, and furthermore to outline the several different methods comprising the chromatic methodological approach. Lenclos' research carried out over the decades resulted in a distinguished body of publications co-authored with his wife Dominique Lenclos (1942-2012). The most important books are *Les couleurs de la France: maisons et paysages* (1982); *Les couleurs de l'Europe: géographie de la couleur* (1995); *Couleurs du monde: géographie de la couleur* (1999); and, *Couleurs de la Méditerranée: géographie de la couleur* (2016).

In his AIC 2018 keynote lecture entitled "Fifty years of colourful reflections", Byron Mikellides, who has been teaching at Oxford School of Architecture of the Oxford Brookes University (UK) since 1968, discusses the books (co-edited with Tom Porter) entitled *Colour for architecture* (1976) and *Colour for architecture today* (2009), in which Lenclos' work is published. Mikellides considers Jean-Philippe Lenclos as "the foremost colourist in the world" and praises his broad field of colour application ranging from industrial products to the environment. Mikellides also underscores that Lenclos' books "have been very influential over the past forty-five years, including our Oxford students since the 1970s" (Mikellides 2018: 42). When talking about the future of architectural colour, Mikellides quotes Lenclos who points out that the contemporary period is a very important one because colour is expressed via new materials and lighting rather than through paint. In the words of Lenclos, these features create "a new chromatic dialectic between form, space, structure and light." Talking about the city of the future, once again Mikellides discusses Lenclos' claim that the natural elements are difficult to introduce in an increasingly technology-dominated, man-made environment. From Lenclos' point of view, the link between *nature* and *technology* is *colour* because of its power to express volume, space, structure, contrast, and rhythm, as well as induce a poetic dimension.

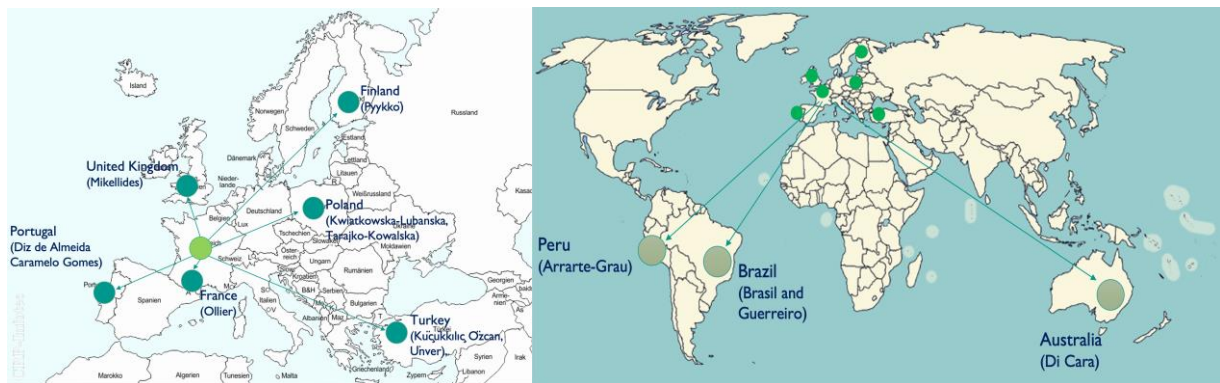

Figure 1: The European (left) and the worldwide (right) impact of Jean-Philippe Lenclos' The Geography of Colour methodology on colour research as indicated by the papers published in the AIC 2018 conference proceedings.

## THE GEOGRAPHY OF COLOUR METHODOLOGY

### Origins

Jean-Philippe Lenclos studied at the Art School in Lille, then cabinet-making at École Boulle in Paris and also at École Nationale Supérieure des Arts Décoratifs (ENSAD), followed by travelling to Japan



where he enrolled in 1961 at the Kyoto School of Art for two years to study architecture –a crucial, shaping experience in his biography. The idea of The Geography of Colour came into being while discovering the poetry of Zen gardens, the patina of ancient architecture, the mysterious beauty of calligraphy as well as colours that, based on contrasting lightness, revealed a whole range of black and white nuances and the harmonious flow of emptiness and fullness. In the following quotation, Lenclos describes the cultural and chromatic shock he experienced while discovering the amazing difference between the colours of his native environment and those of the Japanese landscape:

While drawing in the tiny streets of Gion Machi and in gardens and temples, Ryoan-ji, Daizen-in, Ginkaku-ji, Koke-dera..., I was seeing space anew. In the silence, I learned the whole extent of matter and the beauty of rhythms. And the precious shadows of Tanizaki helped me, by pure contrast, to measure the primacy of the light that gave life to every color. Then the idea came to me, as proof, that Japan's specific colors took part in its cultural identity. This revelation was born of the comparison with my own country of origin, the Pas-de-Calais, in the north of France where Matisse was born – a humid land where the habitat pays tribute to the bright tones of its orange tiles and brick-red façades, contrasting in a Fauvist manner with the intense green of the vegetation. (Lenclos and Lenclos 1999: 13) (Figures 2 and 3)



Figure 2: North of France: orange tiles and brick-red façades contrast in a Fauvist manner with the intense green of the vegetation. Source: Lenclos and Lenclos (1999).



Figure 3: Japan: Light and shadow, subtleties of dark and light colours, of hidden and exposed elements, the rhythm of natural materials and textures. Source: Lenclos and Lenclos (1999).

### Sources of inspiration

One of the main sources of inspiration of Lenclos' research is Nature because of its continuous interaction between permanent and ephemeral colours. The transformation of these natural elements such as light and weather conditions, seasonal changes, and vegetation create an important poetic dimension whereby colour is always present. "Landscapes and objects that

surround us daily are inhabited with tangible and concrete realities; but they are also filled with mystery [...] It happens that silence becomes music and darkness turns into light" (Lenclos and Lenclos 1990: 9) (Figure 4).



Figure 4: Permanent and impermanent colours of a landscape and the impact of light and weather conditions, and seasonal changes of the vegetation. Source: Lenclos and Lenclos (1990).

Another source of inspiration is Art. For example, the painting *La cour de ferme à Chassy* [Farm yard in Chassy] of the French artist Balthus (1908-2001) had a strong impact on Lenclos because of the way light is represented: the strange quality of its colours, its delicate shades, and its mysterious lightness scale (Figure 5).



Figure 5: Balthus, *Cour de ferme à Chassy*. 1954. Oil on canvas, 75 × 92 cm. Source: Lenclos and Lenclos (1990).

## Research

For ten years Jean-Philippe Lenclos was artistic director of the paint company IPA Peintures Gauthier before creating supergraphics and founding his own firm, the Atelier 3D Couleur, in Paris in 1978. As a freelancer he had already worked for Peintures Gauthier in 1959, before winning a scholarship awarded by the Japanese Government. Starting in 1965, a systematic chromatic inventory of the regional habitat in France was conducted in order to synthesize the characteristic colours of a region. Expanding from the English Channel to the Mediterranean Sea, and from the Alps to the Atlantic, the European country revealed a stunning chromatic diversity varying from one region to another resulting in greatly contrasting palettes. The Geography of Colour, a "methodology based on the objective observation of colour phenomena on a given site suitable for any type of architecture"

(Lenclos and Lenclos 1990: 10), also considered general features such as the natural environment, light and climatic conditions, local construction materials as well as popular traditions that influence the colours of regional architecture.

Indeed, the first seventy to hundred pages of his books discuss key colour phenomena. Recalling that pure colour does not exist in a landscape due to the interaction of architectural colour, mineral, aquatic and vegetal surroundings, daylight, sky colour, and volume, Lenclos emphasizes that the colour of architecture is an essential and constituent element of a landscape.

Referring to Maurice Dérivé, Jacques Fillacier and Edwin H. Land some fundamentals about colour vision, the eye, and the three colour attributes are covered. In terms of colour order systems Michel-Eugène Chevreul and Johannes Itten are discussed. An admirer of the work of Claude Monet, Paul Signac and Henri Matisse, Lenclos points at the subtleties of chromatic variation under different light conditions. From his point of view, contrast is the most important feature of a landscape, and he refers to Itten's theory of the seven kinds of colour contrast. Other senses are addressed when talking about texture and the emotional effects of colour.

In the context of The Geography of Colour methodology many observations described in his texts are interesting. For instance, Lenclos claims that colour is a powerful force but difficult to master because even the perfectly trained eye is exposed to colour illusions (as Josef Albers used to say). Another intriguing remark is about the influence of daylight on the appearance of a colour sample. If the (sun)light is too strong the saturation of a colour sample will appear less saturated. And if the illumination is low some colours will turn pale or green. Another crucial observation concerns the way an architectural colour is defined. According to Lenclos, the experience of the colour designer allows the designer to predict the colour of a sample applied on a monumental surface. A colour sample will always be more saturated than on a large scale, i.e., a saturated façade colour will appear much lighter at a distance of hundred metres than at the reach of the hand. Therefore, he advises colour designers to consider this phenomenon in an architectural model by modifying the lightness (or value) of the selected colour, which should be lighter than the colour applied on the building façade. Another interesting observation concerns the colours of old cities, where saturated colours are applied on building façades to soften the reflection of bright sunshine, with the result that the more intense the colours of the façades are, the more saturated the colours of the doors become.

Another important distinction concerns the different scales that play a crucial role in the application of the methodology. There is the general palette (*palette générale*) and there is the specific palette (*palette ponctuelle*). The general palette usually includes the colours of the façades and roofs because they represent the dominant colours of a landscape. A detailed discussion of the building materials includes the vegetal materials (wood and thatch); the mineral materials (earth and sand); raw materials, manufactured materials, rammed earth, cob, tile, and brick; stone as a raw material; stonework, fake masonry, coated masonry, composite masonry.

The specific palette provides a complement to the first one and contributes to improving and emphasizing the quality and liveliness of a building. This second palette includes the colours of smaller elements such as doors, windows, and shutters; windowsills and thresholds; quoins; lintels; fireplace foundations; building bases. What finally matters is the quantitative and qualitative relationship of the two palettes.

An additional important issue concerns colour and paint. Paint is often applied either to protect the building materials or to embellish the façades or to make the houses neat and tidy. The use of colour also has a sociocultural signification, a symbolic meaning, or is the revelation of an individual expression. A detailed discussion also includes the pigments (metallic, organic, and mineral).

## Methodology

The Geography of Colour methodology was developed for different purposes. One of the aims is to identify and preserve the chromatic richness and variety of the architectural heritage of villages, ancient city cores, and towns. The colour charts also serve to define the colours of the building renovation materials. Another aim is to avoid the "visual pollution" that often arises from rapid housing and urban development by conceiving a general colour chart for new towns and new urban landscapes. Colour of new buildings is today no longer the result of the use of materials found on-site. As well, the final colour charts synthesising the existing colours found on a specific site are not only a witness of passing time but more often a point of departure for conceiving new harmonies that are nonetheless related to the traditional habitat. According to Lenclos, the main objective is to propose a methodology that helps find solutions based, not only on intuitive and subjective evaluation, but on an overall study of the fundamental colour elements of a landscape, including the permanent and impermanent colours.

The methodology includes two main stages. Broadly speaking there is a first phase that deals with the analysis of a site, and a second phase that deals with the visual synthesis of the chromatic inventory (Table 1).

<i>First phase</i>	<i>Second phase</i>
<p><i>Analysis of a site</i></p> <ul style="list-style-type: none"> <li>• Inventory of colour data:               <ul style="list-style-type: none"> <li>○ Collecting material samples;</li> <li>○ Identifying colours using tools (colour fan, etc.);</li> </ul> </li> <li>• Measuring the lightness degree of the materials on-site;</li> <li>• Creating colour pencil drawings, watercolours;</li> <li>• Making notes, recording colour references;</li> <li>• Taking photographs of the site;</li> <li>• Reproducing with paint the colours found on-site in the studio (creating colour swatches).</li> </ul>	<p><i>Visual synthesis of the chromatic inventory</i></p> <ul style="list-style-type: none"> <li>• Classifying the colour samples:               <ul style="list-style-type: none"> <li>○ General palette (<i>palette générale</i>);</li> <li>○ Specific palette (<i>palette ponctuelle</i>);</li> <li>○ Colour portait of a façade;</li> <li>○ Quantitative palette;</li> <li>○ Qualitative palette;</li> <li>○ Narrative palette.</li> </ul> </li> <li>• Colour chart synthesis (<i>tableau de synthèse</i>).</li> </ul>

Table 1: Content of The Geography of Colour methodology.

## Analysis

During the initial on-site colour analysis, colours are precisely documented in two different and complementary ways: (1) collecting material samples (Figures 7b, 7c, 7f); and (2) identifying colours using tools (e.g., a colour fan). Material samples show the original colours of the buildings and their surroundings. Collecting material samples (if possible) represents the tactile dimension of the methodology. In the studio, they are made into gouache colour swatches to create colour ranges (Figures 7b, 7c).

Complementary elements of the analysis include creating watercolours and colour pencil drawings of the situation (Figure 6a). Lenclos claims that these techniques are the most efficient ones for capturing the principal colour characteristics of a house or an architectural ensemble. Notes and colour references can be included.

Photography is a means of communicating information. Pictures also help record visual details and are important iconographic documents, but they are not calibrated and cannot be used to identify and measure the exact colours (Figure 6e).



Figure 6: Colour study of Viviers, France: a) watercolour of the situation, with colour notations; b) colour portraits of façades; c) quantitative colour schemes; d) qualitative colour range; e) photograph, general view of the site; f) colour synthesis charts (tableaux de synthèse). Photo: Courtesy Jean-Philippe Lenclos.



Figure 7: Le Morayshire, Scotland, elements of the analysis and synthesis: a) narrative palettes; b) material samples of the façades, with corresponding colour swatches; c) material samples found on-site, with the colour range of the blues; d), e) general palettes: colours of the façades; f) material samples of the surroundings, with corresponding colour swatches. Photo: Courtesy Jean-Philippe Lenclos.

## Synthesis

The general palette assembles twenty-five façade colours organized according to the lightness scale, from the darkest to the lightest (Figures 7d, 7e).

The specific palette can also be organized in a similar way. The colours of the shutters, doors, and window frames each would form an individual palette, organized according to the colour families or hues. The specific palette can also assemble the colours of the doors, window frames, shutters, bases, and roofs on one single plate. The colours are then not represented as squares, but in their specific proportion and simplified form.

There are different ways of presenting the colours:

- Each square represents a synthesizing portrait of the façade of a building (Figure 6b).
- The quantitative and proportional relationship of colours is shown in a square scheme (Figure 6c).
- Important also is the presentation of the ensemble of the qualitative colours (Figure 6d).

The narrative palette is the representation of a personalized synthesis that includes particular details found on the façades such as the characteristic framing features of the windows and the doors (Figure 7a).

The *tableau de synthèse* is a synthesizing colour chart, which indeed is a simplified narrative palette (Figure 6f). It is an iconic visualization that makes comparisons easier and clearer.

## CONCLUDING REMARKS

In 1970, the Color Planning Center of Tokyo commissioned Lenclos to do a study of the colours of the city of Tokyo based on his newly developed methodology. The results were published in Japan and also in France.<sup>1</sup> As well, the first publications on The Geography of Colour appeared in France starting in 1969.<sup>2</sup> A series of ten articles presenting the characteristic colours of different regions of France included his famous plates that illustrate the colours of twenty-five façades of buildings of a specific geographic site arranged in a square format. These tableaux, representing his colour synthesis, have become iconic, instantly recognizable.

The Centre Georges Pompidou in Paris officially opened on 31 January 1977. Shortly thereafter, from 26 May through 27 June 1977, a solo exhibition entitled *Géographie de la couleur: de l'analyse de site au concept d'application: les recherches de Jean-Philippe Lenclos* [Geography of Colour: from the site analysis to the application concept, the research of Jean-Philippe Lenclos] was organized by the Centre de Création Industrielle (CCI) and co-curated by Ubaldo Klug from the Centre Pompidou. In the press announcement Lenclos writes,<sup>3</sup> "Indeed, colour is a specialty, it is a precise language, which responds to laws which were, until a short time ago, little known. For my part, it is a question of

<sup>1</sup> The first article on Lenclos' colour study of Tokyo appeared in France, entitled "Design urbain. Tokyo" in *La Maison de Marie Claire*, 1971 (57): 49. In Japan, *Couleurs de Tokyo* was published by the Color Planning Center in Tokyo, 1972 (32-33). A larger article entitled "Couleurs et paysages" was published in *L'architecture d'aujourd'hui* (L'homme et le territoire), 1972 (164): 41-44. And in Belgium also appeared the article "Les couleurs de Tokyo" in *Neuf* 1976 (63): 54-55.

<sup>2</sup> The first articles on The Geography of Colour methodology published in France were: "La maison à vos couleurs" in *Maison de Marie Claire*, 1969 (29); "Les matériaux naturels de la couleur" in *La Maison de Marie-Claire*, 1973 (74); and, "Les couleurs de la France" in *La Maison Française*, 1973 (276-287).

<sup>3</sup> "Géographie de la couleur: recherches de Jean-Philippe Lenclos et conception d'Ubaldo Klug", exposition du 26 mai au 27 juin 1977. Communiqué de presse, 1977. Source: The Centre Pompidou's Archive.

deciphering the mechanisms and applying them with analysis and method. Method as objective as possible, at least that's what my works tend to offer without forgetting the intuitive and poetic dimension, essential and always present."

In 1981, Jean-Philippe Lenclos was granted a Chevalier des Arts et Lettres (Knight) award by the French Minister of Culture Jack Lang for his significant contributions to the arts. His book *Les couleurs de la France: Maisons et paysages* (first edition published in 1982), has received four different prizes. Today one hundred seventy of his works are included in the Collection of the Musée National d'Art Moderne Centre Georges Pompidou in Paris, France.

As well, The Geography of Colour methodology has become a fundamental procedure for many colour designers and researchers worldwide. Lenclos' publications on The Geography of Colour have become standard reference books for anyone interested in colour research, design, architecture, urban planning and urban design, and generally in built and man-made environments.

## ACKNOWLEDGEMENTS

My special thanks go to Jean-Philippe Lenclos for the various conversations with him in 2019, and to Prof. Dr. José Luis Caivano for his kind invitation to deliver a keynote lecture at the AIC Midterm Meeting 2019 in Buenos Aires.

## REFERENCES

- AIC (International Colour Association). 2018. *Proceedings of the International Colour Association (AIC) Conference 2018*, Lisbon, 25-29 September 2018, M. Gamito and M. J. Durão, eds. Newtown, NSW: International Colour Association.
- Arrarte-Grau, M. 2018. The scales of colour perception in architecture. In: AIC 2018, 71-76.
- Brasil, A., and A. Guerreiro. 2018. Lisbon, a colour experience from sketch to illustration. In: AIC 2018, 291-295.
- Di Cara, A. 2018. Sensory experience contours of the natural and built environment: Lisboa – Sydney. In: AIC 2018, 87-91.
- Diz de Almeida, C., and C. Caramelo Gomes. 2018. Historic urban landscape: construction of a methodology for integrated colour proposals. In: AIC 2018, 53-58.
- Jean-Philippe Lenclos: The geography of color*. 1989. Tokyo: Car Styling 71 (1-2) Special Edition; San'ei Shobo Publishing Co.
- Jean-Philippe Lenclos: painter & designer*. 2017. Text by Jean-Philippe Lenclos. Preface by Jianming Song. Introduction by Cloé Pitiot. Jinan: Shandong Fine Arts Publishing House.
- Küçükılıç Özcan, E., and R. Ünver. 2018. Environmental colour mapping and a case study for Istanbul, Beşiktaş. In: AIC 2018, 159-164.
- Kwiatkowska-Lubańska, A., and J. Tarajko-Kowalska. 2018. Survey on perceived façade colours using colour samples from ready-made plaster collection for southern Poland. In: AIC 2018, 133-137.
- Lenclos, J.-P., and D. Lenclos. 1990. *Les couleurs de la France: maisons et paysages*, with a preface by Georges Henri Rivière. Antony: Éditions du Moniteur. First edition 1982.
- . 1995. *Les couleurs de l'Europe: géographie de la couleur*, with prefaces by Michel Pastoureau and Tom Porter. Antony: Éditions du Moniteur.

- . 1999. *Couleurs du monde: géographie de la couleur*, with a preface by François Barré. Antony: Éditions du Moniteur. English edition, *Colors of the world: the geography of color*, with a preface by François Barré, translated from the French by Gregory P. Bruhn. New York: W. W. Norton & Company.
- . 2016. *Couleurs de la Méditerranée: géographie de la couleur*, with a preface by Jean-Jacques Terrin. Antony: Éditions du Moniteur.
- Mikellides, B. 2018. Fifty years of colourful reflections. In: AIC 2018, 39-44.
- Ollier, X. 2018. Magical realism and chromatic archeology: the colourist and Procida. In: AIC 2018, 605-611.
- Porter, T., and B. Mikellides. 1976. *Colour for architecture*. London: Studio Vista.
- . 2009. *Colour for architecture today*. London: Taylor & Francis.
- Pyykkö, S. 2018. The main elements of the colour design process of a new neighbourhood – The case Koivusaari in Helsinki. In: AIC 2018, 171-175.
- Schindler, V. M., Y. A. Griber, and M. Bouchier. 2020. The French period in the history of environmental colour design. In: *Proceedings of the International Colour Association (AIC) Conference 2019, Buenos Aires, 14-17 October 2019*, J. L. Caivano, ed. Newtown, NSW: International Colour Association, 544-549.



## Citation for Prof. Hirohisa Yaguchi: the AIC Deane B. Judd Award 2019 recipient

### Ming Ronnier Luo

Zhejiang University, Hangzhou, China  
m.r.luo@leeds.ac.uk

Prof. HIROHISA YAGUCHI had a distinguished academic career. He graduated at the Department of Photographic Engineering at Chiba University in 1974 and received his PhD with a thesis title of study on additivity of brightness in luminous efficiency, at Tokyo Institute of Technology, supervised by Prof. Mitsuo Ikeda in 1980. Based on his PhD thesis, he published his most cited paper, “Subadditivity and superadditivity in heterochromatic brightness matching” in *Vision Research*.

In 1982, he moved to National Research Council (NRC) in Ottawa, Canada, and worked with the late Dr. Günter Wyszecki as a research associate from 1982 to 1986. At the NRC, he researched the fundamental aspect of color vision such as color matching. He measured his own color matching functions, luminous efficiency and opponent-color response function using the NRC Stiles Trichromator. His work at NRC was presented at the Midterm Meeting of AIC “Wyszecki-Stiles Memorial Symposium on Color Vision Models”, Florence, Italy, in 1987, and the paper entitled “Signal transformations from the cone stage to the neural coding stage” was published in *Die Farbe*.

He then went back to Chiba University in 1986 as an assistant professor at the Department of Information and Image Sciences. In 1995, he became a professor. During the professor period, he also served as head of the Department. He retired from Chiba University in 2017, at the same time he was honored as professor emeritus. He also served as an associate editor of the journal *Color Research and Application* from 1999 to 2017.

He has published more than 150 scientific papers and 10 books in the field of color and imaging in his carrier. His major scientific achievements covered a large scope of topics including color vision, color discrimination, color deficiency, luminous efficiency, the HK effect investigation, colour appearance modelling, colour constancy, colour name rendering and skin colour. I am particularly impressed in his research on the investigation of the change of colour appearance under photopic, mesopic and scotopic vision, and finally make a model for mesopic vision.

He was also a great educator, taught modules of color vision, photometry, colorimetry, visual information processing, color reproduction, universal color design, fundamental colorimetry and its application to imaging science. He successfully supervised 15 PhD students. He also teaches part time at RMUTT, Thailand, and National Taiwan University of Science and Technology, Taiwan.

He has been very active in color societies, particularly in the CIE and the AIC, and made great contribution as the chairman of CIE Technical Committee TC1-90 to publish the Technical Report CIE 227:2017 *CIE 2107 Color fidelity index for accurate scientific use*. The index was the new color rendering evaluation methods. It is expected to replace the current CIE colour rendering index (CIE-Ra) in the near future. He was past president of CIE-Japan. He was awarded the CIE award in 2009. He also made great contribution to the International Colour Association (AIC). The most important ones included to host two AIC meetings in Japan and made them great successes.

## Individual color vision

**Hirohisa Yaguchi**

Chiba University, Chiba, Japan  
yaguchi@faculty.chiba-u.jp

### ABSTRACT

It is known that color vision differs from person to person. The cause is considered to be various factors such as the lens ocular taint due to aging, the difference in the sensitivity to cones, and the difference in the visual information processing from retina to brain. Such individual differences cause the problem that the colorimetric match does not necessarily correspond to the match of the actual color appearance. In this paper, I will discuss the individual differences in color vision while introducing various visual functions obtained from myself. At first, I will introduce the outline of the quantitative processing of visual information obtained based on the analysis of my visual functions. Secondly, I will discuss individual difference in luminance and brightness perception. Finally, I will discuss a problem of the observer metamerism caused by the individual difference in the spectral sensitivity of cones, particularly for the anomalous trichromats and the aged people.

**Keywords:** *color matching functions, luminous efficiency function, Helmholtz-Kohlrausch effect, observer metamerism, anomalous trichromats, aging effect*

### INTRODUCTION

The most widely used CIE color system is based on a single observer, called the CIE 1931 standard colorimetric observer. However, color vision is more or less different in individuals. In the process of visual perception from light entering the eye to color perception, the following are considered as factors of individual differences (see Figure 1):

- optical density of ocular media such as crystalline lens and macular pigment,
- difference in visual pigments of the L-, M-, and S-cones that cause color abnormally,
- density ratio of the L-, M-, and S-cones,
- visual processing at higher levels than cone photoreceptors.

The first stage of color vision is light absorption in the cone. The light that enters the eye is partially absorbed by optical media such as the crystalline lens and macular pigments before absorbed by cones. Therefore, the amount of light absorbed by cones is influenced by the optical density of lens and macular pigments in addition to the spectral absorption of the cone visual

pigments. Spectral sensitivity of cone is the most fundamental element of color vision, but it is defined for light in front of the cornea and includes spectral absorption of the lens and macular pigments. CIE (2006) based on Stockman and Sharpe (2000) defined the cone fundamentals as the relative spectral sensitivity of cone receptors as measured in the corneal plane. Also, it is known that the optical density of the lens increases with age. So, the CIE2006 provides age-dependent cone fundamentals. It can be said that CIE1931XYZ, CIE1964 $X_{10}Y_{10}Z_{10}$ , CIE2006LMS, and CIE2015 $X_F Y_F Z_F$  specify color in this first stage. The second stage is separation of luminance and opposite color information by neural coding process where the signal from the cone passes through the horizontal cells and ganglion cells in the retina, and further through the lateral geniculate nucleus to the primary visual cortex. In order to quantitatively examine what kind of processing is being performed at this stage, it is necessary to measure various visual functions using a single observer in order to exclude individual differences. Uniform color spaces, such as the CIE1976 $L^*a^*b^*$  and the CIE1976 $L^*u^*v^*$  correspond to the second stage. The final processing is a stage that finally produces color appearance as expressed by three attributes of color such as brightness, colorfulness, and hue, or color names. The color appearance in this final stage will be further accumulated by factors of individual differences. The CIE color appearance model, CIECAM02 tries to specify color at the final stage of color vision.

The present paper proceeds along this color vision processing. The first is the spectral sensitivity of the cone. Although it is difficult to obtain the spectral sensitivity of the cone, the most accurate method is to derive it by linear transformation of the color matching function. Let's start with the measurement of the color matching function.

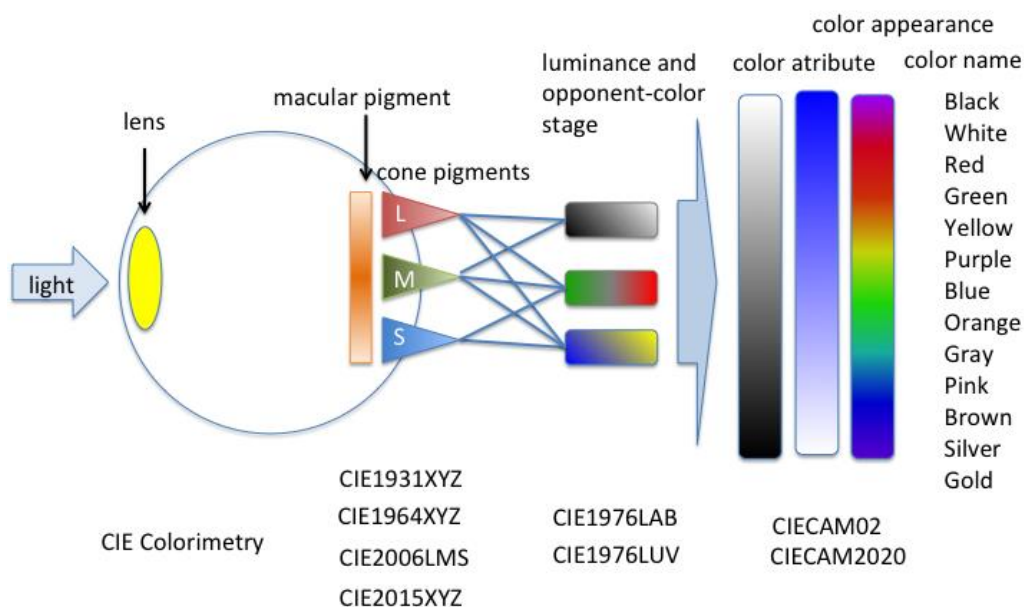

Figure 1: Factors of individual difference in color vision.

## COLOR MATCHING FUNCTIONS AND THE SPECTRAL SENSITIVITIES OF CONES

The color matching function directly reflects the spectral sensitivity of the cone. The color matching function is obtained by a color matching experiment, in which monochromatic light of equal energy is color-matched by a mixture of red, green and blue primary stimuli. The colorimetric function is a tristimulus value at this time expressed as a function of wavelength. The color matching function is

the most basic color vision characteristic because it represents the first stage of color vision processing.

I had an opportunity to work with Dr. G. Wyszecki at National Research Council Canada. There was the NRC Trichromator which was originally designed by Dr. W.S Stiles. During my stay at NRC from 1982 to 1986, Yaguchi (1987) measured many kinds of visual functions using my own eye. Those were the color matching functions, the spectral luminous efficiency functions by heterochromatic flicker photometry, and the opponent-color response functions by hue cancellation method. Color matching functions were measured by two methods; the maximum saturation method, and the Maxwell method. In the maximum saturation method, a test monochromatic stimulus presented in one half of the bipartite field is desaturated by the minimum amount required of one of the three primaries. The mixture of the test stimulus and the desaturation primary is color-matched by an appropriate mixture of the remaining two primary stimuli appearing in the upper half of the bipartite field. In the Maxwell method, a fixed reference stimulus, usually white, is presented in the upper half of the bipartite field. In the lower half, a mixture of a monochromatic test stimulus and two of the three primary stimuli is presented. The wavelength of the test stimulus determines which two of the three primaries must be added to the test stimulus. In the Maxwell method, a color match is always achieved at the reference white. On the other hand, a color match by the maximum saturation method is achieved at the chromaticity near test monochromatic color. If the proportionality and additivity law hold strictly, the color matching functions derived from the Maxwell method must be identical to those derived by means of the maximum saturation method. The red and green color matching functions were not much different from the maximum saturation method to the Maxwell method. On the other hand, the blue color matching functions were different between two methods in the short wavelength region. A similar difference was also shown in Wyszecki and Stiles data (1967).

In order to make a color vision model, the spectral sensitivity of cones must be determined. Cone sensitivity curves were determined according to the following four conditions:

1. The cone sensitivity functions should be linear combinations of color matching functions.
2. The cone sensitivities should be positive values over the whole wavelength region.
3. The cone sensitivity curve should have a single peak.
4. A shape of the cone-sensitivity curve is similar to that of the  $\pi$  mechanism developed by Stiles (1953).

The short-wave sensitive cone (S-cone) is similar to the  $\pi_1$ , the middle-wave sensitive cone (M-cone) is similar to  $\pi_4$ , and, the long-wave sensitive cone (L-cone) is similar to  $\pi_5$ . The obtained cone sensitivity functions are presented in the following equations,

$$L(l) = 0.303\bar{r}(l) + 0.579\bar{g}(l) + 0.0091\bar{b}(l), \quad (1)$$

$$M(l) = 0.0223\bar{r}(l) + 0.807\bar{g}(l) + 0.0249\bar{b}(l), \quad (2)$$

$$S(l) = 0.0005\bar{r}(l) - 0.0203\bar{g}(l) + 1.000\bar{b}(l). \quad (3)$$

The cone sensitivity functions are normalized at the peak wavelengths. The color matching functions,  $\bar{r}(\lambda)$ ,  $\bar{g}(\lambda)$ , and  $\bar{b}(\lambda)$ , are obtained by the maximum saturation method. Since the blue color matching function by the Maxwell method is deviated from that by the maximum saturation method, another S-cone sensitivity function  $S'(\lambda)$  was determined by the following equation with the Maxwell color matching functions,

$$S(l) = 0.0016\bar{r}'(l) + 0.0663\bar{g}'(l) + 0.955\bar{b}'(l). \quad (4)$$

By the way, the linear transformation formula from color matching function to the CIE (2006) cone fundamentals is expressed by the following formula,

$$\bar{l}_{10}(l) = 0.1923\bar{r}_{10}(l) + 0.7495\bar{g}_{10}(l) + 0.0676\bar{b}_{10}(l), \quad (5)$$

$$\bar{m}_{10}(l) = 0.0192\bar{r}_{10}(l) + 0.9409\bar{g}_{10}(l) + 0.1138\bar{b}_{10}(l), \quad (6)$$

$$\bar{s}_{10}(l) = 0.0105\bar{g}_{10}(l) + 0.9914\bar{b}_{10}(l). \quad (7)$$

These formulae are derived from 10° field data, but the definition of the color matching function is the same as Yaguchi (1987), so the coefficients can be compared. Comparing the coefficients of Yaguchi (1987) and CIE (2006), they seem to be almost similar.

### OPPONENT COLOR STAGE

The signal from the cone is then transmitted to the horizontal cells and ganglion cells, where the information is separated into luminance information and color information. There are two types of color information: the red-green opponent color and the yellow-blue opponent color. A psychophysical method to measure the spectral sensitivity of the opponent color response was first developed by Jameson and Hurvich (1955). This is a so-called hue cancellation method. I measured my own opponent color response functions by the hue cancellation method with the NRC Trichromator used for measurement of the color matching functions. The result of estimating the opposite color response functions with my own spectral sensitivities of cone are shown in the following equations,

$$r/g(l) = 2.745L(l) - 3.402M(l) + 0.797S(l), \quad (8)$$

$$y/b(l) = \left[ 0.991L(l) - 0.021M(l) \right]^{5.4} - 2.217S(l). \quad (9)$$

The r/g opponent-color response function was fitted on the assumption of the linear transformation by the cone signal as Eq. (8). In this case,  $S'(\lambda)$  instead of  $S(\lambda)$  was used for the S-cone. The y/b opponent-color response function was, however, not well fitted by the linear transformation hypothesis. Therefore, we must introduce a non-linear transformation hypothesis for the y/b opponent color process. The non-linear transformation suggested by Werner and Wooten (1979) was applied in Eq. (9). In my case, the coefficient for  $M(\lambda)$  is negligibly small, which means that the M-cone could not be transformed to the y/b opponent-color process. It is suggested that the r/g opponent-color channel is linearly processed by the transformation of cone signals, and the y/b opponent-color channel is non-linearly processed by the cone signals of the L-cones and S-cones.

### LUMINANCE AND BRIGHTNESS

Luminance is defined by multiplying the spectral radiance of the stimulus with the weighting of the standard spectral luminous efficiency function CIE  $V(\lambda)$ . Luminance is a measure of brightness, but it often happens that luminance and brightness do not correspond with each other. One of the causes is the individual difference in the spectral luminous efficiency function, and the other is the difference

in the judgment criteria of luminance and brightness. The CIE  $V(\lambda)$  used to define the luminance was mainly measured by the heterochromatic flicker photometry (HFP). On the other hand, the spectral sensitivity of brightness is measured by heterochromatic brightness matching (HBM) that directly compares the brightness of reference light and monochromatic light.

I have measured my own luminous efficiency function by HFP. The experimental data was curve-fitted by the least squares method on the assumption that the luminous efficiency function by HFP is a linear combination of the spectral sensitivities of cone. The luminous efficiency function  $a(\lambda)$  predicted by the linear model is as follows,

$$a(\lambda) = 0.515L(\lambda) + 0.512M(\lambda) . \quad (10)$$

There is no contribution of the S-cone. An actual coefficient for  $S(\lambda)$  by the least squares fitting was -0.002. Recently, CIE (2015) has been released the spectral luminous efficiency function based on the cone fundamentals as the following equation,

$$V_F(l) = 0.690\bar{l}(l) + 0.348\bar{m}(l) . \quad (11)$$

Since the spectral sensitivities of the L- and M-cone in Eqs. (10) and (11) are normalized with the maximum values, the coefficients could be considered to correspond to the density ratio of L cone to M cones of each observer. Therefore, the density ratio between the L cone and the M cone is 1: 1 in my case of Eq. (10) and about 2: 1 for the average observer of CIE 2006 in Eq. (11). Thus, the density ratio between the L cone and the M cone may be considered as one of the causes of individual difference in the spectral luminous efficiency function related to luminance.

As an example of individual differences in the visual processing, let us discuss the issue of luminance and brightness mismatch. It often happens that the luminance defined with the standard spectral luminous efficiency  $V(\lambda)$  does not necessarily correspond to the actual brightness. When two light stimuli with the same luminance but different colors are compared, the more saturated color stimuli appear brighter. This phenomenon is called the Helmholtz-Kohlrausch effect. Yaguchi and Ikeda (1982, 1983, 1983a) found that the H-K effect could be explained by chromatic contribution to brightness, because when two colors of the opponent-color pair were mixed, a reduction type of additivity failure was observed. The degree of intrusion in the brightness of the chromatic component could be analyzed by comparing the spectral luminous efficiency functions of the HBM and the HFP for each observer. There are many possible causes in individual variations of visual functions such as color-matching functions. The spectral absorption of the eye lens and that of macular pigments could be considered to be main causes. The absorption of ocular media, however, affects both HFP and HBM. With regard to the difference between the luminous efficiencies obtained by the two methods, the effect of the ocular media is canceled out. Yaguchi et al. (1993) measured the luminous efficiency functions by the two methods with 16 observers. It was found that the difference between the luminous-efficiency functions by these two methods is predicted by only two principal components. The first component could be related to the overall contribution of chromatic channels, that is, the contribution of both red/green and yellow/blue chromatic channels to brightness. The second component shows positive values in the short-wavelength region and negative values in the long-wavelength region. The second principal component changes the balance of the amount of the contribution of the chromatic channel at the short wavelength region and that at the long-

wavelength region. Individual differences in the H-K effect could be attributed to differences in the weights of these two components. The individual weighting factor could be specified with the ratio of the luminous efficiency of HBM and HFP at two wavelengths, for example 470 nm and 660 nm.

### **OBSERVER METAMERISUM FOR AGED PEOPLE AND ANOMALOUS TRICHROMATS**

Do observers with different cone spectral sensitivities see different colors even when they see the same object? Yes, even if the colorimetric values of two stimuli with different spectral powers such as an object color and a display color are equal, different colors may be seen. It is considered to be a problem of observer metamerism, which is caused by the fact that the color matching function of a real observer is different from that of a standard colorimetric observer. As for individual differences in cone spectral sensitivity, color vision deficiencies and aging effects could be considered to be the major factors. Here, we take up the problem of observer metamerism for the anomalous trichromats and aged people.

The ITU-R recommends a color reproduction with wide color gamut in BT.2020 (ITU 2015) and BT.2100 (ITU 2017). In the recommended wide color gamut display, the chromaticity coordinates of red, green, and blue primaries, are located on the spectral locus in the chromaticity diagram. Therefore, the spectral power distributions of the primaries with a wide color gamut display have to be extremely narrow as laser lights. The tristimulus value of the color stimulus mixed with the narrow band primaries is apt to be sensitive to a variation of color matching functions. Then, the influence of the difference between the standard observer's color matching function and individual's color matching function on color appearance is larger in the wide color gamut display than in a conventional display. In 2006, CIE published the Technical Report (2006) in which the spectral sensitivity functions of cones for various aged observers, called cone fundamentals of an age dependent observer, are generalized. The cone sensitivities of short wavelength regions decrease with age due to the increase of the optical density of the lens. Yaguchi et al. (2018) propose a model of color appearance for anomalous trichromats based on the spectral shift of spectral sensitivity of cones. We assume that anomalous trichromats possess a protanomalous (green shifted) or deuteranomalous (red shifted) pigment instead of a normal L- or M-cone. Sunaga et al. (2018) and Yaguchi et al. (2018a) employed anomalous trichromat cone fundamentals and the age dependent cone fundamentals to simulate a color match between the color chip illuminated with an LED lamp and the color presented on the displays with different sizes of color gamut. We also conducted the color matching experiment of which different age observers and different type of color anomalous trichromats participated. We used a CRT display, a liquid crystal display (LCD), and a laser display, but here we will focus on a laser display with the widest color gamut and narrow primary colors.

The observer's task was to adjust the luminance and the chromaticity of the color stimulus on the display to make color match the color chips. Figure 2 shows the results of the laser display for each type of color vision. Open circles indicate the chromaticities of the test color chips. The chromaticities of all the matched colors (solid circles) shifted toward greens along deuteranopic confusion lines in observer TS who is deuteranomalous. This means that the colors on the laser display become reddish for deuteranomalous trichromats. On the other hand, in observer MA who is protanomalous, the reddish colors shifted toward reds along protanopic confusion lines, but the greenish colors shifted to diverge from it. These results indicate that the reddish colors on the laser display become greenish and that the greenish colors become reddish. Namely, the red-green saturation of the color on the laser display was decreased. We tried to explain these color shifts by a



color appearance model of anomalous trichromats proposed by Yaguchi et al. (2018). Figure 3 shows the simulation of color matching for protanomalous and deuteranomalous trichromats. The degree of anomaly is presented based on the amount of shift in the wavenumber. For example, “L'+300” in Figure 3 indicates a protanomaly where the peak sensitivity of the L-cone shifts 300  $\text{cm}^{-1}$  in wavenumber (10 nm in wavelength) toward green, and “M'-700” indicates a strong deuteranomaly where the peak sensitivity of the M-cone shifts 700  $\text{cm}^{-1}$  in wavenumber (20 nm in wavelength) toward red. The model can account for the color shift of deuteranomalous trichromats. However, it cannot account for the results of green colors for protanomalous trichromats. There may be an unknown factor in color appearance for anomalous trichromats.

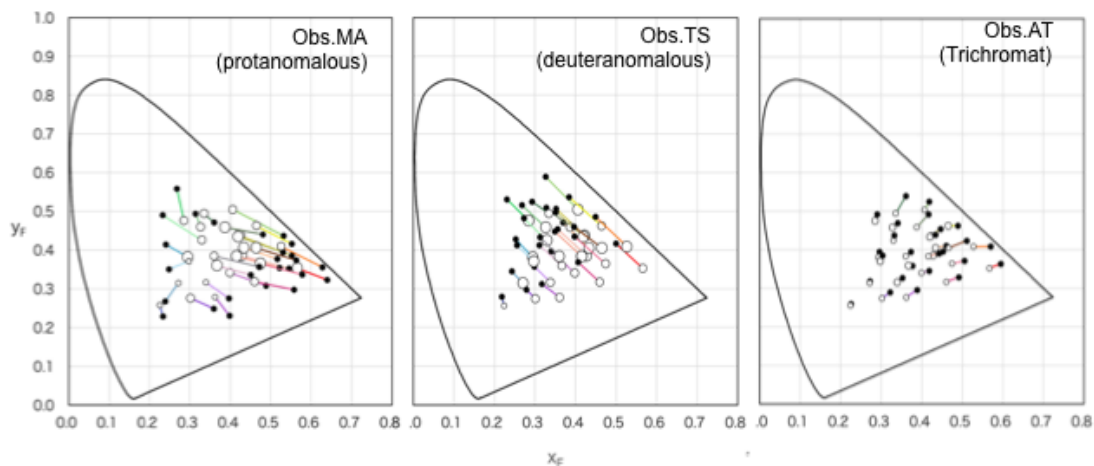

Figure 2: Results of color matching experiments of the laser display for each type of color vision.

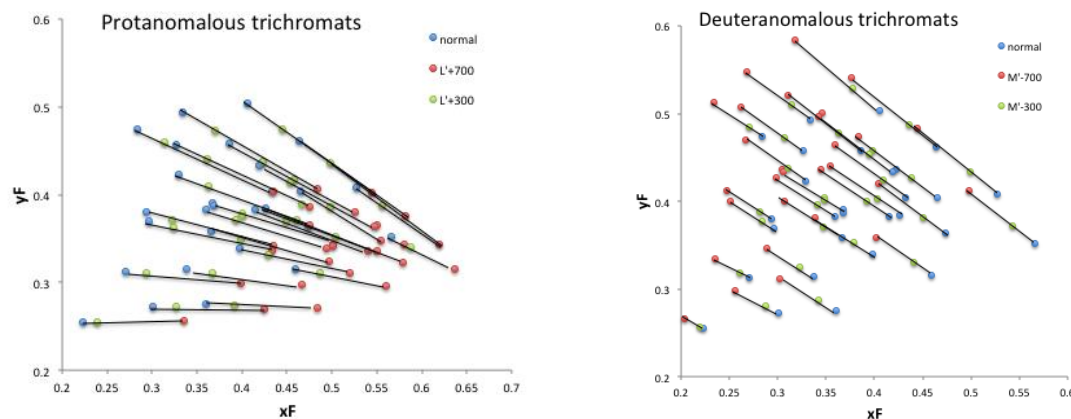

Figure 3: Simulation of color matching for protanomalous and deuteranomalous trichromats.

Next, let's look at the age effect. Figure 4 shows the simulation results of color matching points of 27 test colors on three displays for 22, 52, and 67 years old with an average observer of CIE2006, 32 years old in the CIE2015 ( $x_F$ ,  $y_F$ ) chromaticity diagram. Color matching points of display shift toward short dominant wavelength direction with increase of the age. It means that the color of the display stimulus with the same chromaticity as a color chip looks longer dominant wavelength hue compared with the hue of the color chip. This tendency appears most conspicuously in a laser display. Figure 5 shows color shifts of from color chips to the color matching points of the display for four different aged observers. The results from the youngest observer aged 22 years shows small or opposite color

shift in the blue region compared with those of older observers. The experimental results of older observer show that the chromaticity coordinates of all displays are plotted more bluish region than those of color chips, particularly in the blue color region. It means that the color of the display stimulus with the same chromaticity as a color chip looks less bluish compared with the color chip, so more blue stimulus value are needed to make a color match. Although individual differences among observers exist, the most part of experimental results are well predicted by the model of color match applied with the CIE 2006 age dependent cone fundamentals.

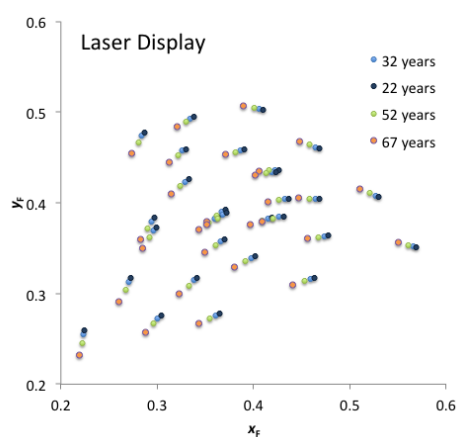

Figure 4: Simulation of color matching points for four age group observers.

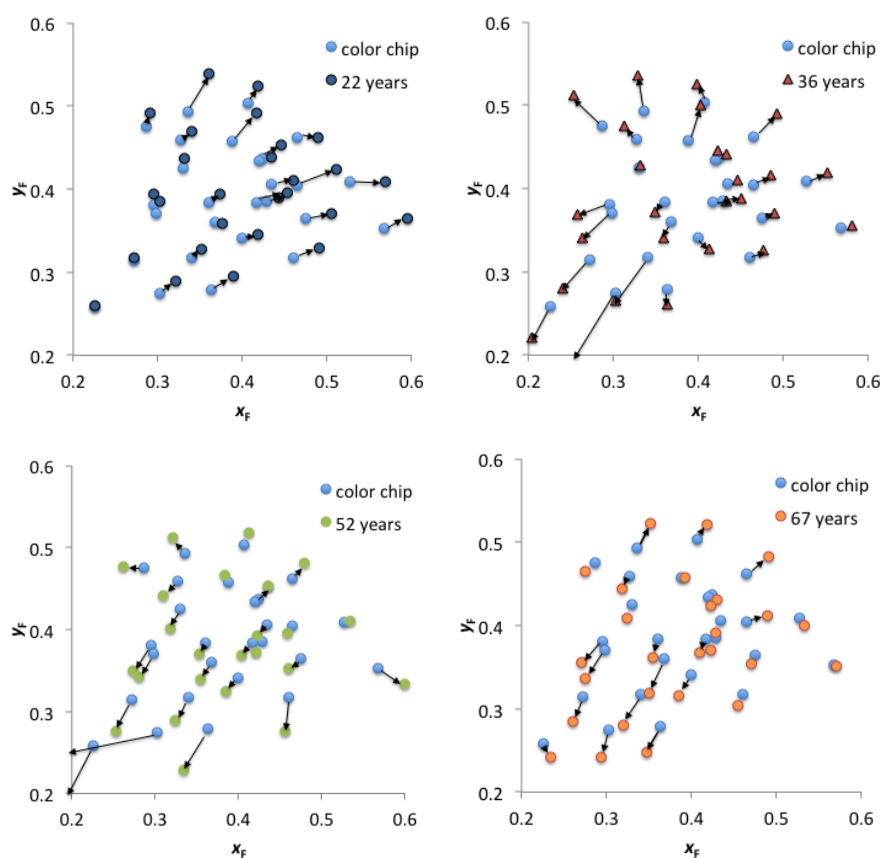

Figure 5: Shifts of color matching points from color chips to the stimuli on the laser display for four observers aged 22, 36, 52, and 67 years old.

## CONCLUSION

As mentioned at the beginning, the CIE colorimetric system has historically developed along the color vision information processing. I have mentioned that there are individual differences in each stage of the color vision mechanism. Thanks for the long-standing research and activities in CIE, the cone fundamentals for a standard observer and further the CIE2015 $X_F Y_F Z_F$  colorimetric system based on the standard cone fundamentals have been established. In the near future, it would be desirable to establish a colorimetric system for individual color vision.

## ACKNOWLEDGEMENTS

I am grateful to my collaborators, Profs. Yoichi Miyake, Satoshi Shioiri, Shoji Sunaga and Yoko Mizokami, and many students who joined our research project at Chiba University. I would also like to thank the colleagues who nominated me for the Judd award.

## REFERENCES

- CIE (Commission Internationale de l'Éclairage). 2006. Fundamental chromaticity diagram with physiological axes – Part 1. CIE Publ. 170-1:2006.
- . 2015. Fundamental chromaticity diagram with physiological axes – Part 2: Spectral luminous efficiency functions and chromaticity diagrams. CIE Publ. 170-2:2015.
- ITU (International Telecommunication Union). 2015. Parameter values for ultra-high definition television systems for production and international programme exchange. ITU-R BT.2020-2.
- . 2017. Image parameter values for high dynamic range television systems for use in production and international programme exchange. ITU-R BT.2100-1.
- Jameson, D., and L. M. Hurvich. 1955. Some quantitative aspects of an opponent colors theory. I. Chromatic responses and spectral saturation. *Journal of Optical Society of America* 45: 546-552.
- Stiles, W. S. 1953. Further studies of visual mechanisms by the two-colour threshold method. In: *Coloquio sobre Problemas Ópticos de la Visión* (Madrid, Union Internationale de Physique Pure et Appliquée) 1: 65-103.
- Stockman, A., and L. T. Sharpe. 2000. Spectral sensitivities of the middle- and long- wavelength-sensitive cones derived from measurements in observers of known genotype. *Vision Research* 40: 1711-1737.
- Sunaga, S., R. Suto, K. Katsura, and H. Yaguchi. 2018. Observer metamerism in wide color gamut display for anomalous trichromats. In: *ACA 2018, Proceedings of the 4th Asian Color Association Conference*, Chiang Mai, Thailand, 236-240.
- Werner, J. S., and B. R. Wooten. 1979. Opponent chromatic mechanisms: Relation to photopigments and hue naming. *Journal of the Optical Society of America* 69: 422-434.
- Wyszecki, G., and W. S. Stiles. 1967. *Color science: concepts and methods, quantitative data and formulae*. New York: John Wiley & Sons.
- Yaguchi, H. 1987. Signal transformations from the cone stage to the neural coding stage. *Die Farbe* 34: 67-74.

- Yaguchi, H., and M. Ikeda. 1982. Nonlinear nature of the opponent-color channels. *Color Research and Application* 7: 187-190 .
- . 1983. Contribution of opponent-color channels to brightness. In: *Colour vision*, J. Mollon and L. Sharpe, eds. London: Academic Press, 353-360.
- . 1983a. Subadditivity and superadditivity in heterochromatic brightness matching. *Vision Research* 23: 1711-1718.
- Yaguchi, H., A. Kawada, S. Shioiri, and Y. Miyake. 1993. Individual differences of contribution of chromatic channels to brightness. *Journal of the Optical Society of America A* 10: 1373-1379.
- Yaguchi, H., J. Luo, M. Kato, and Y. Mizokami. 2018. Computerized simulation of color appearance for anomalous trichromats using the multispectral image. *Journal of the Optical Society of America A* 35 (4): B278-B286.
- Yaguchi, H., R. Suto, K. Katsura, and S. Sunaga. 2018a. Aging effect of observer metamerism for wide color gamut displays. In: *ACA 2018, Proceedings of the 4th Asian Color Association Conference*, Chiang Mai, Thailand, 207-211.

## **Citation for Roy Osborne: the AIC Award for Colour in Art, Design and Environment (CADE) 2019 recipient**

### **Vien Cheung**

School of Design, University of Leeds, UK  
t.l.v.cheung@leeds.ac.uk

ROY OSBORNE was born in Bristol, England, in 1948. He studied at the West of England College of Art, Bristol (1965-1971), and Brighton College of Art, gaining a Bachelor of Arts degree in Fine Art Painting (1970) and a Postgraduate Diploma in Printmaking (1971). From 1970-1974 he taught printmaking (primarily lithography) at Brighton Polytechnic, Bradford College of Art and the Slade School of Fine Art, London. While living in Florida (1974-1975) he began writing *Lights and pigments: colour principles for artists*, bringing the subject up-to-date with innovative references to colour vision and measurement, and linking traditional art media with plastics, film, television and holography. The book was published by John Murray in 1980 and Harper and Row in 1981.

From 1980 to 1986 he was a member of the Royal College of Art Library Advisory Committee, and in 1982 assisted Hans Brill in setting up a series of ten RCA colour symposia (1983-1987). In 1985 he was the only European contributor to a colour conference at Pratt Institute, Brooklyn, organised by Nina Prantis. From 1994 to 1997 he served as AIC committee member and *Newsletter* editor, contributing to AIC conferences in Sydney (1991), Cambridge (1994), Gothenburg (1996) and Boston (2018). He was twice chairman of the Colour Group (Great Britain), 1995-1997 and 2005-2007, and in 2003 was awarded its first Turner medal for contributions to colour in art and education.

He has worked as an artist since 1968, beginning (if not completing) over 700 paintings on canvas, mostly abstract but some pictorial, and most of which attempt to explore colour in relation to form by examining such elements as figure-ground ambiguity, colour harmony, contrast illusions and optical mixing, in works that typically integrate formal aspects of straight or curved divisions, symmetry and illusions of overlapping versus transparency. Since 1970 he has contributed to over 120 group exhibitions and seven solo shows, mostly in London (50 galleries) but elsewhere throughout England, and occasionally abroad.

In 1989 he was invited by Clywd County Council to curate a touring exhibition, *From Prism to Paintbox: Colour Theory and Practice in Modern British Painting*, and assembled paintings by 70 prominent colourists working in Britain 1900-1990, collecting original statements from its living contributors. He then further studied at Chelsea College of Art, London (1990-1991), gaining a Postgraduate Diploma in the Theory of Modern Art, and at the Institute of Education, London (1992-1994), gaining a University of London Master of Arts degree in Art and Design in Education, following

which he was invited by the Institute to publish a short summary of his thesis as *Teaching colour in art: colour-form preference* (1995).

As an author he has published ten titles since 2004, starting with *Color influencing form: a color coursebook* (first drafted in 1984), proposing an exploration of colour in relation to form perception, as well as a definitive and detailed bibliography of colour, *Books on colour 1500-2000: 2,500 titles in English and other European languages* (2004), further augmented in 2012, and republished in 2015 as *Books on colour 1495-2015: history & bibliography*. He has also published original translations (from French and Italian) of early books on colour by Jean Courtois (1495), Gilles Corrozet (1527), Fulvio Morato (1535) and Giovanni Paolo Lomazzo (1584). He has recently published three illustrated books on his own artwork: *Pigments of the imagination* (2016), reorganised as *Abstract colour paintings 2008-2015* (2017), and a full *Catalogue raisonné 1968-2018* (2018). Between 2003 and 2012, he contributed significantly to six books by Don Pavey: *Colour and humanism* (2003), *Thylesius, On colour* (2003), *Don Pavey, his life and work on aesthetics and colour* (2009), *Colour symbolism, from prehistory to modern aesthetics* (2009), *Colour engrained in the mind: character profiling* (2010), and *Colour concepts, palettes and pigments* (2012).

As a writer on colour he has also contributed to *The color compendium* (New York 1990), edited by Augustine Hope and Margaret Walch, *Designing with colour* (Cincinnati 1991), edited by Susan Berry and Judy Martin, *Colour for architecture today* (Abingdon 2009), edited by Tom Porter and Byron Mikellides, *Languages of colour* (Lewes 2012), edited by Alexandra Loske, and *Colour design* (Cambridge 2012 and Amsterdam 2017), edited by Janet Best, contributing chapters on the history of colour in art, science. He has contributed some 40 minor articles to journals including *Artists Newsletter* (1982-1984), *The Artist* (1985 and 1989), *Color Research and Application* (1987 and 2002), *Journal of Art and Design Education* (1988), *Artists and Illustrators* (1993-1994), *Journal of Photographic Science* (1994), *The Colour Group Newsletter* (1988-2008), *Journal of the Society of Dyers and Colourists* (1995 and 2000), *The Jackdaw* (2008 and 2015-2018), and *Interalia Magazine* (2015).

As a part-time and visiting lecturer, 1978-2018, primarily on colour theory in art, design, science and fashion, and also on art history, he has presented over 2,000 lectures at over 200 institutions worldwide, including 44 colleges and universities in London and others throughout the UK. In Ohio (1986-1997), at Akron University and Kent State University, he developed and taught practical colour courses that were extended and modified throughout the 1990s. In various other short tours abroad, he lectured at 26 other colleges and universities in the USA and Canada, and 21 during three visits to Australia and New Zealand.

## Renaissance colour symbolism

### Roy Osborne

Artist, author and educator, London, England  
art.school@virgin.net

#### ABSTRACT

Between 1495 and 1595, a unique series of books was published in France and northern Italy on the subject of colour symbolism, or 'colour signification'. The first was written by the Sicily Herald and the last by Antonio Calli. They all relate to colour in dress, and extend and promote ancient and medieval beliefs that colour was a divine manifestation that could possess profound meaning and inspirational power. Annotated translations of the two most influential books, by Gilles Corrozet and Fulvio Pellegrino Morato, were published by the author in 2012 and 2015. By combining and contrasting contemporary symbolic meanings with those from classical Greece and Rome, together with Andrea Alciato and others, they contributed to a mid-century craze for emblematic poetry and prose, later amplified by Coronato Occolti and Giovanni de' Rinaldi, and especially Giovanni Paolo Lomazzo, whose treatise of 1584 was studied widely by artists and theorists.

**Keywords:** colour, symbolism, history, Renaissance, literature

#### INTRODUCTION

In the seventh volume of his *Histoire de France* (1855), Jules Michelet introduced the term 'Renaissance' to refer to the revival of arts and letters occurring between about 1400 and 1600 and influenced by new enthusiasm for ancient Greek and Roman models. For Michelet, the name encapsulated a cultural shift that, in Western Europe, appeared to move away from the arts and aspirations of the previous, Gothic age. Apart from renewed study of classical architecture, sculpture, literature and philosophy, it was characterised by the questioning of established doctrines and a new appreciation of individual opinion —a neo-Platonic ethic the poet Ludovico Ariosto called *humanismo*. Giorgio Vasari had written about the 'rebirth' (*rinascenza*) of interest in ancient Mediterranean culture, accelerated by Greek refugees importing precious manuscripts to Italy after the fall of Constantinople to the Ottomans in 1453. To the incomers, however, the notion of a 'rebirth' was curious, as the evolution of their own Byzantine culture had remained relatively continuous since 27 BC.

## RENAISSANCE PUBLICATIONS ON COLOUR SYMBOLISM

In chronological order, the most important early books on colour signification were those written by Jean Courtois (1495), Gilles Corrozet (1527), Antonio Telesio (Thylesius, 1528), Fulvio Pellegrino Morato (1535), Lodovico Dolce (1565), Coronato Occolti (1568), Giovanni de' Rinaldi (1584), Giovanni Paolo Lomazzo (1584) and Antonio Calli (1595). The first of them was *Le blason de toutes armes et éscutz*, written about 1420, and printed in Paris by Pierre Le Caron. Its title (Figure 1), in blackletter type, reads, 'the blason all arms and shields Most necessary, useful and profitable to all nobles, lords and preceptors in order to blazon them tabulated in seven sorts of ways.'

Not a great deal is known about its author, Jean Courtois, but a small portrait of him (Figure 2) survives. He was born about 1375, lived most of his life in Mons in Hainaut, and died in 1436. In his introduction, Courtois proclaims himself as 'Sicily Herald to the most-mighty King Alfonso of Aragon, Sicily, Valencia, Majorca, Corsica and Sardinia.' It seems probable however that he received his title from Maria of Enghien, after her marriage to King Ladislaus of Naples in 1407, when she assumed the title queen of Sicily, until Alfonso established his own kingship of the island in 1420. This appears to be what is depicted in the painting, where Courtois rejects Maria's shield (with his left hand) while showing off his new tabard, bearing the quartered arms of Aragon and Sicily.



Figure 1: The printed title of *Le Blason de toutes armes et éscutz*.



Figure 2: Jean Courtois, Sicille hérault.

The verb 'to blazon' (*blasonner* in French) meant to paint a shield with armorial bearings, or to write a verbal description of it; and a duty of the herald was to choose divisions (ordinaries) in the shield and the colours (tinctures) and forms (charges) painted on it, ensuring that no two blazons were the same. By the 1300s, the heraldic devices, and the terms used to blazon them, had been standardised. The principal tinctures consist of the precious metals gold (or) and silver (argent), augmented by red (gules), blue (azure), green (vert), black (sable), and purple (purpure), in that order. In heraldic language, Maria's arms are described as 'gyronny of ten, argent and sable crusilly or,' and Alfonso's as 'party per saltire, in chief and base or, four pallets gules, in dexter and sinister argent, an eagle sable.' In the tables illustrated by Courtois the tinctures are applied respectively for example to the seven worldly virtues (wealth, purity, eminence, loyalty, happiness, modesty and abundance of goods), the seven gemstones (topaz, pearl, ruby, sapphire, emerald, diamond and amethyst), the seven metals (gold, silver, iron, tin, lead, copper and mercury), the seven planets (the Sun, Moon, Mars, Jupiter, Saturn, Venus and Mercury) and the seven ages of man, which, according to Courtois, 'one is not accustomed to have seen before.'

'To blazon' also meant to evaluate the good or bad qualities of a person, hence another duty of the herald was to devise arms that appropriately expressed the virtues of whoever was chosen (by a



monarch or prince) as worthy to bear them, taking into account such factors as ancestry, tutelage, merit, and valour in combat. Virtue (from the Latin *virtus*) is a key word, and variously meant worth, courage, power, goodness, talent, gallantry and moral aspiration. Though one may think of ‘colour psychology’ as a twentieth-century phenomenon, what Courtois treatise confirms is that the relationship between colours and the perceived character or demeanour of a person was well established in Europe at least six centuries ago. There was a widespread belief that the God of the Bible had not only created everything in the universe but had infused it with symbolism and profound significance, which it was up to human beings to ascertain. Colours were believed to be able to boost boldness and morale, and to afford protection from harm to persons wearing them. They were rarely merely decorative in the way they are often considered now.

In 1527, the Parisian publisher and bookseller Pierre Le Brodeur appears to have given a copy of *Le Blason de toutes armes* to his grandson, perhaps with the suggestion that he make a more popular version of it. The author of the resulting publication, ‘The Blason of Colours in Arms, Liveries and Devices’ (*Le blason des couleurs en armes, livrées et devises*), was also given as ‘Sicille hérault’, and it is not until one reaches the acrostic poem (below), at end of the text, that one finds that the first letter of each line reads ‘CARROSET’, revealing its actual compiler as Le Brodeur’s grandson, Gilles Corrozet (1510-1568). Though he did not attend university, Corrozet was to become the author over 30 more works, a successful publisher and a translator of ancient texts. He is perhaps best known for inventing the guidebook as we know it —a portable volume containing maps, pictures and descriptions, as exemplified by his first collaboration (in 1532) with the printer Denis Janot, ‘The Pick of the Antiquities of the Noble and Glorious Town and City of Paris’ (*La fleur des antiquitez de la noble et triumpante ville et citie de Paris*). It became an instant best-seller.

Let’s consider the blazon of colours  
 In which there is deep significance.  
 Let’s remember all joys, sorrows,  
 Revere God, in whom I have my trust.  
 Forget fallacy, therefore, incredibility.  
 One must take His colours that are most beautiful  
 And consign the ugliest to oblivion,  
 Striving to reach the eternal abodes.

*Considerons le blason des couleurs  
 Auquel y a belle signifiante.  
 Rememorons toutes joyes, douleurs,  
 Reverons Dieu, en qui j’ay ma fiance.  
 Oublions donc, fallace, outrecuydance.  
 Ses couleurs fault prendre qui sont plus belles  
 Et les plus laydes remettre en oubliance,  
 Tendrant aller aux maisons eternelles.*

In *Le blason des couleurs en armes*, apart from extending Courtois’ paragraphs on the tinctures, and deleting his passages on heraldic charges, Corrozet’s most significant contribution is the addition of a 10,000-word treatise ‘On Colours in General and in Particular’ (*Du blason des couleurs en général et en espécial*). Prominent among his older references are Pliny’s ‘Natural History’ (*Historia naturalis*) and Bartholomaeus Anglicus ‘On the Properties of Things’ (*De proprietatibus rerum*). In selecting his own colour categories, Corrozet abandons the tinctures and selects instead the seven colours of Aristotle’s colour scale, translated by Bartholomaeus (from *De sensu et sensibilibus*) as *albus* (white), *glaucus* (blue-grey), *citrinus* (yellow), *rubeus* (red), *purpureus* (purple), *viride* (green), *niger* (black).

Adhering to Jean Corbechon’s French translation (*Des propriétés des choses*, 1372), republished by Le Brodeur in 1525, Corrozet replaces *glaucus* with *palle* (pale pink or pallid), and gives his initial sequence as *blanc, palle, jaune, rouge, vert, pourpre* and *noir*. Wanting a fuller range, he then adds four more colours of his own —blue, carnation, violet and grey— before offering significations for all eleven in turn. These colours are allotted moral or virtuous meanings in relation to clothing (as summarised in Table 1), depending on whether they are worn by men, women or children, or in

various liveries or occupational dress, with the last one divided into light grey and dark grey. Corrozet later offers single meanings for pairs and triplets of colours, and even several for colour quadruplets, starting with yellow, violet, white and blue, which together signify ‘amorous loyalty, enjoyment in one’s loves’ (*loyauté amoureuse, jouissance de ses amours*).

white	pallid	yellow	red	green	purple
chastity	mistrust	wisdom	wrath	youth	jurisdiction
virginity	deception	wealth	haste	happiness	domination
humility	treason	joy	boldness	love	abundance
honesty	cunning	eminence	prowess	perpetuity	fortune
purity	fear	liberality	charity	gaiety	royalty
innocence	treason	jealousy	courage	delight	triumph
black	blue	carnation	violet	dark grey	light grey
constancy	jealousy	health	friendship	hope	barrenness
sorrow	gracefulness	eminence	loyalty	patience	poverty
modesty	renown	love	recognition	comfort	enmity
penitence	discretion	good life	kindness	discretion	despair
magnanimity	knowledge	prudence	courtesy	sorrow	toil
discretion	courtesy	assurance	perseverance	sadness	perfection

Table 1: The principal symbolism of Corrozet’s eleven basic colours.

The origin of most of Corrozet’s colour associations is unknown. Some may be from folklore, and others of his own invention. Though many are probably contemporary, his description of how a novice knight is invested resemble lines 140-200 of an anonymous thirteenth-century poem, ‘The Ordination of Knighthood’ (*L’ordène de chevalerie*), as follows: ‘Amongst the ceremonies that are done then, he is invested in white linen drapes which give one to expect the true cleanliness and purity of body that the knight must have. Next he is dressed in a vermilion cloak, which signifies the blood that the knight may have to shed in order to serve God, and exalt the sacred Law and defend the Church. Next he puts on brown silk stockings; this signifies that we are composed of earth and to it we must return, and think often of death. Now he is correctly dressed and is girded with a white belt. This white belt gives one to expect chastity of the body from the knight. Set on his head too is a white coif which signifies that the Christian knight must direct his principal thoughts and attentions to serve God, in order to render his soul clean and free from all sin.’

The year after the publication of Corrozet’s *Blason*, the Calabrian poet and scholar Antonio Telesio (1482-1534) published his ‘Booklet on Colours’ (*Libellus de coloribus*) in Venice. According to his biographer, Francesco Danièle (1762), we learn that, as a student in Cosenza, ‘he made such progress towards the shrine of the Muses that he surpassed those older than himself, as well as far outstripping his contemporaries.’ Telesio later taught Latin grammar and poetry in Milan, moving on to Rome in 1517, owing to the threat of invasion by Imperial troops, only to be caught up in the devastating Sack of Rome in 1527, after which he left for Venice, where he soon secured employment teaching the Scribes of the Republic.

Telesio’s 4,000-word booklet presents a prose dictionary of some 135 Latin colour terms, almost half of which are from Greek originals. It also included examples of cultural colour symbolism. Unlike Corrozet, the sources of his colour significations are mostly identifiable, and derived from the works of such writers as Aristotle, Terence, Varro, Cicero, Virgil, Horace, Ovid, Quintilian and Pliny. His principal colours are grouped under a set of 12 headings, integrating a sequence of seven hues:

*cæruleus* (blue), *cæsius* (blue-grey), *ater* (black), *albus* (white), *pullus* (brown), *ferrugineus* (orange), *rufus* (ginger), *ruber* (red), *roseus* (pink), *Puniceus* (purple), *fulvus* (yellow) and *viridis* (green). This notably departed from the convention established by Aristotle of arranging colours on a scale from dark to light. It may be interesting too that, if *ferrugineus* and *rufus* are combined as orange, Telesio's chapter headings correspond (more closely than Corrozet's) with the eleven so-called 'basic colour terms' established by Brent Berlin and Paul Kay in 1969 —namely, blue, grey, black, white, brown, orange, red, pink, purple, yellow and green.

Chapter 1 of the *Libellus* brings together various Latin terms for blue, Telesio remarking that, 'if Nature did not take exceptional pleasure in it, she would never have bestowed it upon the home of the gods, which, within its encircling embrace, so joyfully encompasses the universe.' He further notes, 'it was the custom to wrap Homer's *Odyssey*, 'which tells of the sea-wanderings of Ulysses', with blue (*cæruleus*), whereas Homer's *Iliad*, 'owing to the slaughter spoken of therein', is wrapped in blood-red (*sanguineus*).' In chapter 2, Telesio derives the term *cæsius* from the verb 'to cut' or 'to slay', observing that it was applied 'to eyes that were horrendous to look upon', meaning cold and grey, like those of lions, but also of Cataline, whose cutting glance, according to Cicero (*Catilinam*, 3.18), 'marks each one of us for slaughter.'

In ancient Rome, white was generally a festive colour, worn on joyous occasions, as during the April festival of Cerealia, dedicated to the grain goddess Ceres. Of his two principal blacks, matt-black or atrous (*ater*) is a 'horrid' colour, 'suited to mourners', Telesio noting that 'black days' (*atra dies*) 'were marked on the calendar with charcoal, whereas joyful days were marked with chalk.' By comparison, deep, glossy black, or nigrus (*niger*), 'is sometimes charming and attractive, as human eyes often are.' In chapter 5, *pullus*, the dark colour of earth and raw wool, was also deemed appropriate for wearing at funerals. Orange (*ferrugineus*), the colour of 'iron that has rusted for some time', might be considered sad too, as when the sky turned this colour after the death of Julius Cæsar, the Sun hiding its 'radiant face,... so that even the Sun might be seen to lament the death of such a great man.' Among the yellows, 'brightest of all shines fulvous (*fulvus*)', similar to the weld-yellow (*luteus*) employed to dye the *luteum* (or *flammeum*), a large shawl worn joyfully by brides on their wedding day.

The most influential sixteenth-century publication on symbolism in general was the *Emblematum liber*, by the Milanese jurist Andrea Alciato (1492-1550). It was first published (unofficially) in Augsburg in 1531 and then in Paris in 1534. As with Telesio, Alciato was keenly interested in the literary legacy of antiquity, which he applied primary to civil law, but also to his own Latin verses. His illustrated collection of moralising poems or fables created a new and immensely popular genre that was plagiarised by many, including Corrozet, who published his own anthology, the *Hécatomgraphie*, in 1540. Alciato's 'Emblem Book' included only one colour poem (below), part of a longer passage on the dyeing of fabrics. It offers a range of apt meanings for those who dress in drab brown (*pullus*), pure white (*candidus*), green (*viridis*), yellow (*flavus*), deep red (*ruber*), sky-blue (*cæruleus*), light brown (*gilvus*), red (*burrhus*), yellow (*fulvus*) or blue-violet (*ianthinus*).

The sign of sadness is the drab colour: we all  
Wear this when we venerate the tomb.  
But a white robe for honest souls and pure minds:  
Hence holy men favour flax and linen.  
Green gives us hope. One speaks of hope  
Being green, how often it dwindles to nothing.  
Yellow is the lustful colour, and suits lovers

*Index mæstitiæ est pullus color: utimur omnes  
Hoc habitu, tumulis cum damus inferias.  
At sinceri animi, et mentis stola candida puræ:  
Hinc sindon sacris linea grata viris.  
Nos sperare docet viridis. Spes dicitur esse  
In viridi, quoties irrita retro cadit.  
Est cupidis flavus color, est et amantibus aptus,*

And whores, and those whose hope is assured.  
 But let red adorn the armed rider's cloak;  
 And indicate shame in the blushing boy.  
 Blue is for the mariners and soothsayers  
 Who reverently scour the awesome skies.  
 Cheap woollens are coarse, dun and reddish,  
 Like the capes of those with wooden-shod feet.  
 Those whom vast cares or jealous love haunts,  
 Believe clothing of yellow will shelter them well.  
 Whoever wears violet is content with his lot,  
 As he wearily bears what the fates have to plot.  
 Just as various colours are created by nature,  
 So one pleases one, but another another.

*Et scortis, et queis spes sua certa fuit.  
 At ruber armatos equites exornet amictus;  
 Indicet et pueros erubuisse pudor.  
 Cæruleus nautas, et qui cælestia vates  
 Attoniti nimia religione petunt.  
 Vilia sunt gilvis nativaque vellera burrhis,  
 Qualia lignipedes stragula habere solent.  
 Quem curæ ingentes cruciant, vel zelus amoris,  
 Creditur hic fulva non male veste tegi.  
 Quisquis sorte sua contentus, ianthina gestet,  
 Fortunæ æquanimis tædia quique ferat.  
 Ut varia est natura coloribus in gignendis,  
 Sic aliis aliud: sed sua cuique placent.*

The most influential sixteenth-century writer specifically on colour symbolism was the Mantuan scholar and lexicographer, Fulvio Pellegrino Morato (c. 1483-1548). In 1532 he had been exiled from Ferrara, for reasons unclear. Three years later, while based in Vicenza, his 'On the Signification of Colours' (*Del significato de' colori*) was published in Venice. Probably owing to the influence of the diplomat Celio Calcagnini, Morato was allowed to return to Ferrara four years later, and thereafter taught the two youngest sons of the late Alfonso I d'Este and Laura Dianti. He had previously taught the second and third sons of Alfonso and Lucrezia Borgia.

A reason why few publications, other than Corrozet's, recorded contemporary colour connotations may be because they were so familiar that few thought it necessary to write them down. One might propose that the more homogeneous the society the more consistent is the agreement between colours and their meanings. On the other hand, as with Morato, it is often on contact with different sets of connotations that comparisons between them are examined and discussed. Morato's remarkable, if inconsistent, 12,000-word compendium draws on over 50 literary sources, from Homer, Hesiod and the Bible, through Cicero, Horace, Ovid, Plutarch and Virgil (his beloved 'Mantuan shepherd'), to later Italian authors, including Petrarch and Serafino. His prime intention appeared to be to furnish his generation with superior codes of colour meanings based on antique models. With respect to Renaissance veneration for ancient arts, literature and philosophy, Morato appears to have made the assumption that ancient colour symbolism must be worthier too.

The colour green, reduced to nil  
 It means; red offers meagre courage,  
 Black has its will full of madness,  
 White expends one's passion and desires.  
 Yellow offers hope reborn,  
 Tawny conceals wise wiliness within,  
 Purple scorns death for love,  
 Whoever wears grey dupes people.  
 Carnation offers amorous delight,  
 Mottled shows bizarreness of mind,  
 Blue lifts thought high up aloft.  
 Whoever has faith and power dresses in gold,  
 Silver means to be deceived,  
 With yellow green, scant hope remains.

Il color verde ridotto a niente  
 Dimostra; il rosso ha poca sicurezza,  
 Il nero ha'l suo voler pien di matezza,  
 Il bianco ha suo appetito, e voglie spente.  
 Il giallo ha la speranza rinascente,  
 Copre il taneo in se saggia sciochezza,  
 Il morel morte per Amor disprezza,  
 Chi veste berettin, gabba la gente.  
 Amorosio piacer ha l'incarnato,  
 Il mischio mostra bizzaria di testa,  
 Il torchino ha il pensier molto elevato.  
 Chi ha fede, e signoria d'oro si vesta,  
 L'argentino dimostra esser gabbato,  
 Al verde gial poca speranza resta.

The *Significato* begins with a 14-line sonnet (above) in the style of Petrarch. This is followed by 14 chapters of different lengths, justifying each of its meanings in turn, and presented in the order, dark green (*verde*), red (*rosso*), black (*nero*), white (*bianco*), yellow (*giallo*), tawny (*taneo*), red-purple (*morello*), grey (*berettino*), rosy (*incarnato*), mottled (*mischio*), blue (*torchino*), gold (*oro*), silver (*argentino*) and yellow-green (*verde giallo*). For the Church, green symbolised faith, but in Morato's first chapter it signifies hopelessness and despair. He calls upon Petrarch to confirm this, 'saying that his hope had reached the green,' in his sonnet, 'Already the amorous star was blazing' (*Già fiammeggiava l'amorosa stella*), 'showing himself to be beyond all hope, and that the things once hoped for have come to nothing.' More optimistically, Morato also notes that, in ancient tombs, 'they find rings in which emeralds are set', associating evergreen gems with everlasting life, and adding that 'nothing is ever so final that no hope remains at all, and so plants and leaves gladden the eyes in spring.'

Red is a more consistently uplifting colour, useful for boosting confidence; but while it usually implies bravery, for Morato red implies cowardice, as anyone naturally brave would not need to wear it to compensate for lack of courage. In Ovid's *Fasti* (2.103), for example, the timorous Arion wraps himself in a red cloak to summon up courage to leap from the pirate ship. Morato notes further, on the authority of Homer and Virgil, that biers on which valiant soldiers lay are draped in this colour in order to instil courage in their fellow warriors. Other associations with red include sacrifice, martyrdom, cruelty, tyranny and apprehension. With black, though Morato concedes that it can signify stability and constancy, 'inasmuch as every other one except it can be altered,' he relentlessly lists its many negative aspects (as those by Plato and Cicero), which include deceit, cruelty, villainy, obstinacy, misfortune and vile intent. Even when the Virgin Mary endures the death of her Son, it is not black she wears but blue.

Whereas green reaches the limit, white leads to extinction. Corpses are wrapped in bleached white shrouds, and 'there is no one who doesn't know that to be reduced to ashes means to be destroyed completely.' Of all Morato's colours, white offers the widest range of significations. It can either hide or expose, as when Medea conceals her deceit by whitewashing her hands, or when senatorial candidates reveal their 'chalked ambition' by rubbing chalk into their togas to enhance their whiteness. White feet indicate servitude, and white (or blank, *bianco*) shields indicate inexperience, as when soldier recruits wore white 'as a sign that they had not yet stained their hands honourably with the blood of the enemy.' Alternatively, 'one observes white to be a sign of happiness, as when, in sacrifices to Ceres, one sacrifices in white clothing,' just as the Church assumes the Alb 'after the victory of Christ's Resurrection.'

The sonnet's fifth colour, deep yellow, is consistently optimistic, as when 'Aurora cloaks herself in this colour when she opens the doors of day.' Such a colour should be worn 'when we newly start to hope for something once lost,' just as whoever might dare 'to attempt to undertake perilous and risky tasks, without ever conceding defeat, should rightly adopt this dye for his emblem.' Morato justifies the meaning of tawny brown with reference to the cunning of lions and hares that conceal themselves on earth of this colour, or in stony places. The wearing of purple can signify resoluteness, magnanimity and eminence, and hence befits counsellors, scholars, bishops and patriarchs. Ashen grey is deemed appropriate for those who act slyly or in a deceptive manner; whereas, with pink, anyone who has 'won the ultimate reward from his mistress, will rightly make this emblem prominent.' While few courtiers might display such a colour, it could be seen in Ferrara in such pictures as Titians' *Bacchus and Ariadne* (1524), installed in Duke Alfonso's *Camerino*, where the leaping wine-god's cloak is carnation, while the virtuous Ariadne wears blue over white.

The tenth line refers not to one hue but an assorted mixture (*il mischio*), and Morato has little else to add other than it implies the confusion of someone who ‘mingles together contrary things within himself.’ The next colour, blue, predictably inspires celestial thoughts, so that whoever aspires to great things ‘should rightly adorn himself in such clothing’ and, according to Plato, direct his mind ‘to high and divine things.’ Gold is for those with ‘faith and mastery’, and perhaps because its eminence is so evident, little else is said. One biblical endorsement, from *The First Epistle of Peter* (1:7), is cited, though Alexander Cruden’s *Concordance* lists almost 300 other references to this the most prized of all metals. Silver is of lesser value, and owing perhaps to the illusory nature of its polished surface, Morato suggests that anyone wanting to wear it is deluded. The final colour, yellow-green, implies unripeness, immaturity, caution, uncertainty and faltering hope. Hence, ‘when Lombard peasants want to say, only God knows what will be, and lack the courage to hope, they say, the crops are not yet fully green.’

A second, slightly revised edition of *Del significato de’ colori* was issued in 1543, augmented with an appendix on the signification of bouquets (*Il significato de mazzoli*), consisting of meanings for almost 200 animals, birds, flowers and plants. The material adds little about colour, and implies that whatever message such items may overtly or covertly convey would either raise or lower an admirer’s hopes.

### THE INFLUENCE OF CORROZET AND MORATO ON LATER WRITINGS

After Morato, a period of 30 years elapses before, in 1565, the prolific Venetian author and translator, Lodovico Dolce (1508-68), published a new compilation of colour texts entitled ‘Dialogue, in Which Is Discussed the Quality, Diversity, and Attributes of Colours’ (*Dialogo, nel quale si ragiona delle qualità, diversità, e proprietà dei colori*). Within it, he includes a full Italian translation of Telesio’s *Libellus de coloribus*, restyled as a conversation, together with Morato’s chapters on green, red, black, white, grey, blue, gold, silver and yellow-green, omitting those on yellow, tawny, purple, carnation and mottled. Dolce was a close friend of Titian, Venice’s greatest painter, and it seems likely that he at least perused it, if not studied, its chapters.

The next book on the subject was Coronato Occolti’s ‘Treatise on Colours’ (*Trattato de’ colori*), published in Parma in 1568, and influenced by both Corrozet and Morato. Occolti’s compilation re-uses Morato’s format of a poem (extended to 40 lines) followed by chapters on each individual colour, presented in the sequence, *bianco* (white), *oro* (gold), *argento* (silver), *berettino* (grey), *rosso* (red), *turchino* (blue), *verde* (green), *incarnato* (carnation or roseate), *giallo* (yellow), *morello* (red-purple), *taneto* (tanned or tawny), *mischio* (mottled), *vermiglio* (vermilion), *atro* (black), *pallido* (pallid), *zallolino* (fawn or dull yellow), *cinerio* (ashen-grey), *rosasecca* (dull purple), *cesio* (blue-grey) and *violetto* (violet). The last six colours (following Morato’s 14) indicate that Occolti (whose name may be a pseudonym) also incorporated blazons originally offered by Corrozet. This is most apparent in his lists of livery colours (*De’ colori in livrea*), before he concludes with an extended list of gifts or bouquets.

Three more relevant books were published in 1584. The one dealing most centrally with colour symbolism was Giovanni de’ Rinaldi’s ‘The Most-magnificent Show’ (*Il mostruosissimo mostro*), referring to nature’s spectacular display of colours and flowers. Again, as with Morato’s 1543 edition, the first half of Rinaldi’s compilation starts with a colour sonnet, and in its latter half expands his meanings for flowers, fruits, herbs, leaves and feathers. His principal colours are the same as Morato’s but presented in a different order, introduced before Rinaldi (who died in 1599) offers

revised explanations for each one in turn. The second publication, offering scattered references to colour symbolism, was 'The Repose' (*Il riposo*) by the Florentine writer Raffaello Borghini, and named after the villa in which its fictive dialogue takes place. At 650 pages, it competes with the 700 pages of the superior 'Treatise on the Arts of Painting, Sculpture, and Architecture' (*Trattato dell' arte della pittura, scoltura, et architettura*), compiled by Giovanni Paolo Lomazzo (1538-1592).

Lomazzo was a successful practising artist in Milan until his eyesight began to fail, after which he turned to teaching and writing. He was entirely blind by 1572. In chapter 58, one of eight on colour in Book 6, Lomazzo names Telesio and Morato among his sources as well as 'Sicillo Araldo' (Sicily Herald), from which we infer that the version of Corrozet's *Blason des couleurs* used by both Occolti and Lomazzo was the Italian translation made by Giuseppe Dondi dall'Orologio, published in Venice in 1565 and entitled *Trattato dei colori nelle arme, nelle livree, et nelle devise*. Of Lomazzo's seven sections, the shortest, Book 3, is wholly on colour, its first chapter (on the virtue of colour) stating that, 'Neither yet does it only express the outward forms of things, but also discovers certain inward passions, painting as it were laying before our eyes the affections of the mind, with their effects.' Through a series of seven chapters (summarised in Table 2), Lomazzo offers significations for black (*nero*), white (*bianco*), red (*rosso*), purple (*pavonazzo*), yellow (*giallo*), green (*verde*) and blue (*turchino*). On closer inspection, one finds that all rely heavily on passages from Corrozet or Morato. Importantly, this shows that books on the subject were consulted and applied by artists. Inadvertently, they became the century's two most influential sources of colour signification, though few art historians have acknowledged their contribution to contemporary or later theories of colour.

Chapter 12	Chapter 13	Chapter 14	Chapter 15	Chapter 16	Chapter 17	Chapter 18
black	white	red	purple	yellow	green	blue
nero	bianco	rosso	pavonazzo	giallo	verde	turchino
planet god	planet god	planet god	planet god	planet god	planet god	planet god
Saturn	Moon	Mars	Mercury	Sun Apollo	Venus	Jupiter
Saturno	Luna	Marte	Mercurio	Sole Apollo	Venere	Giove
Winter	Autumn	Summer	regality	dawn	Spring	heaven
verno	autunno	estate	sovranità	aurora	primavera	cielo
prudence	hope	charity	temperance	faith	fortitude	justice
prudenza	speranza	carità	temperanza	fede	fortezza	giustitia
earth	water	fire	coldness	grace	perpetuity	air
terra	acqua	fuoco	freddezza	grazia	perpetuità	aere
melancholy	phlegm	blood	recognition	cholera	juvenility	loftiness
melanconico	flemma	sangue	recognitione	collera	giovinezza	elevazione
probity	purity	magnanimity	loyalty	superiority	contentment	spirituality
probità	purità	magnanimità	lealtà	signoria	piacere	spiritualità
stability	wisdom	courage	fierceness	wealth	hope	devotion
stabilità	sapienza	spirito	fierrezza	ricchezza	speranza	divozione
conviction	innocence	valour	courage	nobility	enjoyment	aspiration
decisione	innocenza	valore	spirito	nobilità	giocondità	aspirazione
dignity	simplicity	majesty	foolishness	sweetness	kindness	eminence
dignità	semplicità	maestà	imprudenza	dolcezza	bontà	altezza
misfortune	elation	boldness	ardour	joy	recreation	suavity
infelicitade	superbia	arditezza	ardore	allegrezza	ricreazione	soavità
sadness	scorn	revenge	devotion	delight	despair	piety
tristezza	biasmo	vendetta	divozione	diletto	disperamento	pietà
mourning	servitude	martyrdom	abundance	authority	finality	decorum
cordoglio	servitù	martirio	abbondanza	autorità	estremità	decoro

Table 2: Colour significations in Lomazzo's Books 3 and 6.

Whereas, until about mid-century, scholars generally advised artists on the iconography of their pictures, by the 1580s, they now needed to do this for themselves, assisted by such texts as Borghini's and Lomazzo's. Several of the latter's chapters in Book 6 (on general art practice) focus on associations between colour and human attributes. Hence, in chapter 8, on 'what sort of people particularly suit the colours,' and in order to 'understand the reasons for assigning the colours according to the types of figures represented,' Lomazzo advises that dark clothing is appropriate for philosophers, the poor and the solemn, for example, whereas 'the roseate colours, light greens, and yellowish ones,' are more apt for 'nymphs, youths and harlots.' Book 6, chapter 58, relies quite heavily on Corrozet's *Blason*, and even presents its colour meanings in heraldic order of priority, starting with gold and yellow, and silver and white. The chapter concludes with Lomazzo restating why he thought artists needed to learn such significations, this being 'so that one may thereby acquire an understanding of these colours, from which one then gains judgement in deploying and applying them appropriately in clothes to kings, priests, and eminent people, according to the status of each one and to diverse national customs.'

While very few of his colour associations were original, Lomazzo is perhaps the earliest artist to write extensively on the theory of the four humours, a subject he introduces near the start of his first chapter. The theory of the humours (or principal bodily fluids), was first advanced in Hippocrates' 'On the Nature of Man' (*Peri physeos anthropu*), about 400 BC. They customarily consisted of black bile (from the gall bladder), white phlegm (from the lungs), red blood (from the liver), and yellow bile (from the spleen). Dolce had published a translation of Claudius Galen's derived humoral doctrine in his *Oratione di Galeno* in 1548. It is possible that this encouraged Titian to apply such theories to his paintings, rather like physicians of the time would diagnose patients partly according to their facial complexion. This indeed may be what Lomazzo was alluding to when he observes (in Book 1, chapter 1) that, having applied suitable colours to a portrait, 'whosoever beholds it may be able to say ... it is the picture of a melancholic, phlegmatic, sanguine, or choleric person, of one in love, or in fear, of a bashful young man.'

## DECLINE IN THE SIGNIFICANCE OF COLOUR SYMBOLISM

Exactly a century after Courtois' *Blason de toutes armes* was printed in Paris, Antonio Calli published his 'Discourse on Colours' (*Discorso de' colori*) in Padua. It presents a 5,000-word essay on colour signification followed by five colour poems, including those by Morato, Occulti, Rinaldi and Eustachio Celebrino (1525). It was to become the last original compendium of its kind, with no other book wholly on colour symbolism appearing again until 1837, with the exception of Carlo Piazza's 1682 edition of 'The Sacred Rainbow Revealed in the Colours of Ecclesiastical Garments' (*L'iride sagra spiegata nei colori degli abiti ecclesiastici*).

What one seemed to witness, at the end of the 1500s, was the diminution, if not rejection, of the centuries-old belief that colour was infused by God with superstitious or mystical powers, beginning in *Genesis*, chapter 1, when 'every green herb' was manifested for animals to eat. The major Italian books on colour symbolism had all been published in the northern cities of Venice, Pavia, Ferrara, Milan or Padua, in or near localities where the long-established ducal-court system was now in decline. In 1598, for example, Ferrara's palaces were plundered by agents of Pope Clement VIII, after Duke Alfonso II died childless. Though Naples and Rome were important cultural centres, it was in the northern courts and *palazzetti* that the enduring model for European arts and letters was



nurtured, with their refined cultivation and appreciation of courtly behaviour, dress and decor, literature, music, dance, pastimes and the visual arts.

So what happened? Regarding dress and decor, the flamboyant colours popular during the first half of the sixteenth century —during a period of so-called ‘Mannerism’ in the arts— later fell out of fashion primarily owing to the rise of the Counter-Reformation, the malicious response by Catholic authorities to the rapid expansion of Protestantism, aided by the distribution of cheaply printed books. Relatively little resistance to Reformism had been apparent until the accession of Pope Paul III in 1534, who reactivated the Roman Inquisition, presided over by the Dominicans (the Blackfriars) —who superintended the Inquisition between 1216 and 1860 (in Peru)— and reinforced it with black-clad Jesuits dedicated to eliminating all heretical doctrines. In the arts, the reaction was typified in Giovanni Andrea Gilio’s *Dialogo* of 1564. Consequently, the latter half of the century witnessed the pervasive adoption of the puritanical black that had long characterised all forms of fundamentalism, even down to the present time. Colourful clothing had for centuries been associated with individuality, festivity and sensuality, all of which were firmly condemned in the latest upsurge of religious and social conformism.

A second, undoubted reason was the rise of empirical or experimental science. Perhaps, more than anything, this is what brought the Renaissance to a close, while simultaneously propelling Europe into a new, Baroque age. The superstitious and subjective gave way to the rational and objective, and with it went the ancient belief in the magical and efficacious potency of colour. A notable originator in this transition was Bernardino Telesio (1509-1588), who had been tutored by his uncle Antonio between 1517 and 1529, before both returned to Calabria. Bernardino’s anti-Aristotelian treatise, ‘On the Nature of Things According to Their Own Principles’ (*De rerum natura juxta propria principia*) was first published in 1565, six years after the Catholic Church imposed its *Index of Prohibited Books*, to which it was promptly added. His 1570 pamphlet, ‘On the Generation of Colour’ (*De colorum generatione*) offered a not entirely inaccurate explanation of the rainbow, in place of Aristotle’s mistaken theory, and was soon censured too.

The established Church had for centuries been resistant to change, ironically owing in part to its veneration of antique literature, including its esteem of Aristotle, for example, rather than Lucretius. After visiting Oxford University, in 1588, Giordano Bruno observed that, ‘Masters and Bachelors who do not follow Aristotle faithfully, are fined five shillings for each offence.’ In Italy, after the turn of the century, scientific advances were increasingly suppressed, and instead began to flourish in Protestant northern Europe, where for example the English philosopher Francis Bacon acknowledged Bernardino Telesio as ‘the first of modern men’ (*novorum hominum primum*). Had Catholicism been permitted to regain its absolute power, it seems improbable that Baroque science would have advanced as steadily as it did —bearing in mind that the *Index of Prohibited Books* was not abolished until 1966. As chemistry and biology were still largely undeveloped, the new flowering of science was led by optics, including the study of the rainbow. The celestial sign, sent originally by God to Noah after the Flood (*Genesis*, chapter 9), was now perceived less as a divine wonder and more as a physical phenomenon to be analysed and measured with lenses, prisms and protractors.

An age of reason was superseded by an age of enlightenment, and it was not until the dawn of Romanticism that Johann Wolfgang von Goethe, while investigating optics and colour illusions, also turned his attention to the ‘allegorical, symbolic, mystical use of colour.’ He included examples of Renaissance colour literature, including Telesio’s *Libellus de coloribus*, in his ‘Contributions to the history of colour-theory’ (*Materialien zur Geschichte der Farbenlehre*), commenting on its author that, ‘even if we do not always agree with his view, we still feel inclined to follow him, in order to

learn from and with him.’ Goethe briefly revived the theory of the four humours or temperaments, applying it to twelve personality types, defined by their vocations, and not unlike Lomazzo’s associations in Book 6, linking various types of people with their most appropriate colours. In Figure 3, the now-faded, named colours of the predominantly green quarter of Goethe’s *Temperaments-Rose* (c. 1799) are associated with the sanguine humour and ‘bonvivants, lovers and poets,’ the blue quarter with the phlegmatic and ‘teachers, historians and orators,’ the purple quarter with the melancholic and ‘monarchs, scholars and philosophers,’ and the red quarter with the choleric and with ‘despots, heroes and adventurers.’

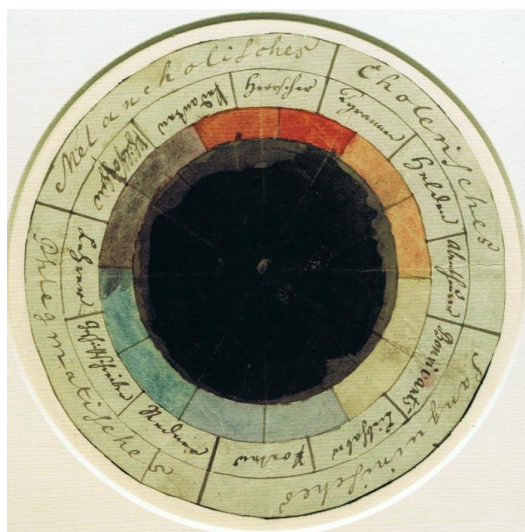

Figure 3: Johann Wolfgang von Goethe’s *Temperamenten-Rose*.

It was not until 1837, almost 250 years after Calli’s booklet, that Frédéric de Portal (1804-1876) published ‘On Symbolic Colours, in Antiquity, the Middle Ages, and Modern Times’ (*Des couleurs symboliques, dans l’antiquité, le moyen âge, et les temps modernes*). Believing the inherent meanings of colours were ancient, Portal groups together associations for each separate colour in a series of well-researched chapters. A revival of interest in Gothic art then inspired Symbolist painters throughout Europe to reintroduce mystical colour and form symbolism in their artworks. Not long afterwards, colour literature began newly to explore the symbolic and therapeutic potential of colour, promulgated in a stream of publications, including those by John Ingram (1870) and Franz Delitzsch (1889) on flower symbolism, and Augustus Pleasonton (1876), Seth Pancoast (1877), Edwin Babbitt (1879), Augustin Charpentier (1888) and Hyppolite Baraduc (1896), on colour therapy.

After the turn of the century, interest in esoteric symbolism was also revived in a number of theosophical publications, starting with *Thought-forms* (1901), by Annie Besant and Charles Leadbeater, which attributed synaesthetic properties to colours, and exerted some influence on early ‘expressionist’ painters. For Impressionist artists, observing colours in the exterior world, it was their *relativity* that mattered, so that the notion of isolating colours in order to interpret their meanings was irrelevant. The Expressionists, on the other hand, pursued such an aim in order to justify including particular colours in their non-naturalistic works of art. Thereafter, the presumed capacity of colours to communicate or diagnose human attributes, emotions and preferences continued to be studied in depth and was channelled perhaps most importantly into differing branches of psychology.

## CONCLUSION

The remarkable, if largely neglected, series of publications on varied meanings for colours, published between 1495 and 1595, invaluable capture and record contemporary and ancient beliefs that colour was a divine gift imbued with palpable power and mystical meaning. Whether in France or northern Italy, the books all were published in cities having courts or palaces with nobles and courtiers able to afford and disport a variety of colourful clothing. Notably, after Calli's *Discorso* of 1595, no original books wholly on colour symbolism were published until Portal's *Des couleurs symboliques* in 1837. This appears to suggest that, after about 1600, previous presumptions about the potency of colour were increasingly depreciated throughout the ensuing Baroque era, most obviously owing to the rise of empirical science, and a novel belief (at that time) that light and colour were physical phenomena, preferably analysed with optical and geometrical instruments. Goethe revived interest in colour connotations early in the 1800s, but it was not until the rise of literary and artistic Symbolist and Expressionist movements, towards the end of the century, that Renaissance notions of colour potency were revived and endorsed widely, after which indicative and diagnostic meanings for colours were most obviously assimilated into the visual arts and aspects of colour therapy and psychology.

Details of all the books cited in this article are listed in the author's *Books on colour 1495-2015: history and bibliography* (2015).

# Art and Design



# Colour and place making; an artist's influence on spatial production

Alex Booker\*, Kine Angelo

Norwegian University of Science and Technology, Faculty of Architecture and Design,  
Department of Architecture and Technology, Trondheim, Norway

\* alex.booker@ntnu.no

## ABSTRACT

The Norwegian painter Harald Sohlberg (1869-1935) had a unique influence in the production of a national iconography of place and identity, producing a body of work that captures the essence of colour and atmosphere that are particular to the interaction of northern light and landscape. We examine how Sohlberg's representation of two colour spaces, the urban and the mountain landscape, have proved instrumental in preservation of an iconic "place" and in the recent production of a new architectural space. These works contribute to the mediation of place that participates in the development of viewing landscape as scenography in the production of regional identity and imagistic moments for the tourist industry. Drawing on sources from heritage research and the authors own observations the question of the authenticity of colour and place in the face of the distorting demands of the spectacular moment is examined.

**Keywords:** colour, place, architecture, art, heritage

## INTRODUCTION

Harald Sohlberg's painting *Street in Røros in winter* (1903) presents a meticulously observed colour, form and topographic rendition of a street in the mountain mining town of Røros. This painting's exhibition in Oslo raised interest and awareness of the "picturesque value" of the remote, and relatively inaccessible site and played an important role in the town's first Heritage Site Designation and Preservation (1924), a process that would eventually lead to a UNESCO listing in 1982 (see Guttormsen and Fageraas 2011). *Winter night in the mountains* (1913) is a neo-romantic symbolist rendition of blue atmosphere of the mountain twilight and is a representation of the sublime "blue hour" that has a particular resonance in Scandinavian life. The special cultural role of this painting in the production of a mythology of place and atmosphere contributed to the area's "iconic" status and thus the ideal placement for a Norwegian Tourist Routes project. This leads to the commissioning of an architectural viewing platform "Sohlberplassen" (2006) by architect Carl-Viggo Hølmebakk.

### **National romanticism in Norway; a short background**

In order to appreciate cultural power of these images it is important to understand the social and political motivations for the production of the national romantic ideal that starts in the 1800s. Norway as a fully independent nation is relatively young (1905). Union with Denmark lasted for 400 years, during which time it was administered from Copenhagen. Union with Sweden in 1814 brought a new constitution that allowed a degree of independence in domestic affairs and defining and constructing "Norwegianess" becomes a tactic for the cultural and political elite in progress towards full independence.

The image of nature, the countries topography, inaccessibility, and the mystic Nordic landscape became one of the strategies used to construct an identity that would unite a widespread and isolated population as "Norwegian" citizens (Žagar 2009). "Mountain ranges and often barely arable land had to be redefined as positive symbols rather than the often bleak and inhospitable tracts that they actually are" (Hult 2003). This period is marked by the collection of folk tales, music, dialects, the cataloguing of regional craft and architectural forms, that provide the material for developing the liberal arts expression of national romanticism in music, literature, architecture and the visual arts in the 1840s.

Painting plays a central role with German trained Norwegian artists such as Grude, Tideman and Dahl turning to motifs of untamed landscape in the tradition of the sublime. The emergence of international tourism in the 1850s also contributes to this image as wealthy English and European tourists began to visit Norway for walking in pursuit of unspoilt vistas, fishing and hunting, this in turn establishes an understanding of nature as cultural and capital value. By the 1880s this process had established the landscape, the quality of northern light, isolated communities and desolate plateaus as ideals and raised them to the level of symbols in literature, music, poetry and art (Žagar 2009).

It is in this iconography of national identity that artists such as Munch and Sohlberg emerge with a more symbolist representation of identity as a question of the individual's existential relation to culture and place.

It is no exaggeration to say that Norwegian nature became so emotionally and ideologically charged in the 1800s that Norwegians have never since been able to see it detached from and untouched by questions of identity and nation. There they found not only personal liberation and artistic redemption; it also aroused national pride. (Witoszek 1998)

### **Sohlberg in Rondane and Røros**

Sohlberg's first visit to Rondane is an experience of the sublime: "This sight was the most magnificent I have ever seen. It was filled with a sublime beauty. An endless sky stretched over the white contours of the Nordic winter. Myriads of stars sparkled. It was like a mass in an enormous cathedral". He will pursue this image in an artistic process that involves repeated visits, working with sketches, paintings and photography. In 1900 Sohlberg moves to Rondane to work on preliminary studies and then moves to the Røros area with his family from 1902 to 1905. Work on the variations of *Winter night in the mountains* will occupy him intermittently for the next 14 years and is completed after his return to Oslo. In Røros he will mainly concentrate on depictions of his immediate surroundings in addition to visiting the Rondane mountains (see Opstad 2014).

### ***Efter snestorm, Lillegaten Røros – Street in Røros in winter***

This is a meticulously observed work, both a drawing and a painting in which every materiality and proportion is rendered with a precision and attention to detail that registers the weathering and surface patina (Figure 1, left). The painting closely matches the material qualities that are discernible in black and white photographs from this date. Given Sohlberg's attention to detail and precision in this and other views of Røros it is justifiable to view the colour he used as closely based on the building's appearance though with slight symbolist exaggeration. This painting was exhibited in Europe, America and Kristiania (Oslo). While Røros was known in Norway as a mining town of importance for copper production, and to historians for its particular architectural typology, it was much less well known to the general public. The exhibition coincides with new tendencies in heritage ideology for a socially oriented identity production in elevating previously overlooked working industrial heritage. The public visibility and popularity of Sohlberg's painting of this row of ordinary houses plays a central role when the Director of the National Antiquarians Office proposes a preservation order in 1924, he does so with reference to this painting (Bye 2008).



Figure 1: Left: *Efter snestorm, Lillegaten Røros*, oil on canvas 60.5 × 90.5 cm, 1903, National Gallery, Oslo. Right: Røros by Google street view, 2010.

This is the first example of a coherent “view” of domestic architecture receiving this kind of attention in Norway and represents a pictorialist impulse to preserve a scenographic narrative of an ordinary street (Figure 1, right). It is probable that, in a time before the development of colour photography, Sohlberg's representation of these buildings in colour is a reason for this. That a substantial number of older structures of greater historical value were only listed at later dates supports this (Andersen and Brønne 2006).

### ***Vinternatt i Rondane - Winter night in the mountains***

This painting, donated to the National Gallery in 1918, is the culmination of 14 years of work on variations and studies in a diversity of media. Unlike *Street in Røros in winter*, it is not an accurate representation from one viewpoint but a construct from multiple viewpoints in which the topography is distorted to generate the affect of grandeur and immensity, this, combined with the blue that seems to radiate an internal light places the work firmly in a symbolist tradition. It is representational of a state of mind in the presence of the sublime rather than the landscape object as the sublime (Figure 2, left).



Figure 2: Left: *Vinternatt i Rondane*, aka *Vinternatt i fjellene* (Bjerke 2018), oil on canvas, 160 × 180.5 cm, 1914, National Gallery, Oslo. Right: Sohlbergsplassen Rondane (2006), architect Carl-Viggo Hølmebakk.

The depiction of the colour of light in the transition from day to night is a central theme in Sohlberg's oeuvre and one of the particularities of the northern latitudes. These phenomena occupy a particular place in the Norwegian imagination as the representation of a numinous quality. The particular position of blue as an evocation of otherness is described by the author Rebbecca Solnit;

...the blue at the far edge of what can be seen, that color of horizons, of remote mountain ranges, of anything far away. The color of that distance is the color of an emotion, the color of solitude and of desire, the color of there seen from here, the color of where you are not. And the color of where you can never go. (Solnit 2006)

That *Winter night in the mountains* was voted Norway's national painting in 1995 over works by Munch or other national romantics testifies to the power of its authentic "aura" (Benjamin 1935) and capacity to act as an icon of both the object represented (mountains) and the colour atmospheric that resonates in mirroring a mental state. In 1993 the Norwegian government granted funding for the national tourist roads project to examine the potential of new tourism development and to improve infrastructure in already well trafficked sites: "...their experiences of the scenery and cultural landscape are intended to be genuine and unique, where the original scenery is embellished with traces of our own time through innovative architecture, art and design" (DETOUR).

Local authorities were invited to propose routes that had potential for development including previously unexploited scenic possibilities. The Norwegian Scenic Route Rondane was one of the 18 routes chosen out of 52 applicants, it runs past the mountains that are represented in Sohlberg's painting. A central aspect of the project is the commissioning of contemporary architecture at key tourist facilities and viewing points. This leads to the design of the architectural viewing platform "Sohlbergsplassen" by architect Carl-Viggo Hølmebakk completed in 2006 (Figure 2, right). This is the only site in Norway the construction of which is directly attributable to a specific artistic representation of a view and it can be argued that the iconic status of Sohlberg's painting is pivotal in the selection of this project.



## DISCUSSION

“Rondane – Along the blue mountains” a drive that offers close encounter with Norwegian nature in the easily accessible borderland between high mountains and ancient cultural landscapes ...offers experiences and inspiration at an easy-going pace” (Norwegian Scenic Routes).

Distraction and concentration form polar opposites... A man who concentrates before a work of art is absorbed by it... In contrast, the distracted mass absorbs the work of art. This is most obvious with regard to buildings. Architecture has always represented the prototype of a work of art the reception of which is consumed... in a state of distraction. (Benjamin 1935)

Seen through the Benjaminian definition of “aura”, Sohlberg’s paintings possess the authenticity of the deeply felt and observed that provide, through their colour and atmosphere, access to an example of a way of seeing what is both a historical condition and a state of being present in place. The paintings act as a gateway to the transcendental apperception of the artist that is made available to the perceptive viewer. That the power of the Røros paintings colour and detailing play a role in the early heritage designation of Røros is clear.

The physical location pictured in Sohlberg painting still exists, but with so many changes made in the past 100 years the current buildings are merely indexical, pointing towards what once was. As all the buildings have been altered and external weatherboarding replaced, it is not possible to ascertain a nominal colour archaeology older than the 1950s. The first colour plan for Røros was made in the 1970s and was in essence an aesthetic response based on the general Norwegian colour tradition that bore little relation to the actual colours used in the 1800s (Andersen and Brønne 2006). The buildings painted by Sohlberg in 1903 had already undergone changes by the time of their listing in 1924 and substantial alteration in the following years. A general formation of scale and cadence is roughly maintained but colour, material, detail, historic form and function are changed. It retains the experience value of recognition and symbolic cultural value, but as an approximation that points us back to what was, the only auratic document of which resides in the artwork. The painting is the true monument, a lens through which we can see the past layered upon the present and visa-versa. What remains is authentic only as a general indication that nevertheless plays an important role in the cultural construction and maintenance of a local identity.

The viewing platform at Sohlbergplassen is an intended monument. It curates a position and view of the landscape made iconic in a painting, the project comes into being due to the numinous blue of the atmosphere and genius loci that Sohlberg catches and that exerts a powerful mythic affect in the Norwegian imagination, however it is unlikely that it would have been commissioned in isolation, as such it is a convenient cultural referent in a project that is based on infrastructural expansion. In geographic peripheries this is a potential driver for the production of attractions that can be invested in for regional benefit by the direction of the touristic gaze: “the less important the spatial barriers, the greater the sensitivity of capital to the variations of place within space, and the greater the incentive for places to be differentiated in ways attractive to capital” (Harvey 1991).

That communication and national branding potential was an integral strategic motivation in the inception is indicated by the exhibition DETOUR documenting the design of tourist roads projects that continues to tour Europe and America generating substantial interest and prestige (see Lysholm 2008). In 2007 Sohlbergplassen was nominated as one of the 12 most important buildings in Norway since 1945 by a jury of architects in the newspaper *Morgenbladet* (2007). “A beautiful and innovative

example of Norwegian contemporary architecture... Despite its simple function and modest size... [it] is undoubtedly a major work in recent Norwegian architecture history" (Jury comment; *Morgenbladet* 2007). In retrospect, this somewhat exaggerated accolade is more attributable to the "national romantic power" of the context than the actual architectural qualities.

That Sohlberg's paintings have been an instrumental factor in the preservation and production of place is clear. His representation of colour in the urban fabric and the atmosphere of landscape is an essential component. We consider that in both cases it is the artists use of colour that is the central active and communicative attribute of the images power and therefore the quality with a very high level of agency in the production of the "place myth" that results in these two sites.

There remains the question of how these monuments are apprehended in relation to their primary source, in truth we cannot see "what" Sohlberg saw, we may grasp some small glimpse through his registration. We can only see "where" he saw and project the auratic depth onto the ensuing cultural artefact. If we take a position from Benjamin (the loss of aura in distraction and reproduction) and Sontag (the superficiality of the photographic moment), then the apprehension of authenticity is barely possible in the modern world and that, combined with economic exploitation, produces the risk of destructive and exhausting superficiality. "Taking photographs has set up a chronic voyeuristic relation to the world which levels the meaning of all events... today everything exists to end in a photograph" (Sontag 1977). In the age of mass-tourism the journey is a conduit that links places that are increasingly pre-determined as curated stops for the distanced viewing of landscapes as moments of self-narrative, an opportunity for confirming and constructing a social exposition that is more important than the actual experience of being present. Place is a scenography for the performance of self in the construction of identities with the image of self in place as evidence.

John Urry defines four types of spatial consumption as commercial, visual, devouring and engaging, in which the "devouring" presents the greatest risk. "Places can be literally consumed; what people take to be significant about a place (industry, history, buildings, literature, environment) is over time depleted, devoured or exhausted by use..." (Urry 1995).

This risk takes the form of the reduction of the authenticity and context to a focus on the maintenance and eventual falsification of surface. In a pessimistic post-modern view, we are reduced to selves without depth, a collection of temporary enacted appearances in places without substance. Conversely in a positive sense we can see spatial socialisation as the cultural construction of place myth and place images as a valuable mode of sociality that can lead to demands for a sustainable maintenance of authenticity.

For better or worse, tourism and its imagistic demands come to dominate the organisation of increasing aspects of cultural and social experience. Architectural colour, urban colour and landscape identities are a key component in this process and pose both some of the best possibilities in the maintenance and production of place and also some of the greatest risks in relation to the pressures of commercial distortion and fabrication. The colonising touristic gaze drives the false enhancement of environments for visual consumption; Images that once brought the place to the viewer in a time when most were unlikely to consider traveling now bring ever increasing numbers of viewers to the place in pursuit of the superficial pictorial moment.

## REFERENCES

- Andersen, S., and J. Brønne. 2006. Kulturminneforvaltningens og planarbeidets historie på Røros. Kulturarv og verdiskaping. Økonomiske virkninger av kulturarven på Røros. *NIKU Rapport 10*.
- Benjamin, W. 1935. The work of art in the age of mechanical reproduction, transl. by H. Zohn. In: *Illuminations*, H. Arendt, ed. New York: Schocken Books, 1969.
- Bjerke, Ø. L. S. 2018. Vinternatt i fjellene. In: *Harald Sohlberg: Uendelige landskap*, M. B. Guleng and M. Yvenes, eds. Oslo: Hirmer Verlag.
- Bye, M. 2008. A changing townscape: Røros throughout a century of heritage management. *16th ICOMOS General Assembly and International Symposium - Finding the spirit of place – between the tangible and the intangible*, Quebec, Canada.
- DETOUR. [www.vegvesen.no/265334/detour-nasjonale-turistveger](http://www.vegvesen.no/265334/detour-nasjonale-turistveger).
- Guttormsen, T. S., and K. Fageraas. 2011. The social production of “attractive authenticity” at the World Heritage Site of Røros. *International Journal of Heritage Studies* 17 (5).
- Harvey, D. 1991. *The conditions of postmodernity – An enquiry into the origins of cultural change*. Oxford: Wiley-Blackwell.
- Hult, M. H. 2003. *Framing a national narrative: The legend collections of Peter Christen Asbjørnsen*. Detroit: Wayne State UP.
- Lysholm, H. 2008. *DETOUR: Architecture and design along 18 national tourist routes in Norway*. Oslo: Norsk Form.
- Morgenbladet*. 2007. [https://morgenbladet.no/kultur/2007/juryen\\_har\\_ordet](https://morgenbladet.no/kultur/2007/juryen_har_ordet).
- Opstad, L. 2014. Harald Sohlberg. Norsk kunstnerleksikon; [https://nkl.snl.no/Harald\\_Sohlberg](https://nkl.snl.no/Harald_Sohlberg). Access: 27 May 2019.
- Solnit, R. 2006. *A field guide to getting lost*. London: Penguin Random House.
- Sontag, S. 1977. *On photography*. London: Penguin Books.
- Urry, J. 1995. *Consuming places*. London: Routledge.
- Witoszek, N. 1998. *Norske naturmytologier: fra Edda til økofilosofi*. Oslo: Pax.
- Žagar, M. 2009. *Knut Hamsun: The dark side of literary brilliance (New directions in Scandinavian studies)*. Seattle: University of Washington Press.

# Watercolor: a powerful tool to study the colors of the landscape

Elisa Cordero-Jahr<sup>a\*</sup>, Javiera Muñoz<sup>b</sup>, Daniela Caro<sup>a</sup>, Marjorie Delgado<sup>a</sup>

<sup>a</sup> Architecture and Arts Faculty, Universidad Austral de Chile

<sup>b</sup> Independent artist

\* elisacordero@uach.com

## ABSTRACT

Throughout history, watercolor has been used by artists with different purposes. First year students of the Design program at Universidad Austral de Chile used watercolors as a color observation method. The study site was the island of Mancera, at the crossing of Cruces river with the Pacific Ocean. The journey and the observations made were the input to find the adequate concept to design a book. Once the course was over, the professors in charge made an analysis of the results, both of the watercolor and of their use in the final product, with the purpose of assessing the use of watercolor as a tool to study color. The findings and the discussion are presented, concluding that the use of this technique at pre-graduate level in design programs could become a powerful research tool to understand and apply spatial chromatic relationships.

**Keywords:** *watercolor, design, teaching*

## INTRODUCTION

Due to their portability (you can even carry them in your pockets), many artists and professionals use watercolors in their notes of urban and natural landscapes. A watercolor made on site may be intended as a work of art itself, a note for a larger work in a different technique (for instance, an oil painting), or a rough draft to remember certain colors that will be used later.

As any sketch or note, watercolors not only contain what you see in the paper; additionally –given their immediacy– they project in the paper all the previous attempts dismissed by the artist. Every satisfactory sketch encompasses all the tryouts that the artist considered as lacking. Such a way of working encourages the artist to make a large number of attempts –which may lead to what has been misnamed as an error or accident– so as to manipulate it, change it or reinvent it.

Albrecht Dürer was an observer of nature and totally transformed this painting technique by means of transparent and overlapping gouaches, achieving several color and depth effects. Another paint master who improved the technique with impressive skills was William Turner. Eugene Delacroix also made watercolor sketches during his trip to Morocco, which he then transferred to oils. In present times, the watercolor technique has been developed by artist such as Gerhard Richter,

Marlene Dumas, Tim Gardner, Emil Nolde, and Thomas Gainsborough; while in Chile, some figures are Lea Kleiner, Adolfo Couve, and Hardy Wistuba (Figure 1).



Figure 1: Watercolor in landscape, used for botanical illustrations (a. Dürer), as landscape notes for a later work in oil (b. Turner, c. Delacroix), and as a final work (d. Nolde, e. Kleiner).

Unlike Europe, which is marked by history, the Latin-American landscape is strongly focused on geography, where the human presence is not the protagonist.

Nature in Chile's south is known for being untamed, with inhabitants scattered throughout its geography and a climate strongly marked by constant rain and humidity, volcanoes, rivers, lakes, glaciers, the Pacific Ocean, and the Andes Mountain Range. Nature is not only beautiful and exuberant, but also hostile. It emerges suddenly and claims to be heard. Nature shapes the perceptions of all its inhabitants from a perspective that resembles that of the Romantic German painters, who see human beings withered before the greatness of nature; as if humans had merged with the landscape.

## METHODOLOGY

Amidst this scenery is Universidad Austral de Chile, which in year 2018 opened the Design program. The first-year course, "Composition and Expression the Configuration of Design Projects" is aimed at making students define a formal proposal sustained in the discrimination of variables in order to work out a design problem. Given the school's territorial and local hallmark, the place of study chosen was the historical island of Mancera, located at the confluence of three rivers and the Pacific Ocean. The workshop thus posed the following question: Can the watercolor technique be used with first-year students as a means to study color in the landscape?

A different way of using watercolors is through a sketch, in order to understand, by doing, certain spatial chromatic relations existing in the landscape. This methodology has been used to grasp colors in the course "Composition and Expression in the Configuration of Design Projects" of the first-year Design program at Universidad Austral de Chile, Valdivia. The watercolor technique was selected considering the students' need to capture their immediate environment in a territory identified by a

changing atmosphere. The analogy flows naturally: In an environment marked by water, rivers, and rainfall, using a technique based on moisture and aqueous movement is ideal for the exploration of landscapes and their colors.

The goal of the class is “for students to define a formal proposal based on the discrimination of variables, to address a design problem”. Given the regional and territorial hallmark of this Design School, the professors in charge of the course decided to take the historical island of Mancera as the study space. This island is located at the confluence of the Pacific Ocean and the Cruces river. The final graphic proposal was expected to be a book that could display, in images and text, a journey through the island.

In the area of design, the observation method is defined as a creative exercise of perceiving the world. Since this depends on our gaze, it reveals differently to every person. In this sense and according to architect Fabio Cruz (1993), “the human condition is poetic and therefore, humans live freely in the wakefulness of making a world”. Observation, formed by a sketch (a watercolor in this case) and a written note, create a tool by means of which an observer accesses the place’s spatial relationships.

Artist Javiera Muñoz was invited to make a watercolor workshop to teach students the technique by means of the use of strokes, wet-dry, application in landscapes, color mixtures, and other related exercises. Then, the students travelled to the island of Mancera several times with the purpose of observing the horizon through watercolor sketches. Each student made approximately twelve watercolors, which were the conceptual input based on which they proposed their personal graphic discourse in the form of a book. The works were assessed based on the consistency of their concept and the final output.

## **RESULTS**

This work will show the analysis of the role of watercolors as a color observation tool in the landscape in the course “Composition and expression in the configuration of design projects”, based on the following aspects: The quality of the technique achieved by the students; the modification of color in the watercolors through the different phases of the model; the language of color; the watercolors in relation to the final design; and finally, the students’ own assessment of the experience. This analysis was instrumental to evaluate the role of watercolor as a color observation tool and to improve its use and application in a future design workshop.

The technique: Once the course was over, the artist was invited to review all the watercolors (more than 250) in order to assess whether the students managed to grasp the technique. The works were classified into two sets –achieved and non-achieved– as deemed by the artist. The selection criteria were technique use, strokes’ subtlety, personal expression and color management (Figure 2).

The transformation of color: During the course, watercolor was used as an observation tool. However, when the students began to design the final notebook, several models of the book were made that changed and improved over time. For that reason, the watercolors were remade several times changing their formats, to be consistent with a graphic discourse. Sometimes, quality was kept while others, it was neglected (Figure 3).



Figure 2: Color observation is closer in the left watercolor: different shades of green are distinguished and created through mixtures. The watercolor in the left is used as tempera, directly from the tube. Source: Design School, UACH.

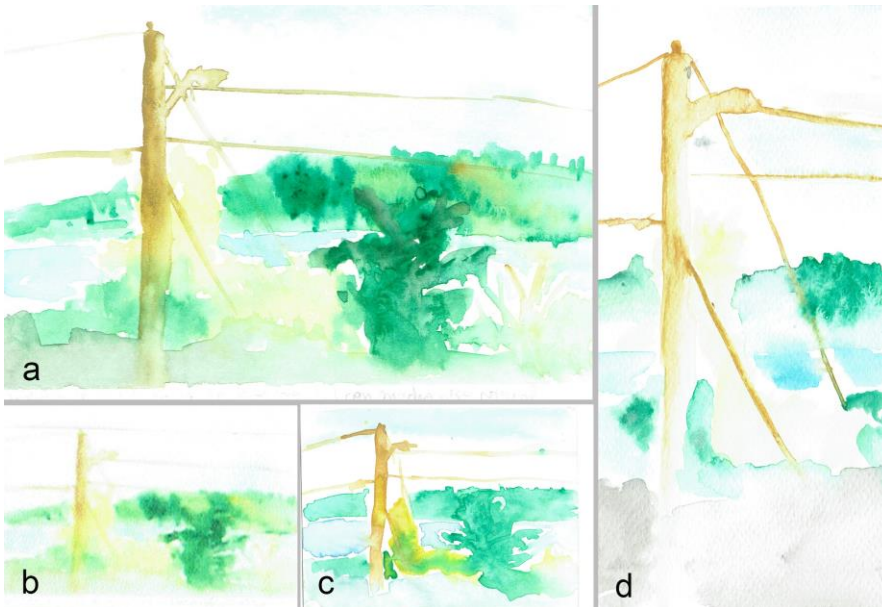

Figure 3: a) Original watercolor. b) Reproduction for a small model. c) Reproduction for a medium-size model. d) Reproduction for the final book. The student maintained the colors, but not the original format. Source: Design School, UACH.

Language of color: In general, we often say nothing about colors and their relationships. We mostly speak of light, darkness, and shades. However, watercolors have a very evident and sensitive work with color. There is therefore an absence in the language of color, but not of its uses. This could be due to the fact that, according to Ingrid Calvo, in the context of Chilean education: “Color is not associated to specific contents in artistic education programs, which has deep impacts on higher education, on project-related disciplines associated to art, design, and architecture” (Calvo 2015: 9). Color management: The students who observed the color of the landscapes were those who used the paper’s white as light, the mixture to obtain a more complex range of colors, the wet technique to get more shades, and the use of contrasted colors. On the contrary, a poor use of the technique by other students –compounded by a lack of language– prevented them from even making spatial color observations (Figure 4).

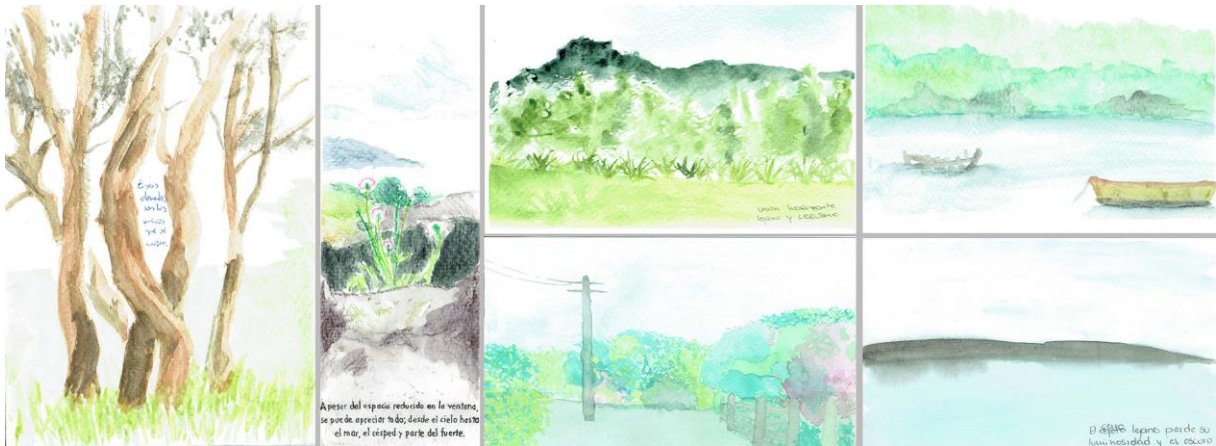

Figure 4: Sample watercolors with proper use of light, mixtures, wetness, and contrasts. Source: Design School, UACH.

Watercolor versus final design: The final grades of the students' works were compared with the selection of watercolors classified by the artist as "achieved and non-achieved". Within the works classified as "achieved", the artist selected watercolors made by 11 students, whose final grades averaged 5, which in Chile is equivalent to "good". Within those classified as non-achieved, the artist selected watercolors made by seven students whose final grades averaged 4.4, which in Chile is equivalent to "average". In the group of achieved works grades ranged from "very good" to "deficient" (1 case). Within those classified as non-achieved, there are no "very good" grades but several "deficient" (Figure 5).



Figure 5: Upper row, four watercolors classified as "non-achieved" belonging to the same student. However, the student managed to make observations and propose a consistent graphic discourse with her concept, getting an "average" grade. The bottom row shows the student's extended book proposal. Source: Design School, UACH.

Students' assessments: At the end of the course, the students were surveyed about their experience with the watercolor technique. Facing the statement: "It was easy for me to learn the watercolor technique", 55% answered yes, 40% answered no, and 5% didn't know. Facing the statement: "Using the watercolor technique was useful for my 2018 Composition and expression workshop", 73% responded yes, 13% answered no, and 14% did not know. Facing the statement: "Using watercolor improved my perception or knowledge about color", 68% answered yes, 23% answered no, and 9% didn't know. Facing the statement: "I could or have used it in other works



during my career”, 82% answered yes, 14% answered no, and 4% didn’t know. And facing the statement: “I would like to learn and experiment more with this technique”, 77% answered yes, 5% answered no, while 18% did not know.

## CONCLUSIONS

We can conclude that the overall experience with watercolors in the first year of the program was positive, although some aspects need to be improved. Concerning the technique, we recommend a longer or more intensive training. Given the short time devoted, there was a large share of non-achievers among the students. In addition, during the survey almost half of them reported that the technique was “not easy to learn”. Considering that almost 80% of them answered in the survey that “they would like to learn and experiment more with this technique”, devoting more time could meet great acceptance among the students.

The professors in charge failed to put enough attention to the transformation of color during the design process. This detail emerged only after the subsequent analysis made for this presentation, once all the watercolors were available. A further teaching experience should be particularly rigorous in addressing this aspect.

Color-related language is another shortcoming among the students. As mentioned in the results, this is explained by poor training during regular schooling. It is therefore required to ask the students to properly name what they are observing and sketching in their watercolors, in addition to supporting their learning process with additional teaching materials, perhaps in the form of multimedia. This topic should be developed over the entire program.

Color management was intuitively introduced by many students by using a good technique. While many were not able to name what they saw, they could capture the subtleties of color changes, lights, contrasts, and the varied ranges created by mixing colors. Perhaps a further reflection is required in this particular issue, supported by the artist, in order to “become aware” of what one has made.

Concerning the handling of watercolors and the design of the final product, the purpose of which was to layout a book, it was observed that the outcome of the watercolor is not always consistent with the outcome of the final product. While some students were not able to incorporate the technique, they did make observations and reached a satisfactory outcome. While the skills involved are different, if both are managed well better outcomes can be expected.

The students surveyed were in general open to continue exploring, learning, and using the technique for different purposes. This shows that beyond the experience of a couple of weeks in a first year –and the difficulties involved in its knowledge– watercolor appears as agreeable to young designers. We therefore recommend its use given its friendliness and versatility, and because it is a good way to start expanding perceptions, creating color language awareness, and sharpening the observation of color.

## REFERENCES

- Calvo, I. 2015. *Informe de estado del arte. Recursos para la enseñanza aprendizaje del color*. Fundación Mustakis: Internal document of the Foundation.
- Cruz, F. *Sobre la observación*. 1993. Online: <https://www.ead.pucv.cl/1993/sobre-la-observacion>.

# Between skin and landscape: color as a mimetic agent

**Lilian Walker**

Universidade Estadual de Campinas, Brazil  
lilian.walker@gmail.com

## ABSTRACT

This article presents a reflection on the possible poetic and visual convergences between body and landscape, permeated by an interpretation of the concept of mimesis in my artistic work. From the identification of similarities between the associated elements, new similarities are produced, a process in which color is a determining factor for the technical procedure performed. I propose a descriptive approach to this authorial artistic procedure as the basis for the discussion.

**Keywords:** *landscape, body, color, mimesis, visual arts*

## INTRODUCTION

Landscape, as a genre of art, has undergone a series of transformations over time, following the same paradigm breaks that have taken place in all fields of artistic production. We can say that for a long time, painting has had as its primary function the representation of nature, and the exact fidelity of this representation was of great relevance. In this sense, the classic concept of mimesis was fundamental within the development of Western painting, also incorporating the contours of its transformation.

As Gage (2012) comments, color appears as a basic element in visual representation, since, for painters of the landscape genre, the fidelity to the colors of external space was an essential aesthetic objective within the prevailing mimetic premise, although the sense of "fidelity" varied much from one artist to another.

In fact, in terms of representation, it is possible to think of color as an expressive sphere of connection or break with reality, within the framework of a principle of recognition and construction of similarities. The color choices made by artists can denote their intention of correspondence or transgression as to the appearance of things in the world, as well as the desire to simply employ visual signs, symbolic senses.

The artistic work that I address in this paper starts from a displacement of landscape representation, in which I identify a link between landscape and the surfaces of the human body, a relationship made possible, among other factors, by the technical procedure which draws mainly on

color to achieve the proposed convergence. Before entering the specific issues of the work, it is necessary to situate some concepts.

## THEORY

With Aristotle (in Durix 1998: 45) we have an interpretation of mimesis based on the biological model, recognizing mimetic activity as a behavior proper to human nature, prior to language: “the ‘natural’ human inclination to imitate is inherent in man from his earliest days; he differs from other animals in that he is the most imitative of all creatures, and he learns his earliest lessons by imitation”. Such activity assumes its own character in the human species because it is configured as an intellectual exercise, loaded with reason and creativity and one cannot imitate without imagining and comparing, as Nunes (2006) points out.

Walter Benjamin (2013) highlights, instead of *recognizing* similarities in the reproduction of reality, the importance of the *production* of similarities, stating that looking at the sphere of the similar should consist less of imitation than of the reproduction of processes that engender visual proximity.

Thus, despite the appreciation of likelihood in the mimetic process, there is a fictional nature linked to it, especially if we think of artistic creation. For Cauquelin (2008), mimesis is not a copy of a model, but, first and foremost, creative, affirmative, autonomous. If it repeats or imitates, whatever it repeats is not an object but a process: producing in the same way that nature produces, in order to give existence to an object or fictional being, an artifact.

Takahashi et al. (2010) confirm this by stating that although it refers to similarity and does not deny imitative inspiration with pre-existing signs, or creating interfaces of associative interpretation with other signs, mimesis is always employed as a process of resistance to established reality, with strong appeal to myth.

We see, then, that mimesis can be used to reflect an activity that simultaneously touches reality and transforms it, recreating the parameters of observation of the real through new correlations. According to Bourriaud (2009), art assumes this role, since it deals with the real, but questions its conception, transforming reality into a façade, into a construction.

Therefore, amid this process of inventive imitation, mimetic activity makes the distinction between the subject and the other more flexible. Rather than dominating nature, mimesis opens a sensory experience of the world in which the Cartesian categories of subject and object are not fixed. The subject surrenders to nature and assimilates to the objective world rather than anthropomorphizing it into his own image (Taussig 1993).

## RESULTS AND DISCUSSION

In the following authorial artwork, I explore this mimetic operation of association between subject and nature in a series of large-scale hybrid paintings called “Crosta” (“Crust” in Portuguese), a title that refers to both the most superficial layer of the Earth and the scab that may form at the surface of the human skin. I propose fragments of the body as landscapes through framing, enlargement, chromatic appeal and pictorial manipulation. The surface of the body is treated in the manner of topographic images and its textures and contrasts are intensified because of the scale and the painting that blends with photography, increasing confusion with a landscape.

In my work, it is on this surface that the mimetic key is found, which makes the categories of subject and object less rigid and more fluid, and the recognition of the similarities between body and landscape provides a production that intensifies them. Thus, the focus of mimetic activity is on the “frontier” of this “body-territory”: on the skin.



Figure 1: *Calcária*, from the series “Crosta”, oil and digital print on canvas, 132 × 214 × 3 cm, 2019. Photography made by Pablo Gea, August 2019.

I photograph the skin, with an approximate focus of a specific part of the body, on whose appearance I perceive a landscape. Then, after transferring the image from the digital platform to a printed medium, I reinforce and intensify the similarity observed with the painting, bringing new volumes, shapes, tones and compositions. My intention is to establish correspondences, fusing the texture, tones and volumes of the skin register and the added ink, without disfeaturing it, each one supporting its respective roles.

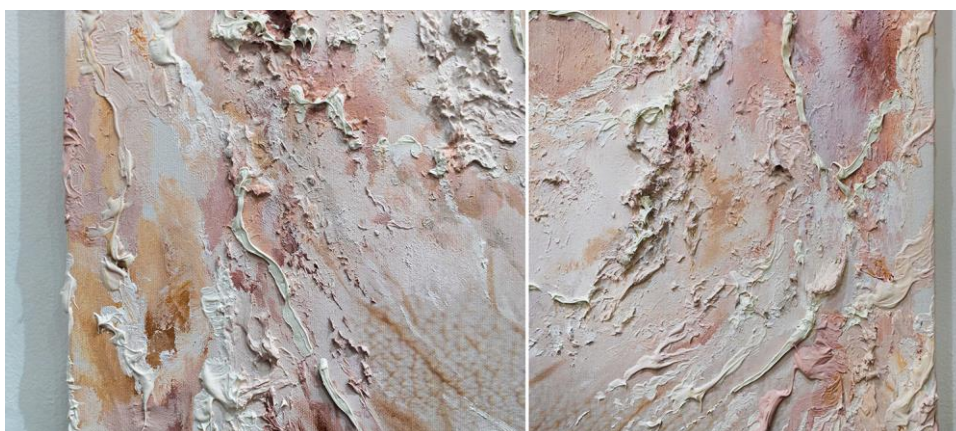

Figure 2: Details from the work *Calcária*. Photography made by Pablo Gea, August 2019.

It is the performance of painting that indeed establishes the union, creates the bond and gives life to the landscape recognized in the skin. It sometimes enters subtly through the gaps of the figure,

filling in remote and blurred areas, seeking to achieve the printed color with maximum accuracy. A light but fundamental move to bring together photography and painting, to the point of confusion. At other times, the painting is emphatic, affirming its presence with the contrast of color, in dark and light tones, and the contrast of volume, coupling charged masses amid the flat surface of the canvas.

Color is a determining factor in this process, since it is the main link of visual correspondence between printed image and painted image, between natural landscape and fictitious landscape. Color is the central datum for the definition of composition, contrasts, regions of light and shadow. It is also the use of color that defines the degree of proximity and ambiguity I establish between photography and painting. The tones of the skin dialogue and converge with the earth tones, which are complemented with greenish, pink, orange and white notes, with lights and shadows that evoke the volumes of reliefs and plateaus. Thus, I consider color one of the main components within the mimetic movement that I seek to develop.



Figure 3: *Humosa*, from the series “Crosta”, oil and digital print on canvas, 132 × 195 × 3 cm, 2019. Photography made by Pablo Gea, August 2019.



Figure 4: Detail from the work *Humosa*. Photography made by Pablo Gea, August 2019.

In fact, as Guimarães (2004) shows us, employed with intention and purpose, color functions as a sign when it is received by vision and updated by the perception and interpretation of its materiality, a process in which visual perception plays a large role, suffering the influence of hereditary, cultural codes, that is, the individual repertoire of the receivers.

Its importance is revealed throughout my creative process, before the result seen in the finished work, before painting and even photographic printing. From skin seen in natural light, through the camera's viewfinder, computer screen, to the desired media, it is relative layers and perspectives that influence the outcome, such as monitor calibration, image editing adjustments, and perceptions of those involved in the whole process. In this path, then, I must also consider the differences in color-governing systems in the monitors and the graphics industry, making the necessary compensations and tests.

When receiving the finished print and beginning the development of the painting, I have to mix many different pigments to achieve the printed tone, recognizing the richness and variety of colors in the print. Excessive mixing results in a decrease in brightness and chromaticity, revealing a lowered palette, with a predominance of gray and earth tones. In addition to this natural tendency, from what the image itself offers, I use strategies in painting that also serve to remove the vibration and intensity of colors, actions that refer more to an action of "smearing" with the paint. I'm interested in the mingling of the remnants, in that the tone used in the corner of the screen is still somehow on the other side of it, in that the impurity intensifies. Thus, I make the composition a unit, the layers converge and it is not clearly distinguished where there is painting, where there is photography.

The character of this operation of constant color metamorphosis reflects the ephemeral state of skin and landscape in all its senses. Media of time and terrain of registration of the marks of human relations are both susceptible to erasure and new inscriptions. Therefore, a standardized body that aims to mimic unchanging territory that is unaffected and unmixed is exhausted in its own effort.

The ambiguity developed between skin and landscape, between the microscopic and the topographic, through the hybridism of technique and the use of color, also reflects the paradox of the contemporary skin of urban masses, in which the identity and autonomy of bodies is often dissolved: the closer, the farther, of what is intrinsically our (body) seen as external to us (landscape).



Figure 5: *Argilosa*, from the series "Crosta", oil and digital print on canvas, 147 × 214 × 3 cm, 2019. Photography made by Pablo Gea, August 2019.

Importantly, in contemporary art, representation is always at the service of a conceptual proposal, not an end in itself. In this way, color acts as an essential agent within the path necessary to achieve the desired reflection, and is not a mere optical or decorative resource. Therefore, color as a mimetic agent is not dedicated to the faithful reproduction of reality, but to the creation of a fictional, imaginary structure that corresponds to the natural process, and provokes recognition, but without being equal.

## CONCLUSION

With this brief descriptive presentation of a particular stage of my creative process, I sought to demonstrate the relevance of cautious and directed use of color to draw the desired poetic and conceptual parallels, emitting coherent and effective visual information.

The questions raised brought the concept of mimesis to the context of contemporary visual arts, highlighting the possibility of an update of representative approaches, subordinated to the fictional character that the mimetic activity proposes, seen in the specific use of color in my creative process.

## ACKNOWLEDGEMENTS

I thank FAEPEX and PPGAV, both from my university Unicamp, for the financial aid, and CAPES for funding my research.

## REFERENCES

- Benjamin, W. 2013. *Escritos sobre mito e linguagem: (1915-1921)*, compiled by J. M. Gagnebin, translated by S. Kampff Lages and E. Chaves, 2nd ed. Sao Paulo: Duas Cidades Editora.
- Bourriaud, N. 2009. *Pós-produção: como a arte reprograma o mundo contemporâneo*. Sao Paulo: Martins/Martins Fontes.
- Cauquelin, A. 2008. *A invenção da paisagem*. Sao Paulo: Martins Fontes.
- Durix, J.-P. 1998. *Mimesis, genres and post-colonial discourse: Deconstructing magic realism*. New York: MacMillian.
- Gage, J. 2012. *A cor na arte*. Sao Paulo: WMF Martins Fontes.
- Guimarães, L. 2004. *A cor como informação: a construção biofísica, linguística e cultural da simbologia das cores*, 3rd ed. Sao Paulo: Annablume.
- Nunes, B. 2006. *Introdução à filosofia da arte*. Sao Paulo: Ática.
- Takahashi, J., et al. 2010. *Leituras do corpo*, 2nd ed. Sao Paulo: Annablume.
- Taussig, M. 1993. *Mimesis and alterity: A particular history of the senses*. London: Psychology Press.

# Colours of clothing as a factor influencing the colour scape of cities

Maryam Alsadat Mirian, Forough Mahyar\*

Art University of Isfahan, Isfahan, Iran

\* f.mahyar@au.ac.ir, fomahyar@yahoo.co.uk

## ABSTRACT

The idea of this research came from the concept that the colours of people's clothing would play the main role in creating the colour scape of a city. The aim of this research is to apply the colours existing in the culture of Iran, for everyday clothing. The pictures, illustrations and itineraries were applied from the Qajar era between 1789 and 1925. All the colours in the images were pixelated in order to find the number of colour pixels which were covered by each colour. Based on the Natural Colour System, the NCS codes that nearly match to the detected colours were identified. According to the obtained colour groups, new clothing was designed. The colours which were obtained in the current research can be used to modify contemporary clothing and therefore the city colour scape.

**Keywords:** *colour, clothing, colour scape, Qajar era, Natural Colour System*

## INTRODUCTION

Colour scape is affected by the colour orders and colour harmony of the colour combinations in buildings, pavements, and architectural elements in cities. Due to the point that city main colour is not equal to building main colour (Gou 2007, 2007a), the colours of the clothing worn by people can be connected to the everyday view of the city we are living in. It is not avoidable to consider a cityscape without people in the city sites. People and the colour combinations of their clothing make different sceneries in daily life of a city. It seems that when people walk through the pavements, streets and alleys with black and grey clothes, the city seems gloomier. Based on the authors' initial observation in the cities, nowadays people, living in different cities in different countries especially in Iran, mostly wear black, dark blue and a wide range of greys (achromatic) clothing. Surprisingly, according to the historical studies (Alimohammadi 2012, *Encyclopedia Iranica* 1992), the relevant works of literature confirm that, in Iranian culture, people preferred to wear colourful clothing including different ranges of hues in. The current research has been defined to investigate the colours and colour patterns in ancient clothing in Iran. The existing colour patterns in Iranian clothing, imply that the arrangements of clothes' colours included a wide range of hues, chromas and lightnesses. By reviewing the history of applied colours in Persian costumes, a lack of sufficient documents limits the current research to the Qajar era.



The Qajar dynasty has an Iranian pedigree and was founded in 1796 by Agha Mohammad Shah, chief of the Quvanlu branch of the Qajar tribe and ruler in northern Persia. The Qajar era lasted seven generations until 1925 (Weardon and Baker 2010). Women clothing in the Qajar era was divided into two categories including inner and outer clothing. The reason that the current research focused on the Qajar era was due to the diversity in different colours and forms in women's clothing.

## EXPERIMENTS

Documents which were applied in the current research include paintings and images that represent Qajar clothing. The existing paintings in museums such as Victoria and Albert, The State Hermitage, Brooklyn Museum and also Golestan and Sa'dabad palaces were used in the research. There are different collections of paintings at these museums but only a selected range of eighteen authentic and valid pictures was used in the research. Documents validate the authenticity of the colours used in pictures, compared to the costumes that would be used and worn in the Qajar era.

All colours in the selected images were pixelated in order to find the number of colour pixels which were covered by each colour. The occupied areas of each colour were measured and for each image, the first three colours, which cover more surface area than the others, have been selected. All the pictures were observed by a MacBook Air 2015, 13.3 inches, being set in the highest brightness. All the three colours which occupied the most area in the images were displayed on the screen in a near size of the colour patch in the NCS atlas. Figure 1 shows the screenshot of the display during the experiment.

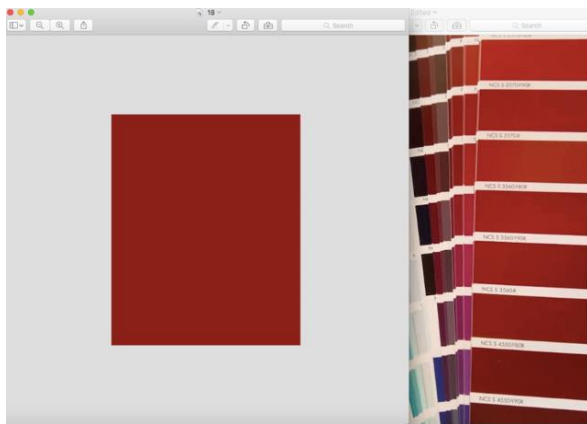

Figure 1:  
A screenshot during the assessment.

Six observers, with a normal colour vision, who have passed the Ishihara test, and including four females and two males assessed the colours. Based on the NCS colour system, the NCS colour codes which better matched to the displayed colours were identified.

New clothes were designed using the colours identified in the clothing of the Qajar era. The forms and techniques of Qajar women's clothing were translated into a new design by developing and making connections between the past, present and future.

## RESULT

The clothing which was illustrated in the images were assessed to find the most three occupied colours. Table 1 shows all of the three assessed colours in each image.

























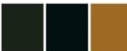









Order	Picture	Details	Main colours	Order	Picture	Details	Main colours
1		Amorous couple 131.5 × 77 cm Early 19th century Hermitage		10		Lady dancing and playing castanets 1800-1830 V&A	
2		Woman dancing 1800-1830 V&A		11		Woman playing a drum 1800-1830 V&A	
3		Woman holding a rose 184 × 94 cm The first quarter of the 19th century Hermitage		12		Woman playing a guitar 1800-1830 V&A	
4		Woman holding a diadem 159 × 89 cm Mid- 19th century Hermitage		13		A woman carrying a plate of sweets 1810-1830 V&A	
5		Dancing girl with castanets 158 × 90 cm The first quarter of the 19th century Hermitage		14		Seated woman playing a guitar 1800-1830 V&A	
6		Female tumbler 1800-1830 V&A		15		Woman playing a drum 1800-1830 V&A	
7		Female tumbler 1800-1830 V&A		16		Woman playing a drum 1800-1830 V&A	
8		Blouse 1800-1840 V&A		17		Woman with a child 1800-1830 V&A	
9		Seated woman pouring wine 1800-1830 V&A		18		Panel 1800-1830 V&A	

Table 1: The first most occupied area colours in each image.

Table 2 illustrates all identified colours based on the NCS colour atlas. Based on the results in Table 2, the three colour groups which were mostly seen in the Table were presented.



















				
1	2	3	4	5
#7b2f0b L:30, a:26, b:30	#2b171f L:11, a:9, b:-1	#3b272d L:18, a:8, b:0	#2b4f50 L:31, a:-10, b:-4	#a13814 L:39, a:35, b:34
				
6	7	8	9	10
#970315 L:32, a:44, b:27	#c27c00 L:58, a:19, b:54	#e46f54 L:61, a:36, b:31	#893e2a L:36, a:25, b:23	#102b2f L:16, a:-7, b:-5
				
11	12	13	14	15
#b45b35 L:49, a:28, b:32	#160e0f L:5, a:3, b:1	#a3690f L:49, a:16, b:46	#313932 L:23, a:-3, b:3	#985d2f L:45, a:18, b:31
				
16	17	18		
#95663f L:47, a:13, b:26	#1b222e L:13, a:-1, b:-8	#980000 L:32, a:44, b:32		

Table 2: All identified colours according to the NCS colour system.

According to Table 2, all obtained colours were categorised into nearly colour family or colour groups. Table 3 shows the three colour groups which were illustrated based on the NCS colour system. Based on the colours which were found in Table 3, the final design of clothing is shown in Figure 2.



Chart #105 NCS S25 70R



Chart #155 NCS S45 50B



Chart #5 NCS S30 20 Y50R

Table 3: Three final colour groups.

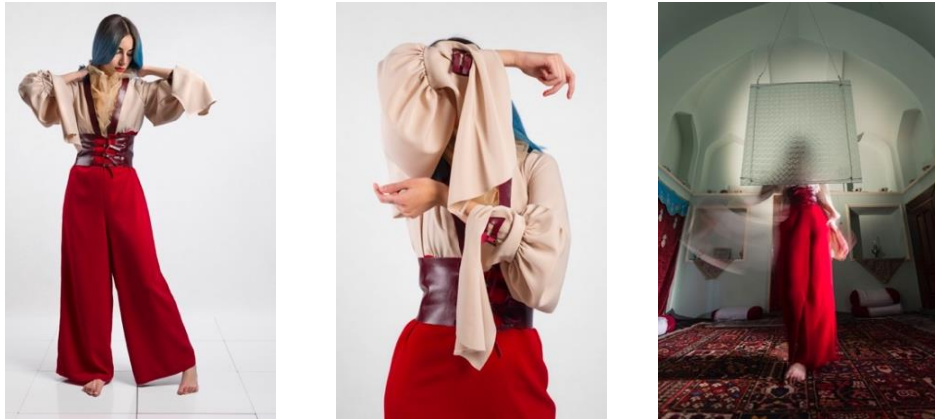

Figure 2: The final design of clothing based on the obtained results in the current research.

To investigate the effect of wearing clothing consisting of the colours which have been found in the current research on the colour scape of the cities, an image which was taken in Naghsh-e-Jahan square in Isfahan (Figure 3, right) have been assessed by fifteen observers. They have included seven females and eight males in the age range of 19 to 38. The observers were asked to look at the photo and select a number of one to five according to the feelings which they were induced. The words which have been asked were joy, liveliness, and beauty. The same assessment was done for the image (Figure 3, left) in which people’s clothing was modified based on the results of the current research by the same observers. Table 4 shows the obtained results of the assessments.

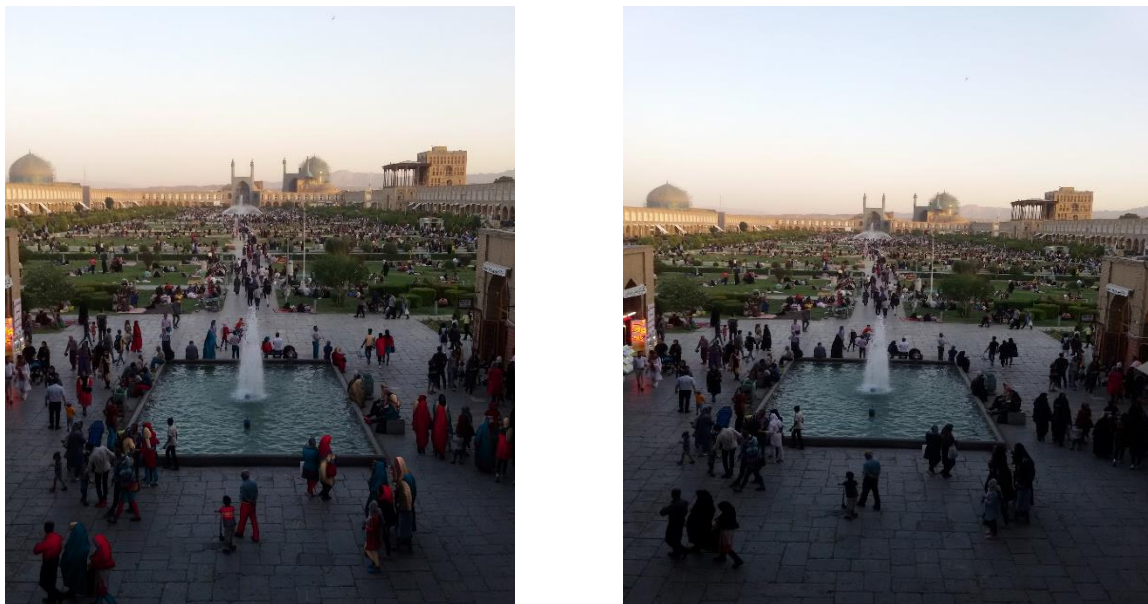

Figure 3: The photo was taken in Naghsh-e-Jahan square in Isfahan.

	Joy	Liveliness	Beauty
Original image	2.6	2.5	1.9
Modified image	4.5	4.6	3.9

Table 4: The average of the selected numbers by 15 observers for each image.

As shown in Table 4, there is a notable difference between the feeling of the observers with the normal clothing that people wear every day and with wearing clothing in the colours which were obtained in the research.

## CONCLUSION

Eighteen pictures of paintings related to the Qajar era have been investigated in the current research. NCS colour system was applied to find the most similar colours existing in women clothing of the images. Three colour groups were found as the main colour groups which were applied in Qajar era clothing. The forms and techniques are inspired by Qajar women's clothing. Based on the results of the research for designing colours and forms in clothing, an item of clothing has been designed. Applying the colours which were obtained in the research as the colours of everyday clothing seems to make the city a lively, joyful and beautiful place.

Due to geographical differences and the existence of different ethnicities and cultures in Iran, the current research is predicted to create a wide range of possibilities for further research, introduction, and development of effective colour charts based on the other Iranian cultures. The colours obtained from this research can be used to modify contemporary clothing and therefore the city colour scape.

## REFERENCES

- Alimohammadi Ardakani, J. 2012. *Synchronization of Qajar literature and painting*. Tehran: Yassavoli Publishing.
- Encyclopedia Iranica*. 1992. Edited by Ehsan Yarshater. Volume V, Clothing. California: Mazda Publishing.
- Gou, A. 2007. Spatial logic of architectural color: Werner Spillmann and the color planning for German township Kirchsteigfeld. *Architectural Journal*, 2007 (1).
- . 2007a. Performance of urban color planning in China. *City Planning Review*, 2007 (12).
- Weardon, J., and P. L. Baker. 2010. *Iranian textiles*. London: V&A Publishing.

# Cesia in nature and in the representation of nature. Luminous cesia: a special case

**Varinnia Jofré**

Universidad Nacional de Córdoba, Argentina  
varinniaj@hotmail.com

## **ABSTRACT**

We have naturalised colour as it appears in the matt opaque cesia, a homogeneous colour, distributed almost without change on the surface of objects, without being distorted by the reflection of light or by the colours of the objects surrounding it. Since the distribution of colour in the space varies in accordance to its cesia, such as has been systematised by Caivano (1991); from the perceptual point of view, it appears in our visual world associated to other phenomenal aspects, as postulated by Katz (1935: 7-9). Our proposal is to analyse cesia in nature and in the representation of nature, specially the luminous cesia, and to reproduce it. The luminous cesia (Jofré 2014), a reformulation that we proposed to the variable absorption of the system of cesias proposed by Caivano in 1991, includes the light itself —luminous colour, according to the denomination of Katz—, incandescence, phosphorescence and fluorescence, and also has temporal attributes. We can consider that the reflections of light in bright colours are also sensations of luminous cesia, since they are perceived and represented in a similar way.

In landscape paintings the attention to the cesia was belated, unlike the cesias of garments, which were meticulously represented. Umberto Eco comments that when John Constable realistically painted the glare, in *Wivenhoe Park* (1816), the meticulous representation of the reflection of light on the water and the fields, which seems photographic, was not interpreted as a form of imitation of real luminous relations, but as an odd whim. In later paintings, Constable advanced in the realism of representation of glare, and William Turner painted the luminous cesia of the sun and the fire.

Nowadays we can create our works with light, and with materials that reflect light in different ways. We make immersive landscapes inspired by nature in general, and specially in elements that emit light or re-emit it in different ways: in lightning, in the iridescence of certain plumages, in fluorescent corals, in the bioluminescent seas.

**Keywords:** *cesia, art, representation, natural landscape, perception*

## INTRODUCTION

In the natural landscape the luminous cesia is almost always present, we see it in the sun, which has its own light, and in things that reflect light with such intensity that they look luminous: the moon, the lightning, the sky, and all things that shine. During the day we see the sky and the sun, and we also find the sensation of luminous cesia in the shimmer of water, in clouds, in the iridescent plumage of some birds, in gold and silver, of schools of fish in underwater landscapes, and also in the rainbow, the northern lights, lightning and flashes of lightning. In the night we see the stars, and the luminosity of the moon, of lightning and flashes of lightning intensifies, and the luminous beings and things appear: the fireflies, which appear in large numbers in some places, the luminescent seas and reefs, the Waitomo caves in New Zealand.

In art, the representation of cesia has been fundamental to the realistic representation of the world. Realism, defined by its form, is one in which a high effect of reality is produced by a high level of similarity between the image and the referent, which can be imaginary; it exists in order to create an illusion of reality, allowing to create unreal worlds that seem real.

The iconic representation of light was achieved in painting in the fifteenth century. We could consider that, within the conventional symmetrical representations of Byzantine art, we can consider that the representation of the starry sky in the Ravenna mosaic of the Celestial Vault of the Gala Placida Mausoleum is a landscape sketch, where the glow of the golden stars represent the light.

But the iconic representation of light with the means of painting began to be incorporated into the landscape in the following century, in the visionary paintings of Tintoretto, in which the luminous vibrations of the landscape contribute to the miraculous sense of the sacred scenes. And it is only fully incorporated in the nineteenth century, in the realistic landscapes of Constable and Turner.

At present, light intervenes in art in different ways, it can even be the support of the work, but we can rarely find that this happens in the representation of a landscape.

Our research proposes to create landscapes with luminous cesia. We have experimented with light, with fluorescent colors and with transparent and bright sheets that transmit and re-transmit light. The proposal of our research was to create an environment: an artistic work consisting of a series of successive landscapes built in real space, which can be traversed inside by the viewer.

We raised the need to represent worlds that transmitted transcendence and spirituality which led us to the hypothesis that materials that convey the idea of immateriality should be used. In an earlier investigation, it was established that in painting and cinema the representation of elusive cesias had achieved this effect (Jofré 2017). This led us to use luminous cesia and cesias that reflect and transmit light. We have experimented with light, with fluorescent colors and with transparent and bright sheets that transmit and re-transmit light.

## ARTISTIC WORK

Within the framework of our research work, two artistic works were carried out in which the luminous cesia had a fundamental role in an experimental cinematographic short film, *Infinite: The doors of perception* (Melina Matélica, 2019), and a collective installation, *Landscapes and senses*.

The first one, inspired by Aldous Huxley's essays *The doors of perception* and *Heaven and hell*, is based on experimentation with hallucinogens, which connects with the inner world, a wonderful world that we visit only in dreams or in meditation, and in the search for the divine and

transcendence. The film shows the journey through a space landscape with lights suspended in space.

*Landscapes and senses* is an environment, within which the viewer travels. Different filmmakers show different representations of landscapes of America, which follow one after another. Some of them seek realism, while others take as a source of inspiration the worldview of the original peoples of America, their mythical relationship with nature, and altered perceptions produced by hallucinogens and mystical trances. The installation is oriented to an immersive reception based on experimentation with illusory spaces. These illusory spaces result in a distorted and enigmatic perception for the viewer who enters a space in which the artistic realization is on the ceiling, and through a mirror that is placed in front of his eyes, the viewer can only see what is above, but due to a physical-psychological effect, he sees it as if it were below, so that when walking he thinks he is stepping on it, and experiences a walk full of obstacles and diverse sensations.

This art that we call “space inversion”, is multisensory: the perception of the position of the body in relation to space, and also the view, is at stake, as if the depth of space was perceived for the first time.

## THEORY

We had reformulated the semiotic systematization of cesia, incorporating luminous cesia (Jofré 2014). The parameter that accounts for the light/dark axis is conceived by Caivano from the physical point of view as from the absorption: the ability of materials to absorb light. Considering that the levels of luminosity are not only produced by reflection or absorption of light but also by their emission, we proposed that this parameter should be incorporated and the axis inverted, which could be conceived from the replacement of absorption by emission, or both parameters could be considered interchangeably. Our proposal is to group both parameters into that of luminosity, which includes not only the absorption but also the emission of light (Table 1).

Parameter	Sensations	Depends on
Transmission	transparent / opaque	permeability
Diffusion	bright / opaque	diffusivity
Luminosity	luminous / dark	luminosity

Table 1: Parameters of cesia.

Luminosity, as we said, can also account for other modes of appearance considered by Katz, such as incandescence and fluorescence, and they also have temporal attributes. Fluorescence is a luminescence that occurs when stimulated mainly by ultraviolet light. Phosphorescence is a luminescence that persists long after exposure to a light source ceases. We had also considered it necessary to include other luminous phenomena that we find in nature: glow and iridescence. Glow is a form of specular reflection that we find on bright surfaces, which re-emit light, in which there are special modes such as pearl luster and metallic luster. Iridescence is an optical phenomenon that depends on the property of certain reflective surfaces on which the colors of the rainbow appear, not simultaneously, but the color of the reflected light varies according to the angle from which it is observed.



Regarding the application of studies on light cesia in artistic production, on the one hand we inquired into the iconic representation of landscapes. We followed the semiotic approach of the Groupe  $\mu$  (1992), in which there is transformation between the model and the representation: there are visual characteristics of the real world model, brands, which make it recognizable, and others contributed by the producer of the representation.

It is important to take into account that the brands that come from the producer, even if they are subjective, also come partly from the real world, from art and from theoretical models: producing a landscape that transmits spirituality requires of a process in which the real landscapes that have provoked that sensation on us, play an important role, and so does the study of the artistic works that provoked that sensation, and of the theory of art that guides us on the means to achieve it. For this artistic work we have selected both, the luminous cesia and the opposition light/darkness as the brand that represents spirituality.

We started from a study of the incomprehensible image (Jofré 2017). That study concludes that the image that effectively represents non-earthly worlds, freed from the limitations of nature, is a type of image that transcends the limits of its materiality. We made a theoretical journey on the transcendent image of different authors. Lessing described these images as “forms that leave room for imagination”. Wölfflin (1985: 84-88) describes them as open, weightless and unlimited, and to the darkness in which they are immersed as a continuity of space to infinity. Following Wölfflin, Floch describes them as dark, mysterious and disturbing. And Tatarkiewicz (2001), in his classification of forms, characterizes them as opposed to the form it calls “L”: the defined form, which encloses, which limits. He takes these concepts from Witold Gombrowicz, who describes this form as “a type of obligatory rule, a law that guides man but also overwhelms him”; the opposite of it is a certain indeterminacy, because there is less form in it, less limit, and more freedom.

We had come to the conclusion that the rules to build that freedom in order to produce spiritual sense, are the same rules that Wölfflin discovers in Baroque art: mainly indistinction, the lack of clear visibility. Light and the effect it produces on bright, reflective, and transparent cesias comply with this rule; as they are elusive, unlike opaque and matt cesias, which represent the apprehensive images of realism.

Wölfflin refers to the effect and the sense that some cesias produce when he says, for example, that the color of the objects does not remain the same as itself but rather “mirrors” with the most diverse colors, for that reason “the shapes are elusive, they appear and disappear [...] the edges are inconsistent, the surfaces avoid palpation. [...] The accent does not fall [...] on being, but on happening and metamorphosis;” the form “subtracts from determination and constantly changes and renews.” Wölfflin suggests the unrealistic appearance of this way of representing when he says: “palpable surfaces appear destroyed” and the figure appears in a vague way, unable to consolidate neither in the lines nor on the surfaces the tangibility of the real thing.

## **EXPERIMENTATIONS**

We considered how to solve artistically the different quests for landscape representation from these spiritual worldviews. We reached the need to provide a multisensory aesthetic experience, the stimulation of all the senses, inviting the viewer to build his from his own worldview.

It was foreseen that the luminous cesia would predominate in five of the landscapes. Fluorescent colors were chosen in one of them so that the landscape elements seem to emit light. It was extensively experimented with the entire color palette.

Another landscape was inspired by water, its transparency, and the reflections of the sky on it. This work was experimented with large sheets of recycled polyethylene. The effect was studied with transparent and semi-transparent engraving inks, and with reflective paints. Both inks and paints were experimented with lights of different colors, and with the change of colors and intensities in time (Figure 1).

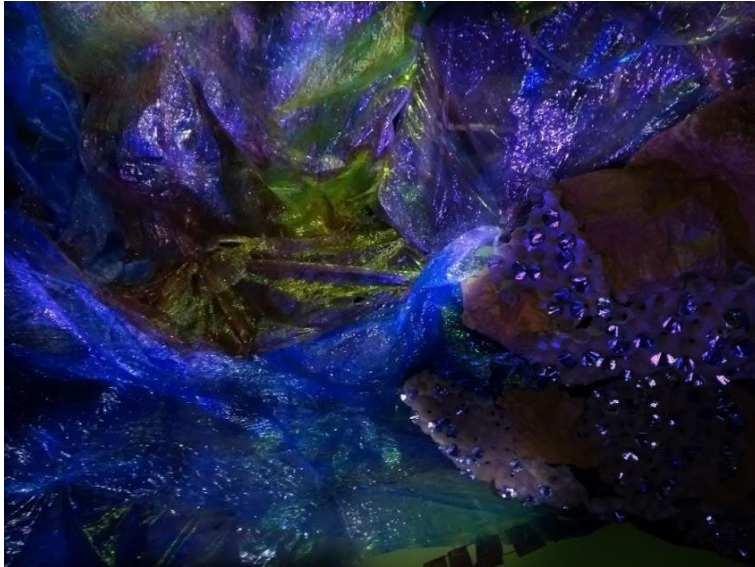

Figure 1: Aquatic landscape (Adriana Miranda and Laura Pedrerol).

Another one was a coral reef with RGB LEDs, with primary and secondary colors. A volcano with geometrized cracks, through which a red incandescence is seen. And finally, a night of lightning, in which the light/dark opposition plays a main role, but also the subtle tones (Figure 2).

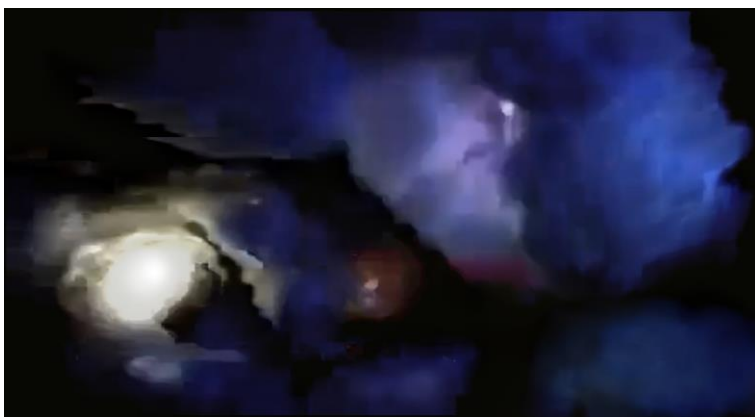

Figure 2: Lightning storm (Varinnia Jofré).

## RESULTS

White was chosen for the fluorescent landscape which resulted in a snowy landscape that emits light (Figure 3).

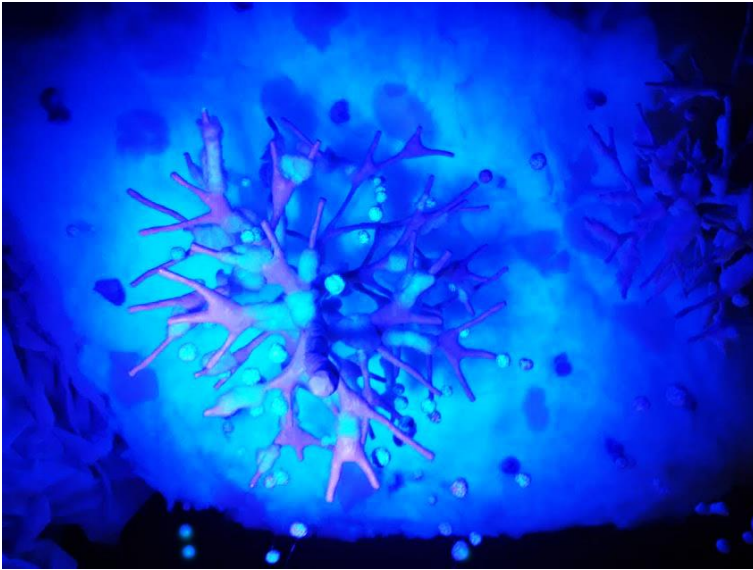

Figure 3: Snowy landscape (Silvia Albarracín).

The cesia of the material was capitalized for the aquatic landscape of polyethylene: both the transparency, illuminating it from the back, and the reflectance, illuminating it from the front. Light of various colors was used, trying to avoid saturated tones, and the intensity was also graduated.

The LEDs on the reef were removed and it was decided to illuminate it from behind. As regards the volcano, it was possible to see a plausible red glow in the background, through the cracks. The time variable, with a uniform and slow rhythm that produced a pulsating effect, was added both in an area of the water and the reef. And also, for the lightning storm, in which a minimally random sequence was achieved.

The light/dark opposition played a fundamental role. An unexpected result was that, once assembled, the entire installation looked resplendent, as a result of the quite intense lighting surrounded by darkness (Figure 4).



Figure 4: Ice landscape (Ana María Giuffrida).

In conclusion, we can consider that in our investigation we found that the light/dark opposition effectively produces the effect of spirituality that was sought. The void produced by the darkness allowed the lights in the film to look as if they were floating in space and in the environment, and that the space seemed to be deep. Furthermore, that the effect of spirituality produced by the selected cesias we had found in the paintings and the cinema, can be transferred to real space and real materials.

## REFERENCES

- Caivano, J. L. 1991. Cesia: a system of visual signs complementing color. *Color Research and Application* 16 (4): 258-268.
- Groupe µ. 1992. *Traité du signe visuel*. Paris: Seuil. Spanish translation, *Tratado del signo visual*. Madrid: Cátedra, 1993.
- Jofré, V. 2014. La cesía luminosa en el arte. Semiótica plástica e icónica. In: *Argencolor 2014, 11° Congreso Argentino del Color, 12-15 November, Mar del Plata, Argentina*.
- . 2017. *Aspectos de la cesía en la imagen artística*. Universidad Nacional de Córdoba, Facultad de Artes, doctoral dissertation.
- Katz, D. 1935. *The world of colour*. London: Kegan Paul, Trench, Trubner & Co.
- Tatarkiewicz, W. 2001. *Historia de seis ideas*. Madrid: Tecnos.
- Wölfflin, H. 1985. *Conceptos fundamentales de la historia del arte*. Madrid: Espasa.

# Color in the representation of homosexuality in the films *A single man*, *Blue is the warmest color*, and *Moonlight*

Pedro Felipe Pinho Souza

Universidade Estadual de Campinas, Brazil  
pedropinho88@gmail.com

## ABSTRACT

The analysis of color in the cinematographic image can be done without the knowledge about the creative processes by which the piece has passed. Through careful observation of the narrative of the film and its relation to the chromatic aspects of the image, it is possible to analyze the logic chosen for the use of a given color at each moment in the film. The important matter is to understand how the narrative determines the symbolic aspects of color and its relations with other cinematographic elements and, consequently, with other colors. This paper will seek to observe three contemporary films that bring together the theme of homosexuality, and how color is used to symbolize different situations regarding this theme. The films chosen were *A single man* (Tom Ford, 2009), *Blue is the warmest color* (Abdellatif Kechiche, 2013) and *Moonlight* (Barry Jenkins, 2016).

**Keywords:** cinema, color, homosexuality

## INTRODUCTION: THE *LOOK* AND THE COLOR OF A FILM

The *look* is the term used in cinematic industry to describe the image appearance proposed for a movie by the experts in color use. It is an aesthetic mark that highlights and characterizes the films. Through some association between color and places, characters or situations of the film narrative, the color can be loaded of symbologies, whether these are usual, cultural or historically constructed, or even different symbologies, made specifically for the piece.

The cinematic image is an element of communication between the author of the work and the public, it is not only through the sound message that the director transmits his message, the light, the shadow, the colors, the objects, the costumes, the makeup, everything which is shown on screen can carry signs and convey concepts. Concerning color, the development of symbologies related to the chromatic universe of the work is associated with the production of the *look* of the film.

During the analysis of a cinematic work, it is possible to consider the chromatic aspects as elements capable of assuming symbologies and assist the authors in the construction of the meanings that the work can acquire. There is no need to understand the creative process through

which the work has passed thought, nor to know the creator to analyze the relationship between the chromatic aspects and the film narrative.

The *look* is, then, a visual stylization in the cinematographic image resulting from an association between the narrative and usual elements, culturally or historically constructed through symbols that colors can carry. The objective of analyzing the films in this article is to find these associations and then realize the proposed *look* and thus be able to analyze the cinematographic work from color (Souza 2018).

The theme of homosexuality is recurrent in the three movies observed, it is possible to perceive in these movies how color symbolism constructions can be developed with the theme, and how the *look* is fundamental for the perception of the cinematographic images of the present time. The film *A single man* presents a palette with few blues, the images contrast shades of greys to reds and oranges. Among the three films, it is the one that presents a character with less questioning about the difficulties encountered by homosexuals. *Blue is the warmest color* and *Moonlight* brings images with a naturalistic aesthetic constructing their color symbolism through the costumes and scenarios, using especially different shades of blue. The characters in these two films have great difficulty accepting their homosexuality and being accepted by society. The color blue, in both films, is representative as a mark of this individual and social acceptance.

This text will seek to establish through colors a possible dialogue between the three films in which the reds and oranges of *A single man* are in symbolic opposition to the blues of *Blue is the warmer color* and *Moonlight*. And, also, it can make a reflection about the construction of a color symbolism that can be used as reference about the theme.

### **A SINGLE MAN, 2009, TOM FORD**

The movie tells the story of George (Colin Firth). He is a homosexual college professor and is depressed because he has just lost his mate, Jim (Matthew Goode), in a car accident. Shaken, the teacher plans to commit suicide and tries to organize everything so that his decision is not a problem for those who care about him, especially his best friend Charlotte (Julianne Moore). The film takes place throughout the day the teacher makes his decision, and it is possible to follow George's memories as the day goes on, to understand the emptiness that grips the character and his depression caused by the loss of his beloved.

The depression that engulfs the teacher and his suicide decision is marked by a grayish palette, there are few vivid and saturated colors, the scenes basically consisting of gray variations. The image without saturation is associated in the film with the idea of loss, sadness, depression and suicide. This grayish palette also marks the present time of the film, making it possible to identify and differentiate the teacher's memories that appear throughout the film. The memories are saturated, and reddish, in them Jim is alive and his presence brings saturation into George's life, so to speak.

The teacher, throughout his day, experiences different sensations, mostly associated with his routine without his late partner and associated with low saturation. However, there are times when the teacher experiences flirting and new love possibilities with other characters in his daily life. A student and a stranger show interest in George, at which time the film's color palette changes completely and instantly becoming saturated (Figure 1).



Figure 1: Sequence of the film with saturation increasing. © Frames of *A single man*, Tom Ford, 2009.

But *A single man's* embrace of chromatic stylization situates it most strongly in the digital age as a *refusal* of the natural, or rather reimagines the natural as expanded vision, incarnated in the perceptual transformations that George has undergone and that digital color has shown us. (Thompson 2015: 79)

As said, the palette is saturated in the scenes of the film's diegetic past (flashbacks), referring to George's memories in which Jim is alive, showing the happy moments of the teacher's life. Using this same palette for present times the film seek to bring references to the joy of being loved again, and the attempt to overcome the lost love, as if these new relationships could replace Jim and bring happiness back to George's life. The film opposes joy versus sadness, loneliness versus company, love versus hopelessness. This transience is marked by variation in saturation.

### **LA VIE D'ADÈLE (BLUE IS THE WARMEST COLOR), 2013, ABDELLATIF KECHICHE**

The film *Blue is the warmest color* tells the story of Adèle (Adèle Exarchopoulos), a young teenager who lives in Paris and falls in love with Emma (Léa Seydoux), a student of fine arts at a college in the same city. The *look* of the movie can be analyzed to try to understand the relationship established between these two characters.

Adèle is the main character, she will guide the viewer's perceptions. The main color to appear in virtually all production images is blue. Whether in the clothes, scenery, walls, objects, makeup, blue takes care of most of the production scenes (Figure 2). However, although the blue color involves the character, she does not always use this color in her clothing, and other colors appear during the first act of projection. The main symbolic construction established by the film is to associate the color blue with self-discovery, self-knowledge and self-love. The film succeeds in this symbology using exactly the usual and well-known association of red with platonic love for the others to oppose the self-love blue.

The character is lesbian or bisexual, and when relating to men, one may notice little blue or light blue. When Adele finds herself homosexual and falls in love with Emma, the blue color dominates the projection completely, in the scenery and clothing. Given the difficulties of adolescence and how complicated the process of acceptance in society is during this period of life, even more discovering herself bi / homosexual, one can see in several images Adèle's struggle to be accepted and as blue is used to portray situations the character will encounter. The blue color dominates the projection and the more present in the scene, the more determined the character is in finding and determining his personality and self-love.



Figure 2: Comparison between the scenes of the film, with Adèle surrounded by blue (above) and the last scene: Adèle in a blue dress, surrounded by gray (below).

© Frames of *Blue is the warmest color*, Abdellatif Kechiche, 2013.

Two interesting scenes from the movie can be observed trying to verify these associations. The first, when Adèle gets involved with Samir (Salim Kechiouche). The moment the characters begin a dance together, blue and purple lights dominate the environment and illuminate Adèle, but with the kiss between them the scene becomes reddish. The sign of change also occurs in the colors of the image, that is, when kissing Samir, Adèle betrays Emma. In this sense, it is interesting to choose the clothes of the characters in a second moment, after the betrayal, in which fight and end the relationship, Emma is wearing a blue outfit and Adèle, a gray and purple one. Gray, here again, is associated with sadness and disillusionment, and purple, a mixture of red and blue, is illustrating Adèle's confusion and division.

With the end of the relationship between the two, red is no longer so prominent throughout the end of the film, and blue no longer appears so saturated and clear. The interesting thing about the end of the movie is to see how the character, once shrouded in strong blues, comes to the presence of lighter blues and pastel colors.

In the last scenes of the movie we no longer see blues around Adèle, only grays, blacks and whites, in a possible realization that the love for Emma really is over. The visit to Emma's exhibition, the meeting with her new girlfriend and Adèle's perception of not belonging to that place are symbolized by the blue dress that the character wears. This garment amidst the almost monochromatic image suggests that Adèle will do better, accepting himself, without the need for someone to deposit his insecurities on. Despite her sadness, Adèle continues wearing blue, a



realization that the character continues her process of understanding who she is and being accepted (Figure 2, below).

### **MOONLIGHT, 2016, BARRY JEANKINS**

*Moonlight's* main character is called Chiron, however, in the first act of the movie he is called *Little*, played by Alex R. Hibbert. The beginning of the movie shows Little running away from other boys who chase him and mock him for being "different", he is then saved by Juan, known as Blue, represented by Mahershala Ali, a drug dealer, both of them live in Miami. Blue takes Little home and takes care of the boy along with his girlfriend Teresa (Janelle Monáe).

Blue meets Little's mother, Paula (Naomie Harris), who is not happy to see the boy with the drug dealer. However, Paula buys drugs with Juan and while using it, often mistreats her son. *Moonlight* has a first act full of interesting symbologies and uses of color. Just as *Blue is the hottest color*, *Moonlight* also uses blue as the color of discovering oneself and seeking to be who one wants to be. In reviewing the movie, Storey states that:

The film is pervaded by a blue-and-red color scheme that gradually blurs as Chiron as conception of himself matures. The red, it seems, pervades when Chiron or those around him hew to how others define them and actualize stereotypes. His high school tormentor sports a blood-red shirt, and his mother is bathed in red light when she shouts Chiron down before shutting her door on him to turn a trick. But when Juan tells him he must decide who he wants to be and tells Chiron that he can't let nobody make that decision for you, a Chiron is centered among a mass of blue: furniture, curtains and the sky. (Storey 2016)

In one of the most important movie scenes, Juan says a little that he cannot let anyone decide for him who he will be. This is the last scene where we see Chiron wearing red. After that, this color will appear in other characters and sets, but never in Chiron's clothes or belongings.

By observing the character's clothes, by the way, it is possible to see how the filmmakers sought to associate blue with the liberation of the character, especially in the second part of the projection. He is wearing a plaid T-shirt (blue and yellow) and he is always being portrayed between bars (as if trapped) (Figure 3, above). The idea was to turn teenager Chiron into prey for his disaffection at school. Terrel (Patrick Decile) is dressed in red. The cruel young man circles around Chiron, mocking and mistreating the young protagonist. In his revenge, however, Chiron wears blue, and walks through blue corridors, opening doors of this color as well, before flogging his disaffection. Chiron is arrested for what he did. In the scene of his arrest, when the blue light of the police car illuminates the image, Chiron has decided who he wants to be and will no longer hear the opinions of others (Figure 3, below).

"We could never at any moment forget that the man we see in the middle and end was the child we saw in the beginning" (Beachler 2017: 19). The movie shows another character looking for himself, as in *Blue is the warmest color*. Chiron is constantly surrounded by problems and deplorable situations because he is black, poor and homosexual. His self-acceptance and revolt against those who always mistreated him drives him to prison but shows his maturity. Outside the prison the character hardly uses blue anymore, only black. This shows that in jail the character hid his homosexuality. But upon meeting his friend and love, Kevin, in the final part of the movie, the character begins to accept himself again.



Figure 3: Chiron unable to leave school behind bars watches his disaffection (above). Chiron's revenge on Terrel ends up putting the character in jail (below).  
© Frames of *Moonlight*, Barry Jenkins, 2016.

During Chiron's childhood, Juan tells him that black boys turn blue in the moonlight. This statement, coupled with the narrative development of the film, shows a boy discovering and accepting himself. The last scene of the movie is therefore a way of saying that at some point one must accept one's own nature and face the world.

The theme of homosexuality is recurrent in the three works observed in this article, and it is possible to see how new symbolic constructions can be developed, and how the *look*, even if constructed through a realistic poetics, is fundamental to the perception of today's images. Unlike the last two films analyzed, *A single man* features a palette with few blues and images opposing grays to reds and oranges, the character's happiness was not in his discovery of homosexual status, nor in accepting himself in this way, but in showing his love to other. It was not self-love that would "save" George, but someone else's love. *Blue is the warmest color*, and *Moonlight* show that self-love is key.

The clash, therefore, does not revolve around the condition of an opposition between homosexuality and heterosexuality. In today's increasingly intolerant and individualistic historical and social context, the blue color in the last two films shows its symbolic strength in seeking a relationship of belonging of the characters in a society that wants them increasingly distant. The acceptance that blue brings, therefore, is not only of an individual self-love, it is not enough just to accept the homosexual condition individually, it is the collective acceptance that this blue seeks.

## ACKNOWLEDGEMENTS

Universidade Estadual de Campinas (Unicamp), Pós-graduação do Instituto de Artes  
Anna Paula Silva Gouveia

## REFERENCES

- Beachler, H. 2017. Color patterns: the production designer of *Moonlight* builds worlds that breathe with emotion. *Film Comment* (Film Society of Lincoln Center) 53 (1): 18-19.
- Souza, P. F. P. 2018. *O look no cinema digital*. Universidade Estadual de Campinas, Instituto de Artes, master dissertation.
- Storey, E. 2016. *Moonlight* uses color, characters to create excellent, carefully crafted portrait. *The Tufts Daily*, 14 November 2016. <https://tuftsdaily.com/arts/2016/11/14/moonlight-uses-color-characters-create-excellent-carefully-crafted-portrait/>. Access: 11 March 2017.
- Thompson, K. M. 2015. Falling in (to) color: Chromophilia and Tom Ford's *A single man* (2009). *The Moving Image* (University of Minnesota Press) 15 (1): 62-84.

## MOVIES

- Ford, Tom, dir. 2009. *A single man* [feature film]. Artina Films / Depth of Field / Fade to Black Productions, USA, 99 min.
- Jeankins, Barry, dir. 2016. *Moonlight* [feature film]. A24 / Plan B Entertainment / Pastel Productions, USA, 110 min.
- Kechiche, Abdellatif, dir. 2013. *La vie d'Adèle* [feature film]. Quat'sous Films / Wild Bunch / France 2 Cinéma / Scope Pictures / Radio Télévision Belge / Francophone / Vértigo Films, France, 179 min.

# Painting, landscape, cinema and color

**Leonard Echagüe**

Universidad de Buenos Aires, Facultad de Arquitectura, Diseño y Urbanismo,  
Programa de Investigación Color, Buenos Aires, Argentina  
lechague@dm.uba.ar

## ABSTRACT

This paper studies the relationships between culture, technique and religion that appear in Bruegel's Flemish paintings of the 16th century in relation to landscape, to the primitive technical artifacts and to the spatial representation of that time. For this reason, I also selected a film by Majewski that depicts that theme iconically, giving life to a painting of that time, by using the presentations of the *tableau vivants* style of the 19th century. The topics of space and time also are mentioned, as well as the problems and effects of color and light in painting and cinema.

**Keywords:** *artistic painting, cinema, Majewski, Bruegel, The mill and the cross*

## INTRODUCTION

Since the beginning of the 20th century, and from a certain wide epistemological perspective, the practices that operate with techniques of material production with the aim of creating socially meaningful objects of different type, are considered design. It is known that in the work of Peter Bruegel the Elder there are numerous references to the objects of study of that particular field of knowledge including—in this regard— technical artifacts of his time, such as clothes, landscape territories, villages, cities, illustrations, etc.

Taking a brief tour of his works we can see the degree of detail in the descriptions of objects of technical use (clocks, mills, cranes, elevators, etc.) and a new landscape treatment, where modern considerations about society (crowd, population, mass) and their behaviors (acceptances, rejections, games, dances, diverse customs) are incipiently related with the sense of the inhabited territory and with the historical changes that were taking place at that time (commodification of the land and incipient artificialization of the landscape).

This is why it can be affirmed that Bruegel and other painters of that time iconically develop in their paintings germinal concepts that anticipate what five centuries later will be part of the theories of landscape designs, urban planning and industrial objects, leaving their works as valuable elements to track the historical genealogy of these theories. Today, the landscape is part of the thought of modern design, constituting one of its objects of study. Also, landscapes, cities, graphic productions,

clothes or clothing, useful artifacts or tools and utensils of all kinds are designed technical objects that totally surround modern human life.

Technical objects are human material creations: products thereof, or their sources or their supplies. But today these technical objects are not only intended to fulfill utilitarian functions, but also affect the subjectivities of its users, for example the social status acquired by using a certain product (car, telephone, footwear, etc.). Another current circumstance is that every element that provokes attention can be considered a technical object. This has already been observed by Heidegger, who affirms that at the present time natural landscapes become industrial objects for possible hydraulic works or for tourism.

### PAINTING, TECHNIQUE AND SOCIETY

It is interesting to observe the ways of dealing pictorially with the questions of techniques and landscape in Bruegel's work, and some notable examples can be pointed out (see Klein 1978). First, the relations between technique and religion will be exposed, and secondly, we will deal with the relations between techniques and human social inclinations or values.

For the first case, the following two works by Bruegel can be mentioned: *The way to Calvary* and *The tower of Babel*, in which technical artifacts can be found in relation to religious themes. In *The way to Calvary*, the spatial position of the mill in the painting gives it a value of importance, indicating a replacement of certain spiritual aspects by technical aspects, an issue that is accentuated by the economic importance of the mill at that time (Figure 1).



Figure 1: Bruegel's painting *The way to Calvary*.

In the other work, *The tower of Babel* (Figure 2), the presence of gadgets such as cranes or 16th century elevators, illustrating a biblical reference, indicates a critical consideration of the incipient modernity, from a religious point of view, as well as the status of technique in relation to religion, an issue that the sociologist Max Weber will point out later in *The Protestant ethic and the spirit of capitalism*.



Figure 2: Bruegel's painting *The tower of Babel* (details).

For the second case, the relations between techniques and human social inclinations or cultural values, we can take Bruegel's engravings on the vices or sins and on the virtues, in which various situations related to these themes are represented, accompanied on several occasions by illustrations of technical gadgets of the time. For example, in the engraving on the gluttony, a mill with human form that appears to be an eating machine is illustrated, and in the engraving about laziness or sloth there are clocks with human parts which metaphorize the manipulation of time in laziness, not attending social rhythms (Figure 3).



Figure 3: Details of Bruegel's engravings on the vices or sins and on the virtues: *Gluttony* and *Laziness*.

Other aspects of temporality will be discussed when analyzing the film made on a Bruegel work of art, that is also the subject of this paper.

Also, for this second case we can note the paintings on village landscapes or fields occupied by groups or crowds of people summoned for some task or activity performed in those places (Figure 4). In these cases, human and natural themes are significantly approached and remain culturally integrated, a step that will allow the landscape to be a technical object, in the distant future, and a commercial territorial object, in the short term.



Figure 4: Bruegel's *Children's games* (detail).

Another technical aspect put into play by Bruegel's work is the form of spatial pictorial representation, which is manifested by the practical perspective of Flemish painting (as opposed to the Italian perspective projection, with an ideal geometric support) and uses an elevated side view forming a kind of cavalier perspective projection that gives importance to the objects and characters painted, integrated for the construction of the space of the represented landscape (Figure 5).



Figure 5: Bruegel's *Hunters in the snow winter* (detail).

Also, to give realism to the painted scene, use is made of chiaroscuro, which contributes to the three-dimensional spatial appearance of objects and characters by means of adequate shading according to the lighting received (Figure 6). Other spatial aspects will be discussed later, when analyzing the film made on a Bruegel's work of art.



Figure 6: Bruegel's *The way to Calvary* (detail); chiaroscuro effects of folds on clothes.

## PAINTING AND CINEMA

Peter Greenaway observes, in some of his films and interviews, that the expressive complexity of painting is not understood by the majority of people, who suffer from a certain “visual illiteracy”, and sets out as an example of that expressive complexity the painting *The night watch* by Rembrandt, on which he produces his film *Nightwatching*, finding and developing more than 30 keys that support a message contained in Rembrandt's painting. Similarly, although with other expressive guidelines, Lech Majewski takes a painting by Bruegel the Elder to make a film that develops the various messages expressed iconically in the work *The way to Calvary*.

Majewski's film *The mill and the cross* tries to express as faithfully as possible the cultural senses of that painting, giving life to some of its characters and establishing dynamic actions that reflect its multiple stories.

Majewski starts from an essay by Michael F. Gibson (2010) on this work by Bruegel, from which he extracts materials for the plot development of the film, in which the central characters of the story recounted by this pictorial work come alive, plus the presence of the characters of the painter himself and his patron, who commissioned the painting at that time.

The words of the painter's character are important to understand Bruegel's ideas about his work, particularly when he explains the expressive ways of his painting regarding the themes of the pictorial representation space, and the significant place of the mill in the painting.

In order to make a brief analysis of Majewski's film, the aspects related to Bruegel's expressions regarding the technique will be taken first, especially focusing on the importance of the mill on the top of a rock for the film, and later the theme of space and representation will be addressed.

The question of technique and time is mainly manifested in the film scene that Majewski denotes as the “central scene”, that takes place during four and a half minutes, from the moment 1:05:30. It shows how when the movement of the mill stops, all movements of the scene stop too, indicating a relationship between technical time and social time. We should remember that Bruegel took the clocks regulating the vital times as a reference in one of his engravings. The character representing Bruegel also notes that the detention of time has a sacred meaning that refers to the *kairos*, one of the three forms of time for the Greeks, that Christianity took as a state of divine intervention.

On the other hand, there is an interesting reference to the divine place of the mill and the miller, which indicates a replacement of the divine by the technical, adding the metaphors of the flour with which the bread of life and destiny is made, relating the technique to religion.



Regarding the theme of space and representation, it is fundamental the metaphor illustrated in the film that assimilates the visual network that is woven among the most significant and important reference events of the painting, and that encompasses and dominates significantly both the scene to be represented and the vision of the future observers of the painting (Figure 7). This is an indicator of the visual devices that structure appreciatively and geometrically the scenes (Caíno 2011). In this regard, *The Arnolfini marriage* by Van Eyck, painted one hundred thirty years before, or *Las meninas* by Velazquez, painted one hundred years later, are also remarkable.

In the center of the painted scene, where the reason for being is located, Christ is hidden in order to be preserved, as the painter's character in the film asserts; i.e., the most important thing is centrally hidden, in a similar way to Edgar Allan Poe's *The purloined letter*.

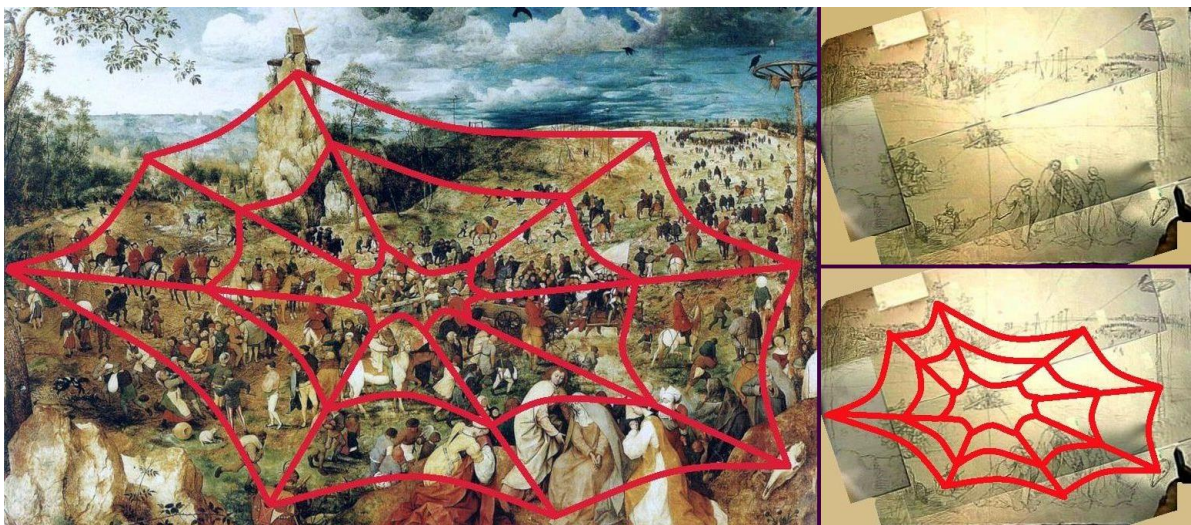

Figure 7: Spider web over the picture and over its previous drawings shown in the film.

### CINEMA, LANDSCAPE, VISION AND COLOR

In Majewski's film, the aspect of the technical realization is important. It is of high complexity, since it aesthetically composes elements of different types and origins, real, natural, virtual and pictorial, located in numerous layers of digital images for their most suitable mix, and all this as an effort to recreate the aesthetics and ideas of Bruegel on the subject he has painted, which has had an amazing result.

The composition and montage of the film is technically made by taking multiple sources of images, Bruegel's own painting, real natural scenes, real actors interacting within the blue box (or chroma key) on a blue background, and three-dimensional images of synthesis. This composition reminds 19th century *tableau vivants* (Figure 8).

In the case of natural elements, images of clouds from New Zealand sky were taken due to their elongated shape and interesting movements, as well as rock formations from the Jura Mountains in Poland. For social scenarios, houses, towns, mining installations and old mills were taken from Poland and Czech Republic (Figure 9).



Figure 8: Bruegel's painting *The way to Calvary* (detail), and its use as a virtual background in two film scenes.



Figure 9: Rock formation in the Jura Polish mountains.

The modern technical resources, allowed by the remarkable level of resolution and speed of digital cameras, as well as the high performance in the operations of montage, composition and chromatic treatment are remarkable.

Color is the fundamental variable of digital image processing both in synthesis and in the entire development of the total composition, for which the production of the film had the professional work of the cinematographic colorist Ewa Chudzik, belonging to the Polish Film Colorists Association.

Since long time ago, the chromatic treatment within the film production process is of central importance. Every film, or part of it, has a chromatic palette that is consistent with the emotional or situational climates of the scenes. But in Majewski's film, in addition, the chromatic treatment starts from the color of the clothes used by the characters, which were dyed with natural pigments from the place, in order to be faithful to those of Bruegel's painting (Figure 10).



Figure 10: Comparison of palettes between the painting and the film scene: There are eight dominant and near similar colors (Palette Generator 2019).

## ABOUT REAL, VIRTUAL, PICTORIAL AND CINEMATOGRAPHIC CESIA

Cesia refers to the effects of the real conditions in which the chromatic perception is carried out in all its complexity. For example effects caused by illumination, reflection, transparency, surface roughness, movements, neighborhoods and spatial and chromatic nearness, etc.

It can be affirmed that all real color perception involves effects of cesia. And particularly in pictorial and cinematographic works of art, there are effects of cesia; for example, in oil paintings by the details of surface finishing, or by effects of glaze with diluted layers of color placed when finishing the main figures, and in later times in cases of spatula oil painting, where expressive reliefs with the colored paste are produced. In the screening of films, the chromatic fusion between successive frames also involves these effects.

Now, when creating virtual spaces both pictorial or cinematographic, there are two qualities of cesia, one that is real and occurs in the act of perceiving the painting or film that is displayed in front of the observer, and another that is the visual representation of cesia effects that occur in the reference space of the painted or filmed work, for example in the case of chiaroscuro (Figure 6). In an interview, Majewski mentions a parallel between pictorial and cinematographic virtual lighting operations that occurs between his film and a Van Eyck painting, since technical means from different times are used to express similar religious meanings. This is specified by Van Eyck's painting *The annunciation* and by the central scene in Majewski's film above mentioned, through a illumination effect.

## CONCLUSION

In this paper we have tried to point out the overlap between cinema and painting by relating the meanings of the techniques of each time: in Bruegel's time, when modernity began and even the technique was not integrated into the culture, apart from its direct utility, and in Majewski's time, when culture depends largely on the most advanced techniques.

## ACKNOWLEDGEMENTS

This research was supported by the University of Buenos Aires, through the UBACyT project 20020170100757BA (2018-2020), based at the Color and Visual Semiotic Program, Faculty of Architecture, Design and Urbanism.

## REFERENCES

- Caíno, O. 2011. Pensar en cine (blog in Spanish). El molino y la cruz, de Lech Majewski. Online: <https://archive.is/PO66H> or <https://archive.is/km1va>.
- Gibson, M. F. 2010. *The mill and the cross: Peter Bruegel's "Way to Calvary"*. Olszanica, Poland: Bosz.
- Klein, H. A. 1978. Pieter Bruegel the Elder as a guide to 16th century technology. *Scientific American* 238 (3): 134-140.
- Palette Generator. 2019. Online color image palette generation: <https://palettegenerator.com>.

# Hybrid views: color in Brazilian landscape painting in the beginning of the 21st century

Francis Rodrigues da Silva\*, Luciana Martha Silveira

Universidade Tecnológica Federal do Paraná, Curitiba, Brazil

\* frsctba@gmail.com

## ABSTRACT

The tradition of landscape painting in Brazil was built by European traveler artists through adapted images which displayed tensions between tropical fauna and flora and human occupation shown in the 21st century paintings. Color mediates the image, building visual contradictions and harmony, including fragmentation, decollection and deterritorialization. The present article aims at showing the landscape painting development in Brazil in the 21st century by identifying how color was used in those productions, taking into consideration cultural, historical and technological aspects. To that purpose, we analyzed the production of two Brazilian artists: Luiz Zerbini and Ana Elisa Egreja, through works containing landscape hybrid and fragmented views. We used bibliographic research and image analysis methodology taking into consideration the way the artists used colors in their paintings.

**Keywords:** *painting, landscape, color, Brazil*

## INTRODUCTION

Landscape painting mediated by color has gone through changes as centuries go by. In Brazil, with painting tradition built by European travelers, landscape depicting is influenced by tropical exuberance. Visual canons, brought by the aforementioned artists, permeated the Brazilian landscape paintings with a so called scientific, picturesque and sublime view.

Past landscape depicting went through adaptations noticed even in the Brazilian landscape pictorial productions from the beginning of the 21st century. The use of color in such works helps us to recognize tensions between tropical fauna and flora as well as human mediation with its cities and architecture thus showing images were built through direct observation, photography or image edition.

The present article aims at showing the development of Brazilian 21st century landscape painting by identifying how color was used in those productions taking into consideration cultural, historical and technological aspects.

We used bibliographic research and image analysis methodologies, setting as parameter color use in the artist paintings. In the context, color dialogues with past aspects and, at the same time, points up other ways of color use through image fragmentation, decollection and deterritorialization.

In painting fragmentation is present through the graphic imagination process, including collage and superposition of elements (Denis 2002). Decollection comprehends organizational processes with fluid criteria to interweave information (García Canclini 2003: 304). Deterritorialization makes boundary, geographic territories and intercultural movements flexible thus interwoven relationship between different places (García Canclini 2003: 313).

The aforementioned processes involve the identity crisis of contemporary individual, in a period of time where communication and moving flows are intensely changing the perception of world. In Brazil, cultural processes also include political and economic crisis as well as social unevenness. Combination of fragmentation, decollection and deterritorialization, including color use in painting, change landscape image depicting.

Color perception in physical and physiological processes are linked to culture that has the role of lenses in image building and color use and in learning how to see it including socio-cultural, symbolic and psychological aspects (Silveira 2011: 121). Through culture lenses and life experiences, the human being experiences a process of learning about the visual world which interferes in the way places, people, objects and symbols are understood (Silveira 2011: 130). Similarly to what happens with color, landscape depicting in painting also go through such cultural processes of building. Thus human beings learned to see landscape thanks to culture and depicting.

Along art history, landscape painting turned out to be a genre of art depicting the relationship between man, space and nature (Cauquelin 2007). As time went by, landscape depicting took on the role of model experimentation (Mattos 2008: 11) highlighting the culture-nature-society relationship comprehending territory building and urban projects involving economic, political, scientific, technological, geographical and historical issues (Besse 2014).

Color has an important role in landscape painting and mediates different visions of the world. In the Renaissance period, *chiaroscuro* and *sfumato* promoted the feeling of space hierarchy and illusion, while in Modernism canvas surface was highlighted through color fields and gestures with paint and brush. One can understand that the use of color for landscape depicting in painting shows different characteristics in different artistic moments.

The landscape paintings show past issues visually in the beginning of the 21st century, as in Luiz Zerbini and Ana Elisa Egreja works. Nevertheless, most recent works were produced based on collage and superposition exploring the graphic imagination (Denis 2002), through space observation and the use of photography and digital processes. In those pictures we can recognize interwoven references, sometimes fragmented and sometimes recombined, thus creating hybrid glimpses of Brazilian landscape, mixing and placing different tensions (Silva 2019).

Color choices are inserted in the context of landscape depicting where we can notice visual contradictions and at the same time a search for visual harmony. The use of colors in the 21st century landscape paintings in Brazil arises from an inherited tradition and simultaneously adds other values, showing ambiguous chromatic characteristics and consequently strengthening the painting tridimensional illusion as well as propitiating visual noises. Shades, value, saturation, temperature and their contrasts are manipulated in different ways producing duality effects that join, structure and separate the different elements that are present in representations.

In the beginning of the 21st century, painting productions highlighting landscapes color is used to mediate processes that associate different image fragments helping decollection and deterritorialization as well as propitiating juxtaposition of several elements and places.

### **BRAZIL AND THE LANDSCAPE GENRE**

In Brazil, landscape depicting was mainly highlighted from the 21st century on due to the arrival of European artists taking part in scientific missions which aimed to document the American continent, that was considered exotic and exuberant. Those artists, most of them graduated from European art academies, used to depict European canon themes, composition dynamics, illusion building through planes and depth, principally interfering in atmospheric effects, using colors.

The European artist canons mediated the way they observed and painted landscapes despite there were cultural impacts of local reality and tensions (Silva 2019: 138). Artists such as Nicolas-Antoine Taunay (France, 1755-1830), who came to Brazil with the so called French Mission, suffered the aforementioned tensions (Figure 1). As Taunay was under the influence of neoclassic, Italian and Dutch paintings he found himself in a dilemma about local reality that did not fit the canons they had learned. Rio de Janeiro landscape colors did not fit Taunay's palette that indicated the Brazilian sky was artificially blue, the sun was too bright and vegetation showed excessively varied green color (Schwarcz 2008: 19).



Figure 1: Nicolas-Antoine Taunay, *Largo da Carioca*, 1816, oil on canvas, 46.5 cm × 57.4 cm.

Their way of interpreting and depicting space has defined the Brazilian landscape (Süssekind 1990: 63). Coastal region, forests, prairies, from rural to urban paintings idealized a paradisiacal Brazil. European depicting canons were adjusted to suit the geographical, historical, social, colonized and slavery Brazilian reality (Belluzzo 1994: 118).

### LUIZ ZERBINI: LANDSCAPE CONFLICT

Luiz Zerbini (Brazil, 1959) is an active artist since the 1980s decade. His artistic landscape production in the beginning of the 21st century associates nature, cities and architecture, and establishes between them opposing and cohabiting strengthening relationships (Silva 2019).

Zerbini's landscape paintings transform the canons of depicting in the traditional artistic genre. His big-sized visual paintings show excessive visual information, fragmented space topography views, nature and urban elements, simultaneously providing depth illusion and highlighting canvas surface through graphic interference patterns.

In paintings like *Law of the jungle* (Figure 2), a wide range of chromatic lines and forms are overlapped and juxtaposed depicting modern Brazilian architecture skyscrapers and improvised flower-beds evoking the term "gambiarra", that defines the mixture of different unfinished elements toward problem solving (Anjos 2017: 49).



Figure 2: Luiz Zerbini, *Law of the jungle*, 2010, acrylic on canvas, 280 cm × 346 cm.

It seems that Zerbini uses colors to build depth illusion and planes in his paintings. Nevertheless, at the same time light and shadow simulation creates spatial illusion, planes seem to be overlapped as in a collage with chromatic elements used in a plated and saturated way. *Law of the jungle* (Figure 2) depicts grid architectural structures in several colors, besides geometric interferences and sinuous forms. Those graphic and fragmented elements interfere in the depicted images creating noises.

Zerbini's production evident exuberance is not merely shown as a form of depicting through color building the luminosity and exoticism found in the Brazilian landscape (Coelho 2014), but also showing a conflict including decollection that happens between fauna, flora, architecture and discarded objects elements built by a chromatic net.

Zerbini painting exhibits the evident social unevenness existing in the 21st century Brazilian landscape, which showed uncontrolled urbanization processes and social contrasts. Cutting planes out from an abandoned space emphasizes the transitory character, desecrating its image before the artistic genre built tradition (Silva 2019), with color stressing duality between harmony and tension.

### ANA ELISA EGREJA: CONNECTING PLACES

Ana Elisa Egreja (Brazil, 1983) is an active artist since the 2000s decade, and herein we highlight her painting named *Bienal com vista para o Rio* (Figure 3), which exhibits tensions by depicting space produced by transpositions between inner and outer disconnected views joined in the painting context.



Figure 3: Ana Elisa Egreja, *Bienal com vista para o Rio*, 2014, oil on canvas, 190 cm × 250 cm.

For the painting creation process, the artist has a catalogue of images found on the internet (Mesquita and Monachesi 2013: 9), a decollection process, and then they are juxtaposed in software using graphic imagination. The result is the starting point for accomplishing her paintings which are composed of detailed environments reproducing several materials textures, decorative patterns and landscape views.

*Bienal com vista para o Rio* (Figure 3) joins Sao Paulo and Rio de Janeiro, two different Brazilian cities, providing deterritorialization. The scene foreground environment refers to Pavilhão Ciccillo Matarazzo (Ciccillo Matarazzo Pavilion), designed by the renowned architect Oscar Niemeyer (Brazil, 1907-2012), where the Bienal de São Paulo (Sao Paulo Biennial) takes place (Silva 2019). The scene decorated with wall tiles and curtains opens a window to a Rio de Janeiro beach at sunset displaying Vidigal and Dois Irmãos mountains in the background and showing the disorganized urbanization process. The scene contrasts cold and warm tones, where orange color predominates, so carrying a luminous effect integrating two different places and showing a more geometric inner environment and more organic landscape (Silva 2019).

The artist used colors to join different parts in her work and thus created light effects that integrate the scene through exploring color prevalence and harmonizing the whole painting. The existing tension between planes is softened by chromatic effects. She shows a traditional painting on canvas, using atmospheric and deep perspective, with colors meant to integrate places and provide deterritorialization, and in that way creating images that interweave spaces.



## CONCLUSION

Brazilian landscape paintings in the beginning of the 21st century show fragmentation processes with collage ideas, decollection, using varied references, and deterritorialization making evident that the image is a result of joining different places.

That type of paintings distorts the use of perspective producing anamorphosis comprising hybrid configurations where the forms are overlapped (Machado 1997). Different technologies as photography and software may be used to produce such images, consequently opening new possibilities of landscape depicting and color use.

Landscape genre in Brazil is traditional and was brought by traveler European artists, and nowadays is constantly being given new meanings. Past constructions are affected by cultural, technological and artistic aspects where the contemporary individual identity is fragmented and in crisis within intense communication and moving flows.

Images and color used herein show Brazilian culture impasses, contradictions and tensions that are evident in the landscape itself. In those hybrid views, resulting from complexes and different confrontation processes, including fragmentation, decollection and deterritorialization, color is used to join and keep apart bringing duality and instability to landscape.

## REFERENCES

- Anjos, M. 2017. *Contraditório: arte, globalização e pertencimento*. Rio de Janeiro: Cobogó.
- Belluzzo, A. M. M. 1994. *Brasil dos viajantes - A construção da paisagem*, vol. III. Sao Paulo: Metalivro; Salvador: Fundação Emílio Odebrecht.
- Besse, J. M. 2014. *O gosto do mundo: exercícios de paisagem*. Rio de Janeiro: Ed. UERJ.
- Cauquelin, A. 2007. *A invenção da paisagem*. Sao Paulo: Martins.
- Coelho, F. 2014. *Da natureza de Luiz Zerbini*. Online: <http://objetosimobjetonao.blogspot.com/2014/09/da-natureza-de-luiz-zerbini.html>.
- Denis, R. C. 2002. *Uma introdução à história do design*. Sao Paulo: Edgard Blücher.
- García Canclini, N. 2003. *Culturas híbridas: estratégias para entrar e sair da modernidade*. Sao Paulo: Editora da Universidade de São Paulo.
- Machado, A. 1997. *Pré-cinemas e pós-cinemas*. Campinas: Papirus.
- Mattos, C. V. 2008. *Goethe e Hackert: sobre a pintura de paisagem: quadros da natureza na Europa e no Brasil*. Cotia: Ateliê Editorial.
- Mesquita, T., and J. Monachesi. 2013. *Ana Elisa Igreja*. Rio de Janeiro: Cobogó.
- Schwarcz, L. M. 2008. *O sol do Brasil: Nicolas-Antoine Taunay e as desventuras dos artistas franceses na corte de d. João*. Sao Paulo: Companhia das Letras.
- Silva, F. R. 2019. *Vistas híbridas: representações da paisagem na pintura do início do século XXI no Brasil*. Mestrado em Tecnologia e Sociedade, Programa de Pós-Graduação em Tecnologia e Sociedade, Universidade Tecnológica Federal do Paraná, Curitiba, master dissertation.
- Silveira, L. M. 2011. *Introdução à teoria da cor*. Curitiba: UTFPR.
- Süssekind, F. 1990. *O Brasil não é longe daqui: o narrador, a viagem*. Sao Paulo: Companhia das Letras.

# Timelessness and temporality of landscape colours

**Malvina Arrarte-Grau**

Architect, landscape architect and colour designer, Lima, Peru  
colorarq@gmail.com

## ABSTRACT

The aim of this paper is to introduce temporality as a significant factor in the appreciation of landscape colours. The concept will serve to enrich colour intervention in sensitive environments and public spaces where culture is continually infused. The methodology for this premise starts with a general picture of the coastal landscape of Peru and its colour characteristics, followed by a brief description of the colours in the built environment. Emotionality is highlighted as a valuable resource for observing and registering temporal landscape colours. Then, a selection of ten landscape-inspired colour applications in architecture is presented, with a short outline of each project and its context. The results focus on the strategies used for achieving the respective design objectives. The observations open up new hypotheses on the transference of colours from the natural landscape into wall paint, and point out the usefulness of synaesthesia and colour naming in the design process.

**Keywords:** *coastal landscape of Peru, colour design strategies, colour naming, emotionality, paint*

## INTRODUCTION

It is established that influences from the environment condition the way we see and think about colour, starting with the adaptation of the visual system and continuing with what is apprehended from nature and the cultural domain. Natural elements seen in isolation amidst the man-made world constitute essential pieces of local identity. Certainly, the colours that take up the major part of the visual field at the urban and regional scales encompass the shades of nature in its different cycles and, even if the perception varies due to man's intervention, the basic qualities of the landscape, those determined by physical geography, remain constant.

The overall perception of nature's colours depends on life and weather patterns. As a manner of enriching the palette, superimpositions result from fixed and moving elements. From wind and surf, to a flock of flamingos, circumstantial colours spice up the scheme of the natural landscape. The recording of visual images is facilitated by temporal colours, as the focus of attention changes from what is ordinarily expected to something unusual or beautiful. With experience we learn to appreciate ephemerality. Visions, such as the luminescence of dispersed clouds, the smoothness of hills or a multicolored sun disk next to an isle, contain descriptive information that corresponds to

the material world. Additional to the data provided by colour about meteorology, physics and biology, lighting conditions generate an atmosphere identifiable with a mood which affects the viewer's emotions. Moreover, perceptions are intensified by the value that is granted to them in the psychophysiological aspect, as the landscape imbues the viewer in colour by means of necessity and comfort. On one hand the colours of natural surroundings provide variety and rest to the eyesight, whereas these may also cause boredom and fatigue.

Along the coastal landscape of Peru, parallel to the grayish-green ocean waters, the desert and the cloudy sky seem to follow a continuous linear scheme, in which humidity induces perceptual variations. In the monotony of the scenery, the temporality of natural colours is brought up as a theme, as a post-rationalization of my personal experience as architect and colour designer in Lima and the north of Peru.

### THE COASTAL LANDSCAPE OF PERU

The main geographical regions of Peru are Costa, Sierra (Andes mountains) and Selva (Amazon rainforest). The coastal region is defined by altitude: from 0 m to 500 m. It is limited by the shores of the Pacific Ocean, varying in width as the mountain foothills advance and recede. Measured as a straight line, the Peruvian coast is 2,250 km long. The surface of the coastal strip is made up of sand deposits and alluvial material shaped by action of wind and waves. Actually more than fifty rivers cut across the Andes forming narrow valleys. The proportion of forests in Peru is 60%, though most of the coastal territory is arid. The main areas of desert are located in Ica, on the central coast, and Sechura, on the northern coast. In Piura and Tumbes, towards the equator, an ecological region called Bosque Seco del Noroeste stresses in its name the rarity of rainfall.

The coast of Peru is located between latitudes 3.56° S and 18.01° S. Its linearity may be schematized as ocean, hills and sky, running parallel from Tacna, in the south, to Tumbes, in the north, coinciding in direction with the Pan-American highway. Throughout its length a white luminous sky dominates the visual field. Amidst the apparent neutrality of the colours, subtle variations in humidity are appreciated. At Sullana, close to the city of Piura, the landscape is transformed into a tropical one. The change is hard to believe.

Peru would be expected to have a tropical climate as other places of similar latitudes on the Southern Hemisphere, but due to the Humboldt Current, waters coming from the South Pole maintain a cushion of clouds over the southern and central coast, preventing precipitation. The phenomenon becomes evident as the cold current changes direction towards the west and meets warm waters coming from the Gulf of Guayaquil. As a result, moderate temperatures average 18.7°C in the southern and central coast, while in the northern part the mean temperature is 26 °C. Fog and light drizzles with an average of 3 mm occur in winter in the southern and central coast, while in the north precipitation oscillates between 50 and 200 mm. In irregular cycles the rise of sea temperature gives way to El Niño episodes, a phenomenon that causes intense rain and floods in the Andes and coastal valleys, especially in the north.

The soils of the Peruvian coast are a result of tectonic movements and weather cycles. Granite and harder materials are exposed in the south, at Moquegua and Arequipa. Further north from Paracas, visible rocks are not a common feature. On the central coast sands of a light yellowish-brown tone are seen in great extensions. Close to Lima, at Pucusana, which alludes to red (*puku*) in Quechua, the hills are reddish brown. In contrast, the hills of the north combine sands and clays of marine origin with continental sediments. Layers of fossil strata may be appreciated from the road at

several points in Talara. Soil colours in this area vary from whitish beiges, to vivid yellows, emphasized by golden light and contrasting shadows. In Lima, at Costa Verde, steep cliffs, product of a continental detachment from a past era, show protruding rounded boulders and pebbles. The 22.5 km seaside drive along Costa Verde borders pebble beaches, bluish gray at a glance, while at the shore, wet pebbles display nuances of green, reddish brown and creamy orange.

As a constant, sea waters on the southern and central coast present a grayish-green appearance, lighter near the beach and darker within the 200 miles (322 km). Further out, oceanic waters are blue. The green colour corresponds to the presence of microalgae, as part of the biological cycle that enriches the ocean with fish. The algae originate in nutrients carried by the deep waters of the Humboldt Current, which emerge to the surface. On rare occasions plankton decomposition causes water to change its colour to reddish, yellowish and brownish tones. From Paita towards the north the ocean colour is blue, though at some points sea waters may present a grayish-blue or brownish color due to river discharge.

With exception of the north during strong weather events, the greenness of native vegetation is an uncommon occurrence throughout the coast. Still, in this subtropical climate humidity causes some hills to turn green due to the apparition of plants living on fog and, in the presence of water a vast range of tree and plant species thrive. As an example, at Costa Verde in Lima until the 1970s water draining from agricultural land filtered through the cliffs allowing vegetation growth. With changes in land use this ceased, but recently an irrigation system was installed to maintain bright green and flowering *Convolvulus* and *Bougainvillea* spp. all year long. As regards agriculture, crops sustained on irrigation around river valleys include olives in Moquegua and vines in Ica, with predominance of maize, cotton, sugar cane, legumes and fruit trees. In the sunnier northern valleys of Piura and Tumbes beside the rice fields, coconuts, mangoes and lemons are cultivated. However, the proportion of farmed land on the coast in comparison to the arid territory is unquestionably low.

Last but not least comes the colour of the sky. Lima has been characterized for a boring sky referred to in literature as *donkey's belly* and *dove's chest*, alluding to its gray appearance and the sensation of oppression it causes. From May to December clouds suspended between 200 and 800 m over the coast produce diffuse light and, as a consequence, absence of shadows. Relative humidity can get as high as 85.5% near the sea in winter. Fog remains until January. Then, clearer skies last until the end of April.

Very differently, the coastal landscape of the north offers a much brighter atmosphere throughout the year. The sky is blue and the air is dry, with strong shadow effects. If precipitations occur, the desert, dotted with dusty algarrobo trees (*Prosopis pallida*) and silver evergreens, begins to transform into a vivid green landscape, as the leaves are washed and the apparently sterile terrain gets covered in herbaceous species. Few months later the dried cover on the hills shows a uniform texture and strong cesia effects (see Caivano 1997). This slowly changes to gray, as it decomposes.

## THE COLOURS OF THE BUILT ENVIRONMENT

As a consequence of the spaced cycles of rain along the coast of Peru pre-Inka vestiges could remain concealed and protected from pillage during centuries, for El Niño episodes were infrequent enough to damage the monuments only superficially, making them resemble natural features. Many platforms, temples and *huacas* (tumbs) made of mud blocks of different sizes still stand as hallmarks in the landscape and within urban land. The lines of Nazca, with hundreds of geoglyphs in the desert in Ica, are another proof of the scarcity of rain in this territory (Morrison 1978).

Construction in mud persisted through the Colony. Later, *quincha*, a technique consisting of panels made of strips of giant bamboo (*Guadua angustifolia*), covered in mud and plaster, was used for two and three-storey buildings. This was until 1940, when a major earthquake induced a change in building parameters. Since then, constructions of reinforced concrete and brick prevail. In view of the mildness of the weather along the coast, the flat roof remains as a characteristic architectural feature, and paint, as the conventional finishing material.

The use of architectural colours in Lima has been recorded since Colonial times, when pigments were imported for giving colour to the eye-straining white façades seen against the white sky. For centuries the capital was influenced by trends in building styles and colour. Moreover, as materials are transported from Lima through the Pan-American Highway with ease, tendencies reach most places along the coast. At present, because of densification and vertical growth, Lima coincides with most cities in a diminishing proportion of natural scenery in the field of vision. In this situation, thoughtful building colours may be a chance to denote sensibility towards the natural landscape.

### **EMOTIONALITY AS A RESOURCE FOR REGISTERING COLOUR**

It is not always easy to determine the emotional reaction of an individual to colour, though it is certain that moods are influenced by beauty and weather (Birren 1978: 46). A note of drama in a landscape scene may be of value to the spectator. Humidity, for instance, induces singular perceptions, as dryness in the air contributes to sharper details. A moody landscape is characterized by its striking atmosphere. Perhaps, golden light, menacing clouds, a point of receding waves or a seamless continuity between sea and sky. It is appreciated when certain elements acquire a protagonist role for their colour, or show a special brightness or *cesia*.

It seems inevitable to think about time when the outdoors is the subject of attention. The Impressionists had the urge to paint in an attempt to capture the chromatic sensation of the instant when a particular light gave life to their motifs. Photographers look for places with an unreal quality, they wait for moments when light hits every element favorably (Schulz 2012). Other forms of art, which do not necessarily depict nature, work by interpretation and intervention of natural scenery and landscape elements. The presence of colour is critical in the translation of theme into design. This applies to interior design, environmental design and architectural colour. The quest of obtaining a colour which functions by itself or next to another as observed in nature depends on the working medium, the objective and the desired level of detail. Furthermore, each colour will gain its place and proportion in space according to its inherent properties.

It requires delicate adjustments to reproduce a nuance from memory, though, unveiling a colour, its impression and meaning to the viewer, is crucial for getting the desired sensation. The emotional charge of the perception may be the subtlety that makes a nuance or colour combination succeed. The component of judgment, what is liked or disliked, is unequivocal and might make the difference for recreating a colour, as emotionality facilitates the identification of the mood as well as the refinement of the result.

### **EXAMPLES OF LANDSCAPE-INSPIRED COLOUR APPLICATIONS**

The diverse nature of the projects presented in this paper intends to show different ways in which colours inspired in the landscape were materialized into paint. The projects were done between 1990

and 2017 in Lima and the northern coast of Peru. Acrylic latex paint in matt and satin finishes was customized for each project, with few exceptions, in which enamel and automotive paint were used.

The first example was a project for Los Pulpos beach, located in Lurin, 30 km south of Lima. The houses of this resort were built on an amphitheater-shaped beach. In 1990 there was a controversial issue when two owners painted their houses in saturated colours, while the rest of the constructions displayed white and luminous colours. The objective was to put together a harmonious scheme for eighteen houses, to be executed before the next summer. It consisted of two colours for each house: one for walls and one for wooden elements. The palette included tones of medium saturation for contrast with sand and sky. The parameters considered giving a personal character to each house and maintaining a similar visual tension between adjacent houses.

The second example, of a very different character, is an oil-pumping unit in Los Organos district (north of Peru). Pumping units abound in the oil fields in Talara. These vary in size and proportions and are usually painted for protection from corrosion in black, dark green or beige by the different concessions in the area. This unit, located at 50 m from the highway, has particularly gracious proportions. To highlight its shape, the horsehead was painted in bright yellow and the counterweights in purple, while the rest of the body was painted black. Yellow and purple are present in light nuances in the desert landscape, in the soil, in the distant mountains and also, by scattering, in the sky. As a manner of associating with the surroundings the two hues, in a saturated version, were applied as if these had been *extracted* from the landscape to intensify on the structure.

The third example was done for the exterior of a house located at 300 m from the sea in front of a steep hill in Mancora (north of Peru). The former fishing village, at 4°06' S, presents an average temperature of 25° C in the cool season, and around 30° C in summer. The sky is usually clear, with nearly twelve hours of bright sunlight every day. The house had formerly been painted in an ochre yellow, which reinforced the idea of heat, by association to the soil colour (Lenclos 1990). A pale blue was proposed instead, to resemble the sky in Lima, with the intention of producing a cooling effect. This is recognizable for visitors, as *cielo de Lima* colour contrasts with the clear sky of the north.

The following example makes emphasis on the colour combination made for a house located on the beach in Mancora district. Pocitas beach is an extension of 4 km of rock pools and sand, where tides have a maximum variation of 2 m along the year. The house walls were painted in a light red-orange prepared after the reflection of the sunset sky on wet sand in low tide. The cement window jambs were painted white as the foam at the seashore, and the blinds, beige as the sand. Only when the sun is at its northernmost position on the horizon the reflection may be seen from the house.

The next example emphasizes on the procedure followed for obtaining a colour for a house interior in Mancora district from a material collected from an almost vertical slope 20 km away. The perceived colour was a very rich brown. The soil sample was sent to Lima, where the paint was prepared in a slightly more yellow and saturated nuance intending to compensate for the different quality of light. When the paint arrived to its destination in the north it still proved less intense than the desired colour. The explanation for this is that the material had been gathered from a cliff cut by machine when building the highway and, as the naturally compacted soil was exposed to dry conditions, it chipped off in coarse particles, casting strong shadows. As Lenclos would have predicted (1990: 20), shadows make the colour appear much darker than perceived at close distance, more so, on a slanted terrain. The idea of the colour could not be *transferred* by relying on the sample.

Another example of the use of soil colours was applied to a remodeled house located on a highpoint in a small bay in Pucusana district, 70 km to the south of Lima, where the colour of the soil is reddish-brown. The building appeared noticeably large in relation to the rest of the houses of the

bay. The horizontal façade displays whitish stone-clad elements amongst surfaces prepared for paint. The concept was to visually integrate the painted areas with the natural cliff by *replicating* the colour of the soil, making it dark enough to achieve a receding effect. To compensate for the distance of perception, the colour was prepared in a slightly more saturated version than the soil sample. An additional input in this project was the use of *cielo de enero*, the colour of the sky in Lima in January, on the ceilings, for blending in the interiors and the sky through the windows.

In a different context, an eclectic building of the 1910s located at a corner in Barranco, the bohemian district of Lima, was painted for enhancing the architecture. The building boasts a certain grandeur in its proportions, a variety of mouldings and white marble stairs. Actually, it houses designer shops and galleries. Four colour options were studied. Sophistication and ease of maintenance were main considerations in the decision. A grayish brown in satin finish was selected for the façade, with lighter and darker nuances for the cornices and plinth. For the friezes a very light blue-green named *resolana* (glare of the sun) was used, inspired in the sky when the sun is about to appear through the clouds. The window frames on the lateral façade were painted in pastel blue-green, surrounded by white jambs. A dark grayish blue-green, *petroleo*, was chosen for the railings.

The next example points out the colour requirement for a garden wall in a ground floor apartment in San Isidro district (Lima), in an area where the streets are lined by tipa trees (*Tipuana tipu*). The wall, topped by a wooden trellis, has a total height of 5 m and acts as a backdrop for a selection of tropical plants. A grayish blue-green was chosen in order to produce a subtle contrast with the plants, and then continue into one of the living-room walls. The colour was tested in lighter, bluer and greener versions, as to obtain the perfect depth and neutrality. The trellis was painted dark green to mimic the enveloping sensation of the trees.

The last examples bring up the colours prepared for two exhibitions presented at MALI (Museo de Arte de Lima). In 2015 nearly four hundred black-and-white photographs taken between 1917 and the 1970s were gathered for the show of Martin Chambi. The Peruvian photographer, known for his portraits of Andean culture and society, had also worked as a reporter in Peru and abroad. The pictures were framed in natural hardwood with an off-white passe-partout. A purplish blue, with a vibration close to that of the *blue hour*, reminiscent of the sky at dawn, was selected for the spaces. A small area was painted in a cream colour for breaking the continuity. The showcases were finished in a contrasting metallic red-orange, related in hue to the hardwood floor, baseboards and frames.

The final project refers to the Nazca exhibition mounted at MALI in 2017. The display included textiles, ceramics and tools made by the Nazcas, photos, projections and models of the Nazca lines, and textiles from Paracas necropolis. The pre-Inka cultures of Paracas (700 BC to 200 AD) and Nazca (10 BC to 700 AD) developed in Ica at 14° S, 260 and 446 km from Lima, respectively. Although the colours of the desert were intended to inspire the project, the selection prioritized the differentiation of spaces according to the character of the pieces. An ocher yellow, picked from a textile, was chosen for the banners and the walls of the first room. A light grayish brown, named *lobo viejo* (old sea wolf), was used for the area of ceramics, art and tools, which was the largest. *Fango* (mud), a greenish brown, was chosen for the room dedicated to the Nazca lines. And, *limbo*, a light blue-gray, was prepared for evoking a quiet atmosphere in the last room, which exhibited textiles.

## RESULTS AND DISCUSSION

The lack of chromaticity in the vastness of the coastal landscape seems to create the need for making a statement through colour. This has probably been the motivation of building owners and architects

for exploring colour alternatives for generations. On the other hand, it is undeniable that climatic differences between the north and rest of the coast offer ingredients for colour identity.

By reviewing how colours were chosen in each example, the natural scenery reveals itself as an influence. The sky and the soil proved to have been a direct inspiration for most decisions. The priority in each project, being the architectural style, comfort or fun, gave way to a design strategy. Four strategies have been defined so far: *attunement*, *replication*, *transference* and *extraction*.

In the process of colour selection *attunement* stands as a preference when different options of colour composition are evaluated to satisfy all the actors, as were the cases of Los Pulpos beach in Lurin, and the gallery in Barranco.

Project	Colour	Influential elements				Design strategy
		sky	soil	sea	other	
Beach houses (Lima)	various	x	x		x	attunement
Oil-pumping unit (north)	yellow RAL 1016		x			extraction
	purple RAL 4008	x				extraction
House (north)	<i>cielo de Lima</i>	x			x	transference
Beach house (north)	<i>sunset sky reflection</i>	x	x	x	x	transference
	<i>sand beige</i>		x			transference
	white			x		transference
Sloping cliff (north)	<i>rich brown</i>		x			transference (failed)
House in Pucusana (Lima)	<i>reddish brown soil</i>		x			replication
	<i>cielo de enero</i>	x				transference
Gallery in Barranco (Lima)	grayish brown				x	attunement
	<i>resolana</i>	x				transference
Garden wall (Lima)	grayish blue-green				x	attunement
Chambi (MALI)	<i>blue hour</i>	x				transference
Nazca (MALI)	<i>lobo viejo</i>				x	transference
	<i>fango</i>		x			transference
	<i>limbo</i>				x	transference
	ocher yellow				x	replication

Table 1: Design strategies, influential elements, and colours, as specified or named for each project.

The second strategy, *transference*, is put into effect when a colour is recognizable as it was perceived in a different location. By relying on memory the idea of a colour may be transferred from exterior to interior, from the north to the south, from an element of nature to wall paint. In this respect it is worth considering what Lois Swirnoff implies: "...colours appear different in different places, and generally do not travel well..." (2000: 2). Certainly, several adjustments may be necessary in order to accomplish the portability of colour, and ensure that colours are understood disregarding geographical distance. For the sake of the user's cultural baggage, as with the colours of the sky, designers may take licenses, demonstrating that this approach has more significance than just accomplishing a fashionable or aesthetic combination. More so, it is justified in the case of exhibition rooms, where there is a specific theme to convey.

The *replication* of an earth colour into paint proved to be a straightforward solution for integration with the setting, as realized with the house façade at Pucusana. Anyhow, distance of



perception should be considered when applying this strategy. Color appearance is influenced, not only by light and humidity but, also by the texture and cesia of the material sample, as was the case of the sloping cliff colour, which could not be transferred, nor replicated successfully.

A fourth possibility for translating nature's colours into paint is by *extraction*, as in the oil-pumping unit in the desert landscape. When a dominant hue in the setting is applied to a punctual element in a more saturated version, it fits in the scenery without deviating from the natural palette. In the case of yellow and purple, as complementary colours, successive contrasts are validated. Nevertheless, further study for other colour pairs is recommended.

On-site sample testing of paint colours and the corresponding feedback from designers and clients show that harmony, beauty and adequacy may be more important pursuits in colour decisions than exact replication. The fact that a colour may not necessarily have the precise chromatic characteristics of the landscape element which originated the idea, but still conveys the desired atmosphere and meaning, reveals that part of the colour information is processed by the viewer a posteriori for the specific situation. This happened at the Nazca exhibition, where the proposed colours were associated to the desert landscape in the context of the show. As an additional comment, regarding compositions, as observed at the beach house with a three-colour combination on the façade, more clues to place identity are offered when these are made up of various colours, than when a single color is used.

As seen in various projects, colour naming contributes to colour identification by alluding expressly to place and temporality. *Cielo de enero*, which refers to the light blue colour of Lima sky in January, well-known by locals, is an example of the conceptualization of a colour idea. In many cases, especially with earth tones, the tactile sensation gives way to colour naming. Visual-haptic synaesthesia is an advantage in this respect, as it facilitates the association of colour ideas to objects and situations (Caivano 2008).

As to conclude, it is worth to acknowledge that nature's colours are an asset to use in favor of the local environment. The appreciation of the palette offered by the coastal landscape of Peru, with its particularities and subtleties, could serve for developing colour identities and for limiting colour pollution, while finding sensible solutions for architecture and the landscape, in benefit of the user.

## REFERENCES

- Birren, F. 1978. *Color and human response*. New York: Van Nostrand Reinhold.
- Caivano, J. L. 1997. Semiotics and cesia: meanings of the spatial distribution of light. In: *Colour and psychology. From AIC Interim Meeting 96 in Gothenburg*, L. Sivik, ed. Stockholm: Scandinavian Colour Institute, Colour Report F50, 136-140.
- . 2008. Chromatic synesthesias: effects of color on the perception of different sensorial continua. In: *AIC 2008, "Colour – Effects and Affects", Proceedings of the Interim Meeting of the International Color Association*, Stockholm, 15-18 June 2008, I. Kortbawi, B. Bergström, and K. Fridell Anter, eds. Stockholm: Scandinavian Colour Institute, paper 159.
- Lenclos, J.-P., and D. Lenclos. 1990. *Les couleurs de la France: maisons et paysages*. Antony: Éditions du Moniteur.
- Morrison, T. 1978. *Pathways to the Gods, the mystery of the Nasca lines*. Lima: Andean Air Mail & Peruvian Times, Publishers.
- Schulz, A. 2012. *Architectural photography: composition, capture and digital image processing*, 2nd ed. Santa Barbara, CA: Rocky Nook.
- Swirnoff, L. 2000. *The color of cities*. New York: Mc Graw-Hill.

# Evident color and underlying color. A color constancy approach

**Alfonso de Lucas Tron**

Universidad Nacional Autónoma de México, Mexico City, Mexico  
academiadelucas@yahoo.com.mx

## ABSTRACT

In the study of color, it is important to distinguish color as a physical element in which white light decomposes into different wavelengths, and the light that impresses the eye's retina is transformed into energy of a neuronal nature that, through the optic nerve, is sent to the brain where color is actually perceived. The distinction is necessary because sunlight entering the Earth's atmosphere causes wavelengths are altered with a relative ease; vary by intensity, source location, climate, dispersion, temperature, etc. These variations cause the photosensitive cells that constantly modify the sensory impression by registering an immense amount of wavelengths. This would logically suppose that each sensory alteration could be a different object of perception. For example, a vase, seen in the intense light of noon would be *another* vase in the dim light of a sunset, since its coloration has altered over time.

In order for sensory impressions to follow the course of history, perception has a mechanism called *invariability* or *constancy of color*. It is due to the surprising wealth of values that a body can show which can be modified in time intervals by variations of light. However, perception maintains the same color pattern by providing continuity and permanence to the object perceived under changing lighting conditions. In order to achieve stability, constancy recreates an illusory effect that causes the visual object to show a flat and uniform coloration despite what the sensory impression dictates. For this purpose, we have called it evident color, typical of the look for everyday uses.

Outside the framework of constancy, there is a vast chromatic universe impossible to apprehend even though it is in *sight*. We have called this characteristic the underlying color.

Both approaches share the same visual scene; however, perception does not distinguish one property from the other because they are integrated into a *Gestalt*. The underlying color is shown in several fields such as color temperature, color in the reflection of light, color affectation by atmospheric gases, and simultaneous contrast.

We start from the thesis that perception is in the central process for the acquisition of knowledge and supports the visual education that artists have experienced; first as apprentices and then in their professional practice. Their training allows them to access the aforementioned underlying color fields, which they have explored in the following pictorial treatments: color temperature and landscape painting; reflection of light and chiaroscuro; coloration by aerial perspective and simultaneous contrast or color interaction.

The purpose is to show that perception circumscribes the vision to limits that establish the constancy of color in which the evident color is framed and beyond these limits, there are vast and complex chromatic fields where color is perceived as underlying by those who have access to the educated vision of artists.

**Keywords:** *visual perception, sensory impression, lighting, color constancy, artistic vision*

## INTRODUCTION

Visual perception has an odd peculiarity; it fosters knowledge that cannot always be explained by means of the spoken or written word. This is why images are often used to explain what happens in the depths of the psyche. Precisely for this reason and as an introduction, we will try to explain what we have called evident color and underlying color by observing the painting *The adoration of the shepherds* of the Flemish artist Peter Paul Rubens (1577-1640). We will focus on the pictorial treatment that the artist gave to the skin of some of the characters represented.

In the pictorial circle, it is known that the color of the skin is difficult to solve; thus, it is obtained from the mixture of several paintings. The *white* skin shows a *pink* hue without being *pink*; a dye that due to its obviousness and because it is captured at first impression, we call it *evident color*. The *pink* hue can be modified in numerous ways while remaining *pink*. These variants are those we will hereinafter call *underlying color*. Thus, a question remains, what does it have to do with color constancy?

To begin with, bodies usually show tonal combinations that go from the clear ones, pass through the intermediate ones and end in the dark ones. The effect of volume is achieved by the reflection of light in opaque bodies. These effects in the pictorial representation are studied by the technique of *chiaroscuro*, which consists of moving from one color to another through the application of thin layers of paint that the bodies are modeled with. Such technique was used by Rubens to resolve, among others, the face of St. Joseph without the complexion losing its pink nature. The amazing effect was possible because the painter's very fine eye could capture what we call underlying color.

The underlying color is more complex than we can imagine; so we will refer to the Rubens painting again to identify more of its peculiarities. We will also analyze the color management that the artist gave to the skins of Baby Jesus, Virgin Mary, Saint Joseph, and the shepherd at the top right of the Virgin.

In terms of lighting and as a curious fact, the Belem portal is illuminated by the light that emanates from Baby Jesus that metaphorically blesses those around him. The amazing thing is that this unique light was used by the artist to solve the skin of all the characters in the painting as the case may be. By pigmentation, by their location in areas of light (closer to the Child); by their position in the shade (hidden from the Child) or, their skin obscured by sun exposure. This way we can see that Virgin Mary has a clear hue with green and blue dyes not exposed to the sun; Saint Joseph has a burnt umber shade for being exposed to the sun rays and, the shepherd above and behind the Virgin, shows a sepia tonality precisely because it is hidden from the light. Baby Jesus' skin is the most dazzling of the picture; Rubens solved it through pink tones. Therefore, to start with the pictorial treatment of *The adoration of the shepherds*, we can see that the evident color is the pink skin tone (white) that served as a pattern for Rubens to solve the others (Figure 1).



Figure 1: Peter Paul Rubens, *The adoration of the shepherds* (1608), oil on panel, 300 × 192 cm. Chiaroscuro stimulates vision to perceive the range of colors that bodies present. The technique consists of modeling with light, medium, and dark shades through the application of thin layers of paint or glazes, as shown by the face of St. Joseph (middle). The incarnation or “flesh” color is obtained by mixing several paints and is frequently used to paint white skin (right).

Underlying color, on the other hand, is the delicate nuance that based on complex mixtures of paint, the artist used to model through chiaroscuro the qualities of white skin without divorcing the pink hue. We are referring to an amazing visual skill that the artist developed since his days as an apprentice until he established himself as one of the greatest painters of his time (Figure 2).



Figure 2: The pinkish hue of white skin (evident color) could acquire innumerable nuances (underlying color), which makes one wonder what is the color of the flesh.

### THE CONSTANCY OF COLOR

We must distinguish between color as a physical phenomenon and color as perceptual matter; although it is understood that the two are essential for the vision to take place. The physical color is manifested in the degradation of light at different wavelengths. In the Earth’s atmosphere, the wavelengths are altered with relative ease. They vary in time intervals due to factors such as intensity, source location, distance, weather conditions, albedo, dispersion, and temperature, among others. For example, the ambient light can be modified from an intense light in full sunlight to a violent diminishing by the passage of a thick cloud. In a few seconds, the lighting can differ and alter the color of the objects. For example, a vase that receives the dim light of dawn would presumably be perceived as a different object when it is seen under full sunlight. The truth is that the vision is not lost in that universe of sensations, the visual object undergoes constant changes in its appearance when it is outdoors; however, perception dictates that the body remains the same.

Man tends to see the color of familiar objects the same in diverse luminosity conditions. The owner of a blue car will continue to see it blue even in the dark, under the yellow light of the street lamp, or bathed in the glow of a red sunset. The person who is not familiar with the vehicle would hardly decide what the “true” color is shortly before it gets dark. The chromatic constancy depends on certain indications that come from memory or are related to the nature of the lighting and surrounding objects (Mueller and Rudolph 1974: 120-121).



Figure 3: The lighting modifies the coloration of bodies, but in terms of perception, the body maintains the same appearance despite these changes.

While there is light, bodies show a surprising wealth of values that can be modified from one moment to another by changes in ambient lighting. Despite this volatility, perception maintains the same color pattern in order to break the logic that each change of light corresponds to a different object. For sensory impressions to follow the course of history, perception has a peculiar mechanism called *color constancy* that acts with the sensory impression simultaneously. This provides continuity and permanence to the perceived object by balancing, stabilizing and simplifying elements of clarity and color under changing lighting conditions. Due to constancy, you can identify what you are seeing; for example, a piece of coal reflects at noon a multiple of the light that reflects a piece of plaster in the early morning; however, we perceive coal as black at noon and plaster as white at dawn (Rubinstein 1978, Arnheim 2008). It is also worth saying that a lot of snow still looks white with a lot of light or illuminated by the pale moonlight. Human vision does not perceive a *photograph* of reality; rather it looks a photographed reality.

The constancy of color shows a surprising paradox; the observer sees bodies because of reflections but does not perceive their reflective properties. It seems that the color remains unchanged with a uniform and flat appearance although the appearance of the object is constantly modified. This allows the identification of the object at the cost of an illusory effect that does not really exist. There are many qualities that “we don’t” see, but we “add” them (Müller-Freienfels 1966: 280-282). There is therefore an enormous burden of interpretation because the constancy of color is subordinate to the *Prägnanz Law*, which is a *Gestalt* principle that tends to perceive the simplest and most stable shape of all possible perceptual alternatives (Schiffman 2001: 535). The constancy of color allows us to make the following distinction (see also Table 1):

**The evident color** is innate and subjective. It results from a very complicated elaboration of sensory matter that links the object with formal properties, unifying and balancing the color for immediate identification.

**The underlying color** is huge and immeasurable. It is expressed in the three qualities of Munsell Color System: value, hue, and chroma that when combined give rise to a chromatic universe not possible to name or catalog.

Evident color	Underlying color
<ul style="list-style-type: none"> <li>● It is immediate and first impression.</li> <li>● It is typical of everyday use sight.</li> <li>● It matches shape and color, allowing a rapid identification of the object.</li> <li>● It is innate, illusory and subjective; therefore, interprets the color.</li> <li>● It is monosemic, it goes only one way.</li> <li>● It significantly reduces the appreciation of nuances, showing a uniform and plain coloring.</li> </ul>	<ul style="list-style-type: none"> <li>● It is related to the objectivity of the vision.</li> <li>● It complements the evident color in the same visual scene; however, it is not seen.</li> <li>● It has no limits and therefore cannot be apprehended by the human vision.</li> <li>● It escapes from the attention focus and seems to be hidden; however it is there.</li> <li>● It does not link shape and color, so it does not identify the object.</li> <li>● It is polysemic; it displays an immense range of features.</li> </ul>

Table 1: Differences between evident and underlying color.

The two fields are organized in the *Gestalt form* that integrates and organizes all the brain functions of which vision is part. The *Gestalt* parts from the principle that a totality is not the sum of the parts that contains them rather than being something conditioning them; or, that a part in a totality is somewhat different from what that same part is isolated or inserted in another totality. Precisely the *Gestalt* makes it difficult to distinguish the evident color from the underlying color. The underlying color permeates several fields related to visual perception, which usually escapes the common gaze and which we will now proceed to mention.

**Color temperature:** It is a faint, almost imperceptible coloration, which appears in reflections of mainly white bodies; it comes in the light and can be measured in Kelvin. Temperature has its origin in several factors of which we can mention: properties of radiant energy; by interaction of light with atmospheric gases or refraction by the passage through translucent materials. In natural environments, the color temperature is affected by the passage of sunlight through atmospheric gases, thus causing Rayleigh scattering or Mie scattering, which modify the temperature according to the weather, schedule, or season of the year.

**Color in the reflection of light:** Light follows a rectilinear course until it contacts opaque bodies; then, they absorb certain wavelengths and release others showing different colorations by reflection. Light also molds to the bodies according to their configuration recreating the effect of volume. Opacity obstructs the passage of light and reflects different levels of clarity in bright, intermediate and dark areas; but despite any shadow looks gray, it has a coloration that can escape the human eye. Obviously, the color in areas of clarity will be more eloquent than in the dark parts that just lose their chromatic properties due to the absence of light (Gómez Sánchez 2009) (Figure 4).

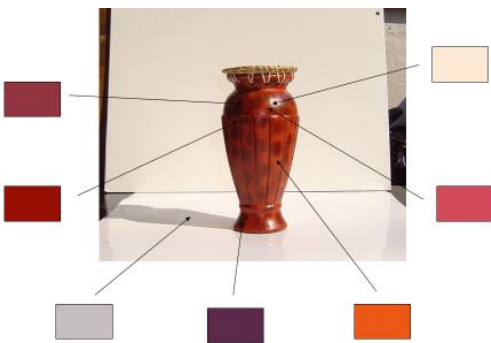

Figure 4: We do not really see every portion of the body, but we perceive a harmonious and stable mass.

**Color affectation by atmospheric gases:** Atmospheric gases modify the coloration of bodies; however, there is an important difference: the affectation by gases that are above the observer and

the affectation by gases that separate the observer from the body observed. In the first case, Rayleigh and Mie scattering are there, while, towards the horizon, the gases affect the color in a different way: there is a gradual decrease in intensity and contrast according to the distance between the object and the observer. Colors are generally mixed, blurring and losing intensity integrating a wonderful harmony that approximates the ambient temperature coloration.

**Simultaneous contrast:** Colors can only be isolated and remain unchanged under laboratory conditions (Albers 1984: 17-21). In natural environments, colors are shown in a continuous flow and amazing mosaic that is constantly transforming into generality (environment) and particularities (of each of the bodies). This mosaic has the characteristic that colors tend to interact with each other, especially with the adjacent ones, which result in illusory colors that do not exist in reality. This effect is known as *simultaneous contrast* although it is also called *color interaction*. Simultaneous means “at the same time”; simultaneous contrast therefore means that the appearance of the color may change if another color is present at the same time (Matlin and Foley 1996: 240). Rubinstein (1978: 265) defines it this way: “Simultaneous contrast is understood as an alteration of the chromatic sense produced by the proximity of two colors”. From this point of view, the changes can be polysemic, where different fields produce endless colors that do not exist in reality (Figure 5).



Figure 5: Simultaneous contrast is exemplified by this figure. The small squares that are inside the large squares are the same color; however, both seem different.

## EVIDENT COLOR AND UNDERLYING COLOR IN PICTORIAL ART

Evident color and underlying color are generated in visual perception and its field is that of color constancy. Although constancy has been studied by experimental procedures, it is a fact that artists, in their own way, have intensely explored this field, so much so that while scientists intellectualize the phenomenon, artists centuries ago have lived it intensely and expressed in their paintings.

It is possible that Rubens, like many artists, was born with certain gifts to see chromatic features that common people do not regularly see. However, it is also true that his skills evolved in training processes as an apprentice and then through the intense practice of drawing and painting.

The profession of painting allows artists to develop visual skills that go beyond the limits of color constancy, which would be impossible if perception were rigid and immovable. We speak of a flexibility that constantly processes, balances and organizes the sensory and psychic matter in order to adapt the individual to changes in the inner and outer worlds. This involves “relating perception to the general problem of cognitive development or knowledge in order to fully understand the nature of reception, acquisition, assimilation and use of knowledge” (Forgus and Melamed 2003: 11).

On this basis, the thesis that perception is in the central process for the acquisition of *cognition* or *knowledge* and therefore, supports the *visual education* through experience to see beyond the immediate impression that reaches the eyes. It is a fact that the more one “sees” the more one “knows”, since the field of perception increases with knowledge and culture (Müller-Freienfels 1966: 286).

“We can categorically state that the so-called refinement of the senses does not reside in the sharpness of the ‘sensory’ perception but in a certain capacity for mental differentiation much more complex and complicated and, of course, distinct from the sensory function.” The artist sees the world in a notoriously different way than common people see it. “The so-called refinement of the senses is actually a refinement of the psychic faculties” (Müller-Freienfels 1966: 273-275).

Visual education is the means by which artists have explored the underlying color. The formation must necessarily go through a prolonged process so that the underlying color is understandable in the form of evident color, only then will the sensory matter be apprehendable to the human intellect and can be used for very specialized purposes such as drawing and painting (Figure 6).

In this sense, artists in their own way have explored the aforementioned fields of the underlying color in the following terms.



Figure 6:  
From evident to underlying color,  
through visual education.

**Color temperature and landscape painting:** Leonardo da Vinci (1964) observed that the figure should not be separated from the surrounding atmosphere. Paul Westheim (1973: 26) observes: “For the genuine colorist the atmosphere and the figure form an indivisible unity.” The observation is timely because the environment determines albedo as well as temperature coloring. Unlike the studio painting where you have better control of light, when outdoors or landscape painting the artist must seriously consider the prevailing lighting conditions. For this purpose, they require an ability to perceive the subtle or abrupt changes, either at different times of the day, for the seasons and for various climates, since the temperature directly affects the coloration both in general and in particular (Figure 7).

**Reflection of light and chiaroscuro:** Light, when making contact with opaque bodies, adapts to their configuration recreating different qualities of luminosity according to the obstruction of the passage of light. In the artistic field, *chiaroscuro* (from Italian, light and dark) is called the discipline that precisely studies the qualities of reflections from which the effect of volume on flat surfaces is obtained. It comes from the appearance of objects that is unstable due to variations in direction, quantity and quality of the light they receive. Chiaroscuro studies the levels of clarity, halftones and monochrome and polychrome darkness that show different parts of the body that in its entirety provides the effect called “local color”. Reflection coloring is obtained by the application of fine glazes that produce a third color by transparency, which is the mixture of the layer above and below. This is a procedure that allows to regulate the transition from one color to another, which gives a third dimension impression. Although this technique seems to be simple, it is very complex. Leonardo da Vinci said: “It is more difficult to shade a figure than to draw the contours of it; modeling requires reflection and long study.” (Figure 8).

**Coloration by aerial perspective:** Perspective can be approached from two standpoints: linear and optical; in both cases there are decreases that are accentuated as the distance between the object and the observer increases. The linear perspective is based on geometric foundations of the



projection of the light beams inside the eyeball. Visual cones cause close objects look larger and, in contrast, will be smaller as the viewing angle is reduced. On the other hand, in the optical perspective or aerial perspective, the decreases go in the direction of the interposition of air between the observer and the object being looked at. Interposition causes chromatic effects of nearness and distance; for example, warm colors among which red, vermilion or roasted sienas are typical of proximity and in the distance are diluted or lost. On the other hand, in close proximity, cold or warm colors are more vibrant and contrasting; although white and black are intense, they turn pale and gray. As the distance increases, the colors dissolve and mix while they clear up as they move away to the horizon. Distance provides a very interesting effect; the colors approach the ambient temperature, an effect that can be observed in the hills or distant mountains (Figure 9).

**Simultaneous contrast or color interaction:** In the second half of the nineteenth century, an artistic movement that gained strength in open rebellion with the traditional procedure based on the transition from one color to another through glazes (chiaroscuro), decided to experiment with the application of pure or almost pure colors, just from the bottle. With this innovative procedure, intense color vibration was achieved as if the scene just captured the impression of a moment, giving rise to the movement called Impressionism (Crespelle 1990). This pictorial tendency replaced the glazes with the juxtaposition of colors and resulted in surprising coloring and great luminosity. Juxtaposition causes two or more colors to interact; that is, one influences another resulting in a third color that does not really exist and it is really an illusory effect. This effect had been described by Leonardo da Vinci (1964: 178): “The color of flesh pales on a red background. The skin reddens on a yellow background; the colors seem different depending on the background changes.”

The scientific background is found in the works of Chevreul (1786-1889) who developed the concept of simultaneous contrast of colors, which the pointillists later resumed, which output was a scientific vision of art. These artists worked with small spots of color whose purity caused a chromatic saturation that made the painting vibrate.

The simultaneous contrast is taken up by Josef Albers who started from the thesis that “In visual perception you hardly see a color as it is in reality, as it is physically” (Albers 1984: 13).” The creation of “non-existent” colors take us to the grounds of illusion where recreating countless colors with a limited palette is possible. He takes into account the field theory as a dynamic whole; as a system in which the alteration of any of the parts affects all others (Figure 10).



Figure 7: Jacob Izaacksz van Ruysdael (i.1628-1682) *The windmill at Wijk bij Duurstede* (1670).



Figure 8: Michelangelo Merisi da Caravaggio (1571-1610). *The crucifixion of Saint Peter* (1601).



Figure 9: Carlos de Haes (1826-1898)  
*The Mancorbo pass.*



Figure 10: Camille Pissarro. *Spring, blooming plums, Pontoise* (1877). Musée d'Orsay, Paris.

## CONCLUSIONS

Although the evident color limits vision, the paradox is that the underlying color is present in every visual scene before our eyes even though it is not *visible*. There are no devices to unravel the mysteries of underlying color. Even if you look closely at a reliable and meticulous photographic image, it will necessarily have to go through the color constancy filter. The only means by which the underlying color can be accessed is through visual education that, beyond artistic purposes, is a fertile field for color research from scientific approaches. For all this and more, Albers' maxim gets to the point: "Color is the most relative of the means used by art."

## REFERENCES

- Albers, J. 1984. *La interacción del color*, Spanish translation by M. L. Balseiro. Madrid: Alianza.
- Arnheim, R. 2008. *Arte y percepción visual*. Madrid: Alianza.
- Crespelle, J.-P. 1990. *La época de los impresionistas*. Buenos Aires: Vergara.
- Forgus, R. H., and L. E. Melamed. 2003. *Percepción. Estudio del desarrollo cognoscitivo*. Mexico: Trillas.
- Gómez Sánchez, D. 2009. *Sombra iluminada*. Ediciones de la Universidad de Castilla-La Mancha.
- Leonardo da Vinci. 1964. *Tratado de la pintura*. Madrid: Espasa-Calpe.
- Mattlin, M. W., and H. J. Foley. 1996. *Sensación y percepción*. Mexico: Prentice Hall.
- Mueller, C. G., and M. Rudolph. 1974. *Luz y visión*. Mexico: Colección Científica de Time-Life.
- Müller-Freienfels, R. 1966. *Tu alma y la ajena. Una psicología práctica para todos*. Barcelona: Labor.
- Rubinstein, J. L. 1978. *Principios de psicología general*. Mexico: Grijalbo.
- Schiffman, H. R. 2001. *La percepción sensorial*. Mexico: Limusa.
- Westheim, P. 1973. *Mundo y vida de grandes artistas*. Mexico: Ediciones Era.

# Designers' experience and use of colour information

Gyeonghwa Lee\*, Vien Cheung, Tang Tang, Stephen Westland

School of Design, University of Leeds, UK

\* ml13g3l@leeds.ac.uk

## ABSTRACT

To effectively encourage and guide designers to make a use of colours in real-world products, it is necessary to know how designers currently use colour information while dealing with actual colours for such products. Email interviews, online surveys and colour application/modification experiments were carried out with 27 designers with different levels of design experience. In an initial phase four phenomena that designers heavily rely on for colour information application in real-world design, when they have little other information about design tasks, were discovered: personal factors, previous design experience, basic knowledge about colour and design, and common sense. The overall positive/negative perception of colour information, colour information formats and sources that designers used and their preferences, the quality and accessibility of colour information was also investigated during a secondary colour modification task. This preliminary study was conducted as a part of ongoing research for the development of a colour communication and design tool for designers.

**Keywords:** *colour information, designers, real-world colour application*

## INTRODUCTION

Colours are widely used in most design areas. Ideas are subject to visualisation by designers and then expressed through compositions which are composed of shapes supplemented by colour schemes (Wong 1997). Designers are motivated by images and colours (Lofthouse 2006). For them, colour is usually, not only the most important but, the fundamental design element to convey information regardless of the designers' domain area (Lee et al. 2017).

Various scholars (Fricke 1996, Liikkanen and Perttula 2009, Ozkan and Dogan 2013, Vallet et al. 2013, Goldschmidt and Rodgers 2013, Deininger et al. 2017) have made efforts to discover the distinctive characteristics of design ability by level of design experience from different design areas such as engineering design, architecture design, textile design, eco design, and cognitive science and so on. However, we do not actually know how different designers deal with colour information or utilise their design knowledge and experience in order to apply colours in real-world information

contexts. As design outcomes can be regarded as the final decisions made by designers (Ahmed et al. 2003), it is expected that an investigation of designers' decisions during actual colour application/modification or colour information use would reveal what further information and resources need to be provided to them in order to change their colour use behaviour.

This research therefore addresses the following questions:

- How do designers deal with colours if they have limited knowledge about actual information users and product formats on which colours need to be used?
- Where do designers search for further colour information?
- How do designers perceive colour information that they seek during the colour tasks?
- What is the level of overall satisfaction among designers about the quality of the colour information that they find and use?

This study has been conducted as a preliminary piece of research in order to subsequently change designers' colour-using behaviour by offering a designer-friendly colour-communication tool at the end of a wider colour communication and design project. The study involves 27 designers, comprising 9 designers from each of 3 groups: expert designers (with 9.5 years of work experience), novice designers (with 2.5 years of work experience), and student designers (with no work experience).

## METHODS

The main purpose of the study is to investigate the actual experience of designers of colour information use, and real world application/modification of colour by designers. However, it is primarily the former aspect of the research that is analysed and described in this paper.

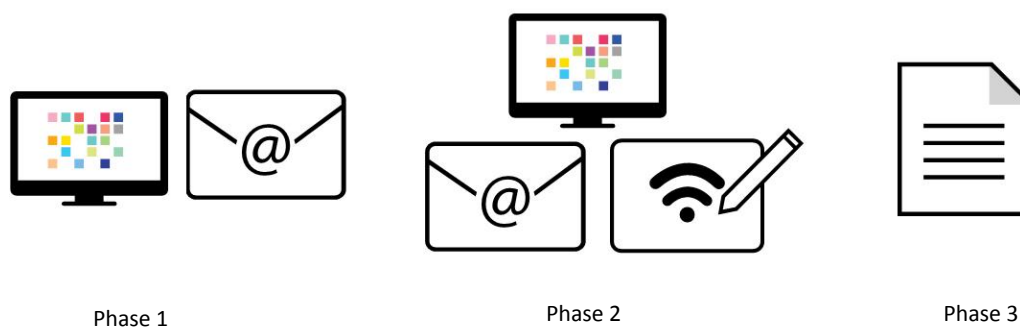

Figure 1: Overall experimental process of this research.

The whole process of the study of designers involves three stages (Figure 1). It is comprised of an initial phase (colour application experiments and individual email interviews), secondary phase (colour modification experiments, secondary individual email interviews, and online survey) and a third phase (a self-reflection report). During the task in the initial phase, little information was offered to design participants in order to explore the usual way they use colour information and colour application behaviour. For the secondary colour modification experiments, participants were offered user information for consideration, to be taken into account also in the secondary interviews and online survey. During this stage, user data (in this context information about age-related cataracts and their effect among older people) was shown to designers. This data comprised an image with a question in order to inspire design participants to think about the users' position and

ask them to search for relevant colour information to address the difficulties that users faced. In the final phase, designers were asked to compare previous tasks by writing reflections in order to find out how they deal with data on colour and colour information.

## RESULTS AND DISCUSSION

In the initial design task, the participants were asked to apply colours on pre-formatted proposed design artefacts (using Adobe Illustrator). After this their colour-information use behaviour was investigated through email interviews. In total, more than two-thirds of designers (19 out of 27) did not try to search for any information for colours during the initial colour task.

Table 1 summarises designers' responses regarding their own colour information resources for the initial colour application task (phase 1) if they did not use any external or additional resources. The responses can be categorized into four types: personal factors, previous experience of projects or design, basic knowledge of colour and design, and finally common sense. All designers are likely to depend on personal factors such as instinct, design sensibilities, preferences, and feelings.

Level of designer	Number of mentions	Categories of colour information source (examples in quotation)
Experienced designers	5	<b>Personal factor</b> "Instinct" "Personal choice based solely on the designs" "Design sensibilities (personal)" "Personal colour sensibility and colour preference"
	4	<b>Experience</b> "Previous experience" "Accumulated design data from design project" "Similar design experience from a past design project"
	2	<b>Knowledge</b> "Basic (general) knowledge of the design and colour"
Novice designers	4	<b>Personal factor</b> "Personal instinct" "Personal drawing experience"
	3	<b>Knowledge</b> "Basic knowledge about colour match, association"
	1	<b>Common sense</b> "Common sense"
Student designers	8	<b>Personal factor</b> "Instinct" "Previous experience" "Personal experience and feeling" "Personal preference"
	4	<b>Knowledge</b> "Design knowledge (colour and layout)"
	1	<b>Common sense</b> "Common sense"

Table 1: Colour information resource factors by designer groups from phase 1.

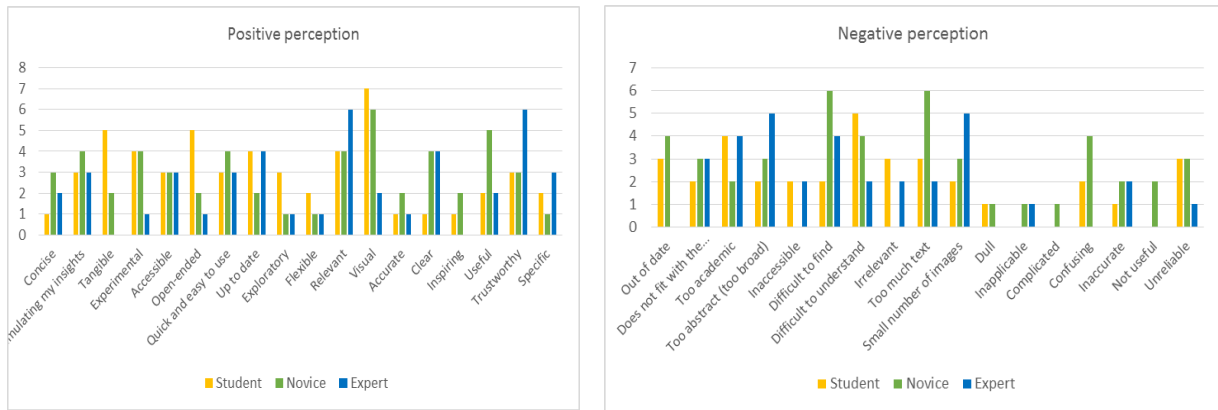

Figure 2: Overall positive and negative perception of colour information found during the colour information use and colour application task.

Figure 2 illustrates overall positive and negative perceptions of colour information provision they looked for by the three groups of designers during the colour modification task (phase 2).

In terms of positive values, the most frequently selected word was ‘visual’ by the student and novice designers, although it was not highly selected by those in the expert group. This suggests that student and novice designers searched for (or preferred to use) visual information such as images, colours, or pictures during the task more than the expert designer group. The words that only expert designers selected frequently were ‘specific’, ‘trustworthy’, ‘relevant’. This is probably due to their higher level of personal confidence in their own task-related information searching abilities.

In terms of negative perceptions, the most frequently selected terms by all groups were ‘difficult to find’ (12 out of 27), ‘difficult to understand / too much text’ (each 11 out of 27), ‘small numbers of images / too academic / too abstract’ (each 10 out of 27). These are the negative perceptions of colour information that designers highlight when seeking such information.

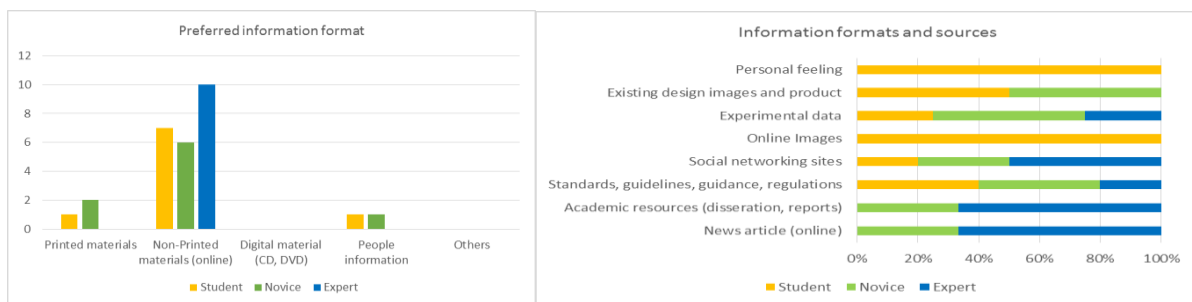

Figure 3: Preferred information formats, formats used, and sources during colour information searches (phase 2).

As for preferred information sources expressed in phase 2 (Figure 3), all expert designers would prefer to use online information. One of the experienced designers said that “information online is the easiest to access from any location” during the email interview. However, in addition to this, other groups would like also to be able to obtain information from other people or printed materials. A novice designer answered that “as people take in information in different ways, ... through friends/co-workers or at a conference, generally people will be more interested and take it on board as it can be more interactive.” It is clear that although all participants would want to use the internet regardless of their level of experience, it also needs to be acknowledged that information from other people or printed paper can be good resources.

When we compare the actual formats used for searching for colour information, more experienced designers tend to use relatively objective resources, such as news articles or academic publications. Less experienced designers tend to use personal subjective feelings or search for colour information in order to apply colours in real world information formats or find an existing physical design product or online images to extract colours and apply them.

Nevertheless, there is a common factor that all groups of designers use social media (for example, YouTube, Instagram, Pinterest, personal blogs) in order to look for colour information. The common characteristics of these sites are that they are supposed to have a visual focus with photos or videos, and be interactive. Designers may want to receive the colour data in this dynamic way.

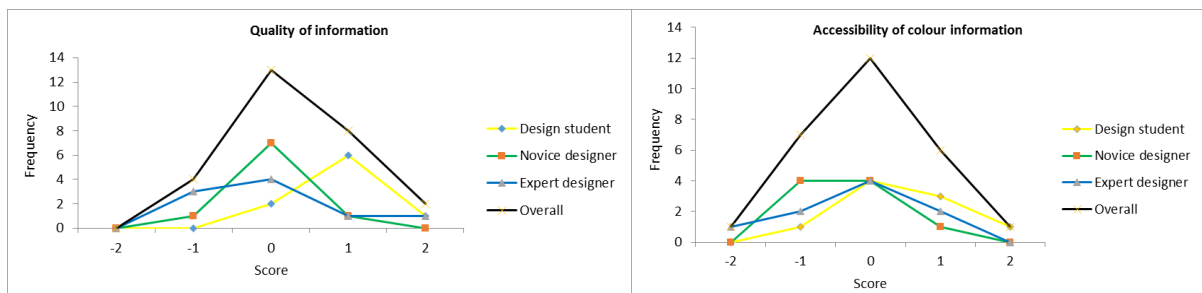

Figure 4: Overall satisfaction with the quality of information that designers found and used during the task (left); ease of finding information used for the colour application/modification test (right) in phase 2.

Figure 4 shows the overall satisfaction at the quality of information and ease of accessibility of the information during the colour application/modification task. A 5-point Likert scale that ranged from very satisfied (2) to very disappointed (-2) was used to estimate their overall satisfaction. There is not a big difference between the overall quality of information (left) and ease of accessibility of the information (right) for the colour tasks. This data could be interpreted as showing that ease of accessibility is related to the overall satisfaction with the quality of the information.

Level of designer	Statements (quotation)
Student designers	"Finding reliable information was difficult" "Limited resources and knowledge about colours and users"
Novice designers	"Not enough information about colour perception and hard to tell whether the information found correlates to all individuals or not" "It is hard to find some visual examples"
Expert designers	"Research was not conclusive, and so it wasn't clear what the action should be" "The effect of cataracts on perception of colour was not covered in much detail by my chosen information sources. By comparison, the effect of cataracts on sharpness/blurriness was always covered in more detail and always accompanied by example images"

Table 2: Comments on difficulties while finding and using colour information during the colour design tasks.

Feedback on the colour information use during the colour design tasks from each group of designers is given in Table 2. The table summarises that poor information reliability, lack of colour information related to users, lack of visual examples (as designers are motivated by images and colours), unclear information for the effective use of colours are common difficulties.

## CONCLUSIONS

To conclude, the colour information that is currently available for designers to search and use for actual colour design (colour application/modification tasks) may be unsuitable for them. Because of this, regardless of level of design experience, it appears that designers rely on subjective factors that were revealed: personal intuitive/insight/preference, colour and design knowledge, design experiences and common sense. The designers' positive/negative perception of information sources and formats for colour information was investigated in terms of designer group. The overall quality of present colour information was not rated highly by any groups of designers. This may be related to the accessibility of information about colour. From their feedback on the colour design task (phase 2), designers would want to know about reliability of information, and for information to be easy to access (easy to find), and to be concise, conclusive, and visual.

These findings during the colour information use and colour design tasks need to be considered to develop the designer friendly colour design and communication tool for further research. Also the quantitative colour data gathered during the colour application/modification tasks needs to be interpreted and compared to the qualitative responses from designers in the next stage of the study.

## REFERENCES

- Ahmed, S., K. M. Wallace, and L. T. Blessing. 2003. Understanding the differences between how novice and experienced designers approach design tasks. *Research in Engineering Design* 14 (1): 1-11.
- Deininger, M., S. R. Daly, K. H. Sienko, and J. C. Lee. 2017. Novice designers' use of prototypes in engineering design. *Design Studies* 51: 25-65.
- Fricke, G. 1996. Successful individual approaches in engineering design. *Research in Engineering Design* 8 (3): 151-165.
- Goldschmidt, G., and P. A. Rodgers. 2013. The design thinking approaches of three different groups of designers based on self-reports. *Design Studies* 34 (4): 454-471.
- Lee, G., S. Westland, B. Matthews, and V. Cheung. 2017. Designers perspective colour as a catalyst for improving accessibility. In: *AIC 2017, 13th Congress of the International Colour Association, "Being Color With Health", Proceedings*, Jeju, Korea, 16-20 October 2017. Seoul: Korean Society of Color Studies.
- Liikkanen, L. A., and M. Perttula. 2009. Exploring problem decomposition in conceptual design among novice designers. *Design Studies* 30 (1): 38-59.
- Lofthouse, V. A. 2006. Ecodesign tools for designers: defining the requirements. *Journal of Cleaner Production* 14 (15-16): 1386-1395.
- Ozkan, O., and F. Dogan. 2013. Cognitive strategies of analogical reasoning in design: Differences between expert and novice designers. *Design Studies* 34 (2): 161-192.
- Vallet, F., B. Eynard, D. Millet, S. G. Mahut, B. Tyl, and G. Bertolucci. 2013. Using eco-design tools: An overview of experts' practices. *Design Studies* 34 (3): 345-377.
- Wong, W. 1997. *Principles of color design*. New York: John Wiley & Sons.



## Color and landscape in textile design

Gabriela Nirino<sup>a\*</sup>, Cecilia Dorado<sup>b</sup>, Daniela Tosar<sup>a</sup>, Julia Feldman<sup>c</sup>, Josefina Alvarez Gardiol<sup>c</sup>

<sup>a</sup> Universidad de Buenos Aires, and Universidad Nacional de Lanús, Argentina

<sup>b</sup> Universidad Nacional de Lanús, Argentina

<sup>c</sup> Universidad de Buenos Aires, Argentina

\* gabinirino@hotmail.com

### ABSTRACT

Color is a meaningful aspect of a textile product. At the Textile Design degree, we are interested in promoting a textile design that carries a sense of identity that is meaningful to designers and users. The aim of this paper is to share the strategies developed through the different levels of the Textile Design degree to find, select and use color as a meaningful aspect of the projects. These strategies involve different types of approaches: surveys and interviews, bibliographic research, trends research, dye and painting materials experimentation, digital processes, collection of materials, production of sample books and color palettes of textile elements and products. All the exercises involve the use of color as a fundamental part of the product system. Color comes from the personal, urban or natural landscape.

**Keywords:** *textile design, color education*

### TRENDS AND COMMERCIAL CONSIDERATIONS

In those exercises aimed at preparing the student for the industrial work, the chromatic decision is made at the end of the process according to commercial considerations.

We work in a traditional way, following the international fashion trends and adapting them to the requirements of our market and customers. The sequence of the process consists of a series of adaptations from general trends to the selection of color for a product of a specific season, sector (like upholstery, footwear or underwear), brand and audience.

The following activities are included:

- searching of international trends on-line or in professional publications,
- creation of a general color palette according to the season,
- selection of a specific palette for a sector (includes classic colors for that sector, colors of one or several brands in particular, colors according to fashion trends),
- choice of color palettes for a particular product (Figure 1).

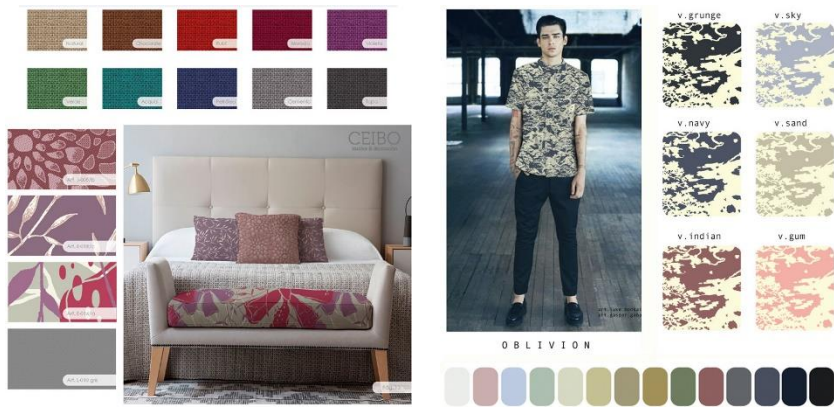

Figure 1: Color palettes. Upholstery collection by Florencia Lois (left), and Fashion collection by Victoria Asato (right).

## PERSONAL APPROACH

In this case, the goal is for the student to use color without the preconceptions associated with them (red = passion, for example). They explore their feelings, memories and associations in relation to a particular color, and create a color book that includes drawings, texts, tangible materials. They explore different representation techniques and a variety of materialization formats, from the traditional paper book to the creation of digital sites (Figure 2).



Figure 2: Color books (details) by Laura Sakowicz, Denise Clain-Domenget and Lucía Cordon Larios.

## PERCEPTION AND EXPERIENCE OF USERS AND CONSUMERS

The meaning of *design* and the scope of the designer's activity have been expanded in recent years. Following Guy Bonsiepe (2013), the understanding of users and consumers needs seems fundamental to us.

The main feature of design is the approach: at the center of design is the interaction between users and material and semiotic artifacts. It is the only profession that focuses on use—which is much more than usability—developing concrete proposals to improve the relationship between artifact and users. (Bonsiepe 2013, our translation)

To better understand the user's perception regarding color, surveys and observations are carried out as part of the work of selecting colors and tones. The objective is to obtain relevant information for the selection of color associated with users' feelings and preferences, not only about a color but about a color used in a specific product made with a certain material.

## **CULTURAL ASPECTS: COLOR AS IDENTITY**

In some of the exercises, the objective of the use of color is to recover a space for reflection on the symbolic aspects of color, typical of the students' personal and national culture, partly lost owing to the commercial importance attributed to international trends and homogeneity that this produces in the color experience.

The work methodology involves determining an identity code of a geographical area (region, city, area of the city): iconographic elements, natural elements, architectural details, characters of the site, products or typical materials, sounds and of course colors. The students have to obtain the information visiting the place to produce a meaningful corpus of material. The visual record is done through photographs, drawings or paintings, and color scanner apps.

## **MATERIALITY**

There is an economic value related to color: the labor, capital and knowledge involved in dyeing, painting and printing a textile. Also, the perception and use of color varies according to the material substrate. A colored material is the result of a complex process, which involves economic, technological and cultural aspects.

In order for the student to understand these aspects, dyeing and printing tests are performed. They experiment with both synthetic and natural dyes; in the latter case they explore various sources of color and produce the dye. The results are several catalogs of yarn and fabric samples dyed and printed with various methods.

## **SYMBOLIC VALUE**

Finally, exercises are carried out whose objective is to understand the symbolic value of color at certain times, cultures or artistic movements. The activities include bibliographic research and the survey of everyday objects, architecture, artistic works and graphic work, in order to create a representative iconographic repertoire, which includes color palettes for different uses.

## **CONCLUSION**

Systematic work on color has always been helpful and its benefits are verified in the quality of textile design projects. We find particularly important to use tools that allow the student to acquire autonomy in their work. Color is a fundamental part of the product system; understanding the symbolic, technical, productive and material aspects enriches the design activity. It also promotes a reflexive attitude that exceeds the copy of global trends and allows generating a work with its own identity.

## **REFERENCE**

Bonsiepe, G. 2013. Sobre la aceleración del período de semi-desintegración de los planes de estudio de diseño. Lecture delivered at the 6th ELADDI (Encuentro Latinoamericano de Docentes de Diseño), July 12, 2013, Oberá, Misiones, Argentina. Available online: [www.guibonsiepe.com/wp-content/uploads/2019/04/Conferencia-2013-ELADDI-para-red-rev.pdf](http://www.guibonsiepe.com/wp-content/uploads/2019/04/Conferencia-2013-ELADDI-para-red-rev.pdf).

# The role of colour in a successful logo

Ahmed Nasseraldin\*, Stephen Westland, Jamie Marsden

University of Leeds, UK

\* sdakn@leeds.ac.uk

## ABSTRACT

This research is concerned with the role of aesthetics and its importance in the design and success of corporate logos. The specific interest is in visual aesthetics; that is, how the logo looks without reference to the context in which the logo is applied or the brand or company that it represents. Aspects of visual aesthetics includes colour and form. This study aims to ascertain the feature space in which consumers evaluate the visual appearance of logos and to determine the role and importance of colour in this feature space. In this work, therefore, a psychophysical scaling experiment is described to measure consumers' responses to visual attributes of logos. A total of 50 logos were evaluated by 22 participants in terms of 10 visual attributes (complex, proportional, unique, familiar, memorable, colourful, feminine, bold, friendly and modern). During the experiment each participant was presented with one of the logos and asked to respond to each of the 10 attributes in turn. Responses were collected in the form of a 5-point Likert scale. Colourfulness was shown to have statistically significant positive correlations with the following attributes: friendly ( $p < 0.001$ ), feminine ( $p < 0.001$ ), bold ( $p = 0.022$ ), modern ( $p = 0.036$ ), unique ( $p = 0.003$ ) and memorable ( $p = 0.036$ ). Correlations between other attributes were also found, suggesting that some reduction in dimensionality of the feature space may be possible using factor analysis.

**Keywords:** *colour, aesthetics, visual communication, art and design, logo design*

## INTRODUCTION

Logos are a visual cue that can help companies to communicate their identity and capture consumer attention (Kim and Lim 2019). The importance of understanding how a logo is perceived is by consumers is therefore increasing (Phan 2009). The term interactive aesthetics can be used to describe the more general aesthetics that exists for a real logo in a real-world application (for example, a logo may be visually appealing but that appeal may not be so strong for a logo that represents a brand that is perceived negatively by the public).

Colour is considered to be a powerful visual cue (Riezebos 2003) and can be the most commonly used feature in image retrieval (Henderson and Cote 1998). Colour is sometimes referred to as a silent salesperson (Eiseman 2000), but how important is colour compared with other visual attributes of logos? How important, for example, is colour compared with, say, symmetry (Bettels and Wiedmann 2019). Indeed, what are the visual attributes of logos that are important to consumers and that may contribute to the success of a logo? This study therefore sets out to ascertain the feature space in which consumers evaluate the visual appearance of logos. The starting point for this is a scaling experiment to explore consumer response on a range of attributes.

## EXPERIMENTS

A total of 50 images of logos were obtained. The logos were selected from a list of global brands to represent four industries and covered a number of categories including electronics/communication, food and beverage, energy, automotive, entertainment and education. The list of the logos used can be seen in Table 1. An online questionnaire was designed to capture the attitudes of a group of 22 participants (6 males, 16 females; aged 18-44) towards each of the logos. Of the 22 participants there were 8 from China, 4 from Saudi Arabia, 2 from USA, 1 from UK and 7 other. Although the questionnaire was available online, each of the 22 participants completed the questionnaire in the same room and under the same conditions to avoid the additional problems that can result from online studies of this type (for example, wide variations in viewing conditions and variability of viewing devices used). During the experiment each participant was presented with one of the logos and asked to respond to 10 attributes. The ten attributes were complex, proportional, unique, familiar, memorable, colourful, feminine, bold, friendly and modern and the participants were asked to indicate the extent to which the logo was associated with these attributes using a 5-point Likert scale (with the labels extremely, very, moderately, slightly, and not at all). This was repeated for each logo that was presented to each participant in random order. The total number of data points collected was 11000 (50 images × 22 participants × 10 attributes). The attributes were chosen to represent the views that participants are likely to have about the logos.

For the analysis the Likert responses were assigned the numbers 1-5 (where 1 was not at all and 5 was extremely). These data were treated as interval data. There is much literature about the merits of treating categorical data from Likert experiments as interval data but no general consensus as to whether it is reasonable to do so (Jamieson 2004, Norman 2010). The raw Likert values were averaged over all participants to produce a mean scale value for each logo and for each attribute. Mean scale values for attributes were compared using the coefficient of determination ( $r^2$ ).

In a subsequent study the scale values of the attributes will be used in a factor analysis to discover a low-dimensional feature-space that captures the attributes that participants evaluate logos using. However, in this paper the relationship between colourfulness and the other attributes of logos will be considered.

## RESULTS

Table 1 shows the mean scale values for each of the 50 logos. There are some interesting observations that can be made from Table 1. For example, the attribute with the highest score (pooled over all logos) is familiar (3.59) whereas the attribute with the lowest score is feminine

(2.05). This *might* suggest that familiarity is an attribute that is important to consumers. The three logos with the highest familiarity score were McDonalds (4.91), Apple (4.64) and Pepsi (4.59) and the logos with the lowest familiarity score were Hitachi (1.82), PetroChina (1.73) and London Symphony Orchestra (1.45). Of course, these results may be dependent upon the cultural backgrounds and life experiences of the participants in this study.

	complex	proportional	unique	familiar	memorable	colourful	feminine	bold	friendly	modern
Uni of leeds	1.68	2.68	2.77	3.64	3.50	1.00	1.50	3.23	2.91	3.23
Twitter	1.32	3.23	3.55	3.86	4.23	2.77	2.23	2.59	4.09	3.73
Target	1.32	3.59	2.68	3.09	4.05	2.73	1.91	3.41	2.23	2.59
Walmart	1.68	2.36	2.45	3.23	3.18	3.36	2.09	2.27	3.36	2.77
Shell	2.32	3.64	3.77	4.32	4.18	4.05	2.32	3.77	2.50	2.68
Apple	1.27	3.14	4.45	4.64	4.73	1.27	2.27	2.68	3.41	4.36
Microsoft	1.73	3.36	3.41	4.50	4.23	4.45	1.91	2.91	3.23	3.00
IBM	2.86	3.36	3.41	4.27	3.59	1.86	1.68	2.95	2.05	2.50
McDonald	1.18	3.86	4.14	4.91	4.86	3.09	2.55	3.36	4.32	3.64
Toyota	2.68	3.45	3.41	3.95	3.45	2.09	1.82	2.64	2.27	1.77
Samsung	1.55	2.95	3.18	4.45	3.73	2.36	2.09	3.00	2.59	3.23
Ford	2.00	3.27	2.82	4.41	3.91	2.05	2.09	2.64	2.68	1.91
Honda	2.32	3.14	2.91	4.05	3.32	2.05	1.59	2.73	2.14	1.82
HP	1.95	3.55	3.14	4.05	3.91	2.09	2.09	3.05	2.91	3.09
Tesco	2.95	2.82	3.09	4.23	3.64	3.45	1.86	2.91	3.23	2.77
PetroChina	2.73	3.45	3.23	1.73	2.50	3.86	2.32	2.82	2.77	2.36
Esxon Mobil	2.23	2.77	2.27	2.05	2.27	1.55	1.41	2.45	1.55	2.50
BP	3.45	3.05	3.55	2.86	3.32	4.00	2.73	2.68	3.36	3.05
VW	3.05	3.59	3.77	4.23	3.91	1.91	2.00	3.36	2.86	2.95
Colgate	1.45	2.64	2.55	4.41	3.86	2.36	2.14	2.95	2.91	2.77
Mazda	2.59	3.55	3.36	4.27	3.64	1.82	2.45	2.77	2.86	2.64
Batman	2.41	3.86	4.09	4.55	4.41	2.91	1.68	3.68	2.27	2.73
Subway	1.45	3.55	3.64	4.50	4.14	3.68	2.50	2.95	3.50	3.09
Motorola	2.36	3.00	3.09	3.68	3.09	2.18	1.64	2.59	2.23	2.41
Roxy	3.68	3.73	3.45	2.32	2.32	1.09	2.18	2.32	1.95	2.50
Lacoste	2.82	2.64	3.77	4.59	4.27	2.59	1.64	3.18	2.09	2.50
Verizon	1.41	2.50	1.82	2.14	2.14	1.45	1.50	2.59	2.14	2.68
National Geographic	1.45	2.23	2.27	1.91	2.09	2.36	2.05	2.73	2.23	2.45
Firefox	3.68	3.05	4.05	4.09	3.86	4.36	2.27	3.32	3.09	2.82
Nissan	2.00	3.32	2.73	4.05	3.27	1.09	1.68	2.36	1.95	2.50
BMW	2.18	3.41	3.86	4.23	4.18	2.68	2.32	2.64	2.64	2.50
Hitachi	1.95	2.41	2.00	1.82	1.91	1.18	1.50	2.36	1.91	2.05
Nestle	3.64	2.82	4.27	4.09	4.14	1.95	3.14	2.50	3.68	2.50
Siemens	1.27	3.14	2.23	3.36	2.95	1.55	1.82	2.64	2.41	2.41
Boeing	2.73	2.45	3.32	2.41	2.32	1.91	1.59	2.82	2.09	2.36
Amazon	1.82	2.95	3.64	4.32	4.32	2.50	2.55	3.05	4.05	3.50
P&G	1.27	2.86	2.36	3.82	3.64	1.77	2.09	3.18	2.55	2.73
Hyundai	2.09	2.91	2.45	3.36	3.18	1.73	1.77	2.50	2.27	2.27
Sony	2.18	2.64	2.73	3.86	3.36	1.09	1.45	2.64	1.95	2.41
3M	1.18	3.55	3.18	3.27	3.73	2.41	1.91	4.05	2.27	2.95
Museum of London	4.05	2.27	4.09	2.23	2.68	4.59	2.86	3.14	4.05	3.95
Pepsi	1.82	3.09	4.09	4.59	4.14	3.82	2.50	3.50	3.41	3.50
Rolex	2.27	3.00	3.55	4.09	3.91	2.23	2.27	3.09	2.36	2.32
Unilever	3.68	3.86	4.27	4.00	3.95	2.68	2.95	3.00	3.91	3.59
Bentley	3.82	3.68	4.14	4.00	3.73	1.09	1.77	3.14	2.36	2.50
Goldman Sachs	1.50	2.45	2.00	2.05	2.41	1.14	1.68	2.86	2.00	2.32
Yamaha	3.73	2.32	3.05	3.00	3.00	2.50	1.73	2.91	2.14	1.73
BBC	1.18	4.14	3.45	4.32	4.50	1.09	1.82	3.91	2.73	3.41
LSD	2.77	2.41	4.00	1.45	2.32	1.86	2.91	2.73	2.59	3.59
Goodwill	3.23	3.05	3.73	2.00	2.95	2.64	1.91	3.18	3.23	3.09

Table 1: The mean scale values for each of the logos for each attribute.

The relationship between colourfulness and the other attributes can be considered by looking at the correlation between colourfulness and each of these attributes and quantifying this with the coefficient of determination.

Colourfulness was not very strongly with any of the attributes. However, there was reasonable correlation with friendly ( $r^2 = 0.28$ ) and feminine ( $r^2 = 0.22$ ) as illustrated in Figure 1. A statistical analysis revealed, however, that there were statistically significant ( $p < 0.05$ ) correlations between

colourfulness and friendly ( $p < 0.001$ ), feminine ( $p < 0.001$ ), bold ( $p = 0.022$ ), modern ( $p = 0.036$ ), unique ( $p = 0.003$ ) and memorable ( $p = 0.036$ ). Table 2 shows the correlations between each of the attributes (those that are statistically significant are underlined).

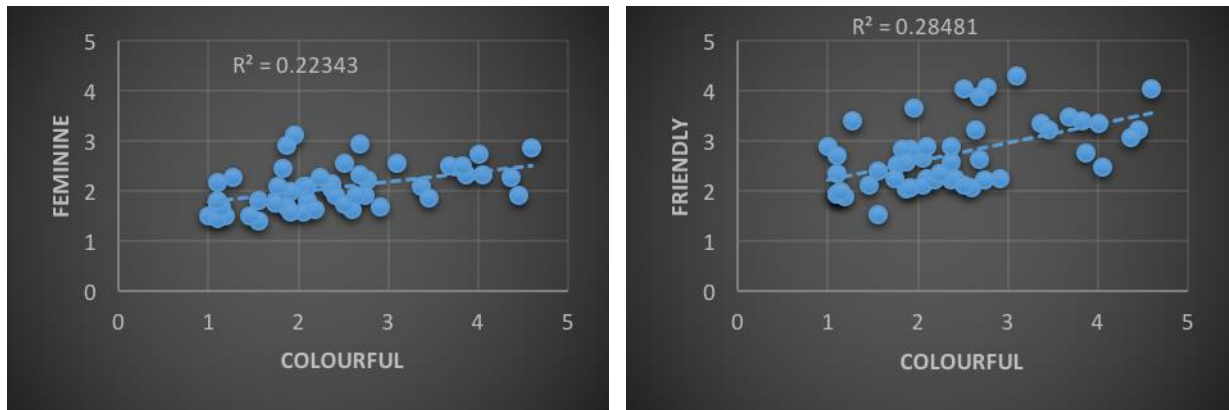

Figure 1: Relationship between colourfulness and feminine (left) and friendly (right) attributes. Each point in the figures represents one of the logos.

		complex	proportional	unique	familiar	memorable	colourful	feminine	bold	friendly	modern
Correlation	complex	1.000	-.034	.465	-.173	-.192	.199	.258	-.102	.040	-.152
	proportional	-.034	1.000	.441	.502	.585	.057	.148	.424	.152	.153
	unique	.465	.441	1.000	.417	.576	.388	.609	.374	.549	.513
	familiar	-.173	.502	.417	1.000	.900	.132	.112	.328	.322	.177
	memorable	-.192	.585	.576	.900	1.000	.257	.294	.502	.502	.393
	colourful	.199	.057	.388	.132	.257	1.000	.473	.286	.534	.257
	feminine	.258	.148	.609	.112	.294	.473	1.000	.068	.731	.523
	bold	-.102	.424	.374	.328	.502	.286	.068	1.000	.155	.321
	friendly	.040	.152	.549	.322	.502	.534	.731	.155	1.000	.720
	modern	-.152	.153	.513	.177	.393	.257	.523	.321	.720	1.000
	Sig. (1-tailed)	complex		.408	.000	.115	.091	.083	.035	.239	.391
proportional		.408		.001	.000	.000	.347	.153	.001	.145	.144
unique		.000	.001		.001	.000	.003	.000	.004	.000	.000
familiar		.115	.000	.001		.000	.180	.220	.010	.011	.109
memorable		.091	.000	.000	.000		.036	.019	.000	.000	.002
colourful		.083	.347	<u>.003</u>	.180	.036		<u>.000</u>	.022	<u>.000</u>	.036
feminine		.035	.153	.000	.220	.019	.000		.320	.000	.000
bold		.239	.001	.004	.010	.000	.022	.320		.142	.012
friendly		.391	.145	.000	.011	.000	.000	.000	.142		.000
modern		.146	.144	.000	.109	.002	.036	.000	.012	.000	

a. Determinant = .001

Table 2: The correlations between each of the attributes. The upper part shows the correlation coefficients ( $r$ ) and the lower part shows the  $p$  values from the statistical test.

Statistically significant correlations exist between other attributes. Most notably, familiar was positively correlated with memorable ( $r = 0.9$ ,  $p < 0.001$ ) and friendly was positively associated modern ( $r = 0.73$ ,  $p < 0.001$ ). The various associations that are evident suggest that factor analysis could be used to reduce the dimensionality of the feature space.

## DISCUSSION

Colourfulness was shown to have statistically significant positive correlations with friendly, feminine bold, modern, unique and memorable. In other words, the more colourful the logo, the more it is perceived as being friendly, feminine bold, modern, unique and memorable. Correlations between other attributes were also found, suggesting that some reduction in dimensionality of the feature space may be possible using factor analysis. The production of a low-dimensional feature space for the evaluation of logos and determining the relationship of this feature space with existing framework for understanding corporate logos (Marsden 2019) will be the next step in this research.

## ACKNOWLEDGEMENTS

This research was funded by The University of Business and Technology, Jeddah College of Advertising, Dhaban, Jeddah, Kingdom of Saudi Arabia.

## REFERENCES

- Bettels, J., and K. P. Wiedmann. 2019. Brand logo symmetry and product design: the spillover effects on consumer inferences. *Journal of Business Research* 97: 1-9.
- Eiseman, L. 2000. *The Pantone guide to communicating with colour*. New York: Grafi x Press Ltd.
- Henderson, P., and J. Cote. 1998. Guidelines for selecting or modifying logos. *Journal of Marketing* 62 (2): 14-30.
- Jamieson, S. 2004. Likert scales: how to (ab)use them. *Medical Education* 38 (12): 1217-1218.
- Kim, M. J., and J. H. Lim. 2019. A comprehensive review on logo literature: research topics, findings, and future directions. *Journal of Marketing Management* 35 (13/14): 1291-1365.
- Marsden, J., 2019. Visualising corporate brands: towards a framework of brandmark expression. *Journal of Brand Strategy* 7 (4): 377-388.
- Norman, G. 2010. Likert scales, levels of measurement and the "laws" of statistics. *Advances In Health Sciences Education* 15 (5): 625-632.
- Phan, R. 2009. Unconstrained colour logo and trademark retrieval using colour edge gradient co-occurrence histograms. ProQuest.
- Riezebos, R. 2003. *Brand management: a theoretical and practical approach*. London: Prentice-Hall.



# Ambiences Seminar



# The semantic color space

**Ferre Alpaerts, Inez Michiels\***

City of 8, Design Semantics Research Association, Antwerp, Belgium

\* inez.michiels@gmail.com

## ABSTRACT

Colors, light, shapes, textures, sounds and even smells are used to emotionally address the user of an architectural space. The processing of sensory stimuli, however, is a complex issue that covers various sciences. A knowledge the architect or designer usually does not have access to. There is a need for a manageable tool to deal with the design of meaning. This paper presents the semantic color space as a model that articulates the relation between meaning, emotion and elements of visual language. The theory behind the model is that sensory input is converted into neurological patterns, and that related patterns synthesize into identifiable mental states. As a tool it provides a designer with components that have a seamless mental match. The story of the model however is not one from input to pattern to mental state, but from a hypothesis about mental state, related patterns, and expression into visual language.

**Keywords:** *genetic semantics, bi-polar, 3-dimensional, meaning, color space*

## INTRODUCTION

Because we are dealing with signs and meaning, we approach the construction of a design system from the perspective of semantics, namely by searching for logical, mathematical systems of giving of meaning. Semantics explores this mathematical logic within human evolutionary biology, cognitive psychology and neurology. Pinker (1994) explains that human understanding shows to be not only a matter of learning and culture but that also an inborn language ability is needed. In this view signs refer to the outside, to the concrete, as well as to an inner, abstract meaning. Recently researchers have provided evidence for Pinker's presumption: "the language ability is contained in our DNA, and is therefore unique human" (De Decker 2006).

Our backing theory takes off from the assumption that meaning derives from innate structures of information processing, from the methods used in the cell. The nervous system and the brain are buildup of cells and it seems logical that the way cells exchange signals relies on the genetic code they possess. From this proposition emerges the idea that the human signaling system can be traced

back to the codons of the DNA. The human ability to use signs is thus based on applications of genetic encoding. We call this key-point ‘genetic semantics’.

## GEOMETRY FROM THE INSIDE OUT

According to Hofstadter (1999) the symbols we use for our communication belong to the assembly language of our brain. Below this assembly level, processing takes place via the ones and zeros of a machine language. We can find this binary code in the DNA, described by Dawkins (2004) as “textual information written in a 4 letter alphabet”.

The DNA codon structure can be presented as a spatial classification system, wherein the four DNA letters are represented by two static (0, 1) and two dynamic (0 to 1, 1 to 0) code signs that are combined in groups of  $2^3$  codon ‘words’. Genetic semantics postulates the hypothesis that the first digit of a codon refers to the depth dimension, the second to the height and the third to the width. In this construction the four ‘letters’ of DNA may be considered as semantic markers introduced by Katz and Fodor (1963). The codon words then refer to the key-concepts of the inner meaning system. Through their code they get a place in the space and can orient themselves (see Figure 1).

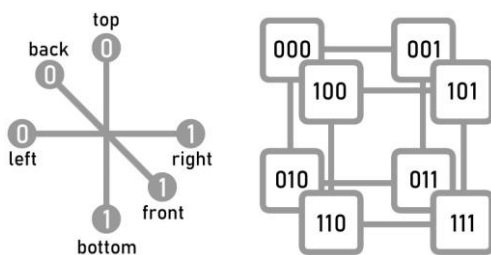

Figure 1:  
Three axes of meaning in the genetic semantic space.

Moreover, the cube-shaped semantic space allows a hierarchy of meaning, starting from the abstract zeros and ones, via the dimensional semantic markers, into an endlessly refining structure of conceptual levels of 8, 64, 4096, ... On the dimensional level each axis represents a distinguishing aspect of meaning, given by the elementary properties of the space, which stand as opposing pairs on the dimensions. In the depth the meaning is given by the contrast back (0) / front (1). In the height it is above (0) / below (1), in the width: left (0) / right (1).

The depth dimension is about differences or similarities. Which is equivalent to us there we tend to seek contact with, thus coming closer and facing us in the front. What is strange makes us back away, turn our back. It is the theoretical dimension, about communication, the what question, the profound, the in depth. The height is the dimension of the force of gravity. At the top is the power that dominates. At the bottom is the compliant. It is the hard on top opposite to the gentle below, the strong towering above the weak. This is the practical dimension, the how questions, the technical approach, the know-how. The width is the dimension which is determined by the hands, to the left and to the right of the body. This is about activity. An estimated 85 to 90% of humanity has an active right hand. We usually express the past with the left hand, and that which lies in the future with the right hand. The past is associated with passivity and the present or the future with activity. It is the history dimension, the why questions.

The bi-polar 3D structure is crucial in the genetic semantics system and according to the semanticist Greimas (1966) it is inherent to human thinking. He showed that not only do we think binary, in antagonists, but also dimensionally, according to aspects. Depth, height and width are

dimensions of imaginary but nevertheless meaningful positions and movements that form the basis of the meaning. Dawkins (2004) shows with a research with newborn chicks that above and below has a meaning that cannot be learned. He explains that in the very early embryo, each cell is told which place in the 3-dimensional body it is in through the mediation of special control genes. Also, for the most primitive beings such as the rag worm or even the amoeba, being our ancestors estimated at 600 million years ago and older, front and rear, left and right, and up and down have a clear meaning.

Establishing associations appears to be a primary principle of the neocortex (Edelman and Mountcastle 1982). Being able of building networks of associated meanings seems essential for our model. That's exactly what will happen on the next levels, starting with the 8-level, as a first step to more complexity in the meaning hierarchy. By combining three dimensional parameters into a codon each time, we obtain 8 codons of meaning that we can place on the 8 vertices of the cube. Not only they are themselves connected to each other by their code, each of them in turn form clusters of associated meaning, put together through synonyms and antonyms.

Their place in the semantic space is not arbitrary but determined by their composite dimensions. For example, the code 000 is fixed at the back, top and left. The meaning of this position can be dimensionally summarized as: difference, far, hard, heavy, passive, few. We can associate primary keywords with it such as: distance, depth, carrier, material, real, earth, inwards, contract, cold, slow. The opposite position with the code 111 and the dimensional opposite meanings: equal, close, soft, lightweight, active and many, is associated with keywords such as: near, superficial, immaterial, unreal, heaven, outwards, expand, warm, fast. This way, a number of keywords, associations of meaning, that we call primary are clustered together around 8 codons.

64-level keywords are formed by combining 8-level keywords ( $8 \times 8 = 64$ ), thus making them even more complex in meaning. Here you can find assembled words such as "crossroads" (cross (010); road (100)), or "nature reserve" (nature (010), to preserve (000)) where the 8-level source is still clear. But also words such as "cooking", "family", "detective" are 64-level.

## COLOR AND MEANING

Now that we have established a classification system in which concepts and ideas have been given a logical position in a layered model, the way is open to add colors. Colors are important for semantics because of their abstract quality. It is better to replace the zeros and ones with a color code, which offers more possibilities for direct applications. We start from the dimensional level and try to connect the psychological and physical parameters of color to the three dimensions of meaning. The psychological parameters which prove important when it comes to emotional values, are temperature, weight and activation (Ou et al. 2004). The physical parameters include wavelength, lightness and saturation.

A clear correlation has been established between a feeling of temperature and the wavelength of a color. Psychological research shows that the subjective experience of color temperature changes abruptly when the value above 120° CIELAB has been exceeded. The same sudden change occurs around 330° CIELAB (da Pos and Valenti 2007). This connection appears to work more or less cross-culturally (Sato et al. 2003). There is a strong connection with the color temperature parameter cold/warm and the parameter far away/close by. Warm colors tend to come forward, while cool

colors tend to step back. That is why wavelength and temperature are placed on the depth axis of the semantic space. In the height dimension fits the lightness and the weight parameter. Research results support the earlier qualitative findings that dark colors appear heavier than light colors, while providing quantitative meaning to the terms dark and light (Alexander and Shansky 1976). Dark colors, when applied above the viewer, tend to press down or dominate. Because of their heaviness, the weight is physically sensed. The saturation and activation parameters connect with the activating width dimension. The amount of chroma has an effect on activity (Miyamoto 2003). The brighter the color, the more a sense of dynamism will arise (Valdez and Mehrabian 1994). Passive feelings such as sadness and fear are associated with very desaturated monochrome colors, while active feelings such as happiness, surprise and anger are linked to bright and very contrasting colors (da Pos and Green-Armytage 2007).

Now having the parameters of color connected to those of meaning, we can proceed on the 8-level with defining and placing 8 primary colors on the corners of the semantic space. This is done by codoning their 3 psychological parameters. For instance the color red is defined by the parameters warm, heavy and active and thus finds its place in the front, top and right of the space. The other colors are blue, black, green, purple, brown, white and yellow (see Figure 2). The back colors are the cold ones, the front colors are warm. At the top are the heavy colors that weigh on the lightweight colors below. Passive colors are on the left side, while the active ones are on the right.

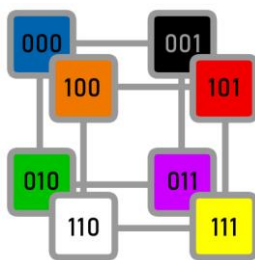

Figure 2:  
The semantic color space.

That these 8 colors are primary is confirmed by different sources. From linguistics we know, thanks to the research by Berlin and Kay (Kay 1975), that primary colors are first mentioned in the evolution of color naming. The researchers confirm that cross-culturally between 7 to 12 primary colors are named initially. Following the evolution we get a color range of dark (black) and bright (white), red, yellow/green, blue, brown, purple/pink/orange/gray. Moreover, there is substantial agreement over namings of primary colors across different cultures (Dawkins 2004). From biology, there is the function of retinal ganglion cells that confirm the selection of the eight primary colors. Six primary colors interact as antagonists, where blue is opposite to yellow, green to red and dark to light. Purple and brown are generated by the simultaneous stimulation of these cells.

Through metaphors, color psychology, striking applications of colors in imaging we can connect them with words. There is a lot of confusion about the meaning of colors. Their codic meaning is universal because it is determined by their physical characteristics. The abstract meaning, although sometimes very clear, cannot be automatically translated into words. There are no fixed rules, because language is an open system. The 'translation' is rather something like laying a tangram, the Chinese puzzle that suggests a figure. Phrases like "red means love" assume a strict, unambiguous relationship. 'Red' does not get meaning through 'love'. In reverse, the words get meaning through the colors, they are 'emotionally colored' as in 'love is red'. The abstract meaning of the colors is

universal, their external meaning is culturally given, which does not imply that it would be entirely conventional.

According to the comparative research of Alpaerts and Michiels (2018) “earth” was placed under the code 000, i.e. the codic combination for the color blue. On a dimensional level, the idea can be described as the sum of massive (back) + hard (top) + passive (left). There is a frequently recurring relationship with the term “earth” and the color blue. The earth is referred to as the “blue planet”. In many simple images such as logos the globe is presented in blue. In Christian representations, the heavenly god is depicted in yellow opposite the blue earth over which he rules. Blue is the color of the reunification with (mother) earth and has a calming effect (Heller 1989). Buddhist meditation techniques see the earth as lapis lazuli. In Ancient Egypt as well as in India (Shiva, Vishnu, Krishna), blue is the divine color of an earth god.

When combining two primary colors we are giving meaning on the 64-level. In two-color combinations it is about the relationship between the bottom or background color and the top or front color. An additivity relationship was found between single-color and color-combination emotions. This relationship predicts color emotions for a color pair by averaging the color emotions of individual colors that generate the pair (Ou et al. 2004).

When a color is identified as an 8-level sign, for example ‘red’ (101), then it concerns a more general meaning such as ‘love’ in a broad sense. On 64-level one distinguishes more specific meanings which can be presented as a color combination or as a specific color tint. Erotic love and romantic love are often pictured respectively in the color combinations purple-on-red and red-on-black, while charity and soft erotic can be expressed in salmon red and pink red.

Color tints can be classified in two ways. The first way is to combine the 3 psychological color parameters with the 3 physical ones, thus becoming a 64-level sign. The psychological parameters define the primary color, while the physical parameters fine-tune the primary colors into shades and tints. A second way to classify color tints is to perform a calculation or operation on the digital code, thus resulting in 8 tints of blue, 8 tints of black, etc. By combining these 64-level color tints the meaning is refined even more and becomes 4096-level. Because of the complexity of this calculation and the consequences for the meaning of the 64 tints it cannot be explained in the current paper.

Genetic semantics defends the existence of abstract ideas. As shown with the Bouba-Kiki effect (Köhler 1947), there is no difference at a certain level between sensory experiences. We feel this when we compare sign systems, for example we can call a color, a sound as well as a taste ‘sharp’. Synesthesia mainly takes place on the dimensional level by comparing the parameters. The semantic color space is equipped to connect other senses such as shape, composition, texture, music, body language or even taste to meaning.

## CONCLUSION

We have shown how the semantic color space is built as a layered classification system, of which the cells are provided with coordinate formulae that are formed by codon words. Thus arises a huge network of concepts and ideas, representing signs such as keywords, primary colors, color combinations and tints, but also shapes, compositions, materials, textures, sounds, body language, tastes. This is the result of more than 20 years of research. By carefully comparing statistical research of correlations between the different sensory parameters, a solid network of design handles is formed with which designers can create meaning in a more controlled and scientific way, getting a

solid grip on the emotional language they express. Since 2018, the authors have started to fill in an online version of the semantic color space that can be consulted (Alpaerts and Michiels 2018).

The current model promises a design system for the future as endless refinement of meaning is incorporated. This groundbreaking semantic color space thus responds to the new evolutions in design practice, as design becomes more and more a sense-making creative activity. The semantic color space is a step forward to the analytical or logical turn of design, away from the arts-and-crafts orientation, without losing touch with intuition and gut feeling.

## REFERENCES

- Alexander, K. R., and M. S. Shansky. 1976. Influence of hue, value, and chroma on the perceived heaviness of colors. *Perception & Psychophysics* 19 (1): 72-74.
- Alpaerts, F., and I. Michiels. 2018. Khnum, design semantic database. Online: <https://kxnum.club>.
- da Pos, O., and P. Green-Armytage. 2007. Facial expression. Colour and basic emotions. *Colour: Design and Creativity* 1: 1-15.
- da Pos, O., and V. Valenti. 2007. Warm and cold colours. In: *AIC 2007, "Color Science for Industry", Proceedings of the Midterm Meeting of the International Color Association*, Hangzhou, China, 12-14 July 2007, G. Ye and H. Xu, eds. Hangzhou: Color Association of China, 41-44.
- Dawkins, R. 2004. *The ancestor's tale: a pilgrimage to the dawn of life*. London: Weidenfeld & Nicolson.
- De Decker, K. 2006. Het lichaam spreekt. *Knack Magazine*, 12 april.
- Edelman, G. M., and V. B. Mountcastle. 1982. *The mindful brain. Cortical organization and the group-selective theory of higher brain function*. Cambridge, MA: The MIT Press.
- Greimas, A. J. 1966. *Semantique structurale, recherche de methode*. Paris: Larousse.
- Heller, E. 1989. *Wie Farben wirken*. Hamburg: Rowohlt Verlag.
- Hofstadter, D. R. 1999. *Gödel, Escher, Bach: an eternal golden braid*. New York: Basic Books.
- Katz, J. J., and J. A. Fodor. 1963. The structure of a semantic theory. *Language* 39 (2): 170-210.
- Kay, P. 1975. Synchronic variability and diachronic change in basic color terms. *Language in Society* 4 (3): 257-270.
- Köhler, W. 1947. *Gestalt psychology*, 2nd ed. New York: Liveright.
- Miyamoto, M. 2003. Effects of light sources and colors of interior elements on atmosphere in the living room. In: *AIC 2003 Bangkok, Proceedings of the Midterm Meeting "Color Communication and Management"*, Bangkok, 4-6 August 2003, A. Hansuebsai, ed. Bangkok: The Color Group of Thailand, 347-351.
- Ou, L. C., M. R. Luo, A. Woodcock, and A. Wright. 2004. A study of colour emotion and colour preference. Part II: Colour emotions for two-colour combinations. *Color Research and Application* 29 (4): 292-298.
- Pinker, S. 1994. *The language instinct*. New York: Penguin Books.
- Sato, T., J. Xin, and A. Hansuebsai. 2003. Numerical expressions of colour emotion and its application. In: *AIC 2003 Bangkok, Proceedings of the Midterm Meeting "Color Communication and Management"*, Bangkok, 4-6 August 2003, A. Hansuebsai, ed. Bangkok: The Color Group of Thailand, 365-369.
- Valdez, P., and A. Mehrabian. 1994. Effects of color on emotions. *Journal of Experimental Psychology: General* 123: 394-409.

# Perception, color and user experience: a study in a hospital environment of hemodialysis

Imara A. M. Duarte\*, Carla P. A. Pereira

Federal University of Campina Grande, Paraíba, Brazil

\* imara.duarte@gmail.com

## ABSTRACT

This research aimed to identify the levels of affection of users, referring to the hospital environment color of hemodialysis, and to compare these data with color schemes indicated in the literature. Were interviewed 115 individuals, including patients, caregivers and medical staff from two hospitals. The PANAS-VPR scale was used to identify the affects on real environments and their digitally altered photographs. In these simulations, four hot and cold color combinations were tested using the Munsell notations. The investigated real environments, mostly white, obtained lower medians of positive affect. The color schemes used in the simulations (photographs) showed high positive affect medians for the prevalent cold arrangements, followed by the prevalent warm arrangements. The overall preference of users was higher for the arrangement with the predominance of light blue, followed by light green, beige, light pink and, finally, the real environment white.

**Keywords:** *UX design, color, perception, hospital, hemodialysis*

## INTRODUCTION

Color is one of the perceptible aspects inherent in the environment, becoming a means of information and communication necessary for the interpretation and understanding of natural and artificial architecture. In this context, their perception involves associative, synesthetic, symbolic, emotional and psychological aspects that influence individuals, as already approached by researchers such as Mahnke (1996), Elliot & Maier (2014), Ghamari & Amor (2016), and Moutinho (2016).

Mahnke (1996) and Elliot & Maier (2014) state that these subjective aspects are the result of an individual understanding, from which the study of color phenomena should include interpretations and approaches that seek to understand emotions and their physical reactions. Emotional experiences occur when stimulus representations (physical and social), affect representations, and personal representations coincide in memory, influencing individual behavior (Evans 2000, Ledoux 1989). In this sense, in relation to the affective perception of environmental color, research indicates that color can have important meanings and influence affects, cognitions and attitudes in different



contexts; assuming that human performance can be influenced by their color experiences (Linhares et al. 2008, Elliot & Maier 2014).

The relationships between the built environment and health have been investigated using psychological and physiological indicators of well-being. Studies focused on the hospital environment indicate that color and light can affect patient recovery rates and improve the quality of the overall user experience (Dalke et al. 2006); besides influencing the association between environmental perception and quality of services provided by the medical team (Dijkstra 2009). Apparently, the proper use of colors, among other aspects in the environment, helps in spatial orientation, location and communication between teams; and can contribute to job satisfaction and well-being (Rangel & Mont’alvão 2011). On the other hand, the number of studies on the influence of achromatic colors ostensibly applied in the hospital environment is limited (Elliot & Maier 2014).

For Dijkstra et al. (2008), in health care settings, to provide a welcoming experience to people with poor health, emotionally vulnerable, and with a high degree of fear and stress, the proper use of colors is necessary, among others aspects such as lighting, sounds and aromas in the environment, taking into account the context of use and the psychophysiological conditions of the users. However, the literature review of this research did not identify studies related to the specific environmental perception of color in the hospital dialysis sector.

This article is based on a master’s research conducted at the Graduate Program in Design of the Federal University of Campina Grande (UFCG), Brazil, which aimed to identify color-related affects in a hospital environment of hemodialysis.

## EXPERIMENTS

An exploratory study based on semi-structured interviews was conducted, addressing the color of the real hospital environment, in context of use, and simulations of this same environment in projected colors (Figure 1). This study recorded the levels of affect reported by users regarding the color of the environments, and compared them with the affective perceptions regarding the colors of the simulations, designed according to recommendations for the use of color in health environments, in the light of the scientific literature.

The sample, consisting of random adherence and convenience, totaled 115 adult individuals — including medical staff, patients and caregivers— all users of hemodialysis environments in two hospitals in Campina Grande, Brazil. Interviews were conducted in the hospitals themselves, supported by forms, and presentation of printed images of hemodialysis environments, digitally treated, in four color versions for each environment: two schemes with predominance of cold tones and two schemes with predominance of warm tones. These combinations were made in four colors: light blue (Munsell notation 1.75PB / 9.09 / 2.1), beige (4.08Y / 9.08 / 3.0), light green (8.46GY / 8.74 / 27) and light pink (2.69RP / 9.03 / 3.1).

For measurement, we used the PANAS-VPR (Positive and Negative Affect Schedule, reduced) tool, which has ten adjectives describing affective states —enthusiastic, active, nervous, tormented, scared, frightened, guilty, interested, determined, inspired— taking as an example of command: “In relation to the hemodialysis environment colors I feel *interested*”. The response options were presented in a five-point Likert scale, graded as follows: ‘strongly agree’, ‘agree’, ‘don’t know’, ‘disagree’ and ‘totally disagree’ to identify the valence and activation of affections as a function of the actual environmental color and simulations according to the scale. Statistical treatment was performed using medians, followed by descriptive analysis, with data presented in Kiviat radar chart.



Figure 1: Image of one of the dialysis environments studied (left) and projected color simulations.

## RESULTS AND DISCUSSION

The profile of respondents was individuals aged 18 to 40 years (44%), with complete secondary level (56%), women (73%), users of visual correction (59%), who used the environment under study for less than two years (42%) for at least twelve hours per week (64%). They are therefore intermittent users, experienced in the environment (professionals or patients) by time and frequency of use, fitting the long term permanence characteristics as defined by Dalke & Matheson (2007).

### Real environment

In both hospitals, the walls and ceilings are white, with reflective or satin finish (Figure 1). These characteristics, associated with the high reflectance index of white color, considering its predominant presence in the environments, can cause reflections, disorientation, visual fatigue, decreased visual acuity and sensory monotony, according to the works of Dalke et al. (2006), Mahnke (1996), Rangel & Mont’alvão (2011), among others. Despite these possible negative consequences, users considered the environment color ‘normal’ or expected for the location.

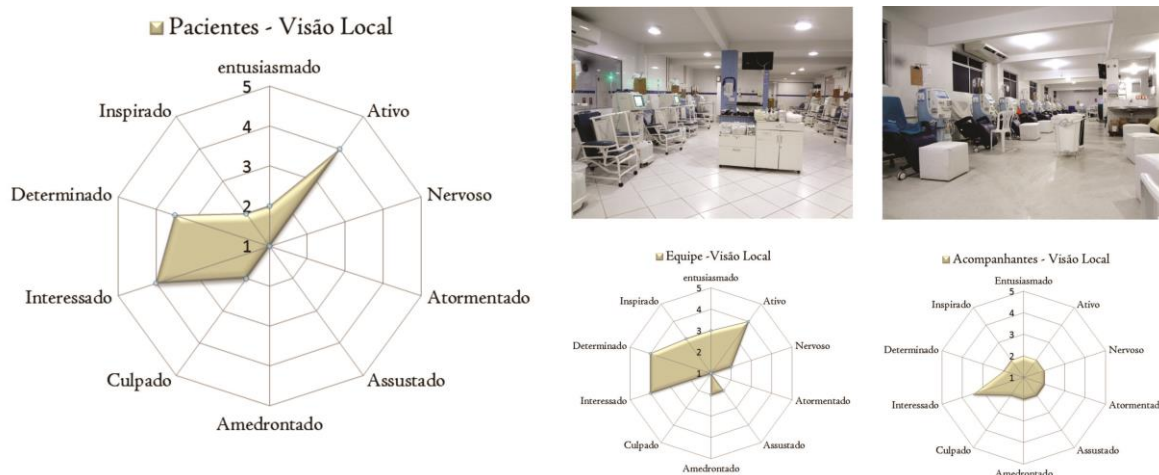

Figure 2: Graphs of users’ affective perceptions about hemodialysis site (real environment).

For real environments, the affective perception of patients and teams reached level 4 in the items ‘active’, ‘determined’ and ‘interested’, suggesting a high level of attention and readiness (Figure 2). For teams, attention and readiness are related to median 3 of item ‘inspired’, with medians 2 of items ‘scared’ and ‘frightened’; suggesting tension and positive affection, despite some fear. For patients, the median 2 in the items “inspired” and “guilty”, added to the high readiness and

attention, indicate negative affect, suggesting a tendency for reflection and tension. The companions maintained a relative affective balance, showing few negative and positive affects, except for the item “interested” with median 3.5, which indicates attention and some degree of positive affect.

### Simulation of projected color environments

For the simulations of environments with ‘predominantly cold 1’ color arrangement, positive affects were prevalent with medians 4 for the three groups of respondents, highlighting the group of patients due to the absence of negative affect median, indicating a preference for this scheme color (Figure 3). The teams presented median 5 in the item ‘interested’, also suggesting preference and high positive affect. The companions, on the other hand, showed negative affection in items such as ‘nervous’, ‘scared’, ‘frightened’ and ‘guilty’, although with low average, indicating some discomfort.

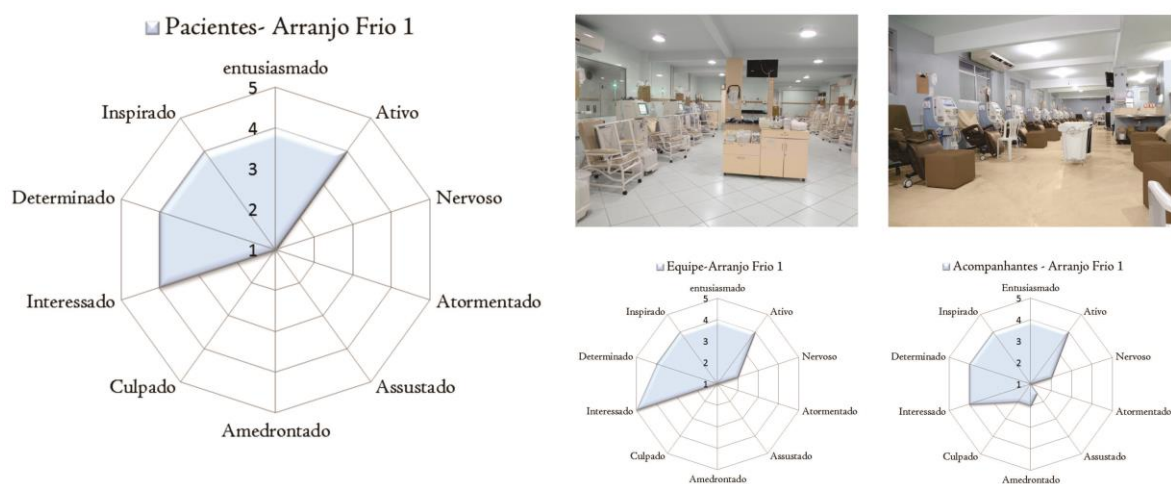

Figure 3: Graphs of users’ affective perceptions for ‘predominantly cold 1’ color arrangement.

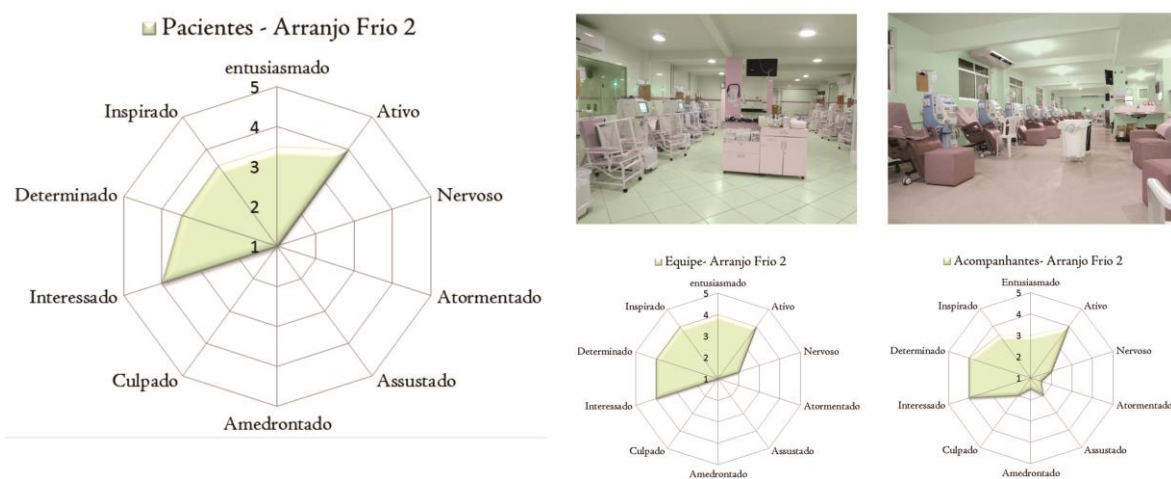

Figure 4: Graphs of users’ affective perceptions for ‘predominantly cold 2’ color arrangement.

For the ‘predominantly cold 2’ chromatic arrangement, positive affects were prevalent with medians 3 and 4 for the three respondent groups (Figure 4). Once again, the group of patients stands out due to the absence of a median of negative affect, indicating a preference for this color scheme, although with less interest compared to the “predominant cold 1” arrangement. The teams

presented median 4 in the positive affect items, indicating a preference for these colors. The companions had a lower median than the others of positive affect (item ‘enthusiastic’) and irregularities in all negative affect items suggesting discomfort, however, the overview is positive affect.

For environments with predominant hot 1 arrangement, a median 4 was identified for the items determined and active; and median lows in the items ‘enthusiastic’ (2) and ‘interested’ (2) for patients. They even had a median 2 on the items ‘frightened’ and ‘scared’, suggesting strong unrest and negative affect (Figure 5). The teams and companions differ in the item ‘interested’. This last group showed median 3 in the referred item which, together with medians between 1.5 and 2 of other negative affect items, indicate a certain intensity of negative perception; although there is a prevalence of positive affect in companions and teams for this color scheme.

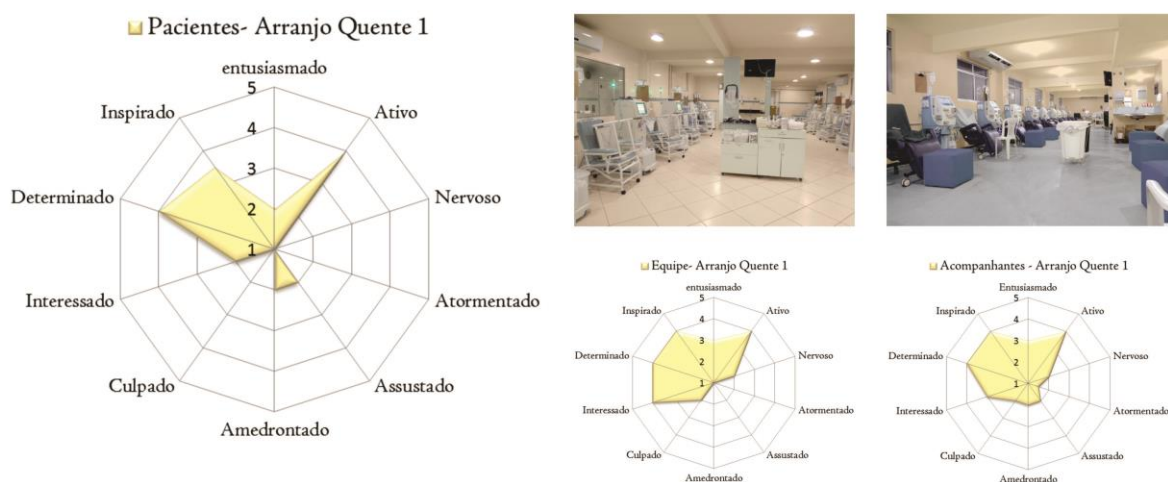

Figure 5: Graphs of users’ affective perceptions for ‘predominantly hot 1’ color arrangement.

Finally, the ‘predominantly warm 2’ color arrangement had a prevalence of medians 4 in positive affect among patients and teams, showing lower medians (1.5 and 2) of negative affect, showing a predominance of positive affect (Figure 6). The companions had lower median in the items inspired (2,5), enthusiastic (3) and determined (3,5), which indicates little interest in the chromatic arrangement, although the environment is positively perceived.

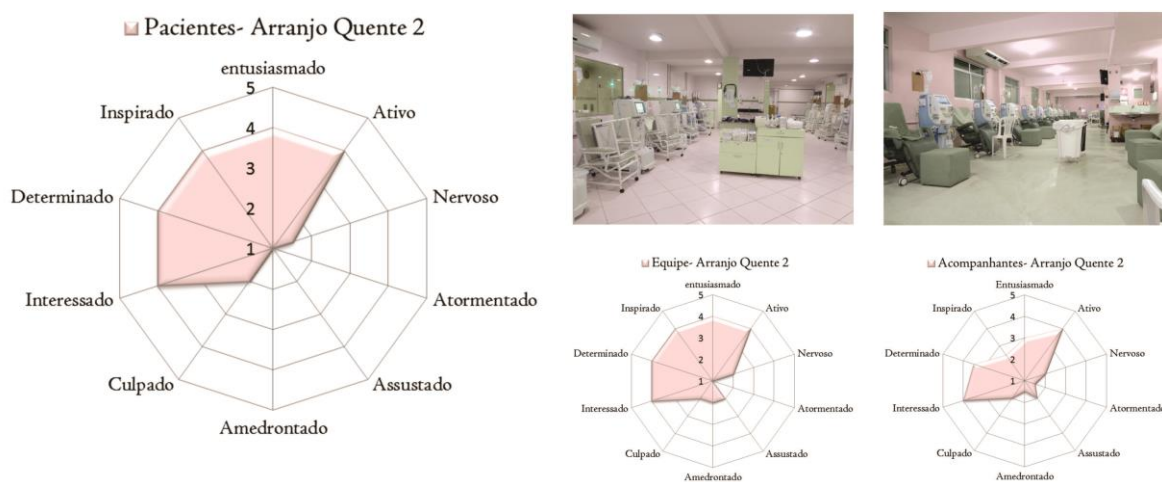

Figure 6: Graphs of users’ affective perceptions for ‘predominantly hot 2’ color arrangement.

## CONCLUSION

The real environments investigated, mostly white, presented lower medians of positive affect in relation to the color schemes used in the simulations (photographs), which presented high medians of positive affect with the prevalent cold arrangements, followed by the prevalent warm arrangements, respectively. Despite the tension inherent in activities performed in the hospital environment of hemodialysis, digitally simulated colors were well received by respondents.

The general preference of users was higher for the color arrangement with predominance of light blue, followed by light green, beige, light pink and, finally, the mostly white original environment. The data points to the preference for a softly colored location, including the ceiling, and with some contrast, as opposed to a white place that has only brightness variations. These results corroborate the literature indications for visual stimulation through the application of complementary colors, tonal variations and the use of light colors.

## ACKNOWLEDGEMENTS

The authors are grateful to CAPES for their support of the research grant; as well as all patients, caregivers and teams who were willing to contribute to this work. This study obtained a favorable opinion from the Research Ethics Committee of the Federal University of Campina Grande and has no conflicts of interest.

## REFERENCES

- Dalke, H., J. Little, E. Niemann, N. Camgoz, G. Steadman, S. Hill, and L. Stott. 2006. Colour and lighting in hospital design. *Optics & Laser Technology* 38: 343-365.
- Dalke, H., and M. Matheson. 2007. *colour design schemes for long-term healthcare environments*. London: Kingston University.
- Dijkstra, K. 2009. *Understanding healing environments: effects of physical environmental stimuli on patients' health and well-being*. The Netherlands: University of Twente, thesis.
- Dijkstra, K., M. E. Pieterse, and A. T. H. Pruyn. 2008. Individual differences in reactions towards color in simulated healthcare environments: The role of stimulus screening ability. *Journal of Environmental Psychology* 28: 268-277.
- Elliot, A. J., and M. A. Maier. 2014. Color psychology: effects of perceiving color on psychological functioning in humans. *Annual Review of Psychology* 65: 95-120.
- Evans, H. M. 2000. The emotional brain: the mysterious underpinnings of emotional life. *Neuropsychoanalysis: Interdisciplinary Journal for Psychoanalysis and the Neurosciences*. 2: 91-95.
- Ghamari, H., and C. Amor. 2016. The role of color in healthcare environments, emergent bodies of evidence-based design approach. *Sociology and Anthropology*. 4: 1020-1029.
- Ledoux, J. E. 1989. Cognitive-emotional interactions in the brain. *Cognition and Emotion* 3: 267-289.
- Linhares, J. M., P. D. Pinto, and S. M. C. Nascimento. 2008. The number of discernable colors in natural scenes. *Journal of the Optical Society of America A* 25: 2918-2924.
- Mahnke, F. H. 1996. *Color, environment and human response*. New York: John Wiley & Sons.
- Moutinho, N. A. 2016. *A cor no processo criativo: O espaço da cor no desenho de arquitetura*. Lisbon: Universidade de Lisboa, thesis.
- Rangel, M., and C. Mont'alvão. 2011. Color and wayfinding: a research in a hospital environment. In: *Human Factors and Ergonomics Society 55th Annual Meeting, Proceedings*, Las Vegas, 575-578.

# Correlation analysis of color and function of urban architecture: taking Shanghai as an example

Aiping Gou<sup>a</sup>, Jiangbo Wang<sup>b\*</sup>

<sup>a</sup> Ecology Institute, Shanghai Institute of Technology, Shanghai 201418, China

<sup>b</sup> Department of Architecture, Nanjing Tech University, Nanjing, Jiangsu 211816, China

\* wjb623@163.com

## ABSTRACT

To understand the relationship of color and architectural function, the research makes an overall investigation of Shanghai main urban area with 680 square kilometers. Buildings are divided into seven categories by function, including residence, business, office, culture, education, and so on.

First, the color information of buildings of different functions is classified. Second, the color attribute information for each sample is split, including 20,433 data. Again, the scatter plot is drawn, and the number and proportion of color samples in different intervals are counted, and the distribution intervals of color tendency, brightness, and chroma are identified. By SPSS statistical analysis, the research analyzes the correlation between the building functions and color attributes of the main urban area of Shanghai. The study shows that there is a correlation between the architectural function and the color attribute, but the significance is weak.

At the same time, the research group undertake the rehabilitating project of the old city of Jin'an district, the very central part in inner Shanghai. Practice shows that color in space continuity is far more important than function itself.

**Keywords:** *architecture, function, color, relevance, space*

## INTRODUCTION

In the past 20 years, many cities in China have successively compiled urban color schemes. The purpose is to establish a reasonable color orientation for the city, to clarify the urban color features, and to provide different functional building regulations. In 2018, Shanghai issued the "Three-Year Action Plan for the Construction of 'Beautiful Homes' in Shanghai Residential Quarters (2018-2020)", its main form of expression is "Three-beauty Movement", that is, the construction of beautiful neighborhoods, beautiful homes and beautiful villages. Since 2018, under the mission of a series project of "Shanghai Urban Color Research", the research group make an overall measure and evaluation on the present color, and notice that color is not always combined with architectural function, neither always in the real construction project.

## RESEARCH METHODS AND DATA

The research scope of the research group is within the outer ring road of Shanghai. The total land area is about 664 square kilometers with 11 million permanent residents. With numerous historical buildings and diverse styles, it is a typical representative of modern Chinese cities.

Data collected on site: The research team divides buildings into 13 categories according to their functions: residential, office, business, education, industry, culture, medical, scientific research, transportation, sports, religion, military, and others. Since the latter six types of building functions account for a small proportion of the city's buildings, the research aims to study the top seven types of building functions, namely, color, relevance studies in housing, office, business, education, industry, culture, and medical care.

Select the data of the above four types of building functions, color brightness, chroma, and hue, and use SPSS software to statistically analyze the building function and color attribute data. Pearson correlation analysis was carried out between the four variables of building function, brightness, chroma and hue in the study area (Fan et al. 2014).

Number	Building function	Abbr.	Y	R	G	B	N	Total
1	Residential	RE	2284	1191	79	283	344	4181
2	Office	OF	383	275	49	292	72	1071
3	Commerce	CM	234	134	25	140	63	596
4	Education	ED	136	167	9	28	23	363
5	Industry	IN	101	67	4	46	88	306
6	Culture	CU	45	37	4	7	17	110
7	Medical	MT	43	29	2	4	11	89
8	Research	RH	14	13	1	2	8	38
9	Traffic	TR	9	4	2	2	6	23
10	Physical	PH	6	5	1	3	5	20
11	Religion	RN	11	6		1	1	19
12	Military	MI	1	1			1	3
13	Other	QT	2					2
<b>Total</b>			<b>3269</b>	<b>1929</b>	<b>176</b>	<b>808</b>	<b>639</b>	<b>6821</b>

Table 1: Relationship between building function category and color coefficient.

## ANALYSIS RESULTS

### Interval of color three attributes

**Hue:** Hue is the most important feature of color and is the most important indicator for distinguishing different colors. According to the statistical results, among the 41 hue, the most common hue of each building function are Y, Y10R, Y20R, Y30R, Y50R, Y80R, R, R50B, R80B, B, B70G, B80G, G, G10Y, N. The most important among the functional buildings are the yellow and red systems. Yellow is the largest proportion of residential, office, commercial, and cultural buildings in color. Among them, the most common hue in residential buildings are Y20R, R80B, Y80R, G; the most common hue in office buildings are Y50R, Y80R, R50B, R80B, R, G; the most common hue in commercial buildings Y30R, R50B, R80B, G; the most common hue in cultural buildings are Y50R, Y80R, R80B, B, B70G.

**Brightness:** The proportion of high-lightness buildings in the range of 0-10 in the lightness interval is the highest. Low, medium, medium, and medium-high brightness frequencies in the range of 60-90, 40-55, 25-35, and 15-20 in the lightness interval are less frequently used.

**Chroma:** According to the results, the low chroma of the functional buildings in the study area is the highest in the 0-10 interval, which is basically above 40%, indicating that the architectural color in the study area generally exhibits low chroma characteristics.

### Correlation analysis between building function and color attribute

#### Building function and brightness

All kinds of building functions mainly show high-lightness tendency in lightness, and low-medium and low-lightness are less used. The Pearson correlation coefficient of the two variables “architectural function” and “lightness” is  $r = -0.069$ , and the corresponding significant probability of the two is  $\text{Sig} = 0.000\%$  (that is, the assumption of  $r = 0$  in the foregoing is negative, there is a negative linear correlation between them); while  $|r| = 0.069 < 0.3$ , the linear correlation between the two variables is weak. Finally, it can be concluded that the building function has a correlation with the brightness, and its significance (correlation) is weak, indicating that the various building functions in the study area use the most low-light color, not only concentrated in the low-lightness range (Figure 1).

#### Building function and saturation

The Pearson correlation coefficient of the two variables “architectural function” and “chroma” is  $r = 0.120$ , and the corresponding significant probability of the two is  $\text{Sig} = 0.000\%$  (that is, the hypothesis of  $r = 0$  in the foregoing, There is a positive linear correlation); while  $|r| = 0.20 < 0.3$ , the linear correlation between the two variables is weak. It shows that the functional buildings are dense in the low chroma 0-10 interval, and are sparsely distributed in the medium chroma, medium high chroma and high chroma intervals (Figure 2).

#### Building function and hue

The Pearson correlation coefficient of the two variables “architectural function” and “hue” is  $r = 0.122$ , and the corresponding significant probability of the two is  $\text{Sig} = 0.000\%$  (that is, the assumption of  $r = 0$  in the foregoing, There is a positive linear correlation); while  $|r| = 0.122 < 0.3$ , the linear correlation between the two variables is weak. It shows that there is a correlation between the function and the hue of each building, but the significance is weak (Figure 3).

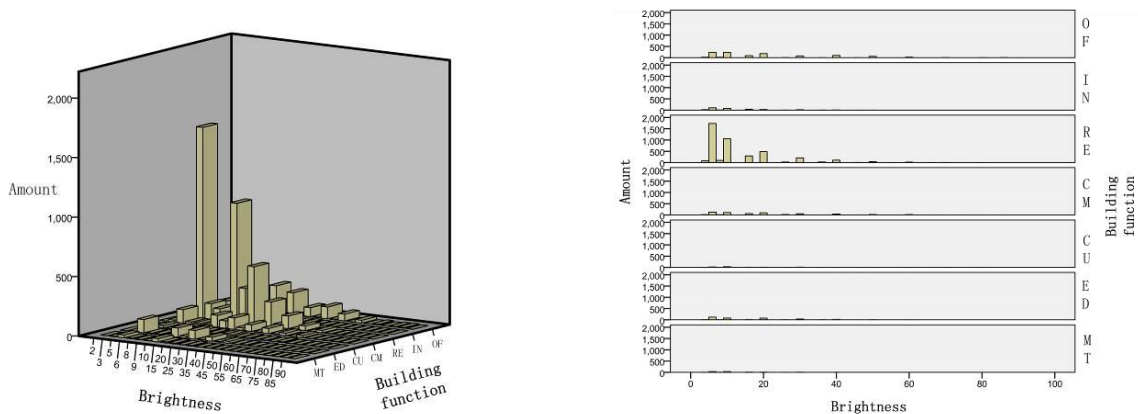

Figure 1: Building function distribution in the lightness interval.



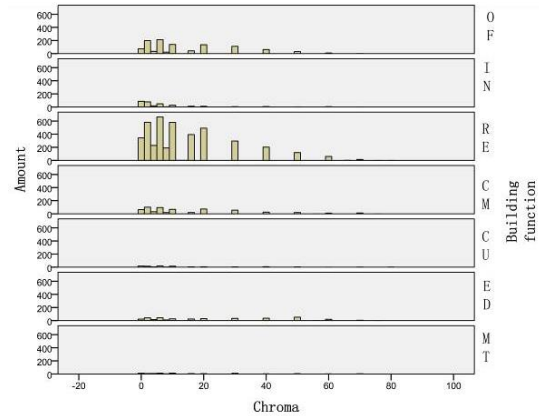
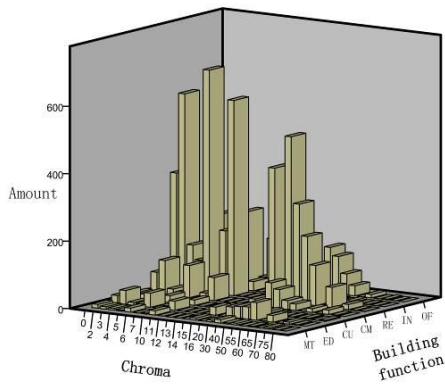

Figure 2: Building function distribution in the chroma interval.

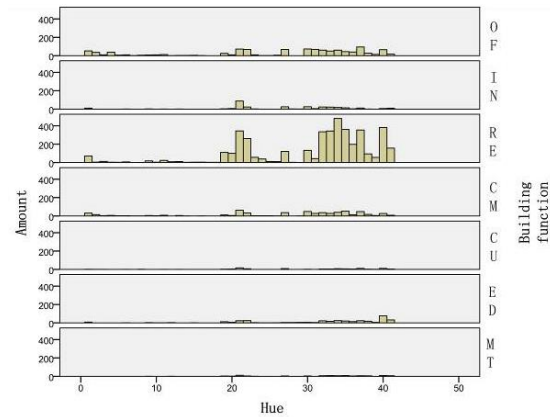
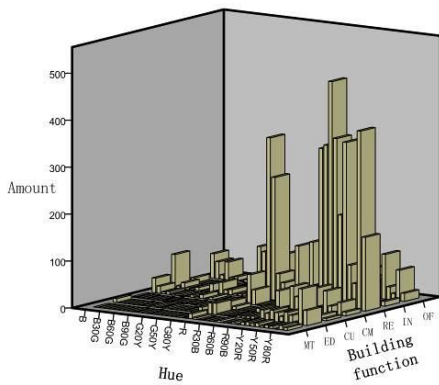

Figure 3: Building function distributed in hue.

## CONCLUSIONS

- There is a correlation between architectural functions and color attributes. The main features of the city are warm colors. Except for educational buildings, which tend to be red, other architectural functions tend to be yellow.
- The architectural color of the whole city shows a tendency of high brightness and low chroma. Each functional building has obvious tendency in color attributes.
- There is no one-to-one correspondence between Shanghai color types and architectural functions. Actually, in the real construction practice, the designer considers the relationship between color and function less than the space location and importance.

## REFERENCE

Fan, W., D. Meng, and D. Xu. 2014. Research progress of statistical correlation analysis methods. *Mathematical Modeling and Its Application* 3 (1): 1-12.

# A study on the fragmentation measurement of color space in historic areas: a case study of the old city chamber in Shanghai

Jiangbo Wang<sup>a</sup>, Aiping Gou<sup>b\*</sup>

<sup>a</sup> Department of Architecture, Nanjing Tech University, Nanjing, Jiangsu 211816, China

<sup>b</sup> Ecology Institute, Shanghai Institute of Technology, Shanghai 201418, China

\* aipinggou@hotmail.com

## ABSTRACT

Color in buildings in historic area embody the local color style and features, showing the local color culture and color context. However, new modern buildings and high-rise buildings have been built in many historical areas with different color far from the old ones. Therefore, the overall color style is gradually becoming fragmented. To accurately measure the fragmentation degree of splendid color landscape, the fragmentation measurement model was constructed. Traditionally, there are more white residential buildings and less yellow temple buildings. However, the research results show that yellow is the dominant color in the new buildings, blue and red are the most common, and there are also very few green ones. The area proportion of yellow block is the largest, which is close to 70% of the whole area. The shape fragmentation index of yellow system is the highest, which is 0.0688. The Yellow patches are the most fragmented in the historical and cultural landscape area of the old city chamber. It is necessary to combine urban renewal to reduce the degree of fragmentation of color in old city compartments and improve the integrity of their color features in the future. Some basic principles should be abided by, such as protecting the authenticity of color, maintaining the integrity of color, and continuing the memory of urban color when the historical landscape area is renewed and transformed.

**Keywords:** *historical area; fragmentation index; color patches; integrity*

## INTRODUCTION

Under the urbanization background, the traditional color in the historical areas has been destroyed. Color scattered showing high fragmentation (Jiao 2002). However, color is a very important element to exhibit the historical memory and cultural connotation as well as the city image. Shanghai old town is a typical case with the uniformity and integrity Chinese traditional the Jiangnan style architecture, surrounded by some European architectures. Enlightened by the fragmentation index in landscape ecology, the research quantifies the fragmentation of the color. At the same time, the current color

system is classified according to the degree of fragmentation, the functions of these variegated fragments in the old city was analyzed.

## DATA SOURCES AND RESEARCH METHODS

The study area is located in the Huangpu district of Shanghai, with a total area of about 199.72 hectares, which records the trajectory of Shanghai's urban development process for more than 700 years, including the rich material and non-material historical relics of various stages of the city, which embodies the evolving course of Shanghai city from the mid-Ming dynasty to the Republic of China. The study area includes traditional buildings of religious colors, residential houses, and commercial markets that have been preserved since the Ming dynasty. There are also some modern Chinese and Western styles of color buildings. Among them, there are private schools.

Data source: One is measured on site, and the color evaluation result is obtained by on-site evaluation according to google earth.

Research methods include color series classification, classification of color plaques in the old city.

## COLOR FRAGMENTATION METRICS

The color fragmentation index indicates the extent to which a certain type of color patch in a study area is split or separated by other color patches. According to the basic data such as the number of plaques, plaque circumference, average plaque circumference, plaque area, and average plaque area, the following six fragmentation indicators were used for quantitative analysis (Guo et al. 2004).

### Plaque diversity indicators include:

a) Color patch density index (PDK) refers to the ratio of the total number of color patches to their area in the study area. The larger the index, the higher the degree of fragmentation (Yang and Xiao 2003).

$$PD_k = \sum_{k=1}^n N_k / A \quad (k \text{ is a color patch in the study area}) \quad (1)$$

b) Color patch number index (FNK) reflects the degree of fragmentation of each type of color patch, reflecting the complexity of the color space structure (Guo et al. 2004).

$$FN_k = MPS (N_k - 1) / A \quad (2)$$

c) Color patch shape index (FSK) is closely related to the color plaque area of the study area. The larger the index, the more complex or flattened the color plaque shape, and the color plaque shape tends to be square when the index is close to 1 (Zhang et al. 2003).

$$FS_k = 1 - 1 / (\sum_{j=1}^n SI_{jk} / N_k) \quad (3)$$

$$SI_{jk} = P_{jk} / (4\sqrt{A_{jk}}) \quad (4)$$

d) Separation index (Nk) refers to the degree of dispersion or agglomeration of spatial distribution of different types of color patches in a study area (Luo et al. 2007).

$$Nk = \frac{A}{2A_k} \sqrt{\frac{n}{A}} \quad (k \text{ is a color patch type}) \quad (5)$$

**Type diversity indicators include:**

a) Shannon-Weaver diversity index ( $H_k$ ) refers to the probability that a certain color patch type in the study area appears in the entire study area (Li et al. 2002).

$$H_k = -\sum_{k=1}^n P_k \ln(P_k) \tag{6}$$

b) Color dominance index ( $D_k$ ) indicates the difference between the maximum value of the Shannon-Weaver diversity index and the actual calculated value (Xiong and Zhang 2012).

$$D_k = H_{\max} + \sum_{k=1}^n P_k \ln(P_k) \tag{7}$$

**RESEARCH RESULTS AND ANALYSIS**

Yellow accounts for the largest proportion of the entire color patch pattern in the study area, accounting for about 70% of the entire study area, so Yellow can be regarded as a matrix in the entire study area. The interval value of the color fragmentation degree of the old city compartment, and then the dominance index, which is a color fragmentation metric, is divided into three levels between 0 and 6, each level is separated by two values. The interval value of the dominant degree of the color system is used to find a color system with the highest degree of dominance to evaluate the degree of color fragmentation in the historical style of the old city. According to the dominance index, the proportion of yellow in the old city is more than half, and the degree of fragmentation is high, indicating that the overall fragmentation level of the old city is high (Table 1).

Fragmentation interval value	Fragmentation level
[0-2]	low
[2-4]	medium
[4-6]	high

Table 1: Old town color fragmentation level.

The color density index is sequentially Y, B, R, and G. The larger the density index of Y plaque, the higher the degree of spatial detachment and the highest degree of fragmentation. It is the most widely distributed in the study area and has the largest impact range. Y is the type of plaque with large fragmentation. The colors of B, R and G belong to the later-reformed buildings in the old city, and are scattered in the study area (Figure 1).

The size of the shape fragmentation index is: Y, R, B, G. The shape index of Y plaque is the largest, indicating that the plaque shape is the most complicated. Y occupies a stable situation in the old city; while the shape index of R and B plaques ranks second and third respectively, second only to Y. Plaque, and its average area is second only to Y plaque, which is widely distributed in the study area, and the shape of the plaque is more complicated. The shape index of G plaque is the smallest. At the beginning of this century, G was only used in commercial glass curtain wall, and the small scale used in the study area leads to the smallest shape index of the G plaque, so the shape is the most regular.

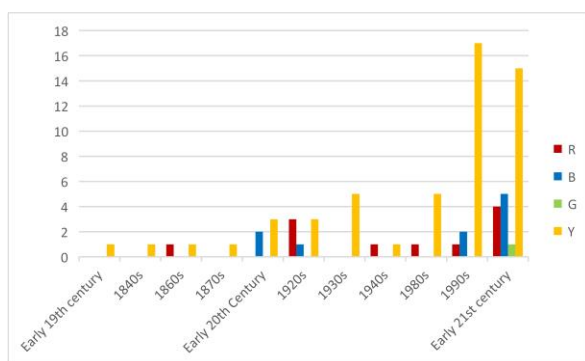

Figure 1: Number of blocks in each historical period.  
Source: Drawn according to data from [www.anjuke.com](http://www.anjuke.com).

## CONCLUSIONS

1) The yellow system plays a dominant position in the historical style of the old city. The concept of color diversity in modern life changes. Other color patches are invasive colors in the historical scene, so these color patches are fragmented to a low degree.

2) Yellow plaque has the highest development intensity and dominance in the landscape area. The largest color separation index is the green plaque, which shows that the development intensity of green plaque is the smallest. Compared with the yellow series, the spatial separation is the largest, which means that the development intensity is the highest, and it can be concluded that the yellow color is the traditional color in the old city.

3) The degree of fragmentation of color in the historical style area of the old town is high. The original color space features are lost, the color space fragmentation is intensified, the traditional features and values in the city are being lost, and the original culture and memory are gradually disappearing. The integrity of the color should be consistent with the traditional building interface, avoid blindly adopting some current popular colors, resulting in the fragmentation of the color space pattern of the entire historical scene, and maintaining the urban color integrity.

## REFERENCES

- Guo, M., M. Ma, Y. Xiao, et al. 2004. Analysis of oasis landscape fragmentation in arid area based on remote sensing and GIS —Taking Jinta oasis as an example. *Journal of Desert Research* 24 (2): 201-206.
- Jiao, Y. 2002. *Architectural appearance color performance and design*. Beijing: Mechanical Industry Press: 90.
- Li, Y., Y. Zhang, and S. Zhang. 2002. Landscape pattern changes and ecological effects of marsh wetland in Sanjiang plain. *Geography Science* 6: 677-682.
- Luo, P., K. Yan, H. Liu, and F. Zeng. 2007. Analysis of land use change and motivation in suburban agricultural areas —A case study of Gaoping district, Nanchong city, Sichuan province. *Resources Science* 4: 179-186.
- Xiong, W., and Z. Zhang. 2012. Green space system of Chongqing urban area based on RS and GIS. *Geospatial Information* 10 (1): 39-42.
- Yang, G., and Y. Xiao. 2003. Evaluation of forest landscape pattern and fragmentation —Taking Qilian mountain Xishui Nature Reserve as an example. *Journal of Ecology* 22 (5): 56-61.
- Zhang, S., G. Gong, L. Deng, et al. 2003. Analysis of landscape spatial pattern in hilly areas of western Sichuan. *Acta Ecologica Sinica* 23 (2): 380-386.

# Some flying ideas about color and light ambiences in built and natural environments

**Kazim Hilmi Or**

Private Office of Ophthalmology, Nisantasi, Istanbul, Turkey  
hilmi.or@gmail.com

## **ABSTRACT**

Ambience is subjective. It depends on individual's (visual) perception and culture of the of each individual. It is a psychological and social phenomenon. Feelings like being in a nice ambience is society and individual dependent. When they change the ambience perception changes, also. Visual and color perception are illusions. Scientific illusions can show the discrepancies between perception and physics. Beauty or ambience in illumination and light color composition of cities and their change is dependent on the change in functions of humans, changes in lighting and imaging technologies and the physiologic illusions and nature of humans. The ambience of cities due to illumination and color should be in accordance with human functionality and physiologic needs.

**Keywords:** *illumination technologies, color perception, visual perception, human eye physiology, beauty in accordance with function*

## **WHAT IS BEAUTY?**

What is "beautiful"? All the golden ratio and rules of "beauty" depends on functionality. If something is a functional and useful feature in nature or in the life (lifespan) of humans, it becomes "beautiful" over time. If desired functions change over time, the "beauty" perception changes also. This a process which is time dependent. When needs and necessities in human life come to new levels it also changes the taste. Otherwise there should be no changes in artistic tastes.

So beauty is dependent of functionality at a specific time in the life of humans. It has also to be compatible with the life going on. So art and beauty perception are not independent of technique, science and life itself at a specific moment in human life.

## **AMBIENCE**

Ambience is subjective. It depends on individual's (visual) perception and culture of the of each individual. It is a psychological and social phenomenon. Feelings like being in a nice ambience is society and individual dependent. When they change the ambience perception changes, also.

## **VISUAL AND COLOR PERCEPTIONS**

Visual and color perception are illusions. They are created in the brain and not in the eye. Visual and color perception can be created in some instances even without any input in the eye (dreams, synaesthesia, hallucinations, etc.). So, perception of images and colors cannot be explained directly physically. Scientific illusions can show the discrepancies between perception and physics.

## **LIGHTING TECHNOLOGY CHANGES AND ITS INFLUENCE ON AMBIENCE**

Until about 200 years ago the cities had only artificial lighting with candles. The light of candles had only the wavelengths of flames. Over time with the invention of electrical illumination the spectra of artificial lighting has changed. Today one can have even daylight light properties at darkness or at night. The availability of new spectra allows the mind and the taste to have new horizons. Illumination technologies have changed in the last decades rapidly. New LED technologies allow any color temperature and any color of artificial lighting with relatively simple devices at financially affordable prices with less energy consumption than some decades ago. So illumination and its color composition can be managed as desired.

## **HUMAN EYE PHYSIOLOGY AND PERCEPTION BY DIFFERENT ILLUMINATION MODALITIES**

Humans eye physiology best perception wavelengths in darkness or in nights have a shift to blue (so called blue shift). These is an adaption (or a change due to Darwin's theory) to seeing in natural darkness at night. At evening and at night natural illumination spectrum is shifted also to blue. New illumination technologies change the light available at night.

Due to human physiology one can only see a color on an object when it is given in the spectra of illumination luminaire. So the perception changes with illumination. New technologies like smart cities, smart illumination, very new technologies like street illumination on smart phone signal detection change the lighting in the cities and the corresponding human perception rapidly. On the other hand augmented reality and virtual reality with new visual and pseudo-color perceptions may change all the conventional visual perceptions.

## **CONCLUSION**

So, beauty or ambience in illumination and light color composition of cities and their change is dependent on the change in functions of humans, changes in lighting and imaging technologies and the physiologic illusions and nature of humans. The ambience of cities due to illumination and color should be in accordance with human functionality and physiologic needs.

# Color and Psychology





# Effect of intensity of short-wavelength light on human alertness

Jing Lin\*, Stephen Westland

University of Leeds, UK

\* cm14jl@leeds.ac.uk

## ABSTRACT

Short-wavelength light is known to have an alerting effect on human alertness. This study evaluates the acute alerting ability of short-wavelength light of three different intensities (40 lx, 80 lx and 160 lx). Eight subjects participated in a 60-minute exposure protocol for four evenings, during which electroencephalogram (EEG) as well as subjective sleepiness data were collected. EEG power in the beta range was significantly higher after subjects were exposed to 160 lx light than after they were exposed to 40 lx, 80 lx light or remained in darkness. Also, the alpha theta was significantly lower under 160 lx light than in darkness. These results show that the effect of intensity on alertness is not linear and further work should be done to investigate the threshold intensity that is required to produce an alerting effect.

**Keywords:** *short-wavelength light, alertness, EEG*

## INTRODUCTION

Light has been shown to exert strong non-visual effects on a range of biological functions such as the regulation of human circadian system. Exposure to light in the evening and nighttime, especially of short-wavelength (but not necessarily limited to short wavelengths), has been shown to lead to an increase in alertness in humans. This effect is suggested to be related to circadian disruption. Circadian disruption is associated with reduced levels of the hormone melatonin and is primarily mediated by activation of the intrinsically photosensitive retinal ganglion cells which respond to short-wavelength light most strongly. Exposure to light in the evening can inhibit the production of melatonin which otherwise would naturally build-up in the body during the late-evening hours.

Short-wavelength light is becoming a critical safety concern. For example, there has been concern about home lighting in the evening, where warm tungsten light is increasingly being replaced by cooler solid-state lighting; the use of emissive electronic displays may also be responsible for the increasing sleep problem (Chang et al. 2015). Differences in the properties of lighting were shown to affect individuals in various ways. Past studies have tried to define and quantify the timing,

illuminance levels, exposure duration and wavelength distribution of the light required to evoke alerting responses (Cajochen 2007).

A study has looked at how three different illuminances ranging from 3 lx to 9100 lx affect EEG activity over 6.5 hours of exposure, and a dose-response relationship was found in subjective alertness and EEG power (Cajochen et al. 2000). Some other such studies have also demonstrated a non-linear relationship between light intensity and circadian shifts (Zeitzer et al. 2000). It is generally agreed that brighter light has a stronger alerting ability than dimmer light. However, there is no consensus yet about the threshold of light intensity needed to produce these effects.

## EXPERIMENTAL DESIGN

The alerting effect of intensity of light in humans has so far received little attention. This work is concerned with exploring the threshold intensity of light needed to evoke acute alertness responses in humans at nighttime. The objective, specifically, is to investigate the effect of three intensities (40 lx, 80 lx and 160 lx) of a short-wavelength light ( $\lambda_{\max} = 475$  nm), compared to remain in darkness (< 1 lx), on human alertness during the evening.

Eight participants ( $28 \pm 3.6$  years, including five females) were recruited for the within-subject, four-session study. All of them went through a pre-screening procedure where individual sleep/rise time was collected and the daily consumption of nicotine, caffeine and alcohol was reported. An information sheet was given and participants were asked to refrain from caffeine and alcohol intake 3 hours prior to the experiment, and to try to maintain a regular, constant sleep schedule during the entire experimental period.

Light was delivered through 12 mounted in the ceiling of a room with white walls and grey carpets. Participants were asked to sit under the light whilst reading, with a white table in front of them. Four light settings were used: a dim (2000 K, < 1 lx) and three short-wavelength lighting conditions. The short-wavelength condition had a peak at about 480 nm and was approximately Gaussian with a half-width half-height of 35 nm. Three intensities were 40 lx, 80 lx and 160 lx ( $\pm 1$  lx).

Each participant completed four sessions over four nights, all starting at the same time (8 pm). Participants were fitted with EEG electrodes prior to the start of the exposure. During each evening study EEG was continuously recorded over 60 minutes. Under the dim condition, participants were kept in the dim light for 60 minutes. Under the blue condition, test lights were energized for 40 minutes, preceded by a 20-min dim (< 1 lx) period. Subjective was rated every 20 minutes. Participants were reminded to write down their scores on the Karolinska sleepiness scale (KSS) questionnaire at the 20th, 40th and 60th minute of each session (Figure 1).

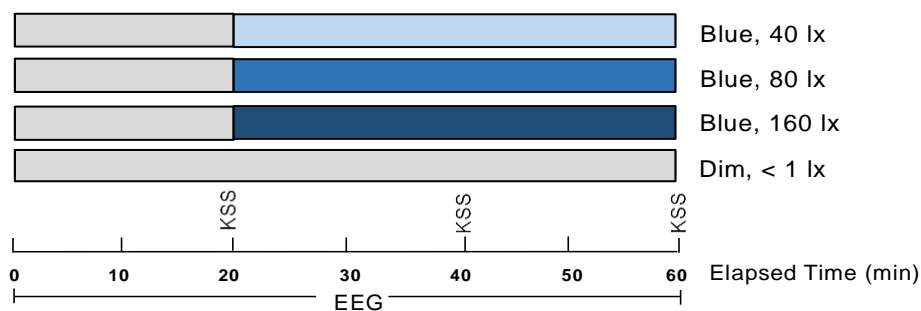

Figure 1: Experimental design.

## RESULTS

EEG measures collected were averaged to produce overall EEG PSD, and then grouped into the following frequency bins: 5-9 Hz (theta alpha), 8-9 Hz (lower alpha), 11-13 Hz (higher alpha), and 13-30 Hz (beta). In each frequency range, EEG power averaged over the 40 minutes under test lighting was normalized to the initial 20 minutes of dim light period. One-way analysis of variance (ANOVA) was performed using the normalized power in each of the frequency ranges studied. Post-hoc t-tests (with Bonferroni corrections) were used to further compare the significance between lighting conditions.

One-way ANOVA revealed a close to significant main effect of lighting condition in the normalized theta alpha ( $F_{3, 28} = 2.785$ ;  $p = 0.059$ ) and a significant main effect of lighting condition in beta ( $F_{3, 28} = 7.571$ ;  $p = 0.001$ ). No significant difference was observed in lower alpha ( $F_{3, 28} = 0.477$ ;  $p = 0.701$ ) or higher alpha ( $F_{3, 28} = 0.385$ ;  $p = 0.765$ ) ranges. Post-hoc pairwise comparisons found significant differences between dim and 160 lx, 40 lx and 160 lx, 80 lx and 160 lx in beta range. Power in theta alpha was lower after exposure to 40 lx and 160 lx blue lights than after remaining in the dim condition. Power in beta range was significantly higher after exposure to 160 lx blue lights than after exposure to the other three lighting conditions. Compared to dim, exposure to 160 lx blue light has also reduced lower alpha power and increased high alpha power, although these differences did not reach statistical significance ( $p > 0.05$ ).

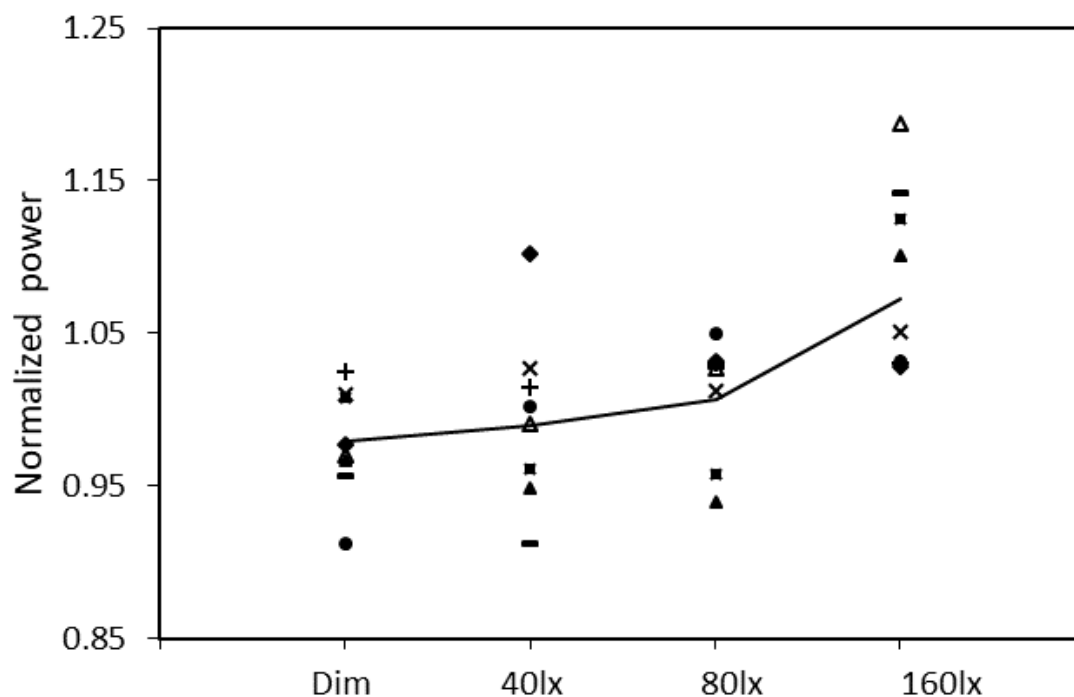

Figure 2: Individual EEG power values in beta range (the same symbol indicates the values obtained from the same participant).

Subjective sleepiness was evaluated using the Karolinska sleepiness scale (KSS), a self-reporting scale that ranges from 1 ('extremely alert') to 9 ('very sleepy, fighting sleep') (Shahid et al. 2012). This scale has previously been shown to be sensitive to changes in sleepiness and the alerting effects of lights (Lockley et al. 2006).

The KSS was rated three times (at the 20th, 40th, and 60th min) during each session. Subjects were asked to rate themselves from 1 to 9, according to their sleepiness. Mean scores over the experimental condition were normalized to the initial dim session.

ANOVA revealed a significant difference between dim and 160 lx conditions. Mean score in 160 lx condition was significantly lower than score in dim condition (a lower KSS score means more alertness). Mean scores under 40 lx and 80 lx conditions were lower than score under the dim, and higher than score under the 160 lx condition, although these differences did not reach statistical significance ( $p > 0.05$ ).

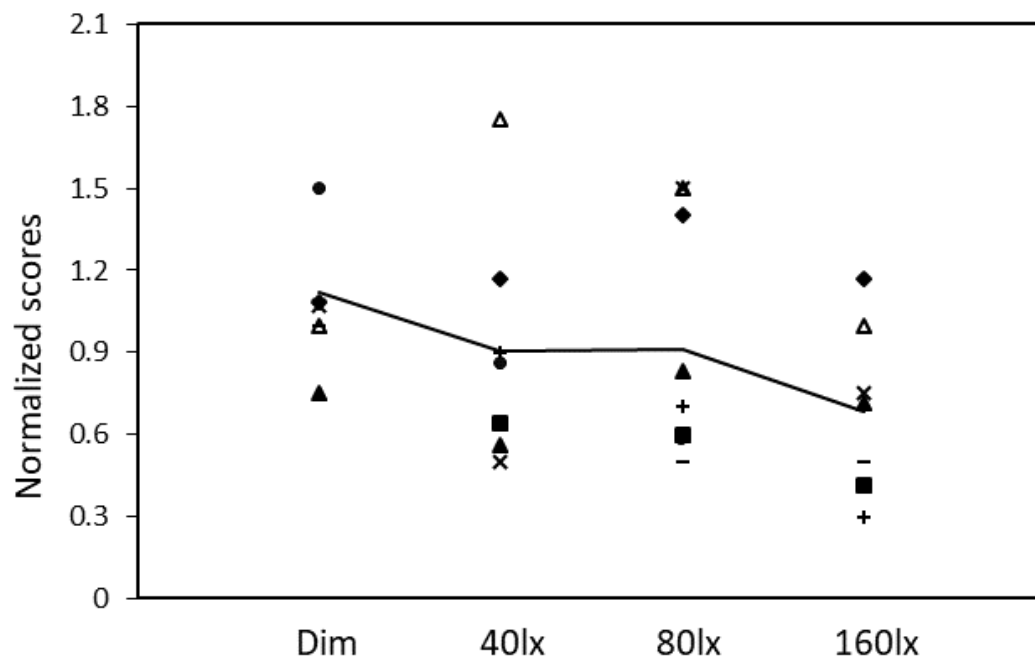

Figure 3: Individual KSS scores (the same symbol indicates the values obtained from the same participant).

## CONCLUSIONS

This study provides some evidence that short-wavelength light exposure in the evening can increase human alertness and that this can occur relatively quickly (even though some other studies have suggestion that melatonin inhibition, for example, may have a longer time course). Both objective and subjective results also suggest that for the lighting conditions tested in the present study, light of higher intensity has a stronger alerting effect than light of lower intensity. These findings, in themselves, do not enable a threshold effect to be identified. However, the methodology described in this study may provide a basis for future on-going work to address this question explicitly.

## REFERENCES

- Cajochen, C. 2007. Alerting effects of light. *Sleep Medicine Reviews* 11 (6): 453-464.
- Cajochen, C., J. M. Zeitzer, C. A. Czeisler, and D. J. Dijk. 2000. Dose-response relationship for light intensity and ocular and electroencephalographic correlates of human alertness. *Behavioural Brain Research* 115 (1): 75-83.
- Chang, A. M., D. Aeschbach, J. F. Duffy, and C. A. Czeisler. 2015. Evening use of light-emitting eReaders negatively affects sleep, circadian timing, and next-morning alertness. *Proceedings of the National Academy of Sciences* 112 (4): 1232-1237.
- Lockley, S. W., E. E. Evans, F. A. Scheer, G. C. Brainard, C. A. Czeisler, and D. Aeschbach. 2006. Short-wavelength sensitivity for the direct effects of light on alertness, vigilance, and the waking electroencephalogram in humans. *Sleep* 1; 29 (2): 161-168.
- Shahid, A., K. Wilkinson, S. Marcu, and C. M. Shapiro. 2012. Karolinska sleepiness scale (KSS). In: *STOP, THAT and One Hundred Other Sleep Scales*, A. Shahid, K. Wilkinson, S. Marcu, and C. M. Shapiro, eds. New York: Springer-Verlag, 209-210.
- Zeitzer, J. M., D. J. Dijk, R. E. Kronauer, E. N. Brown, and C. A. Czeisler. 2000. Sensitivity of the human circadian pacemaker to nocturnal light: melatonin phase resetting and suppression. *The Journal of Physiology* 526 (3): 695-702.

# Color preference and emotion among Japanese students

**Mahshid Baniani**

University of Tsukuba, Japan  
m\_bani@hotmail.com

## ABSTRACT

The present research explores how Japanese elementary, junior high, and high school students respond towards color and emotions through a 3-task-experiment. Elementary school students associated black with the negative facial emotions ( $P < 0.05$ ). Subjects across all age groups wanted their bedroom to be white ( $P < 0.05$ ), while 57.5% of the elementary school students found white to be an unhappy color in the color assessment task. Therefore, it was concluded that context-less color preferences does not necessarily generalize to objects even among elementary school students. In sum, it was observed that children as young as 7 can associate colors and emotions.

**Keywords:** *color preference, children, facial expressions*

## INTRODUCTION

Color is not just represented in vision, and it can evoke emotional responses, aesthetic judgments, and associations to objects and concepts (Brooker and Franklin 2016). Color plays an important role in self-presentation and in impression formation. Individuals not only show specific color preferences but also attribute emotional characteristics to colors in consistent ways from school age on (e.g. Valdez and Mehrabian 1994). Although there are numerous studies on the association between colors and emotions among adults, little is known about how young children feel about color. The present research extends previous work, and will explore how Japanese children respond towards color and emotions. The important question here is whether younger children can detect a relationship between a color and an emotional expression and if there are any changes across development as they grow older.

## METHOD

### Participants

47 Japanese elementary school students (23 girls and 24 boys) aged from 7 to 12 ( $M = 8.11$ ), 39 junior high school students (19 girls and 20 boys) aged between 13 and 15 ( $M = 14.1$ ), and 39 high school students (19 girls and 20 boys) aged between 16 and 18 ( $M = 17.1$ ) were subjects of this study. They were all enrolled in public schools in Tsukuba Science City, Japan.

### Procedure

The experiment was conducted between November and December 2018, and consisted of the following three tasks:

1. A questionnaire was given to the subjects, and they were asked about the color they liked the most/least, the color they would like to wear the most/least, the main color they would want their bedroom to be, and the color of their favorite toy (for younger students) or object (in the case of older students).
2. They were presented with 8 emotional facial expressions (see Figure 1) each presented in 11 different colors (red, orange, brown, yellow, green, blue, purple, pink, gray, black, and white), and were asked to select the most appropriate color representing the given emotion.

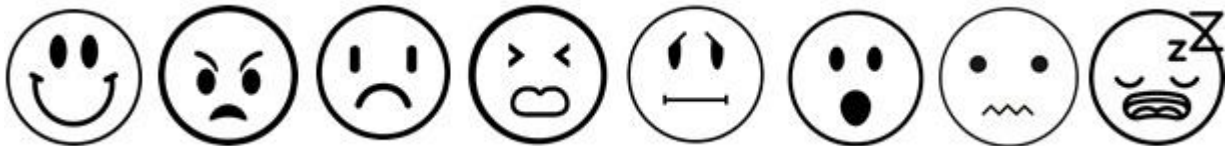

Figure 1: Facial expressions: happy, angry, sad, disgusted, guilty, surprised, anxious, and tired.

3. They were presented with 11 different colored pieces of cardboard (the same colors as step 2), and were asked to rate how they feel about the represented color on a five-point Likert scale from very unhappy to very happy.

The experiment was conducted in groups among older students (junior high school and high school students), and individually among elementary school students.

## RESULTS

### Subjects and preferences

This section focuses on the first task of the questionnaire where subjects write their color preferences. Please keep in mind that in this section of the experiment subjects could write any color they wanted. Table 1 shows the 3 most written colors in each category.

Red is among the most favorite color of all age groups and pink/purple among the least favorite colors ( $P < 0.05$ ). Interestingly, it was boys who listed pink (or purple) as their least favorite color. Additionally, white is the most wanted color for the bedroom, which was seen in a previous research as well (Baniani and Yamamoto 2015). Black, red, blue, and white are among the favorite colors to wear, but dark/brown, pink and purple are the least favorite colors to wear. Once again, it was the boys who didn't want to wear pink or purple ( $P < 0.05$ ).

	Most favorite color			Least favorite color			Wanted color for bedroom		
Elementary	Red	Gold	Blue	Pink	Black	Gray	White	Light Blue	Gold
%	21.3	21.3	10.6	42.6	23.4	8.6	23.4	17.2	8.6
Junior High	Blue	Red	Orange	Brown	Dark Brown	Pink	White	Light Blue	Green
%	12.8	12.8	10.3	20.5	17.9	15.4	58.9	10.3	7.7
High	Red	Light Blue	Navy	Purple	None	Brown	White	Light Blue	Beige
%	17.9	10.3	10.3	23	20.5	12.8	35.9	12.8	12.8

	Preferred color to wear			Least preferred color to wear			Color of favorite toy/object		
Elementary	Black	Red	Blue	Pink	Black	Red	Red	Blue	Purple
%	19.2	17.2	14.9	29.8	25.5	14.9	17.2	17.2	12.8
Junior High	White	Blue	Black	Brown	Dark Brown	Pink	Red	Black	Yellow
%	25.6	15.4	12.8	17.9	15.4	15.4	15.4	12.8	10.3
High	Black	White	Red	Brown	Dark Brown	Purple	Black	Yellow	White
%	25.6	23	10.3	15.4	15.4	12.8	17.9	15.4	12.8

Table 1. Subjects and color preferences.

### Emotional facial expression and colors

In this task, subjects had to associate each facial expression with a color. As can be observed from Figure 2, elementary school students have chosen a greater variety of colors linked to an emotion compared to junior high and high school students ( $P < 0.05$ ). However yellow, red, and blue are associated with happy, angry, and sad respectively among all age groups. Additionally, elementary school students have associated black with all the negative emotions ( $P < 0.05$ ). From Table 1, it can further be observed that black is amongst the least favorite colors.

Disgusted is associated with green, anxious with red, guilty with purple and gray, and surprised with yellow among junior high and high school students. Tired is associated with black and white among elementary and junior high school students, and with gray among high school students.





Figure 2: Emotional facial expressions and colors.

**Color assessments**

As can be observed from Figure 3, elementary school students are the only subjects that have given every assessment to all the colors from (very) unhappy to (very) happy ( $P < 0.05$ ). For example, in case of yellow, although 12.8% of the elementary school subjects found it as an unhappy color, no junior high school or high school student found them to be unhappy color. On the contrary, 12.8% of the elementary school students found gray to be a happy color while no junior high or high school student found it to be a happy color. This may be linked to all the experiences elementary school students have during their early years as they are more surrounded by colors than older children. Additionally, junior high school and high school students found white to be a happier color than elementary school students did ( $P < 0.01$ ).

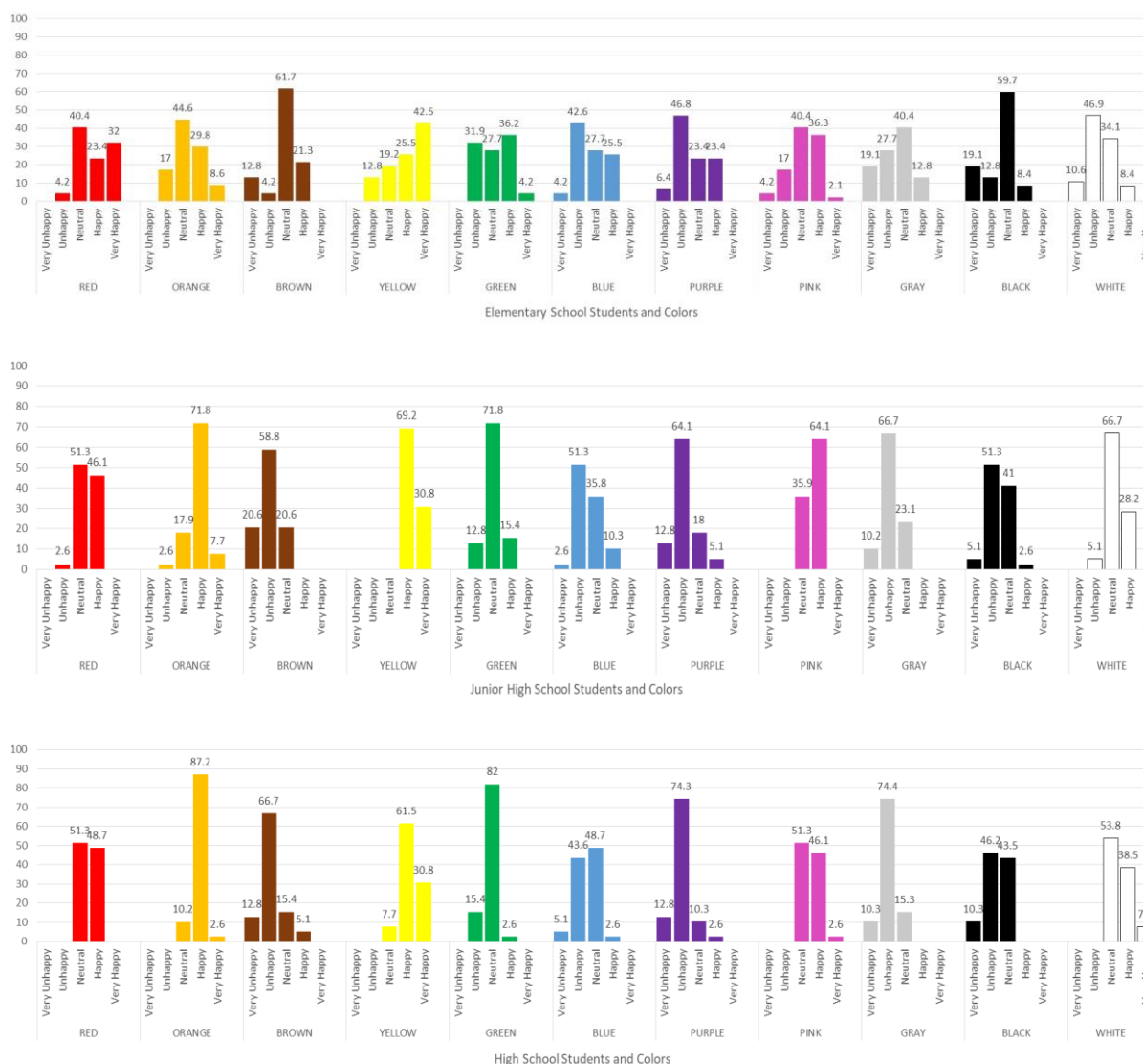

Figure 3: Color assessments of the subjects.

### DISCUSSION AND CONCLUSIONS

The purpose of this research was to identify how Japanese students perceive colors and if there are any changes across development as they grow older, which was conducted through a 3-task-experiment.

Subjects associated happy face with yellow, angry face with red, and sad face with blue ( $P < 0.05$ ). Numerous studies have reported that adults and children associate blue with sadness (Collier 1996, Karp and Karp 1988). The link of yellow with happiness has been found in work with adults (Collier 1996) and with children (Karp and Karp 1988). Moreover, elementary school students associated black with all the negative facial emotions ( $P < 0.05$ ). Burkitt et al. (2003) concluded that black tends to be the most frequently chosen color for completing drawings of the negatively characterized topics. Similarly, from Table 1, it was observed that black is among the least favorite colors of the subjects.

Furthermore, compared to junior high and high school students, elementary school students not only had more color varieties regarding each facial emotion, but also they were the only subjects that gave every assessment to all the colors from (very) unhappy to (very) happy ( $P < 0.05$ ). The average age for the elementary school subjects was 8.11, while it was 14.1 and 17.1 for junior high and high school students. This age gap shows a possible influence of culture, education, and environment on how children perceive color as they grow up. It would have been better to have adult subjects to further prove this point. Additionally, the subjects of this experiment were Japanese. It would be interesting to have subjects from other nationalities and cultures to see how different the results are.

Subjects wanted the main color of their bedroom to be white, followed by light blue. Interestingly, 57.5% of the elementary school students found white to be a (very) unhappy color. From this result, it can be concluded that context-less color preferences does not necessarily generalize to objects even among elementary school students, and even if they may find white as an unhappy color, they still would want their bedroom to be white.

Red and blue were among the subjects' favorite colors and preferred colors to wear while dark colors such as brown and black were among least favorite colors. Additionally, pink and purple were among least favorite colors and least preferred colors to wear among boys. When I asked their reason for not wanting to wear pink or purple, their reply was "it's a girl's color. Boys don't wear pink".

In sum, consistent with other development studies, it was observed that children as young as 7 can associate colors and emotions, and context-less color preferences do not necessarily generalize to objects.

## REFERENCES

- Baniani, M., and S. Yamamoto. 2015. A comparative study on correlation between personal background and interior color preference. *Color Research and Application* 40 (4): 416-424.
- Brooker, A., and A. Franklin. 2016. The effect of colour on children's cognitive performance. *British Journal of Educational Psychology* 86: 241-255.
- Burkitt, E., M. Barrett, and A. Davis. 2003. Children's colour choices for completing drawings of affectively characterized topics. *Journal of Child Psychology and Psychiatry* 40 (3): 445-455.
- Collier, G. L. 1996. Affective synesthesia: extracting emotion space from simple perceptual stimuli. *Motivation and Emotion* 20: 1-32.
- Karp, E. M., and H. B. Karp. 1988. Colour associations of male and female fourth-grade school children. *Journal of Psychology* 122: 383-388.
- Valdez, P., and A. Mehrabian. 1994. Effects of colour on emotions. *Journal of Experimental Psychology* 123: 394-409.

# A method for scaling impressions of a scene

Tzu Hao Liu<sup>a</sup>, John Hutchings<sup>b</sup>, Ming Ronnier Luo<sup>a,b\*</sup>

<sup>a</sup> State Key Laboratory of Modern Optical Instrumentation, Zhejiang University, Hangzhou, China

<sup>b</sup> School of Design, University of Leeds, UK

\* m.r.luo@leeds.ac.uk

## ABSTRACT

This paper describes the results of an experiment to evaluate people's impressions of a live landscape scene, the famous West Lake in Hangzhou, China. Seventy students in different academic backgrounds participated the project. The goals of this study were to find a method to evaluate the perception of a live scene, and to reveal differences for subjects from different backgrounds. In the experiment, students sat together and looked at the lake from one similar location. The students were asked to give their judgement of the scene by answering a questionnaire. The results were analyzed to find the main components describing the scene. The novel features in the work were the assessment of scenery using the affective engineering technique, to perform the experiment outdoor using a large number of people, to have observers from various backgrounds, and to provide a new teaching method for colour science and colour design.

**Keywords:** *colour design, Kansei engineering, appearance, perception*

## INTRODUCTION

In industrial design, affective or Kansai engineering techniques are commonly used to help designers in the creation of products. The results are valuable in obtaining consumer preferences, making product development more consistent. For example, customers may, through experience and habit, make choices of a particular feature of commodity appearance. Sensory colour evaluations can be carried out using a colour order system and colour atlas. Kobayashi (1981) found that colours can be displayed using two axes, hard-soft and warm-cool. Green-Armytage (2002) uses defined colour zones: vivid, strong, deep, dark, black, white, pale, light, and bright when classifying colours. In Ou et al. (2004) research on colour emotion, 11 scales were used to investigate colour preferences. They found they can be categorized into three groups, colour temperature, colour activity and colour weight. Hutchings et al. (2013) stated that the appearance of a material consists of visual structure, and distributions of surface texture, colour, gloss and translucency, together with their temporal properties. Scene illumination provides light and shade to define the volume and texture of the scene. For total appearance properties of the design, Hutchings and Luo (2010) used five expectations which are

visually assessed safety, identification, usefulness, pleasantness, and satisfaction when judging a person, object or space. Wei et al. (2015) used the similar method to assess juice packages using images and found 4 terms to be most suitable (colour harmony, liking, quality and freshness). The above research methods and phrases were used as references in this paper. Note that all perceptions and scales were set in Chinese and all subjects were Chinese.

The scene studied in this paper, West Lake, is one of the most famous historical tourist attractions in China. Its popularity is not confined to China but to the Chinese community all over the world. The live scene we chose for the experiment included the famous Baochu Pagoda and the Xiling Bridge. And the location of the subjects was the famous Sudi (苏堤) causeway.

## EXPERIMENT

In this experiment, students were asked to evaluate their impressions of a real landscape scene of West Lake in Hangzhou, China. Figure 1 illustrates the scene studied. Seventy students participated in a taught module of basic colour science. They came from a wide number of disciplines, including science, engineering, art and design, medicine, and social science, of which 33 were males and 37 were females. The students were mainly first and second year undergraduates, having an average age of 20.1 and a standard deviation of 0.97. The module took place in the spring term of China, after the course of colour design.



Figure 1: The scene assessed by the students at a corner of West Lake.

In the experiment, the whole scene was divided into 5 parts, the sky, lake water, the pagoda, trees and mountains, and the bridge (see Figure 1). Students were asked to sit together and look at the live scene at West Lake from a similar location. The time of the experiment was in the morning of March 23, 2019. It was a beautiful Saturday morning, sun was shining with mild wind and cherry blossom on the trees.

The main research work was divided into 2 parts. For part I, each student was asked to focus on a live scene and to judge the 6 elements (five parts and the whole scene) using the perceptions mentioned later using a 4-point category scale, e.g. (-2) cool, (-1) a little cool, (1) a little warm, (2) warm. The attributes were chosen from the results of a pilot-study that took place before the experiment. In this study students were asked to list adjectives describing specified objects in the given 10 popular computer images of West Lake. The top 13 most frequently used pairs of words were used as the evaluation attributes for each part. Nine word pairs were common to all objects. They were attractive-not attractive, warm-cool, beautiful-ugly, bright-dark, clear-hazy, harmonious-disharmonious, pleasant-unpleasant, tranquil-stormy, and peaceful-not peaceful.

Part II was a colour appearance assessment. Luo et al.'s method (1991) for scaling colour in terms of lightness, colourfulness and hue composition was used. Each subject looked at a particular object and scaled each attribute on a white paper. The white paper was used as a reference having a lightness of 100. The lightness of each object were scaled against the reference white. Each object's colourfulness was scaled against the white paper having a colourfulness of zero (neutral colour). For scaling hue, each colour is specified in terms of 4 unitary hues red, yellow, green and blue, which form 2 pairs of complementary hues (R-G and Y-B). An orange colour is located between red and yellow and could have a 60% of red and 40% red. So, his or her result for this colour will be 60R40Y.

## RESULT AND DISCUSSION

### Observer inter-variability

Initial analysis was carried out in terms of observer inter-variability analysis. Each observer's data were used against the mean visual results. The root-mean-square (RMS) was used to indicate the agreement. For a perfect agreement, the RMS should be zero.

Figure 2 shows the RMS values plotted against 13 scales. The results showed that the attribute "peaceful-not peaceful" gave most consistent results, and there were similar results for "attractive-unattractive", "comfortable-uncomfortable" and "balanced-unbalanced". However, "unconfined-confined" and "warm-cool" gave the least consistent results. Also, the variation for the attribute "peaceful-not peaceful" was the smallest, which means that it is the most consistent amongst all the 13 attributes studied. And, due to typesetting reasons, only the first word is used to represent the word pairs in the figures and tables below.

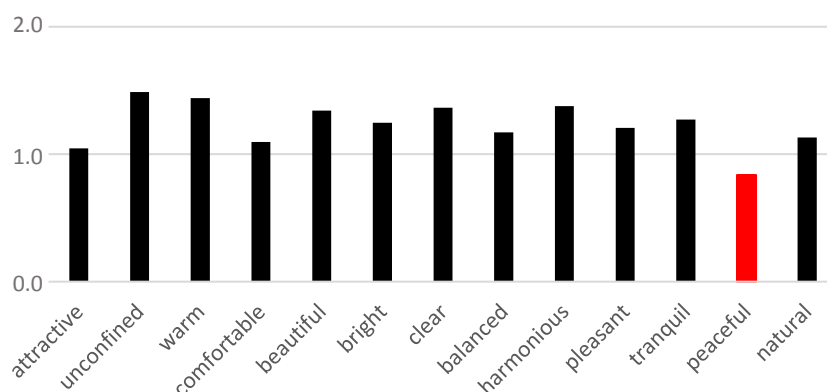

Figure 2: Plot of RMS against 13 scales.

### Comparing results between different observer groups

Data analyses were also carried out to reveal the difference between different observer groups, i.e. between male and female groups, and between scientist and artist backgrounds. Figure 3 plots the mean results of 13 attributes between male and female, and between scientist and artist subjects, respectively. They had R values of 0.733 and 0.843, respectively. This implies strong correlation between two genders and between two backgrounds, respectively.

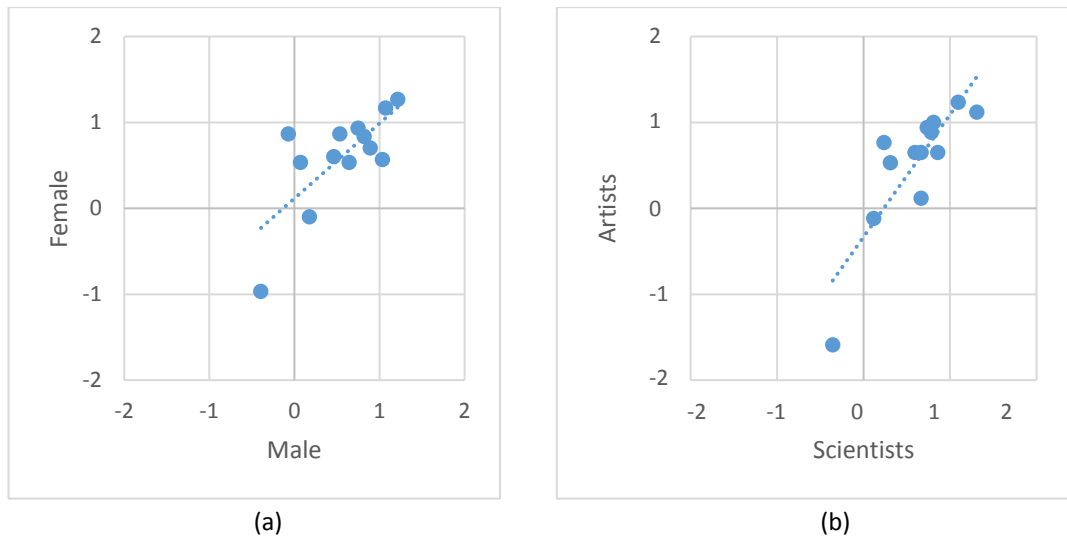

Figure 3: The mean result for each attribute plotted (a) between male and female and (b) between scientists and artists.

### Factor analysis

In this section, only the whole scene results are reported. The individual component results will be given elsewhere due to the shortage of space. The factor analysis was carried out and the results are given in Table 1. Note that it is an extraction method using principal component analysis together with an orthogonal rotation technique. Factor 1 accounts for 22.9% of the variance, while 19.6% is explained by factor 2.

These factors were named Harmony and Peaceful. The former includes the terms of “harmonious-disharmonious”, “clear-hazy”, “warm-cool”, “bright-dark”, “unconfined-confined”, and “balanced-unbalanced”, and the latter includes the terms of “peaceful-not peaceful”, “natural-unnatural”, “tranquil-stormy”, “attractive-unattractive”, and “comfortable-uncomfortable”. Figure 4 clearly shows the attributes’ position in the multidimensional space and they are clearly divided into two factors. They represent the typical words to describe the beauty of West Lake. Note that the attributes “beautiful-ugly” and “pleasant-unpleasant” have strong relation in both components, but they are not placed in either group. This is because the pleasantness perception of West Lake is closely related to two both components, peaceful and harmony.

Component	1 (Harmony)	2 (Peaceful)
Variance	22.9%	19.6%
Harmonious	0.664	0.035
Clear	0.661	0.024
Warm	0.622	-0.048
Bright	0.598	0.306
Unconfined	0.588	0.227
Balanced	0.587	-0.085
Pleasant	0.542	0.525
Beautiful	0.490	0.488
Peaceful	0.087	0.782
Natural	0.092	0.624
Tranquil	-0.049	0.588
Attractive	0.011	0.526
Comfortable	0.070	0.498

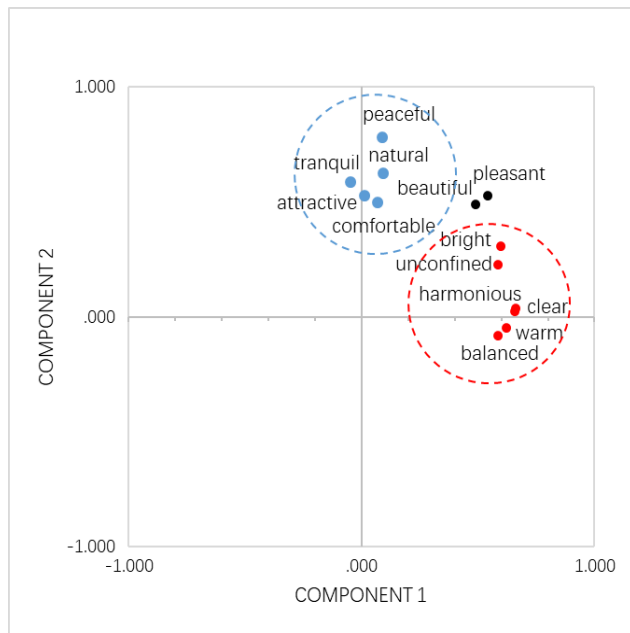

Table 1: The results from the factor analysis.

Figure 4: Attributes in the component space.

### Colour appearance assessment

For specifying colour appearance, the hue composition, lightness, and colourfulness scores from all observers were averaged and are summarized in Table 2 for each part in the scene.

Objects	Sky	Lake	Pagoda	Trees and mountains	Bridge
Hue composition	9G91B	79G21B	5Y95G	32Y68G	17R83Y
Lightness	81	61	22	54	33
Colourfulness	48	47	22	60	34

Table 2: The statistical average of the position of the objects in the colour space.

### CONCLUSION

The novel features in the work were the assessment of real scenery using the affective engineering technique, to perform the experiment outdoor using a large number of subjects, and to have observers from various backgrounds. This study has also provided a practical session on colour design, a part of the basic colour science module.

The results showed 5 colours represented the different parts of the West Lake scene, which can be described as two overall impressions of harmony and peaceful.



**REFERENCES**

- Green-Armytage, P. 2002. Colour zones: explanatory diagrams, colour names, and modifying adjectives. In: *AIC 2001, Proceedings of the 9th Congress of the International Colour Association*, Rochester, NY, 24-29 June 2001, R. Chung and A. Rodrigues, eds. Bellingham, WA: SPIE, The International Society for Optical Engineering, vol. 4421, 861-864.
- Hutchings J. B., and M. R. Luo. 2010. Quantification of scene expectations and impact. *Journal of the Chinese Institute of Engineers* 33 (5): 691-695.
- Hutchings, J. B., M. R. Luo, and W. Ji. 2013. Food appearance quality assessment and specification. In: *Instrumental assessment of food sensory quality*, D. Kilcast, ed. Cambridge, UK: Woodhead Publishing Series in Food Science, Technology and Nutrition, 29-52.
- Kobayashi, S. 1981. The aim and method of the colour image scale. *Color Research and Application* 6 (2): 93-107.
- Luo, M. R., A. A. Clarke, P. A. Rhodes, A. Schappo, S. A. R. Scrivener, and C. J. Tait. 1991. Quantifying colour appearance: Part I – LUTCHI colour appearance data. *Color Research and Application* 16 (3): 166-180.
- Ou, L. C., M. R. Luo, A. Woodcock, and A. Wright. 2004. A study of colour emotion and colour preference. part ii: colour emotions for two-colour combinations. *Color Research and Application* 29 (4): 292-298.
- Wei, S. T., L. C. Ou, M. R. Luo, and J. B. Hutchings. 2015. Psychophysical models of consumer expectations and colour harmony in the context of juice packaging. *Color Research and Application* 40 (2): 157-168.

# Colour influence of input button on user's pressing motivation: analysis using different background colour and shape of button

Saori Kitaguchi, Yoshikazu Mizutani, Sumako Suzuki, Tetsuya Sato\*

Kyoto Institute of Technology, Japan

\* tsato@kit.ac.jp

## ABSTRACT

The aim of this study is to confirm the colour influence on user's motivation to press an input button on touch screen device. In order to obtain a deeper understanding of the influences, the two visual evaluation experiments (Experiment I and II) were conducted. Experiment I was to investigate the influence of a background colour, and Experiment II was to investigate the influence of a shape of buttons. The results of Experiment I indicated that the colour of the most frequently pressed button was red for pale background colours condition and yellow for deep background colour condition. The result of Experiment II indicated that the colour of the most frequently pressed button was yellowish colours regardless the difference of the icon shapes. The statistical scale values were highly correlated with the colour difference between the colour of the button and their background, and the lightness of the icon colour, respectively.

**Keywords:** *input button colour, icon shape, background colour, user's pressing motivation, touch screen*

## INTRODUCTION

The user Interface design on mobile devices such as a mobile phone and a tablet PC is important from the aspect of usability for visual communication. Input buttons are an essential element to operate touch screen devices. They need to be pressed by users. There are various colours and icon designs for input buttons. Colours and icon designs could affect usability and it could be related to user preference, visual attraction and pressing behaviour.

In our previous studies (Nishiyama et al. 2013, Mizutani et al. 2016, 2017), the series of experiments were conducted. The colour influence on user's motivation to press an input button, visual attraction of a coloured input button, and colour preference were discussed based on the results of the visual experiments. It was found that the buttons with yellowish, orangish and reddish colours were frequently pressed. It was also found that the user's pressing motivation was similar to visual attraction and visibility. The aim of this study is to understand the influence of background

colours of buttons on user's pressing motivation on touch screen device, through the similar experiments of our previous studies. This study was also carried out to understand the influence of an icon button design on the user's pressing motivation. In this study, two visual evaluation experiments, Experiment I and II, were conducted using a mobile phone. Experiment I was to know the influence of a background colour. Experiment II was to know the influence of an icon button design focusing on shape and colour.

## EXPERIMENTS

The experiments were conducted using the same method and instruments as our previous studies. A mobile phone iPhone 6 (Apple Inc.) was used. The size of the phone was 67.0 × 138.1 mm, and the resolution of the screen was 1334 × 750 pixel, 326 ppi. The experiments were conducted in a room under the lighting of fluorescent lights. Twenty Japanese university students (ten male and ten female students, aged from twenty to twenty-five years old) participated in the experiments. The colour vision of the subjects was tested by the Ishihara test with subjects' agreement and under the rule of the Ethics Committee in Kyoto Institute of Technology. All the subjects had no colour vision deficiencies. A paired comparison method was applied. As shown in Figure 1, two input buttons with different colours were presented on the screen of the mobile phone. The subjects were then asked to press one of the buttons intuitively of which gave higher motivation to press. Figure 2 shows the colours used for the buttons and background colours in the Experiment I. There were twelve button colours consisting of four hues: Red (R), Yellow (Y), Green (G) and Blue (B). Each hue had two colour tones: light (lt), vivid (v), and four neutral colours (N) based on the PCCS (Practical Colour Co-ordinate System). The shape of the button was circle. Figure 3 shows the shapes and colours used for the icon buttons in the Experiment II. The eight icon shapes were circle, square, cross mark, thumbs up, star, water drop, heart and clover. The colours are the same to the Experiment I. The background colour of the icon buttons was middle grey (N5). The numbers of the colours used for the buttons in the both of the Experiment I and II was less than the previous studies. The coloured buttons were presented to the subjects in random order. In our system, the results of both Experiment I and II were automatically recorded in the spreadsheet of online storage as well as the previous studies.

The colorimetric values of these colours were measured using a spectroradiometer CS-1000 (Konica Minolta Inc.). The CIELAB values of all the button and background colours were calculated.

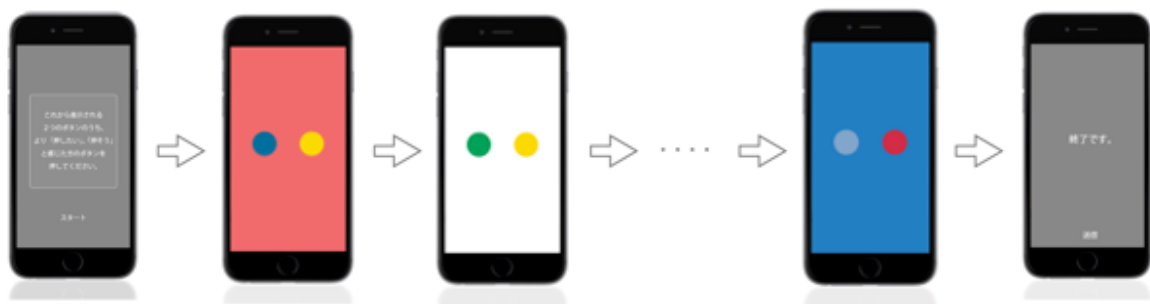

Figure 1: The example of the experimental procedure.

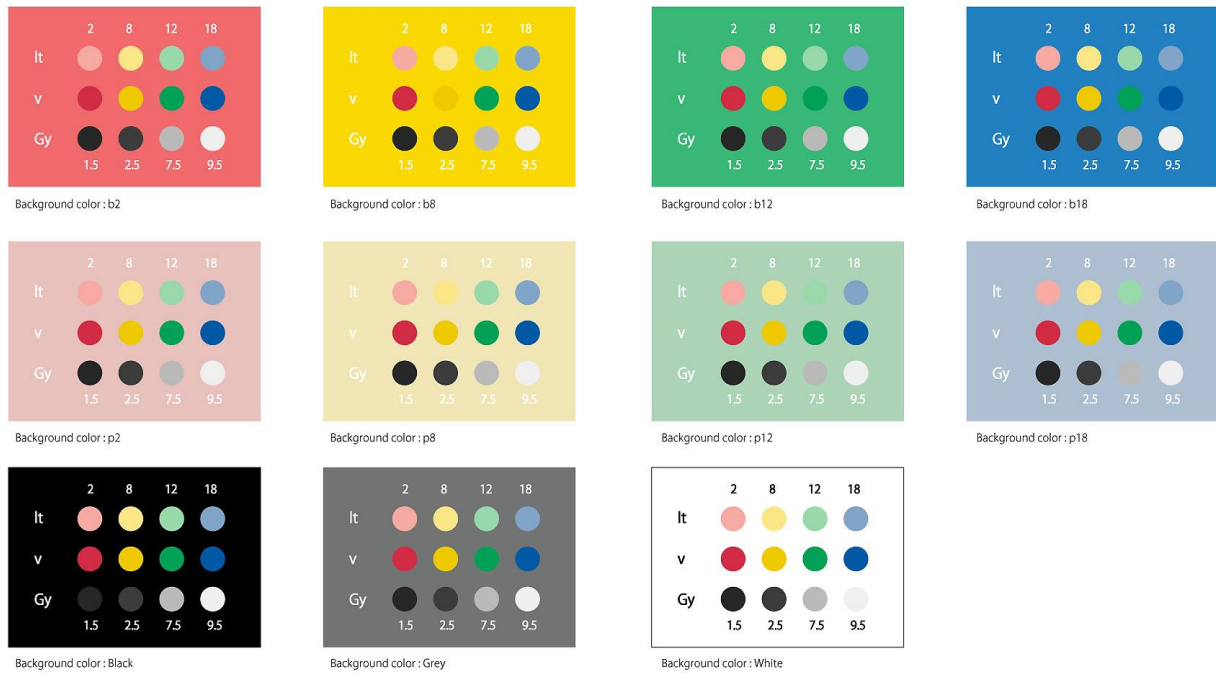

Figure 2: The colours of button and background used in the Experiment I.

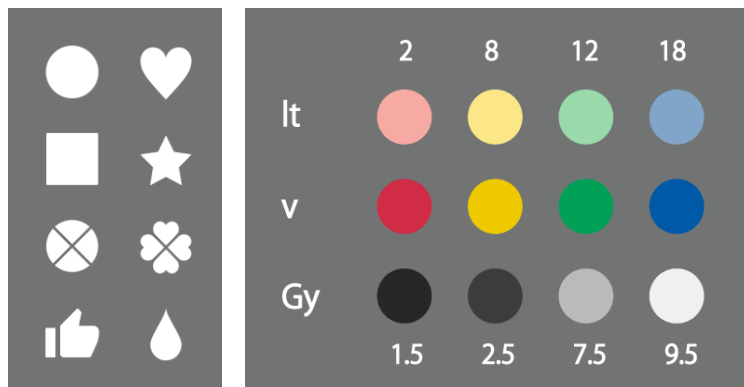

Figure 3: Icon button shapes designed for the Experiment II and their colours.

## RESULTS

Frequency of the pressed button was defined as the level of pressing motivation. The most frequently pressed button can be considered as the colour which gave a highest motivation to press to the subjects. In addition, the scale values each button (icon) colours for the Experiment I and II were calculated. The results of the Experiment I was summarized in Figure 4. It shows the order of buttons' colours accordingly to their scale values of the pressing motivation and the scale values for the 11 different background colour conditions. The right side colours or larger values indicate the more frequently pressed colours in Figure 4. The colours of which were the most pressed button was red for the pale background colour condition, however for the deep background colour condition, yellow

was tended to be pressed more often than red. The results of the Experiment II were summarized in Figure 5. It shows the order of buttons' colours accordingly to their scale values of the pressing motivation and their scale values of the eight icon shapes. It indicated that the yellowish colour was often pressed regardless the shapes. The influence of icon shape was also observed, for instance the light and dark green showed relatively higher scale values for the clover icon. It considered to be the influence of the original colour of clover. However, the influence of the icon shape was very little. The blue colour was thought to give a higher scale value for the water drop shape, however it gave a quite low scale value. For the heart, red was not the highest. From these results, it was not clear that the shape did not affect to the pressing motivation.

Correlations between the colorimetric values and scale values of each button colour were analysed to investigate the relationship with the colour properties and the pressing motivation. Table 1 shows the correlation coefficient between the colorimetric values and the scale values of the pressing motivation for each background colour condition. Colour difference value  $\Delta E^*_{ab}$  between the colours of the buttons and their background colours was highly correlated with the scale values of the pressing motivation.

Similarly, Table 2 shows the correlation coefficient between the colorimetric value and the scale values of the pressing motivation for each icon shape. There was a strong correlation between the lightness ( $V, L^*$ ) of the icons and the scale values.



Figure 4: The scale values of button colours on 11 back ground colour conditions. The right side colours are the more frequently pressed colours.

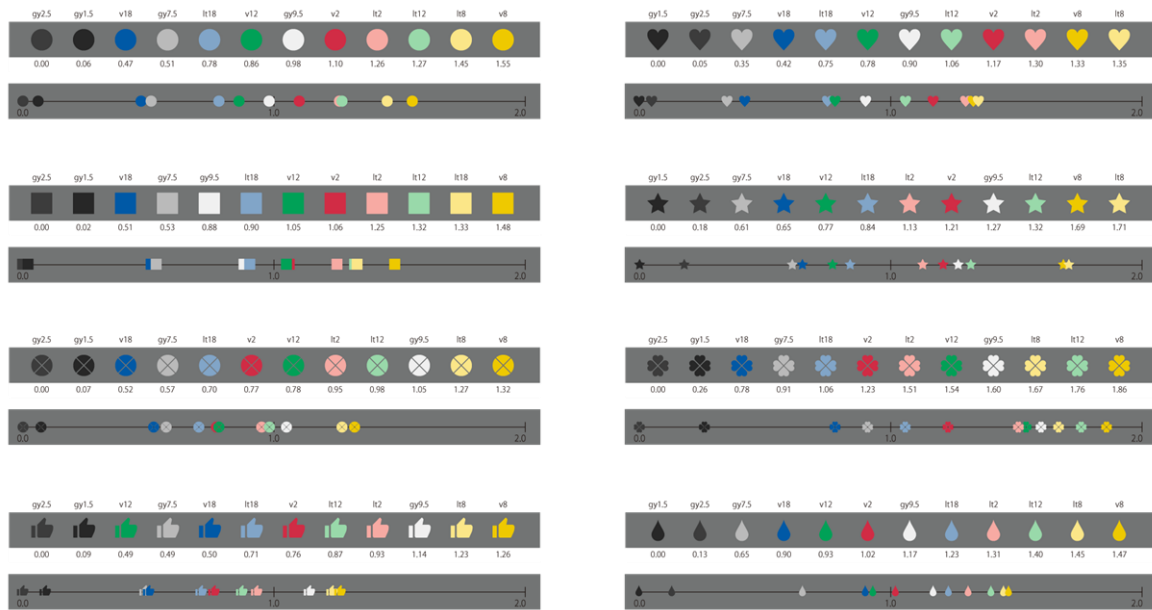

Figure 5: The scale values of button colours on 8 icon shapes. Right side colours are higher pressed colours.

	H	S	V	R	G	B	L*	a*	b*	C*	h	ΔE
W	0.60	<b>0.72</b>	-0.29	-0.51	-0.63	-0.65	-0.59	0.12	0.10	0.66	-0.01	<b>0.88</b>
Gy	-0.39	0.64	<b>0.78</b>	0.51	0.48	-0.03	0.58	0.05	0.57	<b>0.77</b>	-0.71	<b>0.84</b>
Bk	-0.15	0.64	<b>0.89</b>	0.50	0.58	0.21	<b>0.70</b>	0.04	0.40	<b>0.71</b>	-0.65	<b>0.95</b>
p-R	<b>0.78</b>	0.56	-0.12	-0.39	-0.42	-0.23	-0.38	0.14	-0.09	0.48	0.21	0.64
p-Y	0.67	0.65	-0.25	-0.52	-0.65	-0.40	-0.58	0.27	-0.17	0.50	0.11	<b>0.83</b>
p-G	0.41	0.59	-0.09	-0.22	-0.49	-0.37	-0.40	0.39	0.01	0.49	-0.08	<b>0.81</b>
p-B	0.31	<b>0.70</b>	0.01	-0.13	-0.35	-0.57	-0.28	0.21	0.33	<b>0.73</b>	-0.33	<b>0.88</b>
R	-0.03	0.64	0.33	-0.07	0.37	-0.09	0.30	-0.41	0.31	0.63	0.43	<b>0.71</b>
Y	<b>0.75</b>	0.21	-0.32	-0.56	-0.61	0.10	-0.57	0.31	-0.62	0.00	0.23	<b>0.81</b>
Gy	-0.03	0.31	0.32	0.47	-0.12	-0.26	0.04	0.67	0.28	0.41	-0.49	<b>0.72</b>
Bk	-0.28	0.19	0.49	0.65	0.28	-0.31	0.41	0.18	<b>0.77</b>	0.46	<b>-0.88</b>	<b>0.84</b>

Table 1: Correlation coefficient between colorimetric value and the scale of pressing motivation for each background colour condition.

	H	S	V	R	G	B	L*	a*	b*	C*	h	ΔE
Circle	-0.56	0.42	<b>0.90</b>	<b>0.72</b>	0.68	0.10	<b>0.79</b>	0.01	0.65	0.62	<b>-0.73</b>	0.68
Square	-0.58	0.48	<b>0.89</b>	0.63	0.68	0.12	<b>0.78</b>	-0.08	0.61	0.65	<b>0.70</b>	0.66
Cross mark	-0.68	0.39	<b>0.93</b>	<b>0.71</b>	<b>0.80</b>	0.22	<b>0.88</b>	-0.09	0.60	0.55	-0.55	0.66
Thumbs up	-0.60	0.28	<b>0.93</b>	<b>0.80</b>	<b>0.77</b>	0.27	<b>0.87</b>	0.05	0.26	0.45	-0.51	0.59
Heart	-0.48	0.42	<b>0.89</b>	<b>0.73</b>	0.59	0.10	<b>0.73</b>	0.11	0.61	0.62	<b>-0.86</b>	0.66
Star	-0.46	0.38	<b>0.91</b>	<b>0.76</b>	<b>0.70</b>	0.15	<b>0.81</b>	0.04	0.61	0.58	-0.59	0.68
Water drop	-0.66	0.42	<b>0.95</b>	0.63	<b>0.74</b>	0.35	<b>0.83</b>	-0.04	0.40	0.54	-0.33	0.54
Clover	-0.63	0.41	<b>0.89</b>	0.61	<b>0.79</b>	0.23	<b>0.85</b>	-0.20	0.57	0.55	-0.58	0.64

Table 2: Correlation coefficient between colorimetric value and the scale of pressing motivation for each icon shape.

## CONCLUSION

This study conducted the experiments in order to understand the colour influence on human practical response through pressing colour buttons on touch screen device and the relationships among the button colour, back ground colour and icon shape.

The results suggested the large influence of the colour on user's motivation to press input buttons. The colour which had the highest scale value was red and yellowish colours. These results agree with the previous studies. The icon shapes did have a large influence on the pressing motivation.

Correlations between colorimetric values and the scale values of the colours were also analysed. The scale values of the circle button were highly correlated with colour difference ( $\Delta E^*ab$ ) values between the colours of the buttons and their background. The results of the various icon shapes suggested that the scale values were correlated well with lightness (V and L\*).

## REFERENCES

- Mizutani, Y., S. Kitaguchi, and T. Sato. 2016. Colour influence on user's motivation to press input button —Analysis using paired comparison. In: *AIC 2016 Interim Meeting "Color in Urban Life: Images, Objects and Spaces", Book of Proceedings*, Santiago de Chile, 18-22 October 2016, I. Calvo Ivanovic, ed. Santiago de Chile: Asociación Chilena del Color, 177-180.
- . 2017. Colour influence of input button on user's pressing motivation, visual attraction, and preference —Analysis using paired comparison. In: *AIC 2017, 13th Congress of the International Colour Association, "Being Color With Health", Proceedings*, Jeju, Korea, 16-20 October 2017. Seoul: Korean Society of Color Studies, OS05-08, 4 pages.
- Nishiyama, D., H. Jung, S. Kitaguchi, and T. Sato. 2013. Colour influence on user's motivation to press an input button. In: *AIC Colour 2013, 12th Congress of the International Colour Association, Proceedings*, Newcastle upon Tyne, UK, 8-12 July 2013, L. MacDonald, S. Westland, and S. Wuerger, eds., 4 vols. London: The Colour Group of Great Britain, 1217-1220.

# Memory effects for metallic colored objects in different memory periods

Paru Kondo, Midori Tanaka\*, Takahiko Horiuchi

Chiba University, Japan

\* midori@chiba-u.jp

## ABSTRACT

A memorized color can differ from the original color. However, it has not been deeply investigated whether this observation exists for metallic colors. This study considers how the memory effect for metallic colors changes under different memory conditions by conducting psychometric experiments. In the experiments, we prepared three kinds of copper-colored real materials with the different glossy surface but the same color and 3D shape. Then we conducted two experiments under different memory periods. Different memory results were obtained depending on the samples with different glossy surfaces. Moreover, the effect also changed according to the difference in the memory period. In addition, we found that the saturation and luminance contrast of the memorized metallic color reduced during the three-day period.

**Keywords:** *memory effect, metallic color, memory period*

## INTRODUCTION

It is widely known that a memorized color can differ from the original color. However, it has not been deeply investigated whether this observation exists for metallic colors. In our previous study, we revealed that brightness contrast, in addition to chroma, was emphasized in our memory paradigm using gold materials (Horiuchi et al. 2016). Furthermore, in our earlier experiment, we found that the memory effect varied based on the metallic color (Kondo et al. 2017). In this study, we experimentally consider how the memory effect for metallic colors changes under different memory conditions by conducting psychometric experiments. To conduct the psychometric experiments for achieving the purpose, we prepare three kinds of real materials with the different glossy surface but the same color and shape.



## EXPERIMENTS

In our previous study, we found that even if the reproduction image had physically the same color as that of the original object based on colorimetric reproduction, observers judged they were not equivalent in their side-by-side comparison. This may be caused by the problem of observer metamerism. Therefore, before the memory matching experiments (Experiments A & B), as a preliminary experiment, we conducted side-by-side comparisons between the original objects and their rendered images and determined perceptually equivalent color images for each observer as an origin. After the preliminary experiment, we conduct the memory matching experiments in different memory periods —just after memorizing, after three days— to look into the memory effect for a metallic colored object. For these experiments, to investigate the memory effect for metallic colors, we used the following three types of copper-colored objects, as shown in Figure 1.

- Sample #1: a metallic colored object with metallic glossiness.
- Sample #2: a matte object with the same shape and color as sample #1.
- Sample #3: a matte object with the same shape and color as sample #1 with painted glossiness using a highlight color.



Figure 1: Copper colored objects of experimental stimuli.

### Preliminary experiment

According to our previous study, it was confirmed that colorimetric color reproduction was not necessarily equivalent even if side-by-side observation of a real object and a reproduced image. Therefore, to investigate perceptually equivalent reproduced images for metallic colors in each observer, a matching experiment of the real object and reproduced images was conducted.

First, a colorimetric color reproduction image was prepared as an image stimulus. Then, the luminance contrast (CNT) and saturation (SAT) of the reproduced image were modulated in three steps, and 15 images were generated for each sample by combining the modulation. In the preliminary experiment, as shown in Figure 2, 16 image stimuli were arranged in order was prepared and used for the experiment. The observer selected one image as an origin most similar to the sample by comparing the actual sample with the 16 images presented on display.

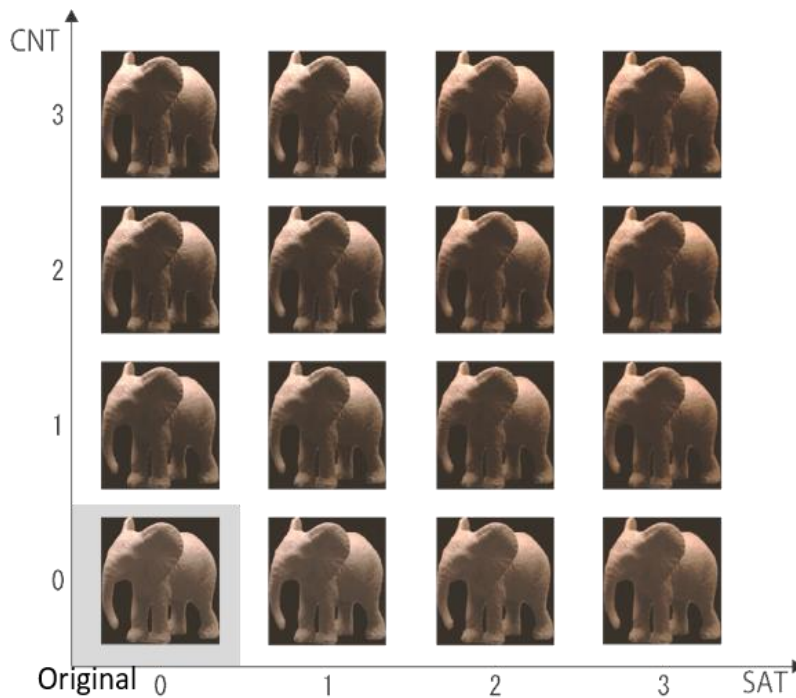

Figure 2: Experimental image stimulus with modulated saturation and luminance contrast.

### Experiment A

The observer gazed at the object for 20 seconds and memorized it. Immediately after memorizing, the object was hidden, and an image with a perceptually equivalent appearance to the memorized scene was selected from among fifteen displayed images in which the saturation and luminance contrast were changed.

### Experiment B

The observer gazed at the object for an unlimited amount of time and memorized it. After three days, an image with perceptually equivalent appearance to the memorized scene was selected from among the same fifteen displayed images as in Exp. A.

## RESULTS AND DISCUSSION

Ten observers participated in our experiments. The experimental results of memory matching in Exp. A showed that both saturation and luminance contrast were enhanced, which was also observed in our previous study. Figure 3 shows the answered result shift between Experiments A to B. The vertical, horizontal axes, and circle size show the luminance contrast, saturation, and the number of observers, respectively. For example, circles in the third quadrant mean the observers who have memory effect with decreased both characteristics CNT and SAT. In more detail, the results for samples #1 and #3 in Exp. A, and the results for samples #2 and #3 in Exp. B had the same tendency. On the other hand, we found that the saturation and luminance contrast of the memorized metallic color reduced during the three-day period.

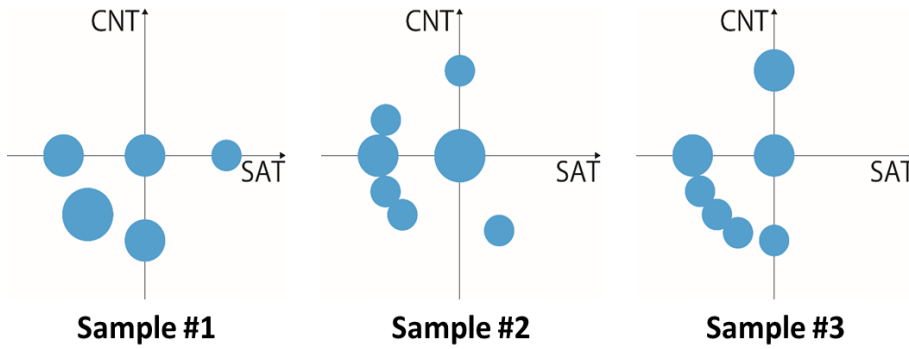

Figure 3: Shift of answered result in memory matching from Experiment A to Experiment B.

A conventional study reported that the memorized color shifts to the focal color of its color category (Miyake et al. 2015). To investigate the relationship between the cause of decreased luminance contrast and saturation after three days, we focused on the relationship between the color category and focal color for each observer. For each sample, the observers selected an appropriate color term from among the nine category colors (red, orange, yellow, green, blue, purple, brown, pink, grey). As a result, most observers selected the color category “brown” for each sample, and they were looking at the head and back part of the sample during observation. The selected focal color and shifted results are shown in Figure 4 (a, b). However, our result indicated that the color category was irrelevant to the focal color.

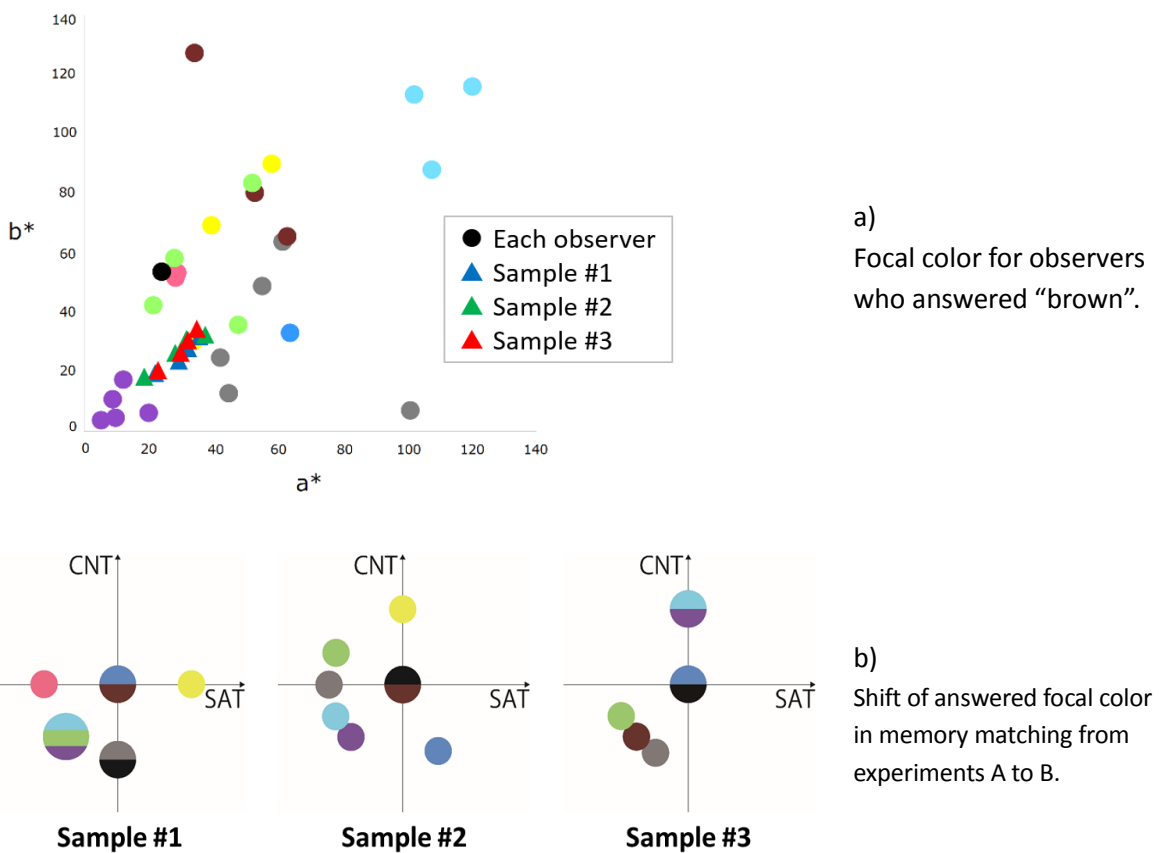

Figure 4: Result for focal color investigation.

## CONCLUSION

In this study, we experimentally consider how the memory effect for metallic colors changes under different memory conditions by conducting psychometric experiments. Different memory results were obtained depending on the samples with different glossy surfaces. Moreover, the effect also changed according to the difference in the memory period. In addition, we found that the saturation and luminance contrast of the memorized metallic color reduced during the three-day period.

## ACKNOWLEDGEMENTS

This work was supported by JSPS KAKENHI Grant Number JP15H05926 (Grant-in-Aid for Scientific Research on Innovative Areas “Innovative SHITSUKAN Science and Technology”).

## REFERENCES

- Horiuchi, T., Q. Zheng, and K. Hirai. 2016. Memory effects in gold material perception. In: *Proceedings of the 4th CIE Expert Symposium on Colour and Visual Appearance*, 381-386.
- Kondo, P., M. Tanaka, and T. Horiuchi. 2017. A memory effect in metallic material perception. In: *AIC 2017, 13th Congress of the International Colour Association, “Being Color With Health”, Proceedings*, Jeju, Korea, 16-20 October 2017. Seoul: Korean Society of Color Studies, PS03-56.
- Miyake, H., A. Osa, and T. Kinoshita. 2015. Basic research for utilizing color memory in color design. *Journal of the Science of Design*, 62 (4): 51-60 (in Japanese).

# Research on the influence of children's building block color on children's learning process

Ruolin Gao\*, Haiwei Yan

Beijing Institute of Technology, China

\* azure\_echo@163.com

## ABSTRACT

Currently, STEAM education (Science, Technology, Engineering, Arts, and Mathematics) is becoming more and more popular in various countries around the world, and the emphasis on early childhood education increases dramatically every day. As a kind of teaching aid commonly used in STEAM education, building blocks are well-known in terms of spatial cognition and logical education.

**Objectives:** To study the influence of color on children's building blocks and achievements, and to explore a reasonable color scheme for children's building blocks.

**Methods:** This study designed a comparative experiment of monochromatic and color blocks, and randomly selected a group of 3-5 year old preschool children for observation. By observing the children building blocks, documenting the results of this task and the time employed, we analyze the impact of color on children's logical thinking and cognitive abilities.

**Results:** Through experiments and analysis, it can be found that color has a significant influence on the shape and structure of objects built with blocks by children, and the logical sequence that they follow. Colored blocks help children understand the structure and build it.

**Keywords:** *building bricks, children education, color scheme, cognition*

## INTRODUCTION

With the development of research and technology, the education of young children continues to improve. Studies have shown that young children are considered to be at a critical stage in the creative development (Eliot 1999, Goswami 2004, McCain et al. 2007). Therefore, the enlightening education of preschool children has attracted more and more attention from researchers.

Many scholars have studied the effects of building blocks on children's cognition. Most of the researchers' studies show that tasks with blocks are important for cognitive processes such as early childhood spatial cognition.

Beth et al. (2008) pointed out that teaching block building develops wider spatial skills. Xiaoxia Zhang (2013) studied the construction level of 4-5 years old children's building blocks and their

influence on the development of geometric space ability. The research results show that the development of children's geometric space ability can be promoted by building blocks.

At the same time that innovative educational methods have been widely promoted, a series of building blocks such as Lego have gradually become one of the most important teaching aids. These types of teaching aids are highly flexible for teaching. However, current research on the color of building blocks is lacking, and the color schemes on the market are mixed. This article will focus on the impact of color on building blocks in children's use.

## EXPERIMENTS

The research is mainly conducted by a comparative experiment and observation method, recording and analyzing the process and outcomes of a group of children and their completion efficiency.

We randomly selected a group of 3-5 year old children as observation subjects, informed their parents about the content and purpose of the experiment and obtained consent. Five of them received an early course on Lego bricks.

This experiment selected a basic form of "house" as the goal of this construction. The shape and colors of the house are shown in Figure 1.

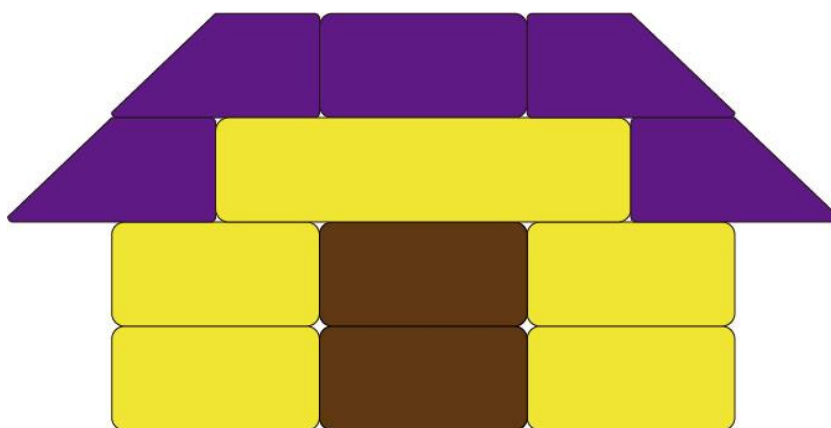

Figure 1: Example house.

The construction of this form involves the basic techniques of tiling, heightening, and overhead of the building blocks. The colors are yellow, purple and brown, and the roof, wall and door are respectively distinguished by these three colors. There are three types of building blocks required to build this "house".

Each child will complete two tasks:

Task 1: After the children have been shown the assembled house, ask the children to build and use the colors they want. Record the process of building and record the time employed.

Task 2: After the children have shown the assembled house, ask the children to use only the white blocks. Record the process of building blocks and record the time spent.

## RESULTS

The time taken to build blocks is shown in Table 1.

Children	Time	
	Color blocks	White blocks
A	69	86
B	112	81
C	106	109
D	109	172
E	166	118
F	83	100

Table 1: The time taken to build blocks.

Due to the small sample size, the results are not statistically significant, but they still reflect certain problems. Among the 6 children who completed the task, 4 of them showed that the time spent assembling the colored blocks was less than the time taken to put together the white blocks. We conducted a more detailed analysis and interviews with two children who used a shorter period of time to build the house with white bricks. The reason was that with the colored blocks, they spent a lot of time to pick their favorite colors and redesign the house.

We also recorded and analyzed their ways of building with blocks. The children's understanding of the shape and structure of the samples was analyzed from the process and the results. The process of building blocks for children is summarized in Figures 2, 3 and 4.

**Child A:** From the perspective of the structure, the subject A first divided the "house" into 2 parts, the trapezoidal roof part and the rectangular wall part. And they were separately assembled and finally put together. In addition, A can recognize that the wall is composed of 3 identically shaped parts and is aware of the structure of the "door".

From the perspective of the logical sequence of the process of building blocks, when assembling a color house, A first completes the middle structure, and then adds the building blocks according to the principle of symmetry. When assembling a white house, A built up the house following the order from left to right (Figure 2, left). A's color house is less time-consuming than a white house.

**Child B:** From the perspective of the structure, the subject B divides the house into a roof portion composed of 4 trapezoidal bricks and a rectangular brick, and a wall portion composed of 6 rectangular bricks and a long rectangular brick. B can recognize that the wall is composed of 3 identically shaped parts and is aware of the structure of the "door".

From the logical sequence of the process of building blocks, when assembling a color house, B first completes the structure on both sides of the wall, and then installs the part of the middle "door". When assembling a white house, B installs three structures of the wall part following the order from left to right (Figure 2, right). B's color house is time-consuming and slower than the white house.

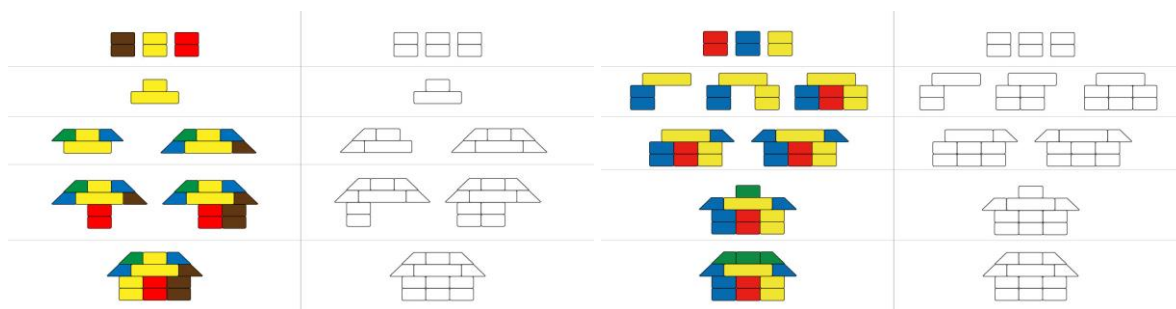

Figure 2: Process and results of building blocks for children A and B.

**Child C:** From the perspective of the structure, the subject C divided the house into a roof part consisting of 4 trapezoidal bricks and a rectangular building block, and a wall part composed of 6 rectangular bricks and a long rectangular building block. C can recognize that the wall is composed of three identically shaped parts and is aware of the structure of the “door”.

From the perspective of a logical process of assembling, C first builds the structure on both sides of the wall, and then installs the middle part of the “door”. When assembling the roof of a colored house, C first installs the middle part, then arranges the trapezoidal building blocks in a logically sequential order from left to right. When assembling the roof of the white house, C installs the structure of both sides of the roof by following the order from bottom to top (Figure 3, left). Assembling the color house used less time than the white house.

**Child D:** From the perspective of the structure, the subject D divided the house into a roof portion composed of 4 trapezoidal blocks and a rectangular block, and a wall portion composed of 6 rectangular blocks and a long rectangular block. D can recognize that the wall is composed of three identically shaped parts and is aware of the structure of the “door”.

From the perspective of a logical process of assembling, when assembling a color house, D first completes the structure of the central “door”, and then adds the building blocks according to the principle of symmetry. The roof part also adheres to the principle of symmetry. When trying to build the white house, D misunderstood the structure, finally tiling the wall part, and then following the order from bottom to top (Figure 3, right). Completing the color house uses less time than the white house.

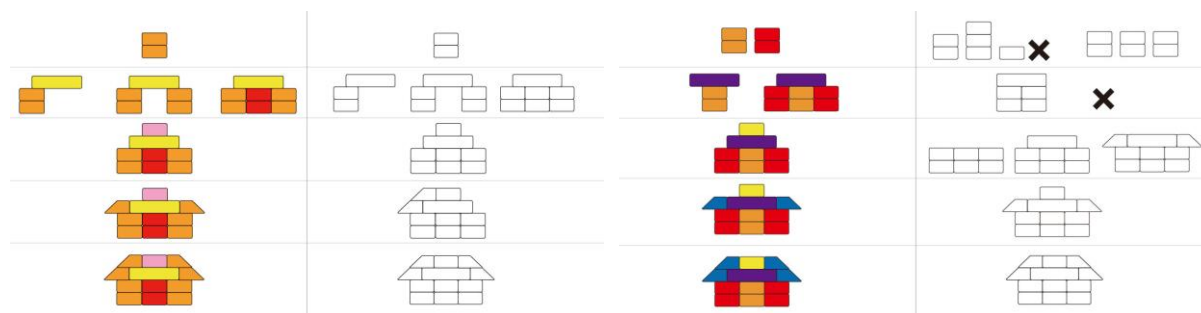

Figure 3: Process and results of building blocks for children C and D.



**Child E:** From the perspective of the structure, the subject E divided the house into a roof part consisting of 4 trapezoidal blocks and 1 rectangular building block, and a wall part consisting of 6 rectangular blocks and a long rectangular building block. E can recognize that the wall is composed of 3 identically shaped parts.

From the perspective of a logical process of assembling, when building a color house, E first completes the wall structure, then adds the roof part of the building block according to the principle of symmetry, and finally adds the most middle roof part. In the case of a white house, E first finish the wall structure and then builds the roof in a logical sequence from left to right (Figure 4, left). E's color house takes longer than the white house.

**Child F:** From the perspective of the structure, the subject F divided the house into a roof portion composed of 4 trapezoidal blocks and a rectangular block, and a wall portion composed of 6 rectangular blocks and a long rectangular block. F can recognize that the wall is made up of three identically shaped parts and is aware of the structure of the "door".

From the perspective of the logical process of assembling, when assembling a color house, F first complete the wall structure, then adds the middle part of the roof, and finally adds the building blocks of the roof part according to the principle of symmetry. When assembling the white house, the logic of F is more chaotic, and it is not arranged according to the structure (Figure 4, right). The color house of F spends less time than the white house.

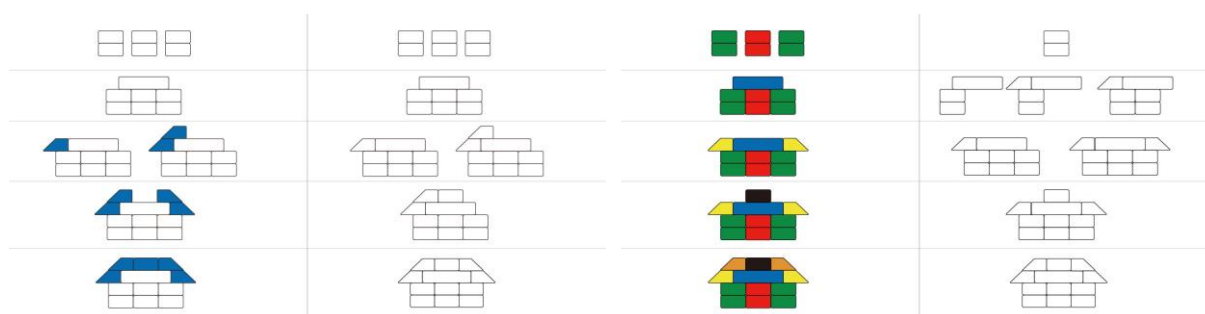

Figure 4: Process and results of building blocks for children E and F.

## CONCLUSION

Through observation and communication, we can discover the following problems in the process of children's observation, understanding and assembly:

1. From the process of assembling, we can find that children's awareness of "structure" is stronger when they assemble color houses. In the case of a color house, all children divide the rectangular wall and the door part consisting of six identical blocks into three parts, each of which is made up of two blocks of the same color. It means that during the observation of the example house before the experiment, they successfully understood the structure of the sample. This can also be confirmed in experiments about the assembling of the white house, that is, when the children are building a white house, even if there is no color distinction, they will put 6 pieces of the same building block into 3 parts and combine them together.

2. Comparing the process of the color house and the white house, we can find that the children's assembling logic is obviously different, and the cognitive styles are different. In the case of the color house assembling, "symmetry" is a more obvious way of arranging the blocks. Children will separate

the most middle part and the left and right sides, and when they are assembling white houses, they will follow the order from left to right or even follow an order according to the structure.

3. In the experiment, the speed of the majority of children's assembling indicates that the color houses are assembled faster than the white houses. Through follow-up interviews, we can know that the reason why the results of the two subjects B and E are opposite to those of the other subjects is that they spend a lot of time to choose the color and think of matching the colors.

4. D made mistakes when assembling the white house, which may provide some clues that color plays a positive role in children's understanding of the structure. The assembling process also shows that the speed to solve the task is faster when color blocks are used for assembling the house, and the error can be reduced to a certain extent.

## ACKNOWLEDGEMENTS

We would like to thank the school-age children and their parents around Beijing Institute of Technology for their support of this experiment. Thanks to Haiwei Yan for his help in the experiment.

## REFERENCES

- Beth, M. C., N. Andrews, H. Schindler, J. E. Kersh, A. Samper, and J. Copley. 2008. The development of spatial skills through interventions involving block building activities. *Cognition and Instruction* 26 (3).
- Eliot, L. 1999. *What's going on in there? How the brain and mind develop in the first five years of life*. New York: Bantam Books.
- Goswami, U. 2004. Neuroscience and education: from research to practice? *British Journal of Educational Psychology* 74: 1-14.
- McCain, M., F. Mustard, and S. Shanker. 2007. *Early years study 2: Putting science into action*. Toronto, ON: Council for Early Childhood Development.
- Zhang, X. 2013. The improvement of the construction level of 4-5 years old children's building blocks and its impact on the development of geometric space capacity. Capital Normal University.

# The effect of the number of colors in teaching blocks on children's learning

Haiwei Yan\*, Ruolin Gao, Yuanbo Sun

Beijing Institute of Technology, China

\* hoiyan1992@163.com

## ABSTRACT

Background: Building blocks are common teaching aids for expanding the logical thinking and building space cognition of young children. At present, there are many kinds of building blocks, and children can choose the types of bricks and colors in the learning stage. Major manufacturers and schools have developed appropriate teaching programs to promote products while giving children a scientific enlightenment at an early age. In the existing teaching blocks, the colors are mixed and chaotic, which may have a negative impact on children's learning, thus affecting the quality of children's learning. Purpose: To explore the most suitable color scheme, to provide guidance for manufacturers to design toys, and a reasonable color scheme can help children learn. Methods: Through interviews and comparisons to complete the comparison of the efficiency of building blocks, the impact of building blocks of different colors on learning efficiency was explored. Conclusion: On the components used by children, monochromaticity has a certain influence on the spatial structure of students compared with multi-color, and the construction time and efficiency are significantly lower than multi-color. Compared with less color, when the color is too much, the child's attention is not easy to concentrate, resulting in a decrease in task completion rate. At the same time, through experiment, the color design should limit the color to 6 kinds, among which 4-5 colors have the highest efficiency, and the number of colors can have a strong auxiliary effect on children's learning and cognition.

**Keywords:** *educational color, color scheme design, color perception*

## INTRODUCTION

Nowadays, building blocks have become an important member of teaching aids. Czech educator Comenius pointed out that building blocks are best for children. It can help children focus on something and exercise their children's abilities. University of Pennsylvania urbanism professor Witold Rybczynski found that the children's building bricks mentioned appear in the practical education of Maria and R. L. Edgeworth (1798). The building blocks, called "rational toys," are

designed to teach children gravity and physics, as well as spatial relationships, to see how many different parts become a whole. The purpose of this paper is to explore whether the number of colors and colors in teaching aids will have a certain impact on children's learning, thus providing some guidance for children's toy manufacturers' toy design color schemes.

Liu Wei (2004) distinguishes the level of children's building blocks by age and divides the building blocks into seven stages according to the level of the game skills: non-construction activities, stacking, tiling and repeating, overhead, enclosing, mode, representation, construction for the game. Sufang (2007) discovered through questionnaires and observations that monochromatic structural materials are conducive to children's construction games. The study found that the sample, sample photos, physical models and physical photos were successively used as simulation reference objects for children's construction, and the children's simulated construction behavior gradually decreased. In addition, the influence of different reference objects on the level of construction of small, medium and large classes of children has gradually increased. Tian (2016) examined the effects of different situations on the building capacity of children aged 3-5 years through experiments (2016). The results showed that the children's representation game was significantly higher than the physical photos under the physical model conditions;

## EXPERIMENTS

By investigating the sales data of building blocks toys of global sales manufacturers under a certain brand, we selected the top 9 hot-selling building block toys for 3-5 years old children (see Figure 1) and conducted 9 hot-selling products. Color analysis to get the current mainstream color scheme (see Figure 2).



Figure 1: The top nine products under a certain brand.



Figure 2: Pantone color card for the best-selling building blocks.

According to the color scheme in the above-mentioned first-selling products, nine colors were selected for the subsequent color experiment. They are Pantone P1-1C, 3582C, 2443CP, 3539CP, 3545CP, 35P6C, 116XCG, 3516CP, 3527CP. The task object “small house” is color-matched by random combination, which are solid color, two colors, three colors, ..., nine colors (see Figure 3). A total of 12 children aged 3-5 years old were recruited by the experimenters. The ratio of male to female was 1:1, including 4 children aged 3 years, 4 children aged 4 years old, 4 children aged 5 years old, and children with normal visual ability. Colorless blind color and other diseases, cognitive impairment. The 3~5 years-old are then grouped according to the number of color schemes, and the efficiency, time and memory of their tasks are compared by completing specific tasks.



Figure 3: Nine popular color schemes.

The experiment is divided into three parts. First, the building blocks are divided into two types: single color and mixed color. The mixed colors are two colors, three colors, four colors, ..., nine colors, and a total of 8 different color combinations. The program is tested. The first part of the color mixing experiment first showed the children to be tested the form to be assembled at the beginning of the test (see Figure 3) and then tested the two colors, three colors, ..., nine colors, and started the task for statistical task time and task completion. And other data. The second part of the experiment is a monochromatic building block. After observing the shape of the monochromatic building blocks, the splicing is started, and statistics such as task time and task completion are counted. The third part of the experiment is to restore the original form and record the completion status and data in the state of no form strength.

## RESULTS AND DISCUSSION

After testing, we found that 4 young children of 3 years old could not complete the test task. After the test experiment began, the splicing work of the building blocks could only carry out two-dimensional activities, that is, horizontal and vertical stacking, without obvious color preference habits.

When the 4~5 years old children were working on the splicing work, there was no significant difference, and the subjects could complete the test task completely. By comparing the task completion time of the measured users in Table1 with different color combinations, we can conclude that when the color exceeds 6 colors, the user will not use the bricks to piece together the specific shape. When completing a single individual, the number of colors is not suitable. More than 6 kinds. At the same time, when the color types are 4-5, the efficiency of the task being tested is higher than that of other color combinations.

Kid	Single color	2 color	3 color	4 color	5 color	6 color
1	86 s	—	—	69 s	—	—
2	81 s	—	—	112 s	—	—
3	109 s	—	—	—	106 s	—
4	172 s	—	—	—	109 s	—
5	118 s	166 s	—	—	—	—
6	100 s	—	—	—	—	83 s

Table 1: Six children's task completion time comparison.

At the same time, when the experiment is being tested, the test tends to assign color to the concept of "three-dimensional", that is, to construct a task object by color, such as the bottom column on both sides of the house, and the middle door, which are all the same color. Blocks are pieced together; compared to monochrome objects, they will take longer to complete and are stitched from left to right logic, without the overall concept. It can be concluded that the children will help them build the form through color (Figure 4).

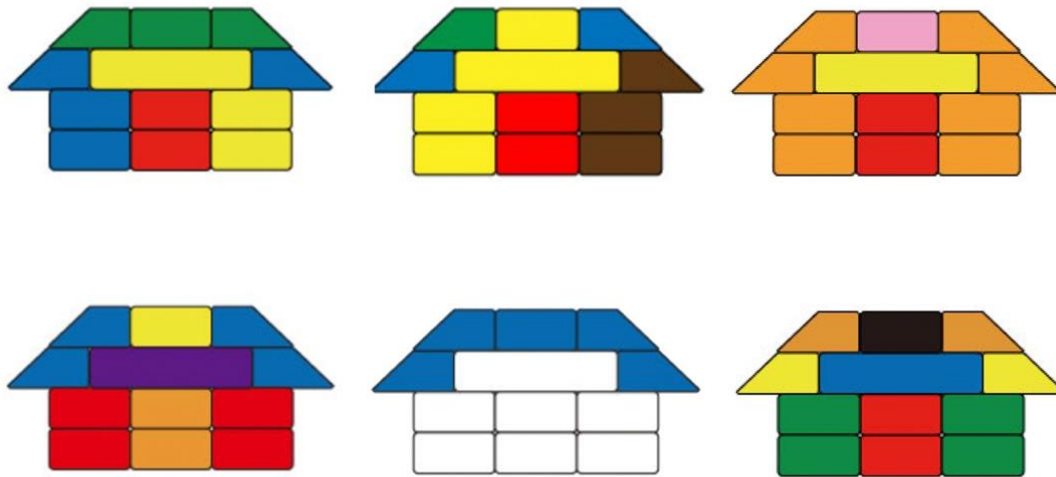

Figure 4: Example of final assembly results.

## CONCLUSION

Through testing, we can conclude that the 3-year-old child has certain difficulties in constructing a specific form of object, and is still in the development stage, suitable for open-ended thinking logic education. In the case of children aged 4-5, the type of color will affect their construction of the shape, and the color of single-volume wood products should not exceed six. At the same time, monochrome objects are not conducive to children's learning of building specific shapes. When 4-5 colors are used, they are the most efficient for object construction. At the same time, with the increase of age, children will build the concept of "whole". By using colored building blocks to teach, it can effectively help children to build a "holistic" way of thinking.

## ACKNOWLEDGEMENTS

We would like to thank the school-age children and their parents around Beijing Institute of Technology for their support of this experiment. We would like to thank Mr. Huang, an associate professor at the School of Optoelectronics, Beijing Institute of Technology, for her information support. Thanks to Ruolin Gao for her help in the experiment.

## REFERENCES

- Sufang, D. 2007. *The study of the influence of structured game material placement on children's structural game behavior*. Shanghai: East China Normal University, master thesis.
- Tian, M. 2016. *The development of structural representation of children aged 3-6 years. An experimental study based on building blocks*. Nanjing: Nanjing Normal University, master degree.
- Wei, L. 2004. *General discussion of children's games*. Beijing: Beijing Normal University Press.

# How could the colour “blue” become a “cool/cold” colour?

**Kazim Hilmi Or**

Private Office of Ophthalmology, Nisantasi, Istanbul, Turkey  
hilmi.or@gmail.com

## **ABSTRACT**

Blue is perceived as a cool/cold colour, which does not reflect the physical properties defined in colour temperature. Interdisciplinary knowledge is needed to explain this phenomenon. In the colour perception blue is considered to be a cool/cold colour. In fact colour temperature is measured for many reasons in science which can be a part of perception characteristics in illumination, human and biological vision and perception. As the wavelength of the light becomes shorter, the colour temperature becomes higher. Blue has a higher energy and is perceived in higher temperatures. The direct hot perception is with a fire. The center of the flame, which is hotter, has blue colour, which is mostly not seen by human's eyes because it is covered by the outer red part. There are many examples for this human perception in nature. So blue colour is perceived by human beings as the cooler or cold colour.

**Keywords:** *blue, cold/cool perception, discrepancy, scientific colour temperature*

## **INTRODUCTION: BLUE COLOUR IN PHYSICAL TEMPERATURE**

In physics colour temperature is measured with black bodies. Black bodies are normally ideal structures, which do not exist. In practical science hollow black bodies (spheres with 1 meter diameter or scientifically equivalent masses) are used. The surface of black bodies radiate electromagnetic waves due to the achieved temperature of the black body. According to the level of heat, the surface is perceived in different colours, which are called colour temperature (Baer et al. 2016).

According to colour temperature graphs electromagnetic waves emitted at the higher temperatures from the black body are at higher temperatures. Red colour is emitted from the surface of the black bodies at relatively lower temperatures (Figure 1).



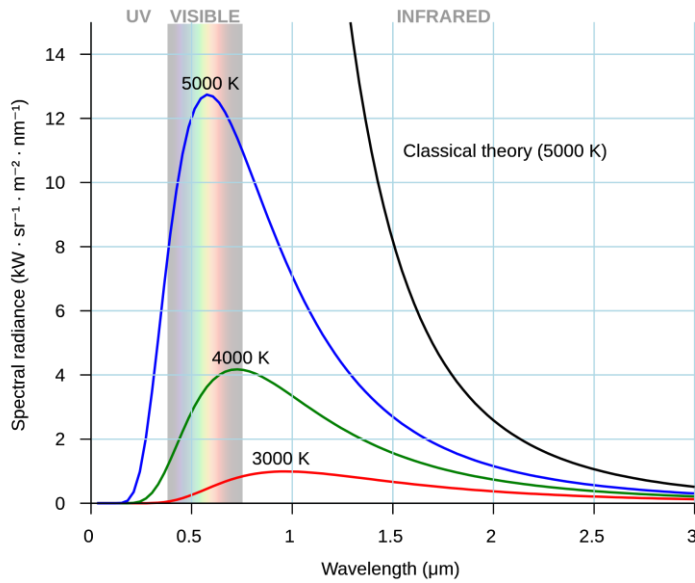

Figure 1: Black body radiation and colour temperature.  
[https://en.wikipedia.org/wiki/Black-body\\_radiation#/media/File:Black\\_body.svg](https://en.wikipedia.org/wiki/Black-body_radiation#/media/File:Black_body.svg).

**PSYCHOLOGICAL WARMTH OF COLOURS**

Psychologically red is a warm colour and blue is cool/cold colour. The colour perception of the sky and the water is blue. On the other hand fire has the colour red and is perceived as hot.

This perception is used for many decades in meteorological maps as pseudocoloured areas, which are used to show areas with the same temperature. In all these maps cold areas are shown in shades of blue and hot areas are shown in shades of red (Figure 2).

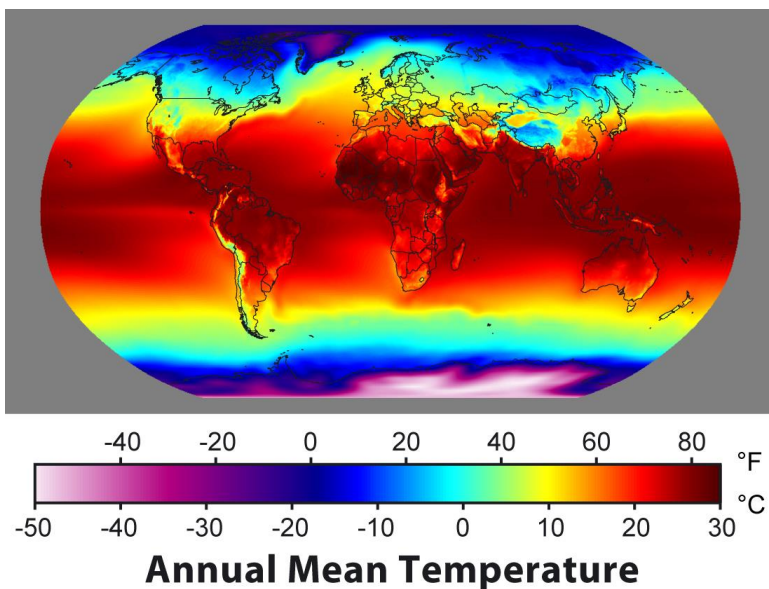

Figure 2: Annual world mean temperature map.  
[https://en.wikipedia.org/wiki/Geographical\\_zone#/media/File:Annual\\_Average\\_Temperature\\_Map.jpg](https://en.wikipedia.org/wiki/Geographical_zone#/media/File:Annual_Average_Temperature_Map.jpg).

## BLUE COLOUR IN PSYCHOLOGICAL PERCEPTION

Brain transforms the physical data to perception which are perceived through the senses. Not all the data which reaches the brain are transformed to perception. Also some non existing information may be added to the signals from the senses to form the perception by the brain. So perception may be different from physical properties. Human perception is formed and changed with the experience of individuals in their lives. For example vision/sight cannot be defined by natural sciences (it is defined by social sciences). So vision (and colour perception) is subjective. It cannot be exactly defined or explained to another person. In this way the perception of colours by humans may be also different from its physical properties (Kuehni and Schwartz 2008).

On the colour temperature scale to relatively cool temperatures (1,000 – 2,000 K) are reddish. As the temperature rises colour temperature becomes bluish. At the temperatures about 10,000 K blue is the dominant colour.

During a day the colours in the sky and at the horizon change with the daytime. From the viewpoint of temperature the relatively cooler hours around sunrise and sunset red colour is to be seen. Around the warmest hours at midday sky is bluish. So the colour temperature and physical temperature is in accordance.

The colour of fire and other hot things in daily life is mostly red or reddish. So red indicates warmth. On the other hand the “colour” of water and ice is blue, which is mostly cool. (Actually water and ice are transparent, but through the reflection of the sky on them or through the refraction in them they appear bluish.)

Because there are some discrepancies in physical properties (temperature) and their perception, blue is considered to be a cool/cold colour.

## CONCLUSION

Physical colour temperature indicates that red is emitted by relatively cool temperatures. And blue is emitted at the relatively hot temperatures. But the human perception may be different from physical properties. Because of the perception as the colour of relatively cool things in everyday life, blue is perceived as a cool/cold colour.

## REFERENCES

- Baer, R., M. Barfuss, and D. Seifert D. 2016. *Beleuchtungstechnik. Grundlagen. 4. Auflage. Deutsche Lichttechnische Gesellschaft*. Berlin: Huss Medien.
- Kuehni, R. G., and A. Schwartz. 2008. *Color ordered: a survey of color order systems from antiquity to the present*. New York: Oxford University Press.

# “Skin color” or colors of skin?

## The faces of violence in children’s drawings

**Mabel Amanda López**

Universidad de Buenos Aires, Facultad de Arquitectura, Diseño y Urbanismo,  
Programa de Investigación Color, Buenos Aires, Argentina  
ychodos@fadu.uba.ar

### **ABSTRACT**

This work is part of a broader research entitled “Rhetoric of graphic violence. Semiotic analysis of drawings by school children”, that was carried out simultaneously in Buenos Aires (Argentina) and Mexico city. Here, only results about the use of color by school children of Buenos Aires city will be presented. Within the set of analysis variables, focus is made on the use of color in the representation of faces in violent and non-violent drawings. According to the actions depicted, children identify the victims of violence with certain skin tones, while the aggressors (murderers, thieves, kidnappers, rappers) are shown with a different chromatic selection. The drawing can be a diagnostic element to know the degree of violence in which the child lives in his social environment.

**Keywords:** *skin color, drawings, childhood, violence, cultural stereotypes*

### **INTRODUCTION**

The subjects are sixth grade school children (10 to 12 years old), to whom the same questionnaire was applied and who made two drawings: one with violence and the other without violence. The corpus of drawings is analyzed qualitatively and quantitatively through narrative variables and rhetoric semiotic methods. Starting from the two main groups, violent and non-violent drawings, the results are considered in relation to the variables of gender, type of school (public or private), and the kind of violence represented (physical, with or without weapons, verbal, emotional) in order to obtain the color palettes that children select to emphasize the traits of the characters they draw.

Within the aims of the research, we proceed to identify and make an inventory of the chromatic palettes used by children to make violence and non-violence evident, according to the tones selected for the skin. The colors are analyzed in relation to objects, symbols and represented scenes, and compared to the questionnaire answered by each child. Our research questions are: What colors do they use? Is a realistic handling of color what predominates in the characters drawn, or there are disruptive or rhetoric uses which show the faces of violence in a symbolic way? Is the palette of

violent and non-violent faces similar? Are the victims represented with a different skin color than the aggressors? What social stereotypes appear?

According to our observations, the uses of black to express death, red to represent the blood of wounds, or violet for the marks of strokes, are constant in the drawings; these are chromatic signs codified by culture. However, the senses attributed to these and other colors must be recreated in the interpretative analysis of each case, and as a function of the iconography and the story told by the child, in order to reach the fullness of their meanings. It is in this framework that the color of the skin can be interpreted as a recreation of the context or as a prejudice.

## SKIN COLOR AND ITS REPRESENTATION

To interpret the results better, we contextualize the topic, reviewing conceptions about the color of skin and its representation. There is no such thing as a skin color, instead, there are many colors of skin, a set of dyes associated with the amount of melanin, a natural pigment that chemically reacts on human skin.

In the framework of evolutionary theories, Felix Von Luschan created a chromatic scale to describe the color of skin, widely used in the first half of the 20th century in anthropometric methods. The test consisted of a team of 36 glass tiles that were compared with the skin colors of a zone of the body that does not suffer sun exposure. The test lost popularity because of its inconsistencies. At the beginning of the 1950s, it was replaced by more objective methods, which used reflectance. According to Luschan, the different tones would be the result of adaptive processes to the environment. According to the geographical latitude, each community was regulating and transmitting to its descendants the amount of melanin suitable to regulate exposure to sunlight. Thus, the increase in melanin was more useful near the Equator, decreasing towards the poles, to allow greater input of solar radiation necessary for the organism (Figure 1).

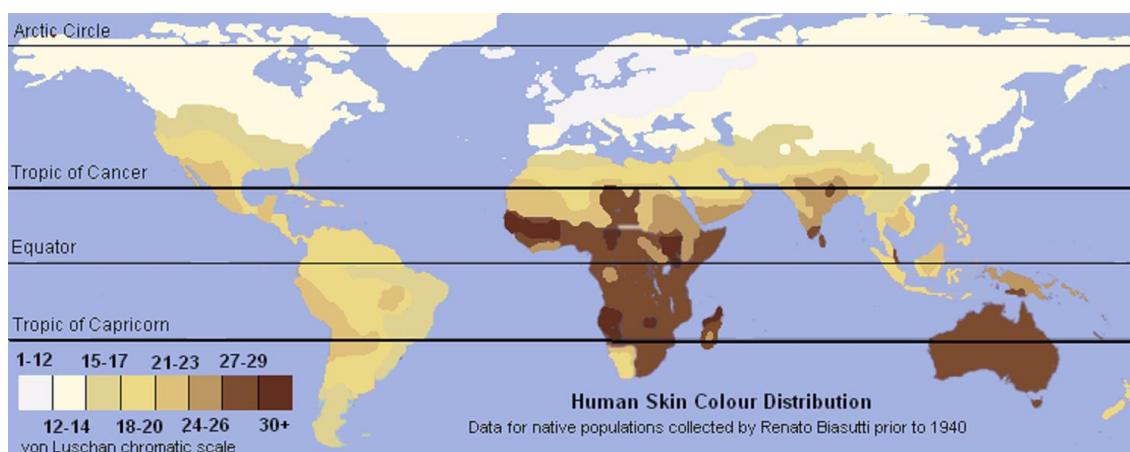

Figure 1: Distribution of the varying intensity of skin color, data for native populations collected by R. Biasutti prior to 1940.

Fitzpatrick (1975) created a scale of 6 phototypes (very clear, light, medium, Mediterranean, dark or brown, very dark or black), based on the sensitivity to ultraviolet radiation and its correspondence to sun exposure, which has been used since 1975. While Luschan tried to classify human groups according to the color of the skin in pursuit of racial discrimination, the classification in phototypes, used by doctors and cosmetologists, aims to know the dermatological characteristics of a person.

The emojis that involve skin can also be selected in 6 colors, which synthesize those of the human skin. However, in Western representation, the term "skin color" evokes a pale pink color, as it is marketed in pencils, temperas and watercolors, and that professional colorists get laboriously with delicate alchemy through mixtures. The color of the skin is very difficult to reproduce. The color of human skin is also called incarnate, which means flesh color. "The carnation, whose typical color is pale pink, is called *carnatio* in Latin, and is the Christian symbol of the Incarnation" (Heller 2004: 221). Then, the presence of a carnation in the hand of the child Jesus or an illustrious person worked as a testimony that the painting had been represented in a totally realistic way. It is interesting for our study to observe that, although there is a so-called skin color on the pencils, crayons and markers used by the surveyed children, they do not always select that color as the most appropriate for what they want to express in their drawings.

## METHODOLOGY

As a first step in the methodology to analyze the colors of skin, we select the drawings in which the study will be carried out. Of the total of 175 drawings created by children, the color of the skin of 344 represented faces will be analyzed, after discarding 44 drawings where we do not identify characters (11 violent and 33 non-violent). Having separated the drawings and identified the roles that play in the scene, the faces are cut out (Figure 2).

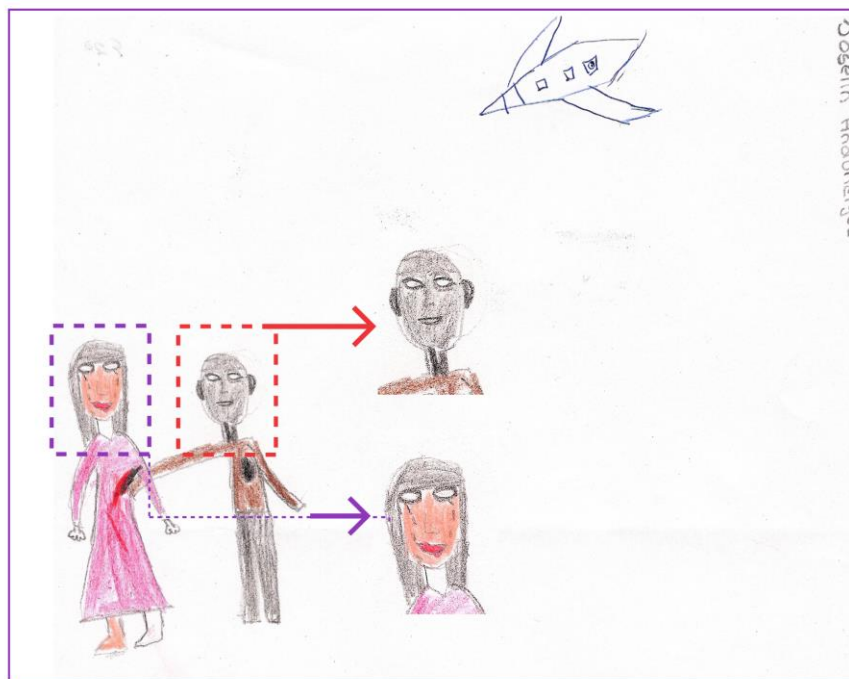

Figure 2: Interpretation of the depicted story in order to determine the roles of each character.

A representative segment is selected, where the cut box better resembles the general appearance of the color that synthesizes the eye in a global vision. Each sample is pixelated to unify the possible differences, typical of the hand drawing. Finally, it is compared with the NCS atlas to determine its notation and to label it (Figure 3).

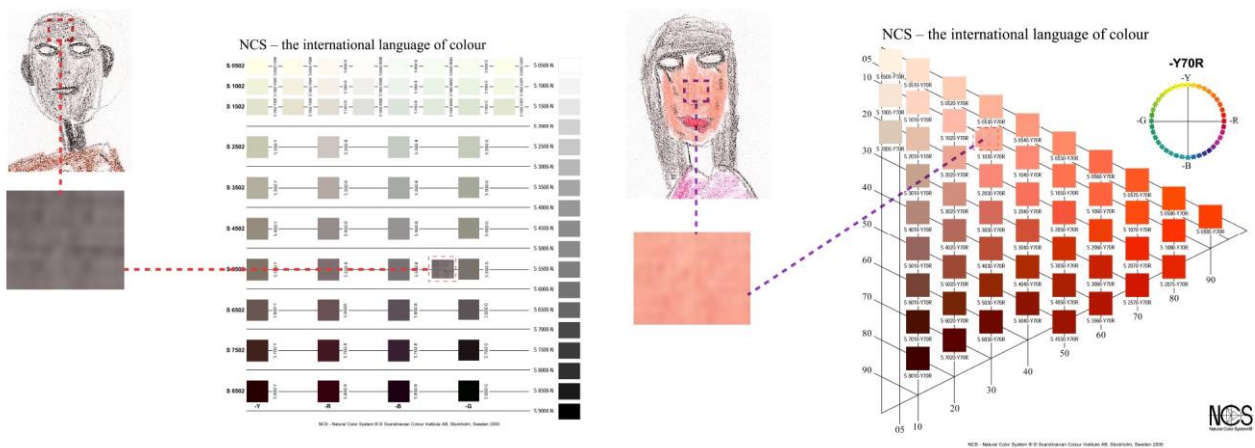

Figure 3: Method of comparison of the sample with the atlas to denominate the color notation.

### RESULTS AND DISCUSSION

Considering all the drawings, we find that most of them (75%) represent scenes with human figures, about 22% draw objects that express violence or nonviolence, while a small percentage represent parts of the body that are not the face (Figure 4, left). Violent drawings contain almost twice as many human figures as nonviolent ones (216 vs. 128). In the drawings with violence, we distinguish the roles of the subjects represented in the action, with 89 aggressors, 108 victims and 11 witnesses (Figure 4, right).

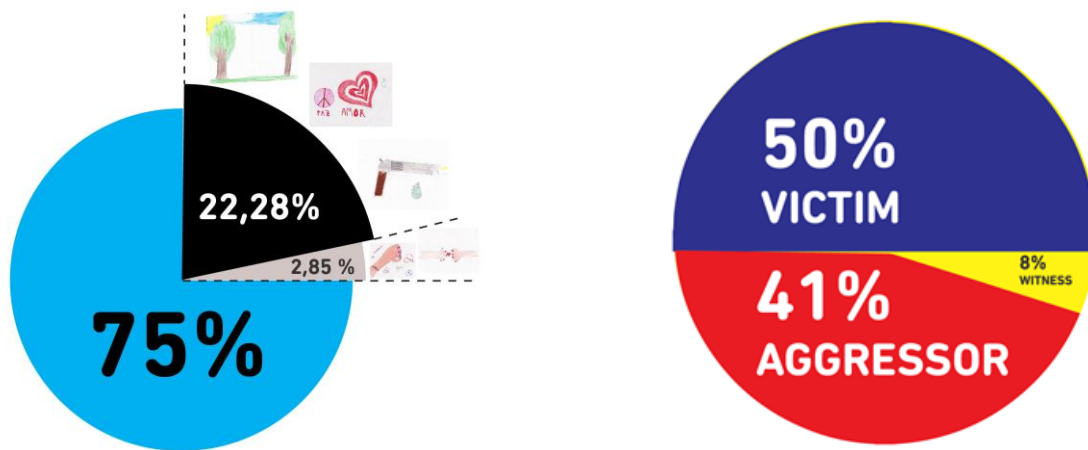

Figure 4: Percentages of drawings analyzed and discarded (left); roles in violent drawings (right).

Comparing the selected palettes for the violent and non-violent drawings, it is observed that the palettes of the most homogenous and uniform skin colors correspond to the non-violent drawings (Figure 5, left). When they are transparent, showing the white background of the paper, both characters share the same characteristics (Figure 5, right). From the pictorial tradition of the 17th century, to put color on skin had a negative connotation, even sinful. The discredit of color comes from the pigment, which associated its materiality with the body, with the libertine, while the purity of the drawing connotes the moral, by opposition, it is soul, spirit (Roque 2008).

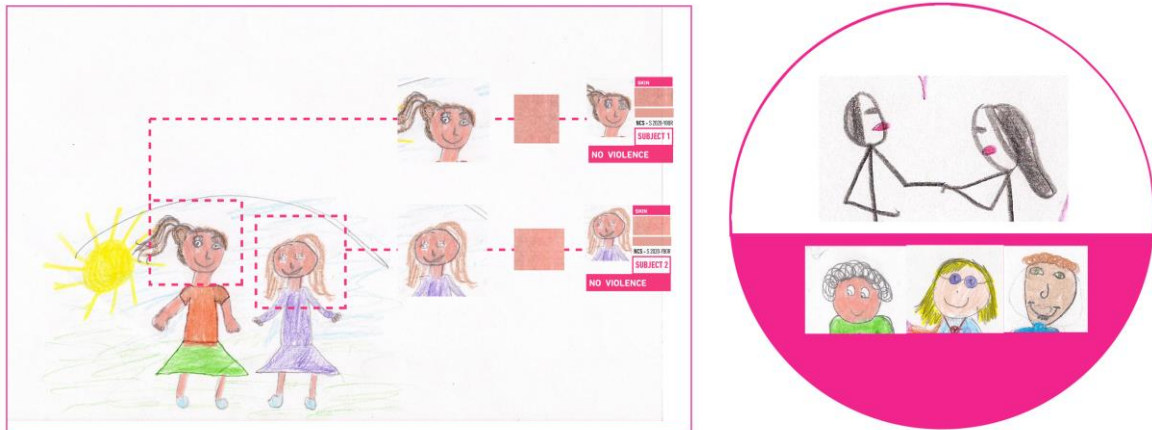

Figure 5: Nonviolent scene (left); skin colors in non-violent drawings of Buenos Aires (right).

The skin can be considered a kind of transparent sign, not marked, in the drawings of children. Pastoreau (2013: 183) explains that artists left the support bare in woodcuts, to represent flesh tones, indicating that the zero degree of color was the color of the skin. Almost 50% of faces are not colored (in violent drawings there are 103 transparent faces from a total of 216; and the same percentage remains in nonviolent drawings, with 68 transparent faces from a total of 128). In the violent drawings, both their faces and clothes tend to be more colorful than those of the victims. Not only is there a greater variety of colors, but a marked intention to differentiate the characters through skin tone, according to the roles they represent in the scene (Figure 6).

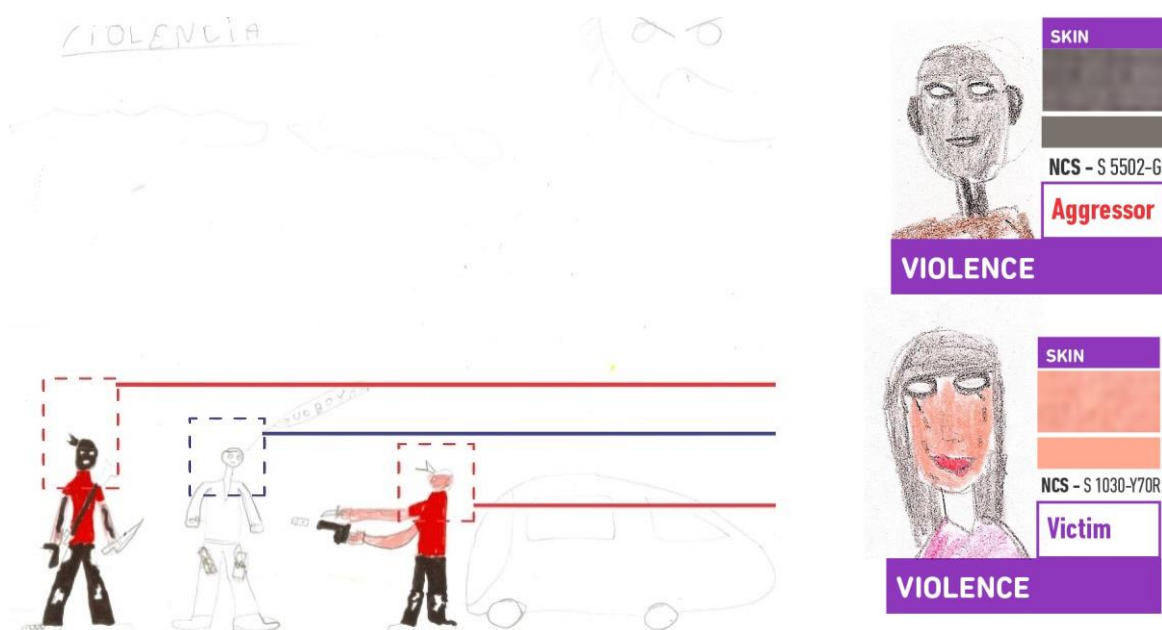

Figure 6: In the drawings with violent scenes there are differences in skin tones (left). The color of skin is one of the marks that differentiate the victims from the aggressors (right).

## CONCLUSION

The children of Buenos Aires associate violence with humans: violence has a face, exposes the skin. While nonviolence is a much more abstract and idealized concept; the heart as a symbol of love, the hands taken as friendship, the harmony of nature without the presence of man. Maybe nonviolence as an ideal is beyond human experience, that is why the scarcity of characters. We can see a solitary subject or at most a couple of friends of the same sex or in love.

In the non-violent drawings the palette of skin tones is more restricted and the characters are related, their skin color harmonizes as well as their emotionality and empathy. In contrast, in violent drawings the range of tones used is much more varied; the characters are depicted according to their roles in the action and the chromatic opposition expresses the confrontation, the violence.

The children of Buenos Aires, where there are no racial tensions, manifest prejudices in the chromatic selection of the skin. For example, it is striking that there are no victims with dark skin. However, they merely reinforce cultural meanings with regard to pink (love, tenderness, innocence), in opposition to black (death, violence, evil). These are the same ideas that children have expressed in the questionnaire, when referring to the meanings of colors (López and Ortiz 2016). These results also agree with studies of color psychology conducted in larger populations (Heller 2004, Ortiz 2011).

In the graphic expressions of children we can find the traces of a codification: figures, strokes and colors express symbolic forms with which clichés, stereotypes and prejudices about violence are reproduced in each culture.

## ACKNOWLEDGEMENTS

This research was funded by the University of Buenos Aires. I appreciate the collaboration of Belén Romero, research intern at FADU-UBA.

## REFERENCES

- Fitzpatrick, T. 1975. Soleil et peau. *Journal de Médecine Esthétique* 2: 33-34.
- Heller, E. 2004. *Psicología del color: Cómo actúan los colores sobre los sentimientos y la razón*. Barcelona: Gustavo Gili.
- López, M., and G. Ortiz. 2016. Los colores que usan los niños para expresar violencia. Estudio del caso Buenos Aires (Argentina). In: *El color y la cultura en México y el mundo*, G. Ortiz, ed. Mexico: Amexinc, 25-34.
- Ortiz, G. 2011. *El significado de los colores*, 3rd ed. Mexico: Trillas.
- Pastoureau, M. 2013. *Diccionario de los colores*. Barcelona: Paidós.
- Roque, G. 2008. El color entre carne y alma. In: *La carne y el color*. Mexico: Museo Nacional de Arte, 46-79.



# Color, Language and Culture



# Colour associations for the words *feminine* and *masculine* in nine different countries

Ivar Jung<sup>a\*</sup>, Yulia A. Griber<sup>b</sup>

<sup>a</sup> Linnaeus University, Kalmar, Sweden

<sup>b</sup> Smolensk State University, Smolensk, Russia

\* ivar.jung@lnu.se

## ABSTRACT

The main goal of this study is to examine how colours with different hue, lightness and saturation are associated with the words *feminine* and *masculine*. The objectives of our investigation were three-fold: (1) to reveal colour structure of both concepts in different cultures; (2) to visualize the obtained color associations and (3) to understand their cross-cultural similarities and differences. The experiment participants were given 26 words, including the words *feminine* and *masculine*, and asked to match each word to a sample from a chart with 27 selected colours from the NCS system. 754 subjects (470 females and 284 males) aged between 16 and 70 years (mean age 24.9) took part in the research in 9 countries. The data was collected in Germany, Iran, Japan, Nepal, Russia, Saudi Arabia, Sweden, Turkey, and Uganda. In total, the final dataset included 19,604 responses, 1,508 of which represented colour associations to the words *feminine* and *masculine*.

**Keywords:** colour associations, cross-cultural research, experiment, *feminine*, *masculine*

## INTRODUCTION

Among the leading concepts actively circulating in society, and thus being familiar to the great majority of adherents to different cultures, are *feminine* and *masculine*. Although the terms *masculine* and *feminine* have rarely been defined, they have an important empirical meaning, being used as “labels to identify specific objects, events, or qualities that in a given culture are perceived as more closely associated with males or with females” (Spence 1984). Their content reflects gender stereotypes, gender roles, actual and perceived sexual orientation and significantly differs across countries and time periods (see e.g., Paechter 2006).

The main goal of this study is to examine how colours with different hue, lightness and saturation are associated with the words *feminine* and *masculine* in different countries.

The objectives of our investigation were three-fold: (1) to reveal colour structure of both concepts in different cultures; (2) to visualize the obtained colour associations and (3) to understand their cross-cultural similarities and differences.

## EXPERIMENTS

### Design

Data were collected in the course of an experiment. The method used in this research was previously implemented during a pilot stage in Sweden and Nepal in 2016 and first presented at the AIC2016 Conference in Santiago (Jung 2016).

The experiment participants were given 26 words, including the words *feminine* and *masculine*, and asked to match each word to a sample from a chart with 27 selected colours from the NCS system. Time allocated for the experiment was not limited. Participants wrote down their responses on their own.

### Subjects

754 subjects (470 females and 284 males) aged between 16 and 70 years (mean age 24.9) took part in the experiment in 9 countries. The data in the present study was collected in Germany, Iran, Japan, Nepal, Russia, Saudi Arabia, Sweden, Turkey, and Uganda (Table 1). The subjects participated in the experiment in English. Their native languages belonged to Indo-European (German, Persian, Nepali, Russian, and Swedish), Japonic (Japanese), Afro-Asiatic (Arabic), Altaic (Turkish), and Bantu (Swahili) families.

Country	Native language	Language family	Number of subjects (F/M)	Mean age (age range)	Number of responses	Data collected by/ reference
Germany	German	Indo-European	90 (53/37)	22.1 (18-60)	2,340	Ralf Weber, Yulia A. Griber
Iran	Persian	Indo-European	60 (36/24)	20.3 (17-38)	1,560	Shabnam Arbab
Japan	Japanese	Japonic	140 (112/28)	22.4 (16-67)	3,640	Kohji Yoshimura
Nepal	Nepali	Indo-European	77 (25/52)	26.7 (18-58)	2,002	Sujan Chitrakar, Ivar Jung
Russia	Russian	Indo-European	70 (51/19)	25.1 (16-60)	1,820	Yulia A. Griber
Saudi Arabia	Arabic	Afro-Asiatic	67 (38/29)	32.0 (19-70)	1,742	Ibrahim M. Elhady
Sweden	Swedish	Indo-European	70 (54/16)	27.1 (20-56)	1,820	Ivar Jung
Turkey	Turkish	Altaic	114 (68/46)	23.7 (18-42)	2,964	Begüm Ulusoy
Uganda	Swahili	Bantu	66 (33/33)	24.8 (17-44)	1,716	Jeannette Hanenburg
Total			754 (470/284)	24.9 (16-70)	19,604	

Table 1: Characteristics of the total respondents' sample and subsamples.

The sampling was random. All subjects were recruited volunteers. They had different dialectal, educational and social backgrounds. They did not have any known colour vision defects, and they were born and lived in the same country.

The number of participants from each country, their mean age and age range, as well as the number of received responses are presented in Table 1.

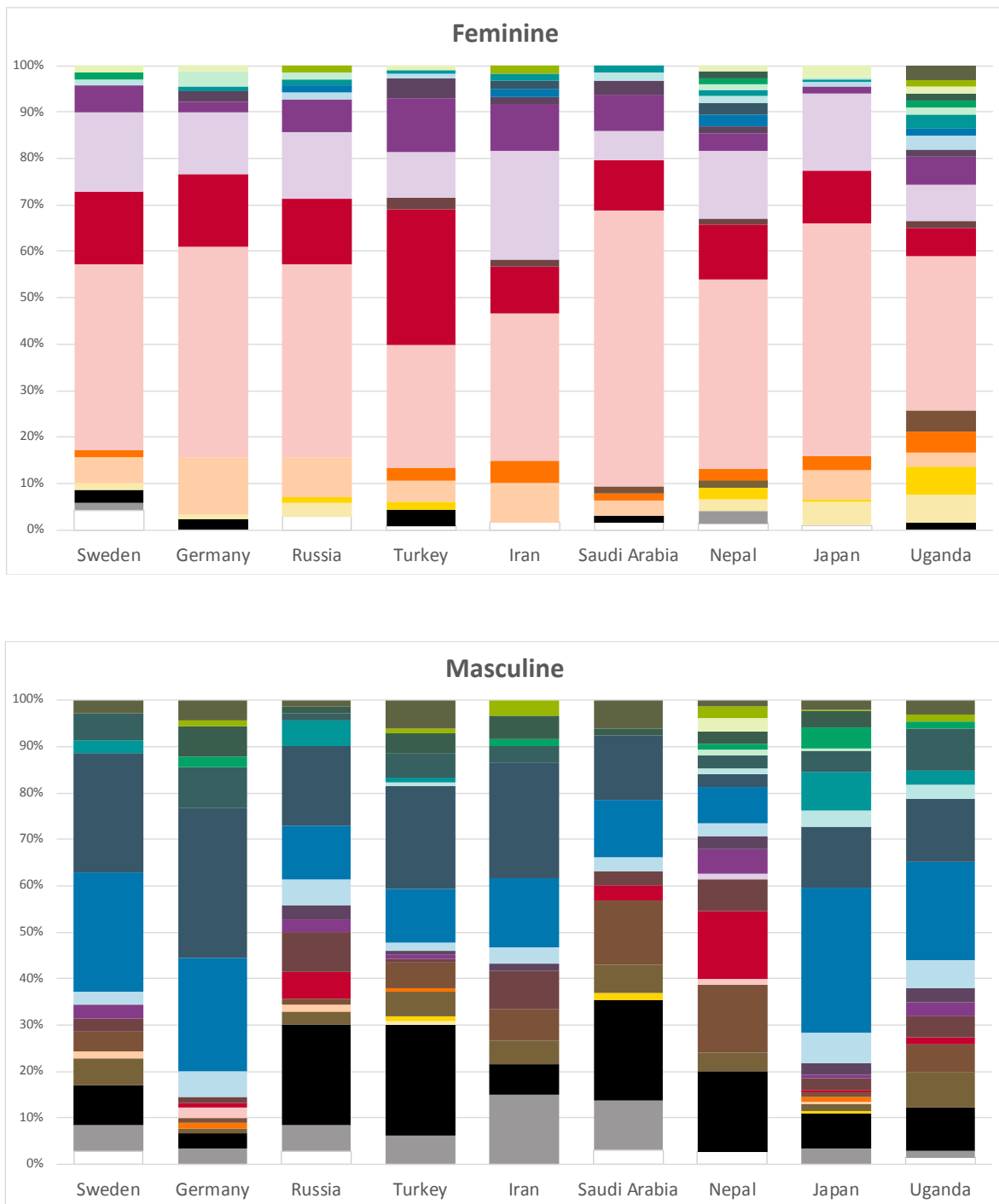

Figure 1: Colour associations to the words *feminine* (top) and *masculine* (bottom) in nine countries.

## RESULTS AND DISCUSSION

### Colour structure of concepts *feminine* and *masculine* in different cultures

In total, the final dataset included 19,604 responses, 1,508 of which represented colour associations to the words *feminine* and *masculine* (Figure 1).

#### Associations with hue

The strongest associations with hue for the term *feminine* were similar in all countries and in accord with previous findings (see e.g., Frassanito and Pettorini 2008, Pastoureau 2016) referred to the red (R) (41-70%) and purple (RB) (15-35%) parts of colour spectrum (Figure 2 top).

The most popular hue connected with the word *masculine* in Germany, Sweden, Japan, Iran, and Uganda was blue (B) (41-62%). In Russia, Turkey, and Saudi Arabia were additionally revealed strong associations with achromatic colours (N) (30-35%). In Nepal subjects often associated the term *masculine* with dark shades of red (R) (23%) (Figure 2 bottom).

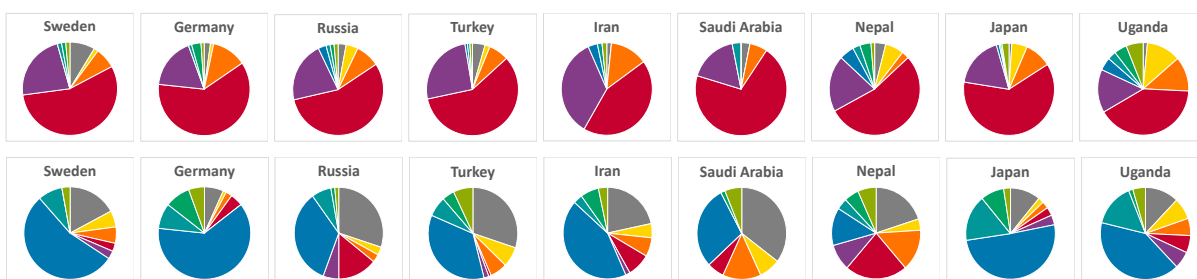

Figure 2: Associations with hue for the words *feminine* (top) and *masculine* (bottom) in nine countries.

#### Associations with groups of shades

The distribution of associations in groups of shades showed a curious pattern: colours of *feminine* in all countries except Turkey were predominantly formed with the use of light shades (56-83%), while among the colours of *masculine* dark shades prevailed (55-74%) in all countries except Japan (Figure 3).

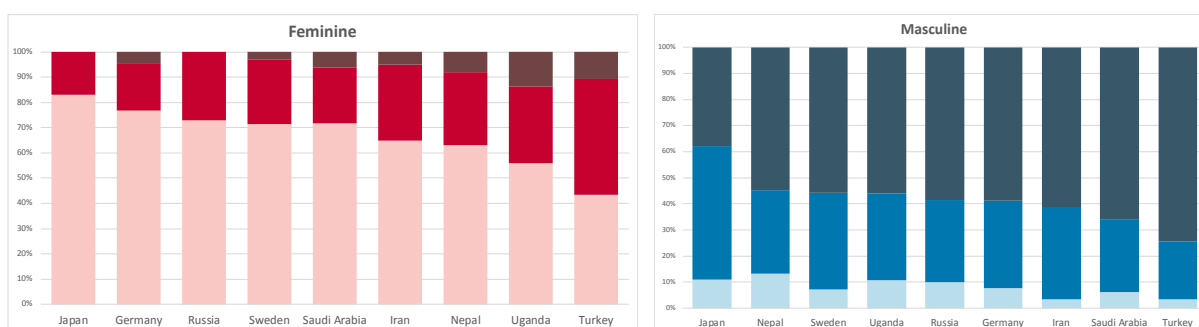

Figure 3: Associations with groups of shades for the words *feminine* (left) and *masculine* (right) in nine countries.

#### Cluster analysis

Two complimentary multidimensional approaches, a non-hierarchical K-means algorithm (see e.g. Hartigan and Wong 1979) and a hierarchical Ward's clustering method (Ward 1963), were implemented to identify groups of countries based on the colour associations to the concepts

*feminine* and *masculine*. From an application point of view, this work is based on the use of an R library (Roberts et al. 2014). The results obtained from the K-means clustering and Ward’s clustering are respectively presented in the Figures 4 and 5.

Figure 4 shows similarity in colour associations to the term *feminine* between Sweden, Germany, Russia, Japan, and Nepal, together with the specific character of these links in Iran, Turkey, Saudi Arabia, and Uganda. Regarding the colour associations to the word *masculine*, this figure shows that Russia, Turkey, and Saudi Arabia locate in one and the same cluster, Germany shares similarity with Sweden, Japan is similar to Uganda, whereas Nepal and Iran demonstrate their specific nature.

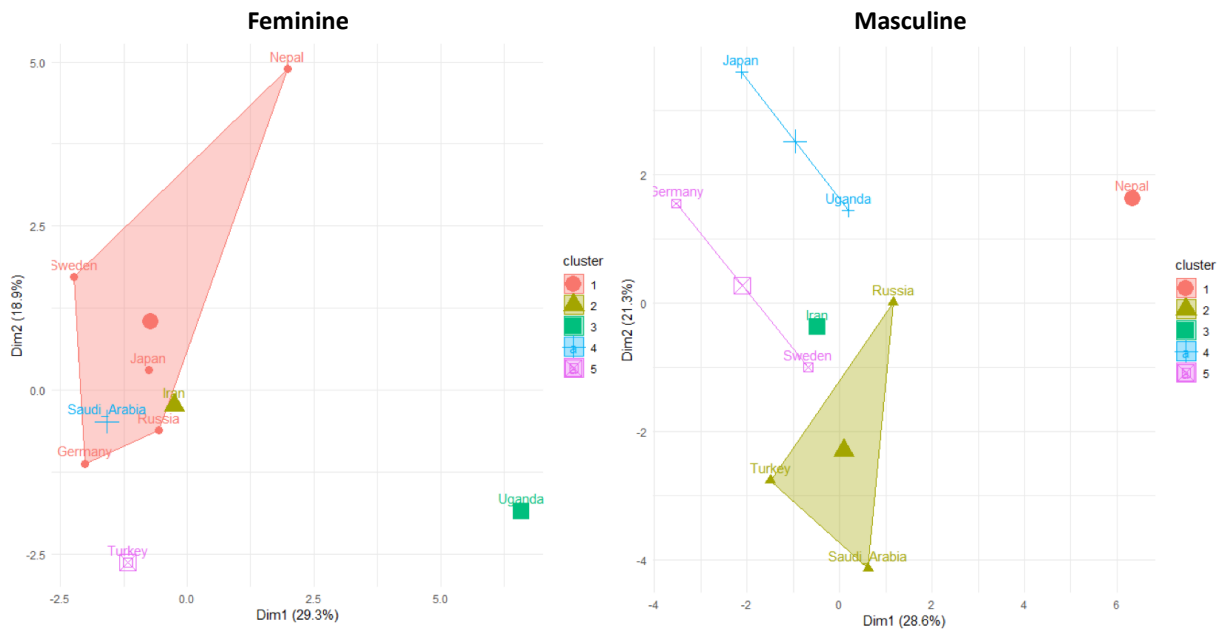

Figure 4: Inter-country adjacencies in color associations to the words *feminine* (left) and *masculine* (right) represented as K-means clusters (k = 5).

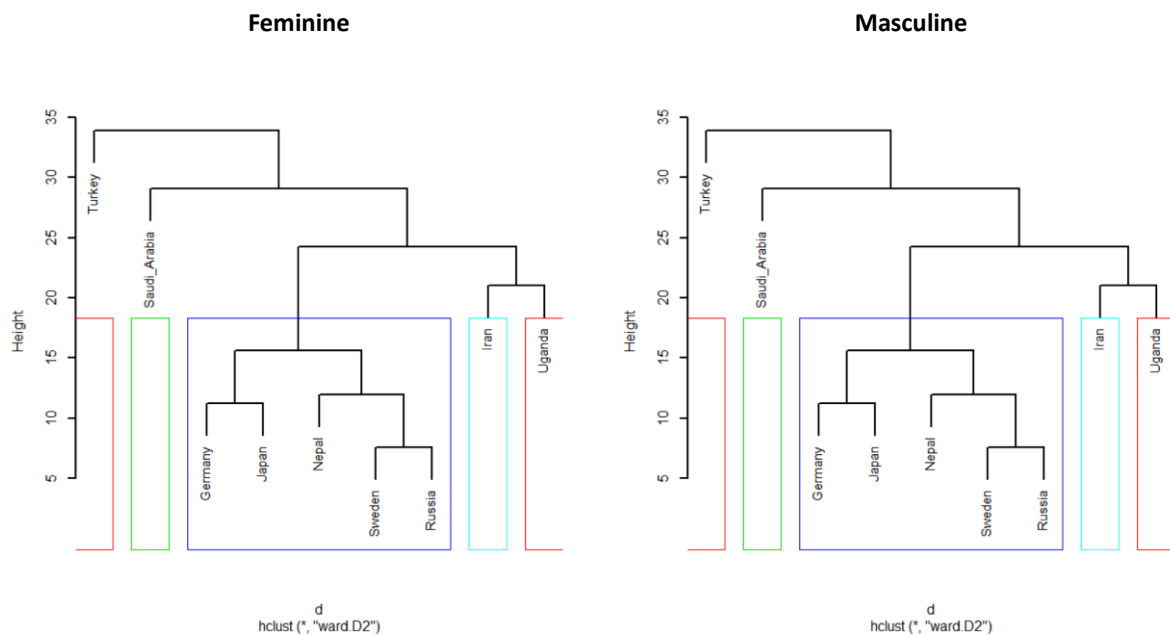

Figure 5: Inter-country adjacencies in color associations to the words *feminine* (left) and *masculine* (right) represented as dendrogram.

The outcome of Ward's algorithm plotted as a tree diagram (dendrogram) (Figure 5) confirms the previous result, but offers also a hierarchical view of the clusters. The hierarchical analysis highlights the specific character of the colour associations to the term *feminine* in Sweden and Russia that are in the same group as Germany, Japan and Nepal. With regard to the word *masculine*, Turkey and Saudi Arabia appear in a separate sub-cluster that suggests that colour associations revealed in these countries are quite different from Russia that is in the same group.

## CONCLUSION

On the whole, the use of colour samples as stimuli and directed selection of associations allowed us to conduct a quantitative analysis of the chromatic structure of the concepts *feminine* and *masculine*. We were able to specify hue, lightness and saturation of shades forming colour associations and to visualize chromatic images related to these concepts in nine different cultures. The experimental method, its procedure and approved principles of colour association, could be applied for structuring the chromatic images of other anthropologically relevant concepts. The research possesses wide prospects for further development, based on the material of other cultures, together with a potential for considerable application. The obtained results could be valuable in compiling topical dictionaries and reference books, teaching activities, as well as contributing to a great spectrum of practical tasks in architecture, design and advertising communication.

## ACKNOWLEDGEMENTS

The authors would like to acknowledge Berit Bergström and her team at Natural Colour System for colour samples. Yulia A. Griber was supported by the Grant 17-29-09145 from the Russian Foundation for Basic Research (RFBR).

## REFERENCES

- Frassanito, P., and B. Pettorini. 2008. Pink and blue: the colour of gender. *Child's Nervous System* 24 (8): 881-882.
- Hartigan, J. A., and M. A. Wong. 1979. Algorithm as 136: A k-means clustering algorithm. *Journal of the Royal Statistical Society. Series C (Applied Statistics)* 28 (1): 100-108.
- Jung, I. 2016. What are the colours of the words 'Me' and 'Others'. In: *AIC 2016 Color in urban life: images, objects and spaces*, I. C. Ivanovic, ed. Santiago: Asociación Chilena del Color, 188-191.
- Paechter, C. 2006. Masculine femininities/feminine masculinities: power, identities and gender. *Gender and Education* 18 (3): 253-263.
- Pastoureau, M. 2016. Rose Barbie. In: *Barbie, exposition*, A. Monier, ed. Paris: Musée des Arts décoratifs, 92-98.
- Roberts, M. E., B. M. Stewart, and D. Tingley. 2014. R package for structural topic models. R package version 0.6 1.
- Spence, J. T. 1984. Gender identity and its implications for the concepts of masculinity and femininity. *Nebraska Symposium on Motivation* 32: 59-95.
- Ward, J. H. 1963. Hierarchical grouping to optimize an objective function. *Journal of the American Statistical Association* 58: 236-244.

## Colour and landscape in Octavio Paz's *Libertad bajo palabra* [*Parole*] (1935-1957)

Daniela Evangelina Chazarreta

Universidad Nacional de La Plata, and CONICET, Buenos Aires, Argentina  
dchazarreta@fahce.unlp.edu.ar, dechazarreta@gmail.com

### ABSTRACT

The purpose of this paper is to analyze the colour significations in Octavio Paz's *Libertad bajo palabra* [*Parole*] (1935-1957) in relation to the landscape reflected in the figures of the garden and the paramo. The landscape is considered as a figure of nature (Silvestri 2011) and it is found in many literary texts. These texts are conceived as places where the social, cultural and aesthetic reflections are viable and fruitful (Collot 2011, Ferreira Alves and Feitosa 2010). This is the case of *Libertad bajo palabra* [*Parole*] (1935-1957): a book of poems displaying a lean palette principally and exclusively composed of green, sepia and gold.

The first two colours are linked to the settings designed throughout the book: the garden and the paramo. Gold is related to the poetry of light which can also be found in *Libertad bajo palabra*. Significantly, green is the predominant colour throughout the poems. Firstly, I am interested in highlighting that Paz's taste for colour derives from the need to renew the poetic strategies which take modern poetry as a model (Hamburger 1982). In this context, it is important to consider the relationship between poetry and visual arts (Manrique 1974). Secondly, I am interested in considering that green symbolizes the fullness of life, transcendence and nature (one of the most fundamental categories in *Libertad bajo palabra*). Finally, sepia recovers the landscape of the paramo representing the creative aridity of the poet and the alienation of the modern human being. The paramo is opposed to the garden, which suggests harmony. The garden, then, implies the appropriation of nature since nature is conceived as the perfect orb but inaccessible to the human being. This appropriation is set by means of analogy.

By focusing on the landscape, Octavio Paz can build two interesting poetic strategies. On the one hand, he is able to distance himself from the nationalistic aesthetics' parameters (Diego Rivera's muralism is a good example of this); on the other hand, he is allowed to build his own culture from universal categories (landscape and colour). In this case, he is able to express his own through a universally intelligible language (the long-established tradition of the landscape and the tradition of modern poetry in the symbolic use of colour).

**Keywords:** colour, landscape, Octavio Paz



# “Edible” colour names: age-related differences in Russian

Yulia A. Griber<sup>a\*</sup>, Galina V. Paramei<sup>b</sup>, Dimitris Mylonas<sup>c</sup>

<sup>a</sup> Smolensk State University, Smolensk, Russia

<sup>b</sup> Liverpool Hope University, Liverpool, UK

<sup>c</sup> University College London, London, UK

\* y.griber@gmail.com

## ABSTRACT

The present study is an age-group analysis of Russian colour terms (CTs) derived from names of food objects and edible substances. CTs were elicited in a web-based experiment using an unconstrained colour-naming method. Respondents, native Russian speakers (N = 2,457), were aged between 16-95 years. In the analysis, data were stratified for seven age cohorts: 16-19, 20-29, 30-39, etc., the eldest group being  $\geq 70$  years old. For each age group, we estimated (1) frequency of occurrence of individual CTs; (2) the list of “edible” categories and the inventory of CTs in each category; (3) the number of descriptors derived from individual “edible” object names (the term’s derivational productivity). Similarities in age-groups’ inventories of “edible” colour names were visualized using the hierarchical Ward’s clustering method. The findings indicate considerable age-related variation in CT referents, which we attribute to last-decades’ marked changes in social, including “gastronomic”, reality of Russian speakers.

**Keywords:** “Edible” colour terms, Russian, age-related differences

## INTRODUCTION

Across languages, studies provide evidence that richness and linguistic refinement of colour-term vocabulary differs markedly among representatives of different age groups. In particular, it was shown that the number of object-derived colour names, compared to nonspecific ones, varies in different age groups (Simpson and Tarrant 1991), with older people manifesting less extensive colour space partitioning (Kay 1975), but richer colour lexicon than younger speakers (Samarina 2007). However, systematic exploration of colour-naming patterns of speakers from different age groups of a certain language, to our knowledge, is hardly existent; the situation pertains to Russian language as well.

With the aim to stratify participants’ responses according to age groups, in the present study we extended our earlier analysis of Russian colour terms derived from names of food objects and edible substances (Griber et al. 2018). Metonymically, such “edible” colour names stand for colour of the

objects in question. In modern Russian language, they, too, constitute a substantial number of non-basic colour terms (non-BCTs).

## EXPERIMENT

Colour names were elicited in a web-based psycholinguistic experiment (Mylonas and MacDonald 2010, <http://colournaming.com>). Colour samples (N = 606 in total) were approximately uniformly distributed in the Munsell Renotation Dataset with an addition of 8 samples at the corners of the sRGB cube and 9 neutral samples. An unconstrained colour-naming method was employed: observers were free to name any number of randomly selected colour samples using any colour descriptor in Russian, either a single word, or a compound, or term(s) with modifiers or qualifiers. In addition, information about the participant's residency, nationality, language proficiency, educational level, age, gender, and colour competence was collected.

Respondents, native speakers of Russian (N = 2,457; 1,402 females), were aged between 16 and 95 years (mean age 42.54, SD = 17.71). They typed their responses using a Cyrillic alphabet. The participant sample was drawn using a combination of several sampling schemes. At an initial stage (n < 1000), we used a simple random sampling. This was followed by a stratified sampling, distinguishing seven age groups: 16-19, 20-29, 30-39 years, and so on, with the eldest group being 70 years and over.

The dataset included 55,818 responses; those of observers with normal colour vision were only considered. Of all responses, 18,300 (33%) contained object-derived colour terms; 6,811 (12%) of these were derived from names of food objects and edible substances (Figure 1).

For each age group, we estimated the following linguistic measures:

- (i) frequency of occurrence of individual colour terms;
- (ii) the list of "edible" categories and the inventory of colour names in each category;
- (iii) the patterns and number of mono- and polylexemic descriptors derived from each "edible" object name (the term's derivational productivity).

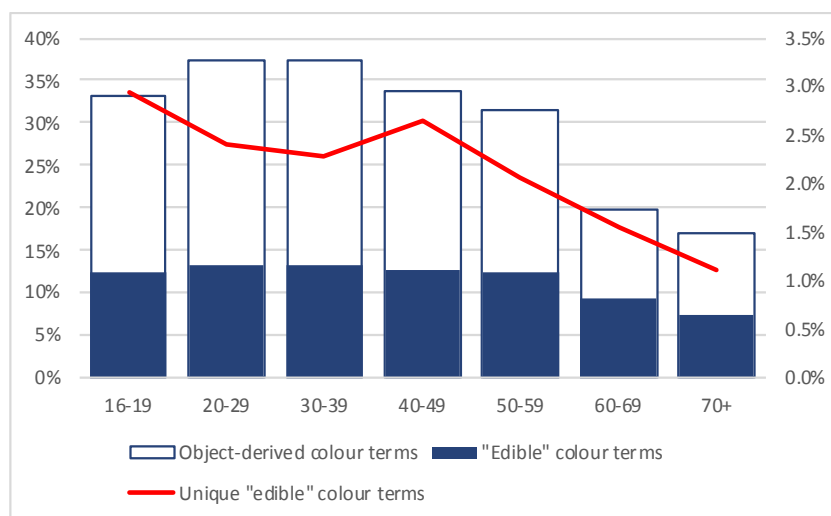

Figure 1: Percentage of occurrence of object-derived and, specifically, "edible" colour terms in different age groups (left axis) and of distinct "edible" colour names elicited in each age group (right axis) of Russian speakers.

## RESULTS AND DISCUSSION

### (i) Frequency of occurrence of “edible” colour names in different age groups

Initially, we compared frequency of recurring “edible” colour names in different age groups. It appeared that six out of the ten most frequent non-BCTs were similar in all age groups, namely, *salatovyj* “lettuce-coloured”, *bordovyj* “claret” (and its nominalized version *bordo*), *malinovyj* “raspberry”, *persikovyj* “peach”, *gorčičnyj* “mustard-coloured”, and *mâtnyj* “mint”, although the name ranking varied slightly among the groups (highlighted by blue in Table 1). The first three of these –*salatovyj*, *bordovyj/bordo*, and *malinovyj*– were offered most frequently (cf. Paramei et al. 2018).

The inventory of other most frequent colour names revealed, in comparison, age-related differences. The following names were specific for individual age groups (given in bold in Table 1): *tëmno-bordovyj* “dark claret” was frequently offered only by the youngest group (16-19 years); *svekol'nyj* “beetroot” was frequently offered in the 40-49 years group; *višněvyj* “cherry-coloured” was high in frequency for respondents over 50; *morkovnyj* “carrot” occurred among frequent “edible” names in the 60-69 years group. Conversely, “negative” age-group colour-naming referents were observed: the recurring term *slivovyj* “plum” (Table 1, in purple) was not among the most frequent terms of participants aged 40-49 or 60-69 years; another recurring term, *olivkovyj* “olive” (Table 1, in olive), did not occur among frequent lists of participants over 60 years.

	16-19	20-29	30-39	40-49	50-59	60-69	70+
1	salatovyj	salatovyj	salatovyj	salatovyj	salatovyj	bordovyj	Salatovyj
2	bordovyj	bordovyj	bordovyj	bordovyj	bordovyj	salatovyj	bordovyj
3	persikovyj	malinovyj	malinovyj	malinovyj	malinovyj	persikovyj	persikovyj
4	malinovyj	gorčičnyj	gorčičnyj	gorčičnyj	persikovyj	malinovyj	malinovyj
5	gorčičnyj	persikovyj	mâtnyj	persikovyj	gorčičnyj	gorčičnyj	slivovyj
6	mâtnyj	mâtnyj	persikovyj	fistaškovyj	mâtnyj	mâtnyj	mâtnyj
7	slivovyj	baklažanovyj	limonnyj	olivkovyj	bordo	višněvyj	višněvyj
8	bordo	slivovyj	bordo	svekol'nyj	olivkovyj	limonnyj	gorčičnyj
9	olivkovyj	limonnyj	slivovyj	mâtnyj	višněvyj	morkovnyj	baklažanovyj
10	tëmno-bordovyj	olivkovyj	olivkovyj	limonnyj	slivovyj	baklažanovyj	limonnyj

Table 1: Ten most frequent “edible” colour names elicited in different age groups of Russian speakers.

### (ii) The list of “edible” categories and the inventory of colour names in each category

Following our previous classification (Griber et al. 2018), in the present study we also focused on 14 specific categories of “edible” objects, functioning as colour-term referents –Fruits, Vegetables, Berries, Herbs, Nuts, Cereals, Spices, Fish, Poultry, Dairy products, Sweets, Alcohol, Hot and Soft Drinks– and compared their inventories in different age groups. For all age groups, among the most common “edible” object categories as colour-term referents were Fruits and Berries. Furthermore, participants under 40 years frequently referred to Sweets; in comparison, respondents over 50 years eagerly named colours using various Vegetables (Figure 2, Table 2).

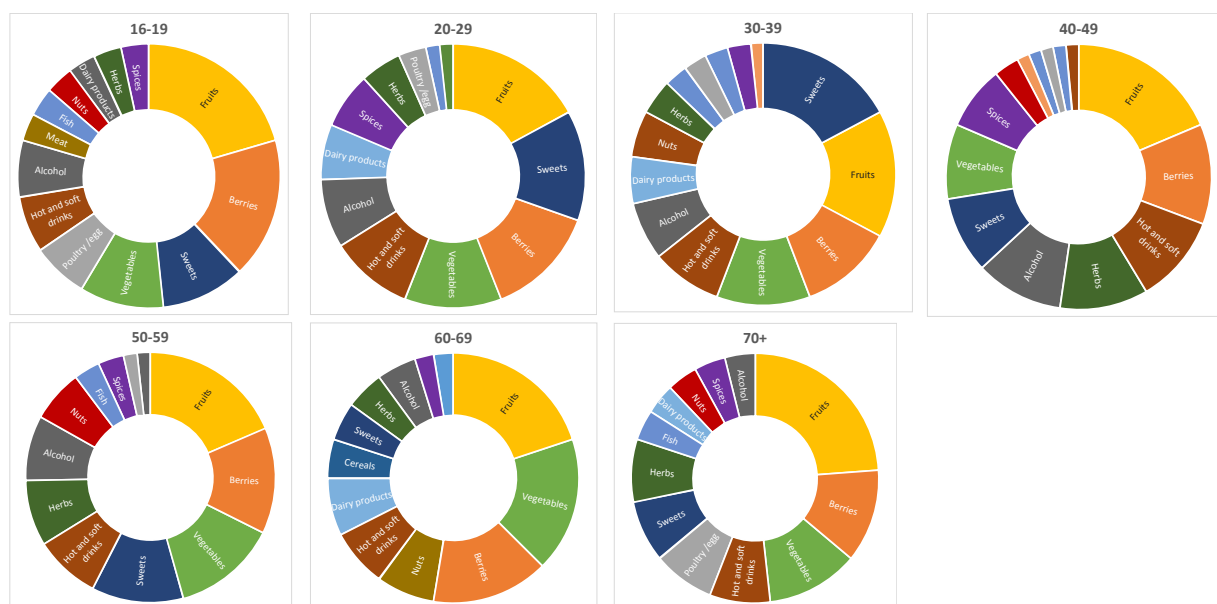

Figure 2: Categories of “edible” objects referred to in colour names by different age groups of Russian speakers.

### (iii) The patterns and number of mono- and polylexemic descriptors derived from individual “edible” object names (the term’s derivational productivity)

In all age groups, colour terms derived from names of “edible” objects constituted a significant number: in total, among 3,128 unique colour words in the Russian dataset we identified 2,297 terms (73%) derived from names of objects, with nearly one third of them, 690 (22%), derived from the names of food objects and edible substances.

The most frequent colour terms, in all age groups, also revealed rich derivational productivity, i.e. the variety of unique mono- and polylexemic descriptors derived from the object name. The greatest variety of descriptors, in the age groups 16-19 and 50-59 years, was obtained for *salatovyj* “lettuce-coloured” (8 and 17 respectively), and in all other groups for *bordovyj/bordo* “claret” (between 5-29 derivatives in different age groups).

Noteworthy, the proportion of polylexemic colour terms derived from food objects and edible substances appears to decrease with age (Figure 3, left). Compared to younger respondents, participants over 60 years offered more often monolexemic “edible” colour terms (e.g. *persikovyj* “peach”), while much less frequently double and triple compound colour terms (e.g. *vinno-krasnyj* “wine-red”; *žélto-zelenovato-gorčičnyj* “yellow-greenish-mustard”) or colour terms with achromatic modifiers, such as *svetlo-* “light”, *tëmno-* “dark”, *jarko-* “bright”, *tusklo-* “dull”, *bledno-* “pale”, *nežno-* “tender”, or *grâzno-* “dirty”. Conversely, participants in the age between 20–39 years eagerly used unusual objects as referents, as well as complex patterns entirely absent in the lexicon of other age groups, such as *klubnika so slivkami* “strawberry with cream”, *melanzana* “melanzane” (an Italian classic bake with aubergines, tomato and cheese), *moloko s ostatkami kofe* “milk with coffee residue”.

Furthermore, to name colour stimuli, participants aged between 20-59 years more frequently than respondents from younger or older age groups employed the model “*cveta X*” (“colour of X”) (e.g. *cvet golubiki* “colour of bilberry”) or the object-noun model “X”, as a compound or modifier (e.g. *višnâ* “cherry”), rather than traditional Russian-language suffixed adjectival forms (e.g. *višnëvyj* “cherry-coloured”) (Figure 3, right).

Category	Inventory of colour-term referents	Total	16-19	20-29	30-39	40-49	50-59	60-69	70+
Fruits	<i>abrikos</i> "apricot", <i>apel'sin</i> "orange", <i>arbuz</i> "watermelon", <i>banan</i> "banana", <i>citrus</i> "citrus", <i>frukt</i> "fruit", <i>granat</i> "pomegranate", <i>gruša</i> "pear", <i>jabloko</i> "apple", <i>kuraga</i> "dried apricot", <i>lajm</i> "lime", <i>limon</i> "lemon", <i>mandarin</i> "tangerine", <i>maslina</i> "black olive", <i>olivka</i> "(green) olive", <i>persik</i> "peach", <i>sliva</i> "plum"	17	6	10	11	12	11	8	6
Sweets	<i>huba buba</i> "Hubba Bubba", <i>karamel</i> "caramel", <i>krem</i> "custard", <i>konfeta</i> "candy", <i>ledenec</i> "lollipop", <i>mëd</i> "honey", <i>moroženoe</i> "ice cream", <i>pastila</i> "pastila", <i>pečen'e</i> "cookie", <i>plombir</i> "Plombir ice cream", <i>sorbet</i> "sorbet", <i>šerbet</i> "sherbet", <i>šokolad</i> "chocolate", <i>vanil'</i> "vanilla", <i>varen'e</i> "jam", <i>žvačka</i> "bubble gum"	16	3	8	12	6	7	2	2
Vegetables	<i>asparagus</i> "asparagus", <i>baklažan</i> "aubergine", <i>gorokh</i> "pea", <i>kabačok</i> "squash", <i>kapusta</i> "cabbage", <i>kartofel'</i> "potato", <i>morkov'</i> "carrot", <i>ogurec</i> "cucumber", <i>paprika</i> "paprika", <i>perec</i> "pepper", <i>pomidor</i> , <i>tomat</i> "tomato", <i>salat</i> "lettuce", <i>svëkla</i> "beetroot", <i>tykva</i> "pumpkin"	14	3	7	8	6	8	7	3
Berries	<i>brusnika</i> "cowberry", <i>černika</i> "blueberry", <i>čerešnâ</i> "sweet cherry", <i>eževika</i> "blackberry", <i>golubika</i> "bilberry", <i>jagoda</i> "berry", <i>klubnika</i> "strawberry", <i>klûkva</i> "cranberry", <i>malina</i> "raspberry", <i>râbina</i> "rowan berry", <i>vinograd</i> "grape", <i>višnâ</i> "cherry, cerise"	12	5	8	8	8	8	6	3
Herbs	<i>koriandr</i> "coriander", <i>lemongrass</i> "lemongrass", <i>lipa</i> "lime", <i>lën</i> "flax", <i>mâta</i> "mint", <i>raps</i> "rapeseed", <i>tabak</i> "tobacco", <i>vodorosl'</i> "sea weed", <i>zelen'</i> "potherbs"	9	1	3	3	7	5	2	2
Alcohol	<i>bordo</i> "bordeaux, claret", <i>burgundskij</i> "burgundy", <i>likër</i> "liqueur", <i>marsala</i> "marsala", <i>portvejn</i> "port wine", <i>punš</i> "punch", <i>šampan</i> "champagne", <i>šartrež</i> "chartreuse", <i>vino</i> "wine"	9	2	5	5	7	5	2	1
Hot and soft drinks	<i>čaj</i> "tea", <i>espresso</i> "espresso", <i>kakao</i> "cocoa", <i>kapučino</i> "cappuccino", <i>kofo</i> "coffee", <i>koktejl'</i> "cocktail", <i>mokko</i> "mocha", <i>sok</i> "juice", <i>voda</i> "water"	9	2	6	6	7	5	3	2
Dairy products	<i>jogurt</i> "yoghurt", <i>maslo</i> "butter", <i>moloko</i> "milk", <i>slivki</i> "cream", <i>smetana</i> "sour cream", <i>syr</i> "cheese", <i>tvorog</i> "cottage cheese"	7	1	4	4	1	1	3	1
Nuts	<i>fistaška</i> "pistachio", <i>funduk</i> "hazel nut", <i>kaštan</i> "maroon", <i>kedrovij orekh</i> "pine nut", <i>mindal'</i> "almond", <i>orekh</i> "nut"	6	1	1	4	2	4	3	1
Spices	<i>gorčica</i> "mustard", <i>karri</i> "curry", <i>korica</i> "cinnamon", <i>mentol</i> "menthol", <i>šafran</i> "saffron"	5	1	4	2	5	2	1	1
Cereals	<i>kukuruza</i> "maize", <i>pšenica</i> "wheat", <i>rož'</i> "rye"	3	0	0	2	1	0	2	0
Poultry	<i>jaičnaâ skorlupa</i> "egg shell", <i>želtok</i> "egg yolk"	2	2	2	2	1	1	0	2
Fish	<i>losos'</i> , <i>selman</i> "salmon"	1	1	1	1	1	1	1	1
<b>Total</b>		<b>110</b>	<b>28</b>	<b>59</b>	<b>68</b>	<b>64</b>	<b>58</b>	<b>40</b>	<b>25</b>

Table 2: Inventory of frequent "edible" referent objects in different age groups of Russian speakers.

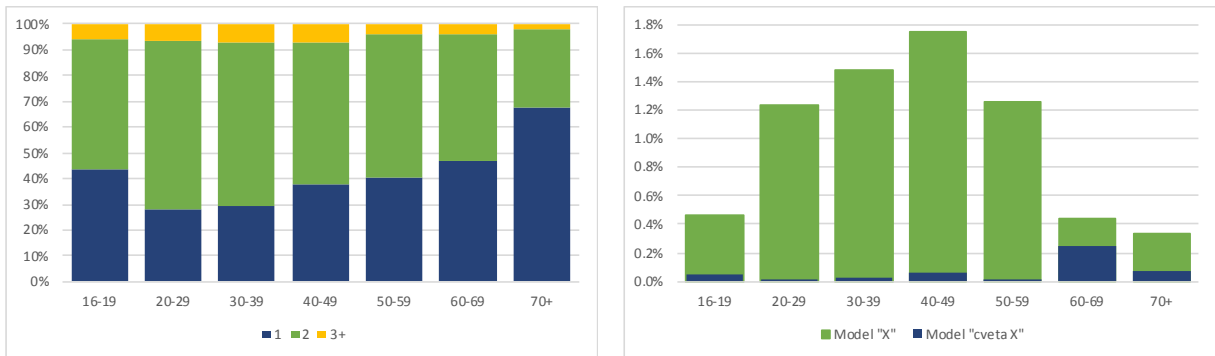

Figure 3: Percentage of colour descriptors with varying number of words in Russian speakers' different age groups (left); frequency of occurrence of the model "cveta X" ("colour of X") and object-noun model "X" (right).

**(iv) Visualizing similarities between different age groups in inventories of "edible" colour names**

To visualize similarities between different age groups in inventories of "edible" colour names, we implemented a hierarchical Ward's clustering method (Ward 1963). The dendrogram (Figure 4) prompts that participants 20-29 and 30-39 (born between 1980-1999) fall into one cluster; in comparison, the 60-69 years group shares similarity with the 40-49 and 50-59 years groups (respondents born between 1950-1979); while the 16-19 year old are similar to those aged 70 and above.

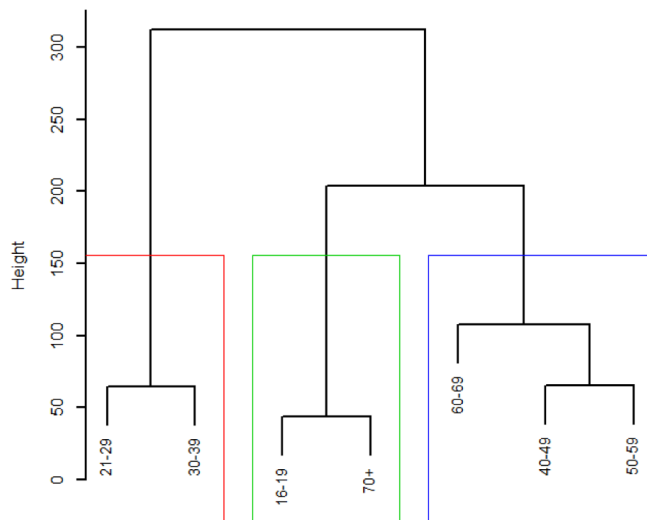

Figure 4: Dendrogram representing inter-age group adjacencies in inventories of "edible" colour names.

**CONCLUSION**

The present findings indicate that colour-term referents and patterns of naming colour vary considerably between age groups. We attribute the revealed differences to dramatic social and economic changes in the Russian society during last decades and, hence, in life experience of informant age cohorts. The inventory of "edible" colour terms is supposed to reflect the diversity of "gastronomic" reality of different age groups of Russian speakers –their characteristic cuisine, the array of available food products (marked by substantial influx of Western products after 1991) and, as a result, inter-generational shift in "semantic anchors" in naming colours.

## ACKNOWLEDGEMENTS

Yulia A. Griber was supported by the Grant 17-29-09145 from the Russian Foundation for Basic Research (RFBR).

## REFERENCES

- Griber, Y. A., D. Mylonas, and G. V. Paramei. 2018. Objects as culture-specific referents of colour terms in Russian. *Color Research and Application* 43 (6): 958-975.
- Kay, P. 1975. Synchronic variability and diachronic change in basic color terms. *Language in Society* 4 (3): 257-270.
- Mylonas, D., and L. MacDonald. 2010. Online colour naming experiment using Munsell colour samples. In: *Proceedings of the 5th European Conference on Colour in Graphics, Imaging, and Vision (CGIV)*. Springfield: IS&T, 27-32.
- Paramei, G. V., Y. A. Griber, and D. Mylonas. 2018. An online colour naming experiment in Russian using Munsell colour samples. *Color Research and Application* 43 (3): 358-374.
- Samarina, L. V. 2007. Gender, age, and descriptive colour terminology in some Caucasus cultures. In: *Anthropology of colour: interdisciplinary multilevel modeling*, R. E. MacLaury, G. V. Paramei, and D. Dedrick, eds. Amsterdam: John Benjamins, 457-466.
- Simpson, J., and A. W. S. Tarrant. 1991. Sex- and age-related differences in colour vocabulary. *Language and Speech* 34 (1): 57-62.
- Ward, J. H. 1963. Hierarchical grouping to optimize an objective function. *Journal of the American Statistical Association* 58 (301): 236-244.

# Black, white and red: archetypes and symbols

**Renata Pompas, Lia Luzzatto**

Accademia del Lusso, Milan, Italy  
renata.pompas@gmail.com, luzzattolia@gmail.com

## **ABSTRACT**

Colour is a complex cultural construction, a rebel against generalisations, something to which we assign values, qualities and meaning.

In our lengthy experience in teaching about colour and its role in the visual project, in addition to colour theory, we have always also analysed its emotive and communicative aspects. But we still wonder to this day to what extent students perceive the difference between the archetypal, and therefore universal meanings, and those symbolic meanings specific to the culture they belong. We are talking about archetypes and symbols of articulated situations where, if one does not grasp diversity, in today's globalised world, one risks formulating imperfect or ineffective communication. For this reason, it is important, in research and education about colour, to begin with knowing its archetypes, understood in their supra-historical and supra-geographical sense, followed by the symbolic garland that each culture has developed in an independent manner.

In its symbolic declinations colour has represented the property which renders intelligible to the eye the meaning concealed behind the surface: the image of the mystical in nature, of the transcendent within the immanent, of the hidden properties of interdependent elements which, according to ancient knowledge, formed the universe.

As a means to knowledge and interpretation of the real and as energetic form able to interact with the natural forces, in archaic societies colour has been an instrument of medicine and magic; as image of mystical forms and of their relationships within creation it has coloured religious language; as mark of belonging or exclusion it has characterised social life organising itself in codes.

This work analyses the universal meanings of colours which over time have specialised historically, namely the progress from archetype to symbol, leading an inquiry through ancient religions, cosmogenic tales on the formation of the Universe and the myths of civilizations that developed around the Mediterranean sea, cradle of European society, taking as an exemplificative title the three principal colours from an anthropological point of view: black, white and red.

This is an exploratory and comparative survey on the archetype of colours and their structuration in symbols born to reveal the inexpressible through colours, which concludes with an observation on contemporaneity, where despite the destructuration of society, the archetypal meaning endures, while the symbols which developed over centuries starting from the original meaning have become fluid and evanescent along the way, and they are now used irrespectively in



social and communication contexts where they continue to change sense according to the environment in which they are found.

**Keywords:** *education, identity & heritage, colour descriptions in literature*

## 1. INTRODUCTION

Why teaching *chromatic archetypes* in colour modules? We think that archetypes are a way to analyse and to use leverage on the socio-cultural imaginary, with the intent of realising a project able to insert itself in the lives of social groups the project and communication are addressing.

Colour archetypes present themselves as a basic dominant in the forest of symbols which over the centuries have woven together, a dominant devoid of time and space that on occasion asserts itself with a clarity which traverses the planes of symbolic syncretism, and speaks with strength and empathy.

For example, going to the root of the *black* archetype and of its primordial garland of symbols (marks which have themselves become archetypes) allows us to go deeper and therefore communicate with young rebel groups who utilize this colour as a mark of themselves, rather it allows us to penetrate the imaginary of youth sub-cultures such as Punk, Goth, Metal, etc. For these anarchic groups black expresses not only anger, but also hope for a new form of life: a compressed and germinative black.

We are talking about comprehending the original forms of human experience, not dependent on latitude or on how this experience is nourished and amplified by diversity along its course, expanding into garlands of symbols pertinent to each society.

In this way the *white* archetype promotes symbols of life and death which differ from East to West. Archetypes unite humanity in the primal experience: think of the universal primitive custom of smearing the dead with *red* ochre, a representation of the red archetype intended as blood, repository and generator of life.

## 2. ARCHETYPAL BLACK

Looking far back in time we find that all of the myths on the origin of the universe and of our world, view this colour as without time and without place, a matrix colour, the gestating uterus whence all worlds came. A universal, primal image, which represents the preceding phase to creation, a phase which contains in embryo the energy and potentialities that will spawn the universe. Hence the archetype of black becomes as primordial substance, in its twofold aspect of absence of presence, of empty and full, of rarefaction and concentration, of turmoil and latency, where uncreated forms lie promiscuous in undifferentiated chaos.

By the same token, according to the Phoenicians, “in the beginning there was a sombre darkness, devoid of spatial confines and eternal” (Wincler 1992). For the Egyptians there was: “The Infinite, the Void, the Inexistent and the Darkness”. For the peoples of ancient Mesopotamia, Sumerians and later Babylonians, the god Marduk was born in the centre of the Abyss: “in his dark room, in the place of destinies, in the domain of determinations”.<sup>1</sup> In a similar way, among the peoples we gather under

---

<sup>1</sup> *Enuma Elish (Il poema della creazione)* (in Furlani 1958).

the name of Greek, black stood out and could be found expressed or alluded to in the darkness of primeval chaos, in that: “primordial void” where the gods originated (Hesiod, *Teogonia*). And lastly, among the Jews, primeval chaos was described as a boundless vacuum where: “darkness was on the verge of the abyss” (*Genesis* I: 1-2).

Leaving the Mediterranean, we also find that in the Chinese Taoist representation of creation, in the beginning there was a black, gloomy chaos, which slowly took on the form of the cosmic egg, cradle of Pangù, the first living being, who emerging from the egg, crushed it, igniting creation and the complementary forces of *Yin e Yang*.

## 2.1 Black from archetype to symbol

Over time a garland of symbols has taken structure around this primordial cornerstone of the understanding of the universe, which gradually has been enriched or impoverished by new and old meanings. Those symbols that refer to all things chthonic and subterranean, are still alive today in the socio-cultural imaginary and are utilised in language as much as in a lot of visual production.

Given that black was antecedent to Creation, in ancient times it also became its conclusion, in religions it characterised anything pertinent to the Kingdom of the Dead: they were dark and forsaken lands, like the place described in the Egyptian “Book of the Dead”: “Everywhere I cannot hear, nor anything do I perceive, in the deep shadows surrounding me, what chasms and what abysses! What opaque gloom” (*Book of the Dead*). Analogous were also the “The gloomy [and] deep Tartarus” (Homer, *Iliad*, VIII, 13 & 481) of the Greek and the “Land-of-no-return” of the “Netherworld” enveloped in shadows of the Sumerian and Babylonian civilisations, described in “Ishtar’s descent into the Pit”<sup>2</sup> and also: “The home of shadows seat of Ircalla [...] the home where those who enter are deprived of light, there where their nourishment is dust, mud is their food, light they cannot see, in the shadows they sit”. It is a desolate landscape reminiscent of nature in sterile volcanic terrains, image of nature’s demise.

These values were passed down through the ages: death-black was employed for example on the facades of houses in XVII century Amsterdam, to signal the presence of the plague, while nowadays it darkens the landscapes in films describing a dystopian future.

After becoming a symbol of wealth in the funerary ceremonies of the powerful, black acquired a new meaning of exclusivity and elegance. A sumptuous black, launched in Europe when dyers in the Middle Ages succeeded in dyeing magnificent black velvets, of a deep and brilliant hue, that nowadays is present in fashion with this meaning, as seen in Givenchy’s recent show; in design and architecture, as in the black walls of some interiors, see the GAM museum in Bergamo and New York’s Hublot Store: a black tower covered in aluminium panels, partly lit up by LED.

## 3. ARCHETYPAL WHITE

“Speaking of light, especially in its anthropological, cultural and religious declinations, entails referring not only to the history of mankind, but also to the history of the universe” (Burgalassi 2000) and this road takes us to the origins where light marks the passage from the uncreated to the created, chiefly in the Mediterranean cultures. Here white as most perfect light represents the primeval, order-inducing force contained within the shadows which, when released, ignites the

<sup>2</sup> *La discesa di Istar agli Inferi* (in Furlani 1958).

formation of the universe, transforms chaos into cosmos and gives rise to space and time. The representation of it given by ancient peoples differs according to each culture, but it is identical in the essence of its colour: white.

In Egyptian texts it is a white lotus: “mysterious and splendid, in its purity”: a five petal lotus, which, blossoming on the surface of the primeval waters, radiates into the infinite. Otherwise manifesting as a blazing effulgence: “And here I rise into the Ether of the mysterious Universe like the cosmic egg surrounded by rays”. And again as a bird in flight: “Like a great Golden Falcon, who emerges from its egg” (*Book of the Dead*: LXXXI, LXXVII, XXII). The peoples of ancient Greece also, in the elaboration of their theogony adopted the image of the divine principle intended as “pure light”, in the personification of *Phanes* (light), also known as *Protogonos* (first born) who, once emerged from the cosmic egg, flooded the universe with brilliant light and generated everything: “After him and because of him, the universe shone with light” (di Nola 1970). According to the Jewish people the representation of light is abstract and linked to the power of speech. The “*Fiat lux*” (“Let There Be Light”, Genesis I, 3-5) is the force of the ordaining and generating Word, the *Logos* which constitutes the luminous and audial manifestation of the first act of creation.

As Marco Conti has written (2000), “Unveiling becomes a quality of light so much so that the world appears or does not by virtue of this very metaphor. [...] Light and shadow in myth, seem to be more of an oxymoron, the union of two opposites so to speak, rather than an antithesis: the shadows contain light and vice-versa”.

Similarly in the beginning the light-soul of the world, defined in such a way by Jung, is freed from the matter in which it was trapped, revealing a moral and psychic order. The light of unconscious, symbol of consciousness, along with its counterpart white, is the positive pole —opposed to the black of evil and shadow— which yearns to come out of the darkness: “It was then I understood —writes Jung (1978)— that in the soul, from its inception, there has been a yearning for light and an inextinguishable impulse to come out of primitive obscurity”.

### 3.1 White from archetype to symbol

Approaching archetypes helps us to understand the original forms of human experience, regardless of latitude or how this experience is informed and amplified by diverse histories, expanding into a range of symbols inherent to each society. So the question is: how has original white favoured this diversification? We must search for the answer in the dual opposition between black and white which for all peoples has represented concepts of ending and beginning (see also Luzzatto and Pompas 1987). So it is that, in the East, mourning is white, because it heralds both death and reincarnation —sign of reunification with the light of the Beginning— while in the West it is black that expresses the mystery and the unknown of death.

Nevertheless in the West also, white was present in its funerary use: Cretan, Greek, Phoenician, Etruscan and Egyptian iconographies, are rich in imagery which represents the dead shrouded in white funerary bandages or sheets (see Luzzatto and Pompas 2002).

In fact, Homer describes the funerary rites of Patroclus’s burial: “After laying him on the bed, they shrouded him in soft linen from head to foot, and they put a white sheet on top” (*Ileucos*) (Homer, *Iliad*, XVIII). In contemporary times, the artist Alberto Burri covered in white cement, like a shroud, the village of Gibellina, destroyed by the 1968 earthquake, in his work *Il grande cretto* [*The big crack*], one of the largest landscape artworks in the world, that encapsulates the profound pain of a village, totally razed to the ground.

The whitewashing of church facades in the Middle Ages also marked an ending, that of colours as seductive elements which hampered devotion, in order to promote inner purification, just as white lime was purifying against the plague and saved the lives of Ostuni inhabitants in the 17th century.

White has traversed the centuries as the symbol of inner and outer purity. In Mediterranean civilizations, the white robes of initiates to the mysteries have represented innocence, integrity, the taking place of a catharsis. In Rome, the pure white *toga* of aspirant senators during the Republic, was a symbol of probity and righteousness. The white dress of the bride, since the 19th century, was chosen as a symbol of physical and, by extension, moral integrity, matched by the trousseau of household linen, which came once upon a time solely in this colour (see Luzzatto and Pompas 1992).

#### 4. ARCHETYPAL RED

It is archetypes that unite humanity in the primal experience. Potent, tangible and fundamental, it is the experience of red, that embraces blood so tightly as to become its archetype.

As we had the opportunity to write in our book on the meaning of colours in ancient civilisations (Luzzatto and Pompas 2017), the custom of smearing corpses with red ochre has been attested since prehistory, among all the Palaeolithic peoples of the world: from Europe, to Africa, from Australia to America. In China, red hematite was found in burial rites dating circa 20,000 BC, in an area called *Zhou Kou Dian*, a few kilometers from modern Beijing. The aim of this chromatic ritual was to return the vital force death had stolen from the bodies, to accompany them in the mysterious journey toward an unknown afterlife.

As it was established that the life principle was contained in blood, subsequently it was believed that its benevolent shedding could increase the said principle and potentise it, gifting with vigor and fertility nature and life itself. So, it was that during rituals dedicated to the gods and the dead, gory blood shedding was performed with sacrificial victims' blood and with that seeping out in the self-flagellations of priests and the followers (a custom still in use nowadays among some peoples), later substituted with red liquids, such as wine that was pouring freely in Dionysian rituals until it provoked "intoxication that plunged followers into animal unconsciousness, overstepping human condition" (Eliade 1979).

In the study of archetypes we cannot ignore the strong link between red and fire, with its either devastating or purifying force. An intense red that veers toward orange, that because of its aggressive, violent and destructive qualities, has become the image of hell, of apocalyptic catastrophes, of exterminating divinities, like the Egyptian *Seth*, the Greek *Hephaestus*, the Roman *Vulcan* and the Jewish *Satan*.

In the imaginary geography of the afterlife of many civilisations, the rivers of damnation that surround the realm of the damned, were depicted as subterranean rivers of liquid fire, visible to the living in volcanic eruptions. So it is that the Egyptians thought there was a "Lake of Fire" where the damned were lying in anguish: "those whom, there in the depths, yearn to drink to quench the thirst that torments them [...] they look to these fiery torrents and back away unable to extinguish their searing thirst" (Eliade 1979: chapter LXIII); while Romans believed the souls of the damned had to cross the "immense *Flegentonte*" on fire, on the boat led by Charon, whose "hirsute beard was soaked in fiery waters and on whose face flames would flow" (Claudian, *De raptu...*, I).

#### 4.1 Red from archetype to symbol

As a pigment and colouring matter, red has conjugated itself in a variety of hues and shades, for purposes that depart from the rituals deriving from its archetypes. Red has multiplied itself in social and religious symbols, requiring a gaze able to perceive the differences. Nowadays though we are familiar with the shades of carnelian, of jasper, of glass and other substances red in colour, used in ritual and decorative objects, we do not know exactly how many and which were the hues obtained through the many tinctures, from the more vermilion *reseda* to the intense, deep and brilliant tyrian red, that could vary according to its processing from pink, to carmine, to purplish.

We can only imagine what the tyrian red robe of the Greek goddess Aphrodite would have been like, described by Claudian in such a way, that Ovid by virtue of this colour attributed the nickname of *purpurissa* to the goddess, alluding to regality, beauty and youth (Claudian, *De raptu...*, II). Or we can imagine what the numerous hues of the precious twisted linen drapes of the Jewish tabernacle could have been, described in the Bible with these words: “ten drapes of twisted flax entwined with azure, tyrian and scarlet thread” (*Exodus XXVI*, 31), an azure that others translate as “purplish”.

The temples were decorated with these reds, and the altars and statues of the gods were draped in them. Their magnificence became over the centuries sole prerogative of emperors, kings, priests and generals, who made red in its various shades the pre-eminent colour: sacral, sophisticated or heroic, just as Plutarch succeeds in depicting it for us in his description of the Roman general Emilianus Paulus’ triumph “swathed in a tyrian-red cloak embroidered with gold” (Plutarch, *Vita di Emilio Paolo*). A precious colour which, when laid onto fabrics, since the beginning, has been symbol of power, regality and wealth. Emblem of authority and prestige, today it is still a distinguishing mark of power in the garments of magistrates and prelates, or of luxury in environments that need to flaunt or simulate magnificence and elegance.

As archetype of blood, red had a dual purpose in military uniforms of war and heroic actions of the past: on one hand, that of increasing power, of exciting rage, and on the other, being red, that of concealing spilt blood. “Red enhances our physical reactions because what we see is the beginning of danger” (Elliot and Aarts 2011).

Just one colour, which conjugated in different shades and materials, has expanded into all the symbolic meanings we have inherited from antiquity: an important legacy to comprehend when, with this colour, one can undertake a process of communication which requires a look able to detect the connections coming from so far back (see Pompas 2009, 2017, 2018).

## 5. CONCLUSIONS

The teaching of colour archetypes opens up the chance for a different type of dialogue with the chromatic experience, because it leaves superficiality behind, recovering the deep, original and creative expression, on which ideas and meanings have been grafted and articulated according to each culture. One must be aware of them when undertaking a design project in order not to make evaluation errors, like it happened with the Italian Institute of Culture building lacquer red, designed in Tokyo by Gae Aulenti, which disturbed the inhabitants’ aesthetic sensitivity with its aggressivity in the neighbourhood.

Colour offers accounts that go beyond the immobility of the mark which defines it chronologically in the present. Referring to the past and studying its course makes us aware of the fact that the time elapsed in the evolutionary history of human society contains and projects in the present

innumerable symbolic values linked to the original nucleus, which offer the possibility to recover them in a contemporary mode, to access new chromatic experiences and to formulate more complex messages.

Making chromatic archetypes known, also means bringing back alive the forgotten documents of colour archaeology and ethnography which nurture imagination and creativity.

Venturing into the rituals that have marked the evolution of colours —particularly the more ancient and rich with meaning such as black, white and red— helps us to understand their value and it is like availing of a rite of passage to glean their secrets (see also Pompas 2009a).

Therefore, viewing chromatic archetypes in light of all their richness entails learning to use them with wisdom: it is in fact sufficient to juxtapose a few chromatic marks to evoke deep meanings and to give rise to emotions.

## REFERENCES

- Book of the Dead*. Italian translation, *Libro dei morti degli antichi egiziani*, ed. G. Kolpatchy. Milan: Ceschina, 1956, chapter CLXXV.
- Burgalassi, S. 2000. La luce come archetipo e mistero. *RISK* 27, 2000.
- Claudian. *De raptu Proserpinae*. Italian translation, *Il rapimento di Proserpina*.
- Conti, M. 2000. In principio era la notte. *RISK* 27, 2000.
- di Nola, A. 1970. Grecia. In: *Enciclopedia delle religioni*. Florence: Vallecchi.
- Eliade, M. 1979. *Storia delle credenze e delle idee religiose*, 3 vol. Florence: Sansoni.
- Elliot, A. J., and H. Aarts. 2011. Perception of the colour red enhances the force and velocity of motor output. *Emotion* 11 (2): 445-449.
- Exodus XXVI, 31*: In: *La Bibbia di Gerusalemme*. Bologna: Edizioni Dehoniane, 1974.
- Furlani, G., ed. 1958. *Miti babilonesi e assiri*. Florence: Sansoni, 1958.
- Genesis I*. In: *La Bibbia di Gerusalemme*.
- Hesiod. *Teogonia*, translation by G. Arrighetti. Milan: Rizzoli, 1984.
- Homer. *Iliad*. Italian translation by G. Paduano, *Iliade*. Rome: L'Espresso, 2005.
- Jung, C. G. 1978. *Ricordi, sogni e riflessioni*. Milan: Rizzoli.
- Luzzatto, L., and R. Pompas. 1987. Bianco e nero, tra dilatazione e contrazione. *Amica*, Rizzoli.
- . 1992. Bianco progressista e morale. *Blond*, May-June 1992.
- . 2002. I colori dei faraoni. *Industria Tessile*, November-December 2002.
- . 2017. *Il significato dei colori nelle civiltà antiche*. Florence: Bompiani Giunti.
- Plutarch. Vita di Emilio Paolo. In: *Vite parallele*. Turin: Einaudi, 1958.
- Pompas, R. 2009. Red: from imperial-imperious to popular proletarian. In: *AIC Colour 2009, Proceedings of the 11th Congress of the International Colour Association, Sydney, 28 September – 2 October 2009*, D. Smith, P. Green-Armytage, M. A. Pope, and N. Harkness, eds. Sydney: The Colour Society of Australia.
- . 2009a. Nero, bianco e rosso. *Colore*, July-September 2009.
- . 2017. Rosso sangue in arte: dal cinabro alla luce. In: *Colore e colorimetria. Contributi multidisciplinari*, vol. XIIIAX. Conferenza Nazionale del Gruppo del Colore Italiano, Napoli 2017.
- . 2018. Introduzione al colore: Storia del rosso. *About Umbria* 1 (1).
- Wincler, H. 1992. *La cultura spirituale di Babilonia*. Milan: Rizzoli.

## ***Dulce de leche* as part of the gastronomic landscape of Río de la Plata**

**Lorena Pepa<sup>a</sup>, Analía Rodríguez<sup>b</sup>, Cristina dos Santos<sup>a</sup>, Guillermo Hough<sup>c</sup>, Luis Panizzolo<sup>b</sup>, Pilar Buera<sup>ad\*</sup>**

<sup>a</sup> Universidad de Buenos Aires, Facultad de Ciencias Exactas y Naturales, Buenos Aires, Argentina

<sup>b</sup> Universidad de la República, Facultad de Química, Montevideo, Uruguay

<sup>c</sup> Depto. de Evaluación Sensorial, Inst. Superior de Enseñanza en Tecnología de Alimentos, 9 de Julio, Argentina

<sup>d</sup> Instituto de Tecnología de Alimentos y Procesos Químicos (ITAPROQ-CONICET)

\* pilar.buera@gmail.com

### **ABSTRACT**

*Dulce de leche* is a typical dairy confectionery product and is part of the gastronomic landscape in many South American regions. Although there are discrepancies on its exact geographical origin, and many stories regarding its creation, the most frequent references on its spread and wide consumption are particularly set in Río de la Plata region, shared by Argentina and Uruguay. The shop windows of food stores, bakeries and bars are thus influenced by the color of this typical sweet delicacy.

When people are far from home, the finding of familiar gastronomic products like *dulce de leche*, make them feel in a more accustomed environment. That is why, in late years, migration currents and globalization have made the commercialization of the many variants of this dairy product increasingly popular in faraway countries.

Sensory characteristics of these products are crucial to define consumer acceptability: especially flavor and visual appearance (gloss, visual texture, color, transparency) are considered as determinant criteria for the decision of consumption or rejection.

Even though the formulation is simple, different industrial and home-made procedures are employed, which results in very different sensory outcomes. Also, in different countries and at different times color preferences of *dulce de leche* continually change (more or less solid, clearer, darker, glossy or matte).

In *dulce de leche* preparation, mixtures of milk and sugars (mostly sucrose, with or without other sugars, such as fructose or glucose) are concentrated by the action of heat at normal or reduced pressure at mildly alkaline medium. Maillard reaction (non-enzymatic browning) is responsible for sensory changes, mainly browning and flavor generation. Changes in sugar composition or alkalinity bring about drastic sensory changes.

In present work, the chromatic displacement of *dulce de leche* with different formulations during product preparation stages has been characterized. Several commercial samples from Uruguay and

Argentina, with other samples of *arequipe* and *manjar* from Colombia were included in the CIE chromatic diagram for comparative purposes.

During *dulce de leche* preparation the samples show a color displacement from the achromatic region with very low saturation values, becoming saturated with cooking time through the yellow region up to an intermediate saturation value, and finally deviating with an increased dominant wavelength in the red region in the more saturated samples.

The commercial *dulce de leche* samples from Río de la Plata region were located in the chromatic zone between the intermediate yellow saturation area and the more saturated, “reddish” zones, with a wide variation range. However, the range was even wider when samples from Colombia and other preparations of caramel jam from other geographic zones were added. *Arequipe* and *manjar* were found to be located closer to the achromatic area, while other preparations of caramel jam were dark brown.

Typical customary food preparations, indicating the wide chromatic range of *dulce de leche* and its influence in the urban landscapes of Río de la Plata region, are also presented in this work.

**Keywords:** dulce de leche, browning, chromatic displacement, gastronomic landscape, Río de la Plata



Typical dulce de leche shades

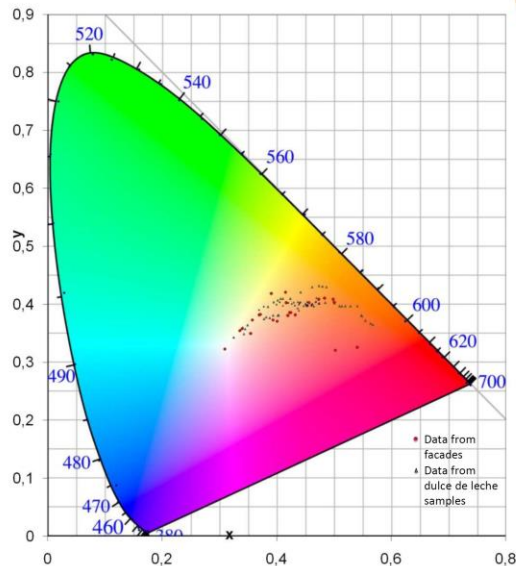

### Urban shops selling dulce de leche

#### Buenos Aires City, Argentina





## Stores at countrysides

### Punta Ballenas, Uruguay



### Florida, Uruguay



The fronts of stores dedicated to dulce de leche are influenced by the color of this typical confectionary.

In urban locations reddish hues and in the countryside yellowish colorations usually accompany brown colorations.

Gourmet stores prefer dark brown and black combinations.

### Province of Buenos Aires, Argentina



San Antonio de Areco

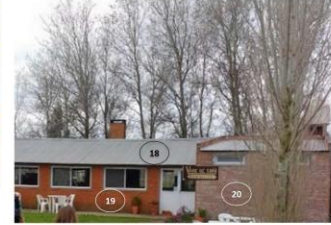

Uribelarrea



Vicente López



González Chaves



Mar del Plata



Tandil

## Color identity in South American natural landscapes: herbs, flowers and fruits crops

**Julieta Gabilondo<sup>a</sup>, Lorena Pepa<sup>bc</sup>, Aldo Fernández-Varela<sup>d</sup>, Nicolás Villagrán dos Santos<sup>b</sup>,  
Lucía Talevi<sup>e</sup>, Fabiano Freire-Costa<sup>f</sup>, Analía Rodríguez<sup>g</sup>, Cristina dos Santos<sup>b</sup>,  
Verónica Busch<sup>b</sup>, Abel Farroni<sup>h</sup>, Luis Panizzolo<sup>g</sup>, César Cortés<sup>d</sup>, Pilar Buera<sup>bc\*</sup>**

<sup>a</sup> Instituto Nacional de Tecnología Agropecuaria, Estación Experimental San Pedro, San Pedro, Argentina

<sup>b</sup> Universidad de Buenos Aires, Fac. Cs. Exactas y Naturales, Deptos Industrias, Química Orgánica y Matemáticas

<sup>c</sup> Instituto de Tecnología de Alimentos y Procesos Químicos (ITAPROQ-CONICET), Argentina

<sup>d</sup> Univ. Popular del César y Fundación para la Ciencia y la Agroindustria Tropical Tropilología, Valledupar, Colombia

<sup>e</sup> Designer

<sup>f</sup> Universidade Federal de Juiz de Fora, Depto. de Ciências Farmacêuticas, Fac. de Farmácia, Minas Gerais, Brazil

<sup>g</sup> Universidad de la República, Facultad de Química, Montevideo, Uruguay

<sup>h</sup> Estación Experimental Agropecuaria Pergamino, Inst. Nac. Tecnología Agropecuaria, Pergamino, Argentina

\* pilar.buera@gmail.com

### ABSTRACT

Natural landscape is associated to national identity. Particularly, local flora expresses national differences and diversity through a number of sensory characteristics. For example, national flowers are symbols representing a country, that may have cultural or religious roots.

Depiction of color landscapes may be related to the naturalization of the region, which gives primacy to nature and is typically found in countries which have been former colonies, such as South American countries. Sensory experiences interact with memory and values to create a specific regional uniqueness generating an intimate alliance among individuals of different countries. Thus, in this region, borders of each country become diffuse and a regional identity is historically established.

Among sensory experiences, color perception is the first contact of individuals with the landscape, eliciting emotions and memories. As such, color characterization offers the possibility to approach the assessment of this regional identity. Therefore, this work is an outcome of a CYTED network composed by members of eight Iberoamerican countries. This network focused in the effective valorization of unexplored plant sources of bioactive compounds for food, medical and cosmetic applications and in spreading their advantages in several workshops and seminars. The meetings were held at several different locations. During these meetings the different natural and cultural resources prompted the attention of participants and the idea of sharing photographs sprang up.

Inspired by the AIC meeting call, color characterization of local *flora* peculiarities became appealing. However, this characterization is only possible if a rigorous color standardization methodology is developed, such as evaluating the color reproduction of the imaging system and calibration of digital cameras.

For the purpose of this work several plant materials considered of special value, have been selected in different countries of the network. After agreeing upon the common reference charts to be included in each picture, photographs were taken. Image analysis was performed with Adobe Photoshop and Image J software. A calibration with a Minolta photocolormeter has been performed employing the reference charts. The chromatic coordinates have been thus obtained. The color characteristics were evaluated through all seasons, from January to September, and throughout several South American regions, and located in a chromaticity diagram.

Preliminary results indicate that image analysis techniques are innovative and helpful tools to portray different landscapes thus depicting regional integration, particular idiosyncrasies and common features.

This work displays the relevance of multidisciplinary and multicultural networks which enable a shared vision and multiple and unexpected outcomes.

**Keywords:** *flora, South America, color, natural landscape*

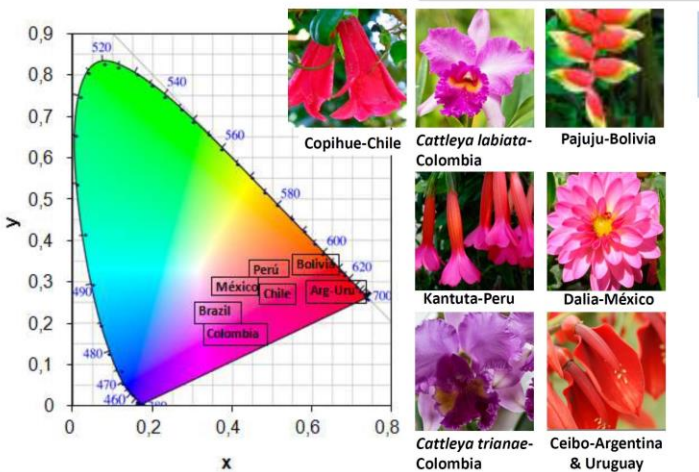
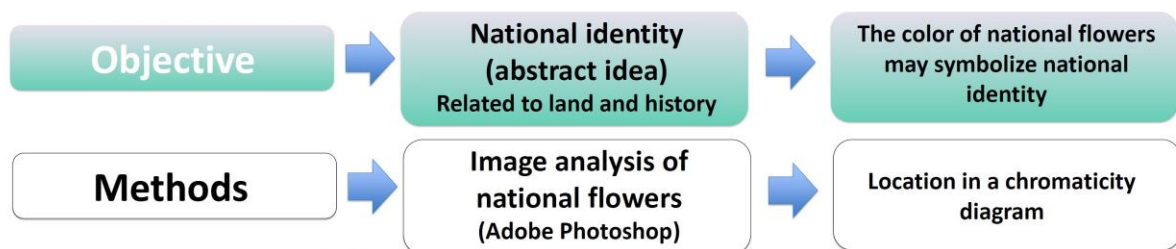

In Ibero-american countries the homogeneous shades illustrate a common social and cultural background. Shades of red allude to colonial times and a struggle for independence. Borders of each country become diffuse and a regional identity is historically established.

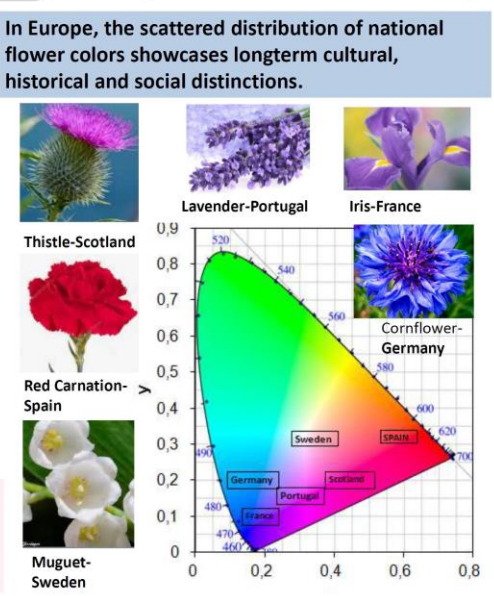

In Europe, the scattered distribution of national flower colors showcases longterm cultural, historical and social distinctions.

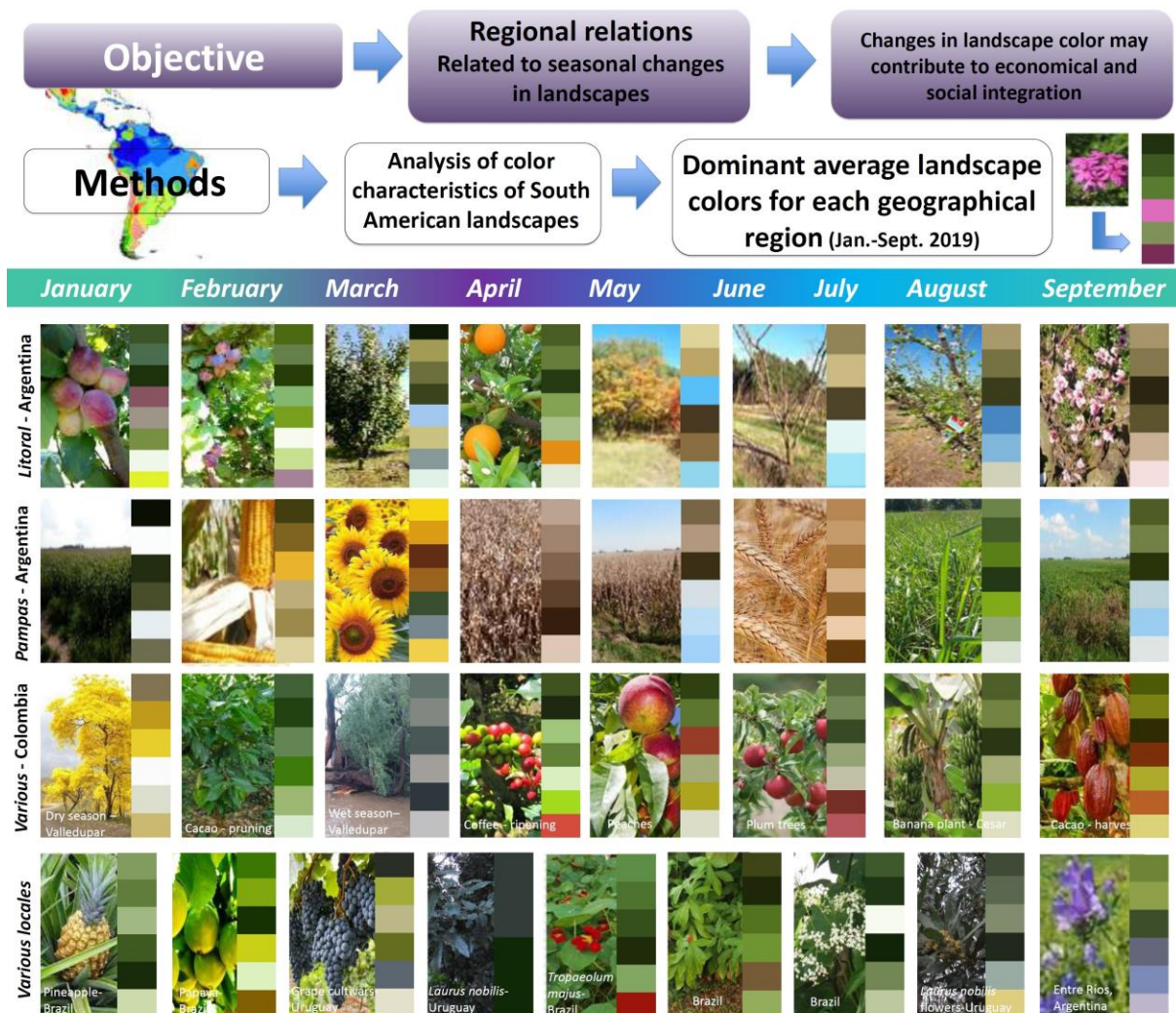

# Colour and art shaping contemporary landscape dimensions

**Verónica Conte**

Universidade de Lisboa, Faculdade de Arquitectura, CIAUD, Lisbon, Portugal  
conte.veronica@gmail.com

## **ABSTRACT**

The paper herein highlights emerging issues mainly resulting from last century's societal changes and technological and scientific advances, which enlarge our understanding of landscape and its dimensions. Through a visual essay based on *expanded* artworks, the nature of Nature we see is questioned. The symbolic discourse used has colour as an important element of its message, along with statements to carefully consider. Attention is drawn to the susceptibility of territories, to human vulnerabilities and to the landscape itself, to fear of loss of the sense of landscape and the search for it in banal or city places. In a global world, where human action has unclear boundaries, is the colour of Nature still green? Facing the issues raised, we seek meanings and new ways of being as well as being in and caring for the landscape.

**Keywords:** *colour, art, landscape, nature, human culture*

## **THEORETICAL INTERLUDE**

Landscape is a term from the late 15th century, used in painting to refer to the representations which have natural scenery as primary subject matter. Since the 16th century, it has been defined as "all land that the eye can grasp" (Rey 1992). The artist Fernando Calhau (2002) observes two implicit elements in this word's first (and common) sense: the observer and the object looked at from a distance, and highlights what happens when we make a "canvas translation". By doing so, a space between both is defined, as well as the possibility of a path to be followed and its resultant memory.

By assigning space, time and memory dimensions to the landscape's experience, it differs now from that enunciated and represented by painting in the 16th century. Its aesthetic components, such as sea, mountains, sky, fauna, flora, colours, or human constructions, in relation *to a certain idea of nature*, remain, but we see it differently. It should be noted that ecological evolution has removed the landscape from its aesthetic function (Carchia and D'Angelo 1999), bringing it closer to biology, as a living system: landscape mosaics. Later the awareness of landscape's living components' vulnerability, some of them dependent on human systems, made culture emerge as a key element for preservation of landscape itself, transforming it into the arena for human culture and identities.

The issues brought forth by the contemporary landscape's dimensions, highlighted by art, put in question the nature of the Nature we see, which part of it we will still be technically able to control, which territories we will have political freedom to inhabit, and in which ways we will contribute to its shape. Thinking about the unprecedented transformation of landscape we witnessed last century, through exploration of resources along with biological and technological research, we are now more alert than ever to observe that the romantic nature painted in Casper David Friedrich's canvas, was the result of a human construction, as much as he was shaping a landscape experience.

This visual essay, based on artworks or their representations, aims to increase critical awareness of landscape's complexity and dimensions as well as opening possibilities for interrelation in its experience. After a bibliographic review in the field of colour, art (installation, site specific, performance, bio art) and landscape; and by analysing colour's effects as physical and symbolic media, the artworks were chosen, not because they represent landscapes or had colour as their main subject, but because of colour's role in shaping the message we want to highlight.

### **BETWEEN NATURE AND TECHNOLOGY, WHAT LANDSCAPE?**

To think: "If Georg Simmel had to show how landscape separated itself from nature [distinguishing landscape as a part of nature, and nature as a whole], now, at the beginning of the 21st century, it is about thinking which nature integrates the landscapes: how to recognize the natural under successive artificializations?" (Serrão 2011: 32). And yet, in the face of technical evolution what positions should be taken, what do they mean and what are the possibilities and limits of action?

*Terraced rice field art project Kassel* (Sakarín Krue-On, 2007, Kassel, Germany, in the Hillside beneath Schloss Wilhelmshöhe). The work, by trying to recreate a cultural landscape of Thailand, (artist's country of origin) that became a green rice field on an unsuitable ground for such

leads to such a perspectivisation: stately architecture of a Western European provenance, as a museum now the place of historical art objects, encounters the millennia old practice of wet rice cultivation, the epitome of the domestication and cultivation of nature with the goal of increasing the yield. In their ways, both function as places of nutrition and storage with the task of generating and preserving physical and intellectual sustenance. "Naturalia" are "artefacts" – what is the backdrop for what? (Marte 2007: 274)

*Asphalt rundown* (Robert Smithson, 1969, Matera, Italy) was an installation of a lorry dumping a load of asphalt under the inert yellow monochrome of an open pit mine, in whose foreground grew sparse and stunted green weeds. The controversial work (by a pioneer artist in the expansion of the field of art to landscape, *Landart*) raises the ambiguity of the destructive and conservationist gestures of the human being. What can be seen as a protest against the continuous construction of the asphalted surfaces that drastically change the landscapes (either physically or through the links and access they provide) is also a symbol of the destruction of life at the deposit site. Desolate violence in an already violated landscape alerts us to the earth as a space unit, as an ecosystem from which nothing can escape, nor what we want to reject or throw away. It enunciates a new landscape involvement, where man is a builder and his element.

Eduardo Kac, one year after the creation of *Alba*, *GFP* (green fluorescent protein) *Bunny*, the albino transgenic rabbit, which when illuminated with blue light (maximum excitation at 488 nm) glowed with a brilliant green light (maximum emission of 509 nm), made *The Eighth Day* (2001, in

collaboration with the Institute for Studies in the Arts, Arizona State University, Tempe). In this bio-art work, Kac “co-creates with nature” a micro ecosystem: “while fluorescent creatures are being developed in isolation in laboratories, seen collectively they form the nucleus of a new and emerging synthetic bioluminescent system. The piece brings together living transgenic life forms and a biological robot (*biobot*) in an environment housed under a clear 4 foot diameter Plexiglas dome, thus making visible what it would be like if these creatures in fact co-existed in the world at large” (Kac 2001). In the West the association of green with Nature goes back to romanticism (Pastoureau and Simonnet 2005). Now *The Eighth Day* and *Alba* through their fluorescent greens, challenge us to think about the malleability of the concept of species and its implications after the slow process of selection-based agriculture, domestication and breeding. They awaken us to the ethics and limits of technological evolution, and make us wonder at the emergence of landscapes with chimerical animals, new times and rhythms of life governed by hitherto unimagined biological responses. And what is our position in these new places? Is green still the colour of nature?

### BETWEEN LOCAL GEOGRAPHIES AND GLOBAL TENSIONS, WHAT LANDSCAPE?

To think: “Just as none of us is outside or beyond geography, none of us is completely free from the struggle over geography” (Edward Said, in Dean and Millar 2005: 122). While it is true that human culture was both shaped by and shaped landscape by seeking stable ways of exploiting resources and applying meanings to it (thus ensuring their survival for centuries), today many landscapes and their builders are vulnerable; there is a tension between local geography and market dynamics inseparable from global pressures. In this new tension, where man and landscape seem to be unprecedented, in the same line of rupture, who shapes what?



Figure 1: *Memorial project Nha Trang, Vietnam: Towards the complex - For the courageous, the curious, and the cowards* by Jun Nguyen-Hatsushiba, 2001 (Dean and Millar 2005: 123, 124).

*Memorial project Nha Trang, Vietnam: Towards the complex - For the courageous, the curious, and the cowards* (Jun Nguyen-Hatsushiba, 2001) offers captivating blue images of local fishermen pulling rickshaws underwater (on the southeast coast of Vietnam). Images represent fluidity and suffocating

pressures that characterized the complex conditions of the country, which was undergoing rapid social and economic development, and where traditional professions were increasingly disenfranchised. The bottom of the sea and the very people upon whom change falls as a problem, form the symbolic scenario of the constraints of the out-of-water landscape, although in question, it is absent in this representation.



Figure 2: *To raise the water level in a fishpond* by Zhang Huan, 1997, outskirts of Beijing (Hoffmann and Jonas 2005: 99).

Figure 3: *When faith moves mountains* by Francis Alÿs in collaboration with Cuauhtémoc Medina and Rafael Ortega, Lima 2002 (Dean and Millar: 151).

*To raise the water level in a fishpond* (Zhang Huan, 1997): The muddy colours of water, which in some records approximate those of a fishpond on the outskirts of Beijing, in which approximately forty recent migrants (invited workers, fishermen, and labourers) stood, made up a scenario, or a still life, which aimed to show that raising the water level by a metre by using lower-class workers was an unsuccessful action. In an extremely symbolic way (in the Chinese tradition, fish is the symbol of sexuality while water is the source of life) this work “was a response to the incredible rural exodus that China experienced in the 1990s, and its consequences” (Hoffmann and Jonas 2005: 98).

*When faith moves mountains* (Francis Alÿs in collaboration with Cuauhtémoc Medina and Rafael Ortega, 2002) was a one-day performance in the Ventanilla (enormous sand dunes, where shanty towns were built by displaced people after the civil war and consequent unstable political situation in Lima, Peru).

500 volunteers were given a shovel [note a tool used to farm] and formed a single [white] line at a foot of a giant [yellow] dune; the group pushed the sand and this sixteen-hundred-foot-long sand dune moved about four inches from its original position. (...) It may have only been by a small amount – although it may have taken years for such a movement to occur naturally – but it was far enough for it to have entered into local history and the mythology of the place. «*When Faith Moves Mountains* attempts to translate social tensions into narratives that in turn intervene in the imaginary landscape of a place. (Francis Alÿs, in Dean and Millar 2005: 150)



## BETWEEN BANAL AND INTIMATE PLACES, WHAT LANDSCAPE?

To think: “The landscapes are multiple, just as distant and immense with perspectives to infinity as close and immediate, but no less immense, such as the curved surface of an apple” (Lenclos 1996, in Fernandes 2006: 33). Faced with the unprecedented capacity for movement and exchange of goods and services on a global scale, and the dramatic growth of cities, we are symptomatically seeking the conservation of landscapes as a refuge of the uniqueness and cultural identity of places; and, in parallel, increasing the plurality of the meaning of the term landscape. Extending it or emptying it of its meaning? On a scale of proximity or distance, in an exotic place, familiar or grey by indetermination, are there landscape possibilities everywhere? In what new places are we placing the need for contemplation and what does it mean? In what ways do these places and landscape constructions arise?

*Airports* (Peter Fischli and David Weiss, 1987-2006) is a series of images of blue-grey views of airplanes landed on airports mainly at sunrises and sunsets. The colours of the skies, the horizontal dimension of the planes, the feeling of vastness, the inner possibility of displacement and travel (calling the attention to the importance of landscape experience in traveling and, the rise in tourism from it) –these are aesthetic elements which lead us to contemplation and the initial enjoyment of landscape. However, they place, as central object of attention, the banal, the *non-place* (Augé 2009) that is simultaneously a global but routine and familiar place. “As Waters confirms, the viewer (...) has glimpsed a new kind of 1990s beauty, over and above the banality of pop or the exasperation of minimalism into a shockingly tedious, fair-to-middling, nothing-to-write-home-about, new kind of masterpiece” (Dean and Millar 2005: 168).

*What colour has the sky got now?* (Marta Traquino, 2010, Lisbon and Brussels) is an installation / action made with the collaboration of visitors / participants, who Traquino asks to look at and paint the colour of the sky from a window in the city, of which we see only a small portion of sky bounded by building edges.

We look to the sky to answer the question. After all, a routine movement. But identifying the colour of the sky may imply more than just a mere look. (...) In the city, through a window, the perception of the sky’s colour will happen through a creative action. (...) and if a question takes one to a certain place from where the colour of the sky can be seen, will the journey undertaken up to this point, be already a part of that same way of seeing? (Traquino 2012)

While stimulating the observation of one of its fundamental elements, indirectly, Traquino leads us to question the absence of landscape.

The Poro’s poetical actions (2002-2006, Belo Horizonte, MG e Vitória, Brazil) such as *Against slogans and battlecries*, or *Garden* act in large cities characterized by impersonality, individuality, real estate speculation, presence of cultural corridors and “in the city’s everyday life an attention to the art of small things (...) inviting the passerby to admire a sensitive action and review his or her own relation to the city, to the unexpected and to his or her own life” (Campbell and Terça-Nada 2011: 115). These works alert the distracted gaze to the poetic potential contained in detail. We emphasize the unpretentiousness of their acts, the sharing of doing (some downloadable online) and a celebration or search for nature in the city landscape. In Poro’s actions (inversely) the cycles of human temporality impose on their non-living elements-symbols of nature.

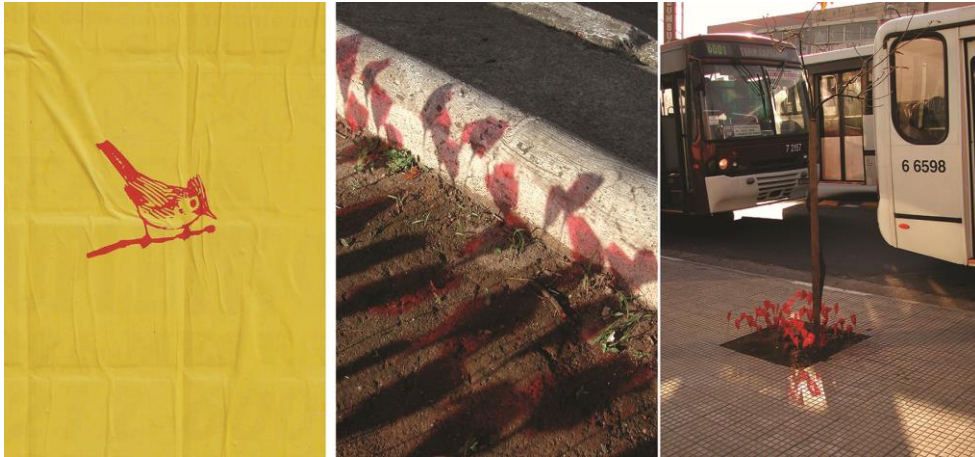

Figure 4: Poro's poetical actions *Against slogans and battlecries* (Poro, 2006, Belo Horizonte, MG e Vitória, Brazil) - series of "lambe-lambe" posters, 100 × 70 cm with screen-printed images of birds posted over street advertising; *Garden* (Poro, 2002, 2004, Brazil) – Instructions: "1 – Make flowers of red cellophane; 2 – Plant them in an abandoned flower-beds in the city" (Campbell and Terça-Nada 2011: 66, 96, 153).

*LiveColour Colourinhabiting* (Verónica Conte, 2012-2015, Montemor-o-Novo, Portugal) is a collaborative action, where residents of a place are invited to change the public space by paintings on their homes' façades. Based on personal objects, relevant to the participants by evoking emotions or aesthetic meaning, the paintings are a method to see and enable to see the people of a place. In the village of S. Cristóvão and historic centre of the city Montemor-o-Novo (taking part in the annual whitewashing ritual and repeating the traditional colours used on the walls) the new paintings brought to light singular (sometimes intimate) thoughts and immaterial aspects of the common heritage. The reference to the elements of nature emerged inseparably from people and landscape, both as memories of agricultural work and as memories of identity. The proposal is open and repeatable, not frozen by musealization, a landscape modelling *with* and *for* the local population (Conte 2019).



Figure 5: *LiveColour Colourinhabiting* (*Vivercor Corabitando*) "Worn by time, happy in the mind" (drawing based on the decoration of small rattles for sheeps); "If you like it smile", "Landscape is what you have the most on earth (J. Saramago)" (Verónica Conte, 2015–2, Montemor-o-Novo and São Cristóvão) (Conte 2019).

## CONCLUSION

Landscape, as in “a colour only exists because we see it. It is but a pure production of man. To meditate”(Pastoureau and Simonnet 2005: 211).

The notion of landscape “allows us to make a reflection on the peculiar relationship between nature and history that takes place in our environmental experience. The notion of landscape makes us see in the environment not only a natural datum, but the result of a complex relationship between the natural element and the human element, which is artificial both on the formation side of the landscape and in its enjoyment” (Gianni and Angelo 1999: 271).

The analysis of the art works cited focused contemporary concerns resultant from the relationship between man and nature: not only the landscape’s ecological vulnerability due to human action, but also human vulnerability itself as part of landscape. In a tension between the morphology of the local landscape and the social policies susceptible to global market dynamics, to which technological advances are added, different landscape dimensions are emphasized: geographical, social and individual. Territory is now a technical product, neither natural nor artificial, and the landscapes “*intermediate* realities between wholeness and uniqueness” (Serrão 2011: 34). Symptomatically, a fear arises of the indistinctness of landscapes, as a transition from the only powerful to the one that can be found anywhere. In response, new ephemeral proposals for attention to *non-places*, grey or banal places, ask citizens to see, think, act, and choose the shape of those places, assuming the interrelationship between who sees, creates, celebrates and takes care of space (Serrão 2011: 34).

The colour —green, blue, yellow, grey, black, white, red— has in these works a dual role. On the one hand (in a reduced number of tones in each work) it emphasizes the real and symbolic dimension of the other aesthetic elements of landscape, such as the gigantic mountain, the oppression of the sea, the horizontality of the airport; or the contrast of the asphalt in the yellow of an open mine, the sky, or colourful poster in the anodyne environment of the city. At every landscape scale, from the mountain to the flower made with paper or painted on the wall, as background or contrast point, colour, not just green, attracts and reveals, converging for itself, the representation of the elements of nature. On the other hand, it is also through colour that images (photographic and video records) acquire a contemplative, meditative charge, bringing us closer to the first landscape experiences. The human figure in the referred works (absent-observer; present-part of; or invited to act-relational) put into perspective the possibility of and increase in awareness about the complexity of the landscape, providing support points for its appreciation and judgment. In a more responsible way, what do we want to be and have in it? In conclusion, bearing in mind the possibility of action on landscape, something which we are all part of, it is essential to quote *Un air rose* (Bernard Lassus 1965) to meditate on the need for ponder, contemplation and sensitivity.



Figure 6:  
*Un air rose* (Bernard Lassus, 1965) (Weilacher 2008: 116).

## ACKNOWLEDGEMENTS

A very special thanks to Catherine Savage for her valuable editorial inputs.

## REFERENCES

- Augé, M. 2009. *Non-places. An introduction to supermodernity*. London: Verso Books.
- Calhau, F. 2002. Sem rede – uma conversa com Fernando Calhau em quatro noites de Fevereiro de 2001. In: *Na paisagem. Coleção da Fundação Serralves*. Porto: Fundação Serralves.
- Campbell, B., and M. Terça-Nada. 2011. *Intervalo respiro pequenos deslocamentos. Acções poéticas do Poro*. Sao Paulo: Radical Livros.
- Carchia, G., and P. D'Angelo, eds. 1999. Paisagem. In: *Dicionário de estética*. Lisbon: Edições 70.
- Conte, V. 2019. *A cor em acção*. Lisbon: By the Book.
- Dean, T., and J. Millar. 2005. *Place*. London: Artworks, Thames & Hudson.
- Fernandes, M. 2006. *A cor na paisagem*. Lisbon: Faculdade de Arquitectura, Universidade de Lisboa, master thesis. Online: [https://www.repository.utl.pt/bitstream/10400.5/5648/1/Tese\\_Veronica\\_Conte.pdf](https://www.repository.utl.pt/bitstream/10400.5/5648/1/Tese_Veronica_Conte.pdf). Accessed: August 2019.
- Hoffmann, J., and J. Jonas. 2005. *Perform*. London: Thames & Hudson.
- Kac, E. 2001. The eighth day, a transgenic artwork. Online: <https://www.ekac.org/8thday.html>. Accessed: August 2019.
- Marte, I., ed. 2007. *Documenta Kassel 16/06 – 23/09 2007. Documenta 12 Katalog | Catalogue*. Cologne: Taschen.
- Pastoureau, M., and D. Simonnet. 2005. *Le petit livre des couleurs*. Paris: Éditions Points.
- Rey, A., ed. 1992. Paysage. In: *Dictionnaire historique de la langue française*. Paris: Dictionnaires Le Robert.
- Serrão, A., ed. 2011. *Filosofia da paisagem. Uma antologia*. Lisbon: Centro de Filosofia da Universidade de Lisboa.
- Traquino, M. 2012. *Ser na cidade – Urbanidade e prática artística, percepções e acções*. Lisbon: Faculdade de Belas Artes Universidade de Lisboa, doctoral thesis. Online: <http://hdl.handle.net/10451/7556>. Accessed: August 2019.
- Weilacher, U. 2008. *Syntax of landscape: The landscape architecture of Peter Latz and partners*. Berlin: Birkhauser.

# Decision of validness in custom color names of JIS Z 8102: case of Japanese color names

**Yosuke Yoshizawa**

National Institute of Technology, Kisarazu College, Japan  
yoshizawa@j.kisarazu.ac.jp

## ABSTRACT

This paper is about a trial to decide valid color names from 145 Japanese custom color names in JIS Z 8102.<sup>1</sup> In Japan, we use “systematic” and “custom” color names in daily communication. Especially, various custom color names have quite different origins —for example, plants, materials, food, regional names, and so on. But it was not revealed whether each custom color name is valid or not for use. To decide valid color names, 53 subjects performed a color choice task, and a color name cluster was constructed from the results of the task in each name. Based on the cluster and Berlin and Kay’s 11 basic color terms, 32 color names were decided as valid.

**Keywords:** *Japanese custom color name, color name cluster, degree of recognition*

## INTRODUCTION

Generally, color names tend to be used for daily communication in color. In Japan, “systematic” and “custom” color names are used based on JIS Z 8102. Custom color names have origin in plants, materials, food, regional names, etc. But it was not revealed whether each custom color name is used accurately or not.

To clarify this question, 3 indices —“Color distance between a given standard color of JIS Z 8102 and the subject’s choice for it in CIE L\*a\*b\*”, “Familiarity of color name” and “Imaginableness of color name”— were acquired from a color choice experiment and questionnaires to subjects, and these indices lead to two new parameters —“Degree of recognition” and “Distance in color space”— in each color name, for the decision of how much recognition exist in each custom color name (Yoshizawa et al. 2009, 2009b).

Using these parameters, the distinction between custom color names that included basic color terms —for example, Chinese red, Chartreuse green, Cobalt blue, and so on— was clarified, and valid color names were decided in each group which included basic color terms based on Berlin and Kay

---

<sup>1</sup> JIS: Japan Industrial Standard.

(1969) 11 color words (Yoshizawa et al. 2009a). In another aspect, the validness of each of the 122 foreign color names was revealed by means of cluster analysis (Yoshizawa 2015).

The aim of this research is to reveal valid names in the rest of 145 Japanese custom color names of JIS Z 8102. First, cluster analysis yields some color name clusters from the data of the color choice task in each of the 145 names. Finally, a representational color is decided based on Berlin and Kay's 11 basic color terms and the color difference between a given standard color of JIS Z 8102 and the subject's choice for it in CIE  $L^*a^*b^*$  in each cluster, and the validness of each custom color can be assessed.

## METHOD

### Color matching task

Each subject was given the task of matching color names with the respective color chip. Figure 1 shows a related tool. The subjects read a custom color name written on a card and chose a color from 468 color chips. In case they could not match a color with its name, they had to choose a color chip.

Custom Color Chart and PCCS 201-L<sup>2</sup> were used as color chips, and 468 colors were attached on the board. White fluorescent lights (FLR 40-S-W/M-x36, by Panasonic, Japan) were used as the source of light and were adjusted at 500 lx on the color chips.

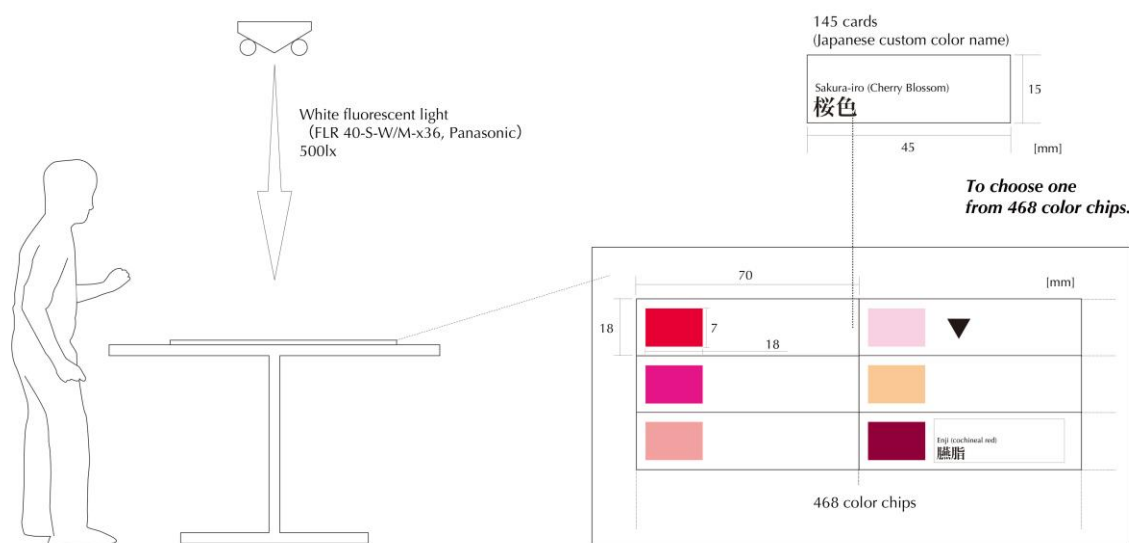

Figure 1: Image of color choice task.

### Subjects

53 Japanese college students participated in this test (31 men and 22 women in the age range of 19-28 years). 72.2% of all subjects belonged to the design section in Chiba University. However, they had little opportunity to study about color names in detail.

<sup>2</sup> Custom Color Chart and PCCS 201-L are both color chart and published by Japan Color Enterprise Co. Ltd.

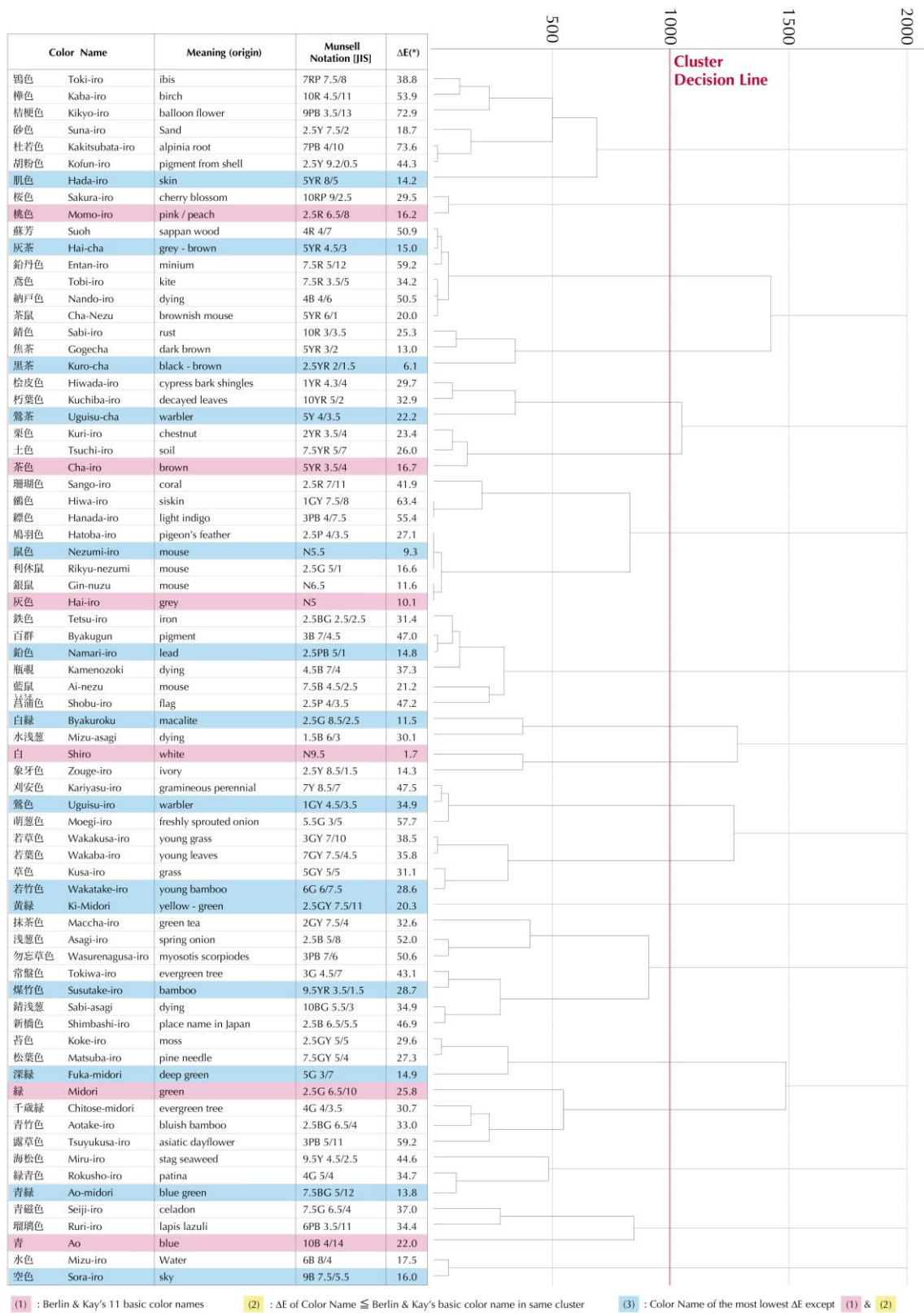

Figure 2: Color name cluster from the color matching task (#1).

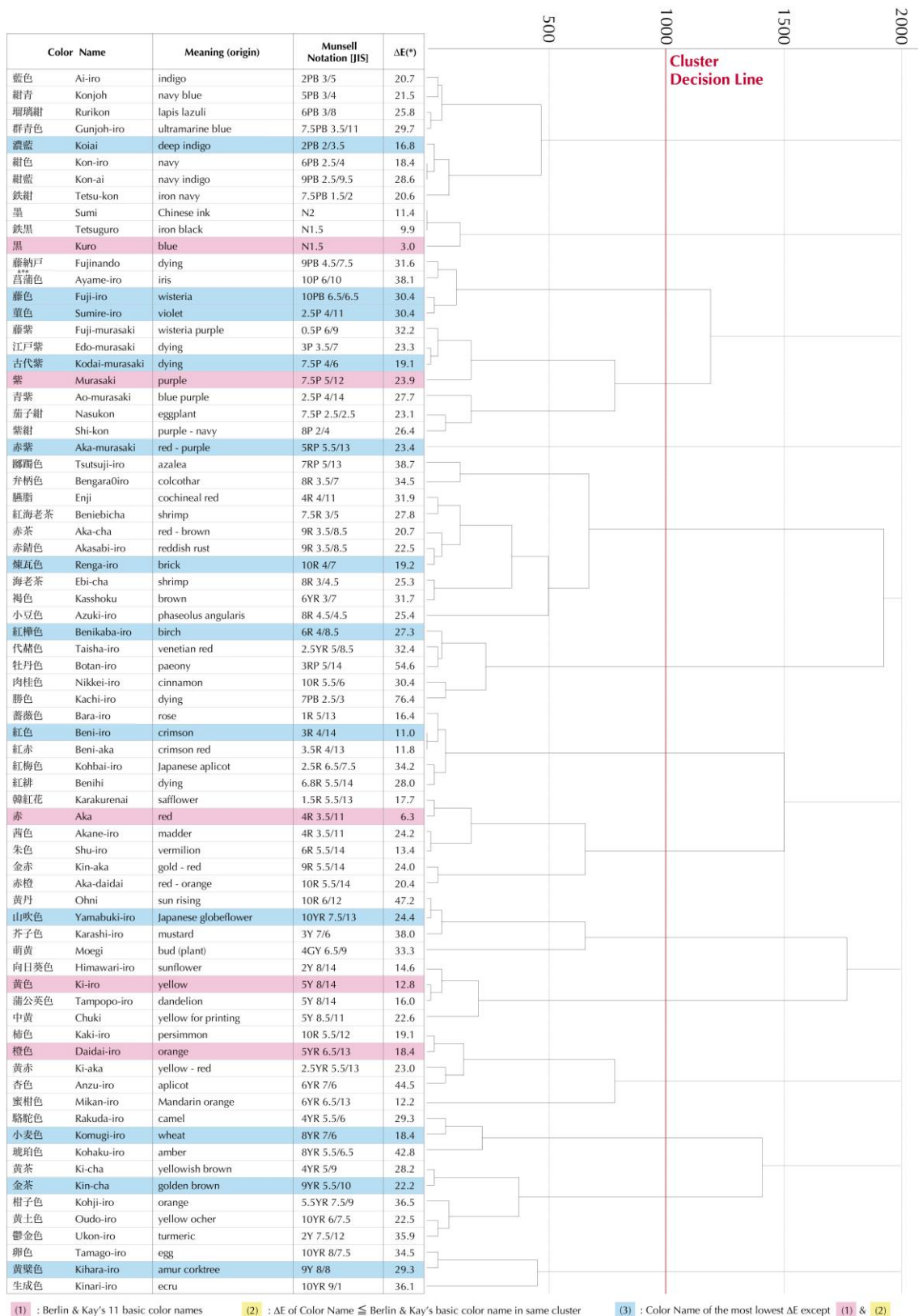

Figure 3: Color name cluster from the color matching task (#2).



## RESULTS

### Cluster analysis

In each color chart, the parameters  $L^*$ ,  $a^*$  and  $b^*$  of CIELAB was acquired with i1.<sup>3</sup> The averages of  $L^*$ ,  $a^*$  and  $b^*$  in each color were used for constructing clusters with the Ward method. The average values of the color distance ( $\Delta E$ ) between a given standard color of JIS Z 8102 and the subject's choice for it in CIE  $L^*a^*b^*$  in each color name are shown in Figures 2 and 3.

### Decision of representative color names

To decide valid color names from the cluster, three regulations were considered:

- 1) To follow Berlin and Kay's basic color terms (pink marks in Figures 2 and 3).
- 2)  $\Delta E$  of color name is less than Berlin and Kay's basic color term in same cluster (yellow marks in Figures 2 and 3).
- 3) To decide the lowest color name as a representative color in each cluster except (1) and (2) (light-blue marks in Figures 2 and 3).

Based on these regulations, the cluster decision line was drawn and 32 valid colors were decided.

## CONCLUSION

In this paper, in order to decide valid custom color names in the JIS, clusters were formed by indices  $L^*$ ,  $a^*$  and  $b^*$  from a color choice task in each of the 145 Japanese custom color names.

Berlin and Kay's 11 color terms and color distances ( $\Delta E$ ) were applied for the decision. In the future, it will be necessary to combine Japanese and foreign clusters and to clarify the significance with ANOVA in each cluster. In another case, even if a name's color distance ( $\Delta E$ ) is low, it is difficult to decide to recognize and use accurately. Based on them, clarification in the use of custom color names will focus on increasing custom color names used correctly and usably.

## REFERENCES

- Berlin, B., and P. Kay. 1969. *Basic color terms; their universality and evolution*. Berkeley, CA: University of California Press.
- Yoshizawa, Y. 2015. Decision of validness in custom color name of JIS Z 8102. In: *AIC 2015 Tokyo, "Color and Image", Midterm Meeting of the International Colour Association, Proceedings*, Tokyo, 19-22 May 2015, H. Yaguchi, K. Okajima, T. Ishida, K. Araki, M. Doi, and Y. Manabe, eds. Tokyo: Color Science Association of Japan, 1153-1157.
- Yoshizawa, Y., et al. 2009. Recognition of custom color name #1: Relationship between distance in color space, familiarity of color names and imaginableness of color names. And trial of determination in recognition. *Journal of the Color Science Association of Japan* 33 (2): 96-107.
- . 2009a. Research on the recognition of custom color names: #2 Distinguishment and basic color tendency of custom color names in color choice task. *Journal of the Color Science Association of Japan* 33 (3): 218-229.
- . 2009b. Recognition of non-Japanese custom color names: Relation among distance in color space, familiarity of color names, and imaginableness of color names. In: *International Association of Societies of Design Research, IASDR 2009 Proceedings*, CD-ROM.

<sup>3</sup> Color measurement instrument by X-rite Co. Ltd.

# “Color and landscape” in our eyes: collective project 2019 of the Grupo Argentino del Color (GAC)

**María Paula Giglio**

President, GAC  
gac@fadu.uba.ar

## ABSTRACT

As part of the actions for the International Color Day (ICD), established on March 21 by the International Color Association since 2009, the Argentine Color Group (GAC) made an open invitation to participate in the project “Color and landscape in our eyes”, based on the proposal of the ICD 2019 call: “Celebrations of the International Colour Day aim to develop awareness to the importance of colour phenomenon and culture in the broad domains of art and humanities, science, and technology”. This project is based on the intention to recognize ourselves in our diversity through a series of photographs that combine a variety of colors of our eyes, the multiple landscapes that surround us, the plurality of views on those landscapes, and the mixture that is generated in the superposition of the own and reflected colors, through a game between light, observer, surroundings, space, color and cesia. In addition, we sought to address the theme “color and landscape” of the AIC 2019 Meeting in Buenos Aires.

In this presentation, all the photographs received that were uploaded to the GAC page, to a page created for this purpose and to the GAC social networks are exposed. People that have participated in this project, took a picture of one of their *eyes* looking at a *landscape* (natural, artificial, day, night, cultural, social, interior, exterior, designed, urban, symbolic, artistic, technological, ecological, artistic, or virtual landscape, among others), following these specific instructions:

1. Take a picture of your eye looking at a landscape, on March 21 or any other day of autumn in the Southern Hemisphere, or spring in the Northern Hemisphere.
2. Trim the photo so that only the eye is seen, centered on the eyeball, in horizontal format 16:9.
3. Upload the pictures to your social networks with the following hashtags included: #diainternacionaldelcolor2019, #grupoargentinelcolor, #internationalcolorday2019.
4. Send the pictures to [gacdiainternacionaldelcolor@gmail.com](mailto:gacdiainternacionaldelcolor@gmail.com). If possible, indicate the places where the photos were taken.
5. For those interested in continuing to participate in the project, we invite you to take another photo looking at the same *landscape*, on September 21 or any other spring day in the Southern Hemisphere, or autumn in the Northern Hemisphere.

**Keywords:** *landscape, visual appearance, eyes, view, International Color Day (ICD)*



Different landscapes reflected in different eyes.

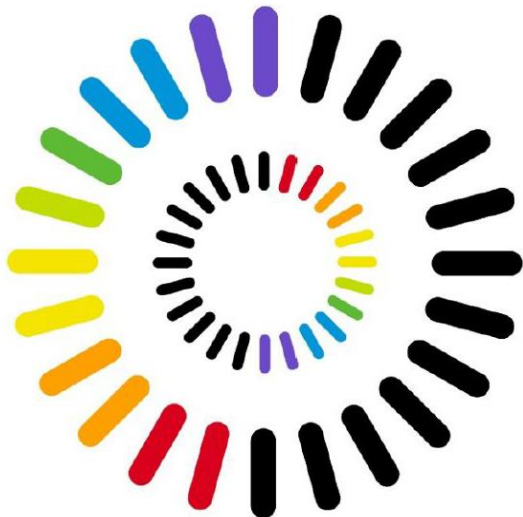

INTERNATIONAL COLOUR DAY  
21 MARCH

ESTABLISHED BY AIC - INTERNATIONAL COLOUR ASSOCIATION

# Light and Color



# Color rendering of window glass: analysis of the occupant's view with hyperspectral imaging

Coralie Cauwerts<sup>a</sup>, Sophie Jost<sup>b\*</sup>

<sup>a</sup> Université catholique de Louvain, Architecture et Climat, Louvain-la-Neuve, Belgium

<sup>b</sup> University of Lyon, ENTPE, LGCB, Vaulx-en-Velin, France

\* sophie.jost@entpe.fr

## ABSTRACT

Window glass can have a strong impact on the color appearance of both the indoor space and the outside view. When specified, color rendering properties of such products are in general indicated by a label —the tint of the glass— and a color fidelity index which is an amended Color Rendering Index where D65 is the reference illuminant. This paper presents an alternative indicator that provides descriptive information about the color content of the occupant's field-of-view, and shows color shifts due to glazing. The paper illustrates the interest of this new indicator for investigating the influence of the content of the view on people's preferences. The impact of three tints of glass on three different scenes extracted from a hyperspectral image database developed by the authors is analyzed. A psychophysical experiment was conducted. It highlights that the most and the least preferred glass vary according to the scene.

**Keywords:** *window glass, outside view, color rendering, hyperspectral imaging, people's preferences*

## INTRODUCTION

The need for energy savings led to an increasing use of emerging technologies in buildings such as high performance windows. While technical data sheets provided by glass manufacturers are usually full of information on thermal insulation and solar heat performance —allowing the architect or the building engineer to find a compromise between luminous transmittance ( $T_{vis}$ ), solar factor ( $g$ ) and heat transfer coefficient ( $U_g$ )— few information are given on how glass affects color of indoor and outdoor environments. When they are specified, color rendering properties of glass products are in general indicated by a label —the tint of the glass— and a color fidelity index which is an amended Color Rendering Index where D65 is the reference illuminant (CRI  $Ra_{D65}$ ), as recommended by EN 410:2011. Regrettably, such indications are not sufficient for predicting people's preferences. Our hypothesis is that the content of the outside view widely influences the level of satisfaction of building occupants regarding the tint of the glass. We think that better understanding color shifts of

natural elements such as the sky and the vegetation as well as mechanisms of satisfaction is necessary to develop good color rendering metrics for window glazing systems. We propose to investigate this using hyperspectral imaging and a graphical indicator we recently developed (Cauwerts and Jost 2018, Jost et al. 2019).

Specifically, this paper will:

- briefly describe the graphical color shift indicator (for details, the reader can refer to the above-mentioned papers);
- promote a database of large field-of-view (FOV) hyperspectral images for building research;
- test the graphical indicator on several tints of glass and kinds of occupant's views.

## GRAPHICAL COLOR SHIFT INDICATOR

The newly developed indicator aims at informing on color content of architectural environments and at showing color shifts due to illuminant or glass changes in an intuitive way. It is in line with representations recently developed in electric lighting to provide information on color rendering. Its originality lies in (1) a contextualization (images are analyzed rather than a set of predefined and flat color samples), (2) a division of the color space based on color naming, and (3) the opportunity to compare scenes with illuminants of different correlated color temperatures.

As input, the indicator requires the CIE tristimulus values (XYZ) of a scene. Such data can be acquired with HDR photography, imaging colorimeter, hyperspectral camera, or produced by (spectral) simulation. An advantage of working with hyperspectral images is the opportunity to simulate the impact of virtual illuminants such as glass and light sources under development. The iCAM06 color appearance model is then applied to the XYZ image in order to predict spatial and color appearance phenomena such as chromatic adaptation, simultaneous contrast, crispening, Hunt effect, Steven effect and Bartelson-Breneman surround effects. In the iCAM06 framework, color appearance attributes are represented in the IPT uniform opponent color space. To facilitate the interpretation of the color content of the scene, we propose to work in the PT plane and to divide it into 18 bins (18 color categories) based on color naming. Color shifts, by bin or by element, are represented by vectors that begin with the mean original PT values (empty symbols) and end at the mean shifted PT values (same pixels analyzed, plain symbols). Two circular histograms, representing the proportion of pixels assigned to each color category, complement the graphic. Last, an indication on gain or loss of contrast (K), local luminance contrast (L), brightness (J) and gamut (G) is given, for the entire scene or, if applicable, for a specific element.<sup>1</sup>

## HYPERSPECTRAL IMAGE DATABASE

Most existing hyperspectral database are mainly outdoor scenes with limited FOV, or pictures of specific objects. Our will is to make available, to the lighting and color communities, a database of high spatial and spectral resolution images with large FOV. The database,<sup>2</sup> in development (14

---

<sup>1</sup> As a first approximation, contrast (K) is computed as the geometric mean of variances of each dimension of the IPT color space. Local luminance contrast (L) is computed as the mean relative difference between the luminance of each pixel to the mean luminance of its eight neighbors. G is calculated during the analysis by bin as the area of the polygon whose vertices are the 18 mean PT values.

<sup>2</sup> Database is available at: <https://www.entpe.fr/ressources-p2e>

images are currently available, see Figure 1), will be composed of natural and man-made built environments as well as typical lab scenes captured in a light booth.

Hyperspectral data currently available in the database were acquired using a VNIR4 SPECIM (sCMOS-50-V10E model) hyperspectral camera attached to a SPECIM rotating scanner (line-scanning system). A 18.5 mm lens (f/2.4 fixed aperture) was mounted on the camera which is equipped with a sCMOS sensor (14.2 mm width, x-y spatial resolution is  $2160 \times 1080$  pixels). The resulting vertical FOV is  $42^\circ$  (the horizontal FOV depends on the rotation of the camera). The camera spectral range is 400-1000 nm. Its spectral resolution FWHM is 2.9 nm (30 microm slit). Spectral sampling varies between 0.63 and 5.07 nm according to the binning. The signal-to-noise ratio (peak) is 170:1 (no binning).

For reducing file size, data were acquired with a 2-by-2 binning resulting in a vertical spatial resolution of 1080 pixels and 480 spectral bands with a width between 1.22 nm (at 394.6 nm) and 1.34 nm (at 1007.00 nm). Dark noise correction and radiometric calibration were done in AizaTools Version 4.3 vs2008 producing two ENVI files: a binary file (.dat), and a header file (.hdr) containing the metadata associated with the binary file. The Matlab multibandread command can then be used to load ENVI files and produce hyperspectral cubes (radiance is in  $\mu\text{W}/\text{cm}^2\cdot\text{sr}$  per nm).

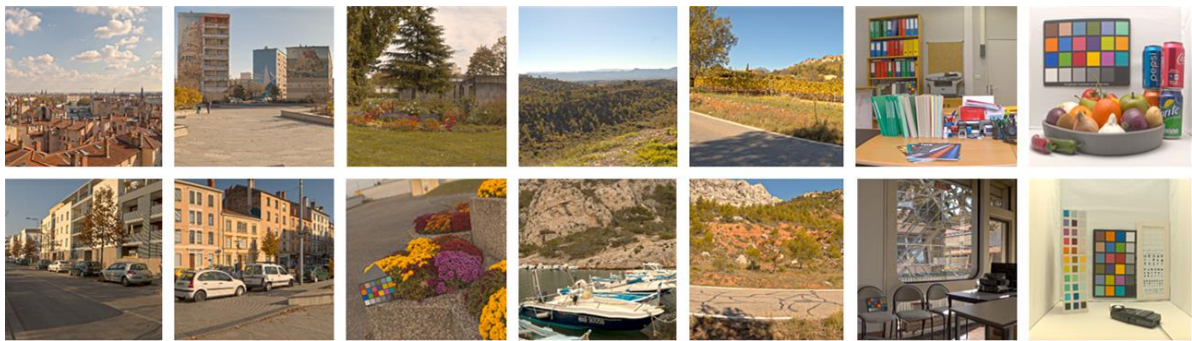

Figure 1: Overview of scenes currently available in our hyperspectral image database.

## APPLICATION

This section illustrates the application of the graphical color shift indicator on three scenes: two outside views from window (available in the database) and a computationally-rendered<sup>3</sup> hyperspectral image mixing both indoor and outdoor contents (Figure 2).



Figure 2: The three studied scenes and the spectral transmittance of the three coated glazing (+ reference).

<sup>3</sup> Scenes were rendered with Ocean 2018 R4.

The three scenes were filtered by three coated glazing that are three variants of a same brand name. Their spectral distributions (Figure 2) were exported from Optics version 6.0 that integrates the International Glazing Database (IGDB). Some visual and thermal characteristics given by the manufacturer and calculated by the authors are presented in Table 1. The National Fenestration Rating Council (NFRC) identification number for retrieving them in IGDB is also given.

NFRC_ID	Tint	CRI-Ra_D65	T_vis	g	Ug	CCT*	Duv*	MCRI*
4285	clear	95	63%	66	5.7	4936K	-0.0032	92
4287	dark blue	85	42%	45	5.7	7216K	0.0030	89
4295	green	93	52%	44	5.7	5371K	0.0058	88

Table 1: Characteristics of glass (the asterisk means that the value was calculated by the authors).

Color shifts due to the glass are presented in Figure 3. Original scenes (empty points and empty histograms) are equipped with an ideal window glass of 100% transmission (called reference in Figure 2). Points and vectors in grey mean that less than 2% of the original scene are in the corresponding color category. Vectors in black are for analysis by element (sky, grass, etc.).

It can be observed that the first scene is mainly composed of blue-purple (the sky), orange and yellow-orange (façades and clouds). In the second scene, the color content analysis method identifies mainly yellow and orange despite the large presence of grass, expected to be green. This was discussed in our previous papers where we highlighted the fact that color appearance models predict visual appearance phenomena but not the influence of the context on the interpretation of the color by the brain. In the third scene, we find the green component of grass, the blue component of sky and a variety of other colors. Concerning color shifts, in the first scene, the dark blue glass is the only glass to increase the chroma of the sky. In the second scene, the overcast sky was originally a slightly saturated orange. The clear glass increases its chroma without modifying its hue making the sky more orange but less contrasted. With the dark blue glass, the sky shifts toward a low saturated blue with a higher contrast. This glass is also the one maximizing the hue shift of the grass toward green, but with a loss of chroma. The green glass also produces a hue shift toward green (to a lesser extent) but with a chroma gain. In the third scene, the color shift tendencies observed on blue sky and green grass are similar than in scenes 1 and 2.

## DISCUSSION

To complement the objective analysis, a preference survey was organized. Six people were asked, for each scene, to rate their preference for the different glass with a pair comparison method. Images were displayed in a dark room on a calibrated EIZO ColorEdge monitor. The comparison of glass was done after a 2-minute adaptation period. The presentation of the scenes was randomized for each subject and pairs of glass were balanced. Paired comparison data were analysed using Dunn Rankin variance stable rank sums (VSRS) (coefficients of consistency are 0.93, 0.87 and 0.80 for scene 1, 2 and 3, respectively). Figure 4 shows that the most preferred (higher value) and the most disliked (lower value) glass varies significantly with the scene, even with few subjects. Consequently, the clear glass which has the highest color fidelity (CRI-Ra\_D65) and the highest MCRI index is not always the preferred one.





Figure 3: Color shifts predicted by the indicator in the three studied scenes for a clear, a dark blue and a green glass (reference is an ideal window glass of 100% transmission).

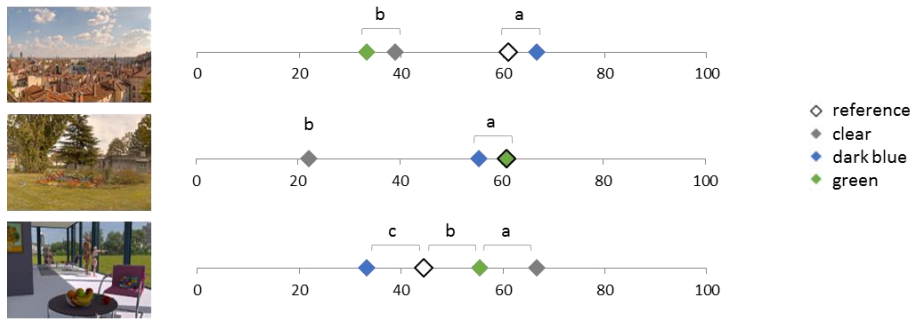

Figure 4: Graph of reward preference scale values. Glass belonging to different groups are significantly different (at 0.05).

Scene 1 which has a large proportion of blue sky was preferred with the dark blue glass (difference with no glass is not significant). This glass is the only one to increase the chroma of the sky, probably rendering it closer to memory representation. Scene 2 which has a large proportion of green grass was significantly less preferred with clear glass, maybe due to the loss of contrast. For scene 3 which contains both blue sky and green grass, the green glass was preferred over dark blue one, but the preferred glass is the clear one.

## CONCLUSION

Pursuing the comparison between people's preferences for glass tint in buildings and objective analysis of color shifts with hyperspectral images seems to be a good way to better understand occupants' satisfaction mechanisms. Until now, in our work, gain or loss of contrast have not been much investigated, it should be considered in further work.

The complexity introduced with the proposed graphical color shift indicator could certainly be reduced in the future when elements involved in preference judgment will be identified and classified by order of importance. However, a visual support would probably always be welcome in design and decision processes. Last, the creation of a spectral database of natural elements (foliage, green grass, blue sky...) is probably a necessary step to better understand color shifts of such elements as well as determining memory colors and ellipsoids of acceptable shifts.

## ACKNOWLEDGEMENTS

This work was partially supported by the Belgian Fund for Scientific Research through the postdoctoral fellowship of C. Cauwerts. The authors thank P. Avouac for help in collecting hyperspectral data.

## REFERENCES

- Cauwerts, C., and S. Jost. 2018. A color graphic informing on the impact of electric lighting and coated glazing in complex architectural scenes. *Color Research and Application* 43: 885-898.
- Jost, S., C. Cauwerts, and T. Poikonen. 2019. A colour graphic for real complex scenes: application to LED illuminants. In: 29th Quadrennial Session of the CIE 2019, Washington DC, 163-171.

# Quantitative condition for making the appearance of fluorence in actual architecture using chromatic light

Mai Minami, Toshiki Torimitsu, Nozomu Yoshizawa\*

Tokyo University of Science, Chiba, Japan

\* yosizawa@rs.noda.tus.ac.jp

## ABSTRACT

Fluorence is a region of the surface mode of colour appearance, defined by R. M. Evans in 1959, which contains no gray and appears to fluoresce. The aim of this research is to reveal a quantitative condition for making the appearance of fluorence in actual architecture. In the experiment, subjects observed the target board through the opening on the background, and the amount of light was increased/decreased stepwise to examine the threshold value where the target appeared to be fluorence. The result showed that, in most cases, luminance values when the target appeared as fluorence coincided with those of the optimal colour. In future works the estimation method of fluorence should be examined in various architecture where the fluorence appears on the plane without openings.

**Keywords:** *mode of colour appearance, fluorence, optimal colour, aperture colour*

## INTRODUCTION

Light, which is an important element in architecture, has a great effect on the appearance of architectural space. Furthermore, light sometimes brings us a special sensory experience. For example, the building in Figure 1 looks as if the illuminated wall dimly shines and the wall surface itself appears to fluoresce. Such an appearance was defined by R. M. Evans as fluorence in the 1950s, and it has been increasing in recent years in various actual architecture as the development of LEDs which can produce high optical colour purity. However, the conditions for making the appearance of fluorence on chromatic surfaces are still vague, and such appearances are sometimes designed only with the instinct and experience of designers. If this expression condition can be quantified, it will contribute to expand the range of lighting design and spatial rendering techniques.

The aim of this research is to reveal a quantitative condition for making the appearance of fluorence in the environment where the object surface is illuminated with chromatic illumination.

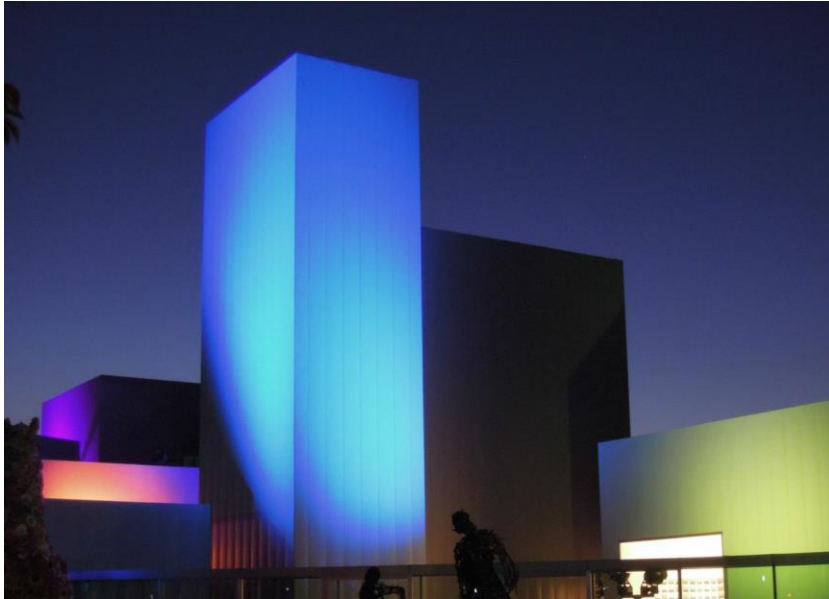

Figure1: The appearance of Fluorence on the walls illuminated with LEDs.

## THEORY

### Definition of fluorence

The mode of appearance of colour defined by D. Katz (1935) did not include the fluorence. Fluorence is a region of the surface mode of colour appearance, defined by R. M. Evans in 1959, which contains no gray and appears to fluoresce.

### Optimal colour

An object surface having a certain chromaticity has the maximum lightness that the surface can take because of the restriction that its spectral reflectance is 1 or less at any wavelength. The colour of the surface having this maximum lightness is called optimal colour. The optimal colour is the lightness limit for realizing the surface of the chromaticity as the object colour. The luminance when the object surface becomes optimal colour can be calculated from the spectral distribution of the illumination light, the chromaticity coordinates  $x$  and  $y$  of the target surface, and the colour matching functions  $\bar{x}$ ,  $\bar{y}$  and  $\bar{z}$ .

In the research of Fukuya et al., it was assumed that the vision system somehow knows the brightness of the optimal colour on the object surface, and by comparing its brightness of the optimal colour and the actual brightness of the object surface, the luminance threshold for transitioning from the surface-colour mode and the illuminant-colour mode is determined. In their subjective experiment, a CRT monitor was used to measure the luminance for mode transition, and this value was compared with the calculated luminance when the object surface was optimal colour. The result of the experiment was that although the measured luminance for mode transition and the calculated luminance of the optimal colour showed a strong correlation, the absolute values of them were different. Although this result alone could not support the hypothesis that the visual system knows the brightness of the optimal colour in some way and determines the transition luminance of the mode, it has been shown that it would be meaningful to refer to this calculation algorithm to find out the method for quantifying the conditions for mode transition from surface mode to fluorence in actual architecture.

## EXPERIMENTS

### The purpose of this experiment

A CRT monitor was used for displaying the target and its background surface in the experiment of Fukuya et al., whereas the purpose of this experiment is to investigate whether or not the luminance for mode transition from surface mode to fluorence on the target surface, which is set up in the actual space and illuminated by chromatic light, can be estimated on the based on the above hypothesis of the optical colour when the target is observed through the aperture in the background.

### Experimental space

Figure 2 shows the experimental space. The wall, ceiling, and floor surfaces were black. The height of subject's viewpoint was 1200 mm on the floor, and the observation point was 1500 mm distant from the background surface.

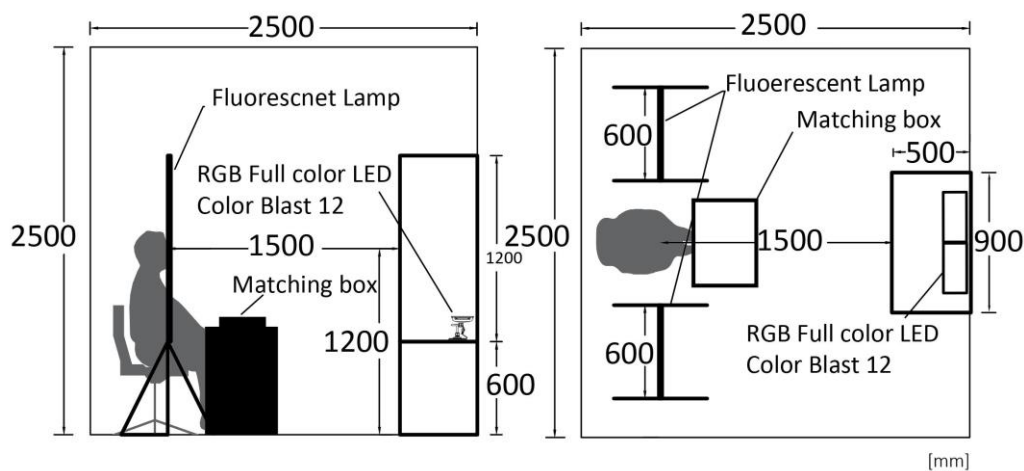

Figure 2: An elevation (Left) and plan (Right) of the experimental space.

### Target and background

The size of the background board was 900 mm × 900 mm, and there were three levels of the lightness: black (N1), gray (N5), and white (N9.5). Styrene boards were painted in N1, N5 and N9.5, respectively, and each back side was covered with a plywood and aluminum foil sheet to prevent light transmission (Figure 3). The target surface was white (N9.5). It was observed through an opening of 265 mm × 265 mm in the center of the background board, and the edge of the opening was cut by 45° to appear sharp.

### Lighting conditions

A 40-inch straight tube fluorescent lamp (5000 K) with high colour rendering was used for ambient lighting, and two lamps were installed vertically behind the subject. In order to illuminate the experimental space uniformly the LEE filter 400 was used, and the output was always constant.

Full-colour LED spotlights (ColorBlast 12 by Color Kinetics) were used to illuminate the target. The uniformity of luminance distribution on the target surface was high, and the ratio of minimum to maximum luminance was 0.955. There were five hues: red [R], green [G], blue [B], yellow [Y] and white [W]. Red, green, blue, and yellow have 26 levels of luminance, and white has 27 levels, and each luminance level was presented to the subject step-by-step in ascending/descending order.

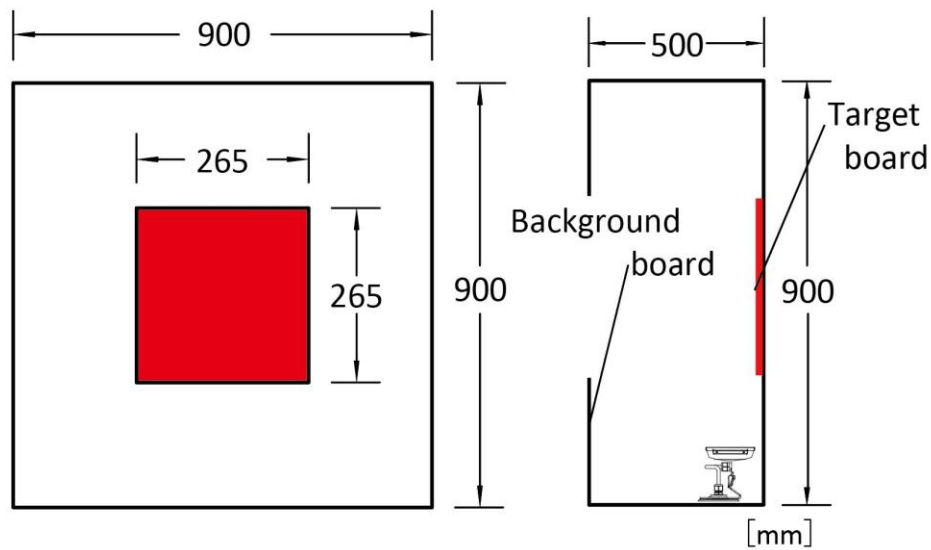

Figure 3: Front view (left) and elevation (right) of the target (red) and background.

### Experimental methods

Subjects were 13 students in their 20s. First, only ambient lighting was turned on and the subject adapted to this light environment for 10 minutes. Next, the mode of colour appearance evaluation were performed at the start of each stimulus presentation series. The mode of colour appearance was evaluated on a 13-point scale from surface colour, fluorence to luminosity. Then, experimenter gradually increased/decreased the intensity of the LED spotlights, and the subject responded when the mode of appearance changed from [surface colour to fluorence] and [fluorence to luminosity], or [luminosity to fluorence] and [fluorence to surface colour]. There were total 15 experimental conditions including 5 hue levels of the target surface and 3 lightness levels of the background surface.

### RESULTS AND DISCUSSION

Table1 shows the average / standard deviation/ 95% confidence interval of the threshold luminance when the subjects perceived the mode of colour appearance of the target as fluorence, and calculated luminance of the optical colour, for each experimental condition. [R-N1] indicates that the hue of the target and the lightness value of the background are Red and N1, respectively. Each threshold luminance was calculated by averaging the both results in ascending and descending orders per subject.

	R-N1	R-N5	R-N9.5	G-N1	G-N5	G-N9.5	B-N1	B-N5	B-N9.5	Y-N1	Y-N5	Y-N9.5	W-N1	W-N5	W-N9.5
Threshold Luminance of fluorence[cd/m <sup>2</sup> ]															
Average	7.44	6.61	8.13	7.49	7.62	11.65	4.01	4.13	4.50	16.50	14.82	23.03	18.91	17.91	25.05
Standard deviation	3.47	2.33	2.33	2.16	2.43	4.72	1.99	1.40	1.12	7.98	7.39	12.79	12.26	15.49	9.88
95% confidence interval	1.89	1.27	1.27	1.18	1.32	2.57	1.08	0.76	0.61	4.34	4.02	6.95	6.66	8.42	5.37
Luminance of optimal colour[cd/m <sup>2</sup> ]	7.39	7.11	8.67	8.91	8.83	12.74	5.23	5.71	6.26	17.55	15.38	24.82	25.04	23.70	33.17

Table1: Threshold luminance of the fluorence and calculated luminance of the optical colour.

Figure 4 shows a graph comparing the measured threshold luminance of the fluorence with the calculated luminance of the optimal colour for each experimental condition. Unlike the results in the research of Fukuya et al., there were no statistically significant differences between the two values, except the experimental conditions of [B-N5], [B-N9.5] and [W-N9.5], therefore, most luminance levels for transition mode from surface mode to fluorence could be estimated from the luminance values of the optimal colour.

In this experiment the target was observed through the opening in the centre of the background, and because of sharp edges of the opening and the uniform appearance of the target, it looked as if the target was separated from the background and appeared to be close to film colour. It could be speculated that, in this experiment, the luminance for mode transition to fluorence could be estimated from the optimal colour luminance, which is not affected by the contrast effect of surroundings, because the target itself was perceived separately from the surroundings.

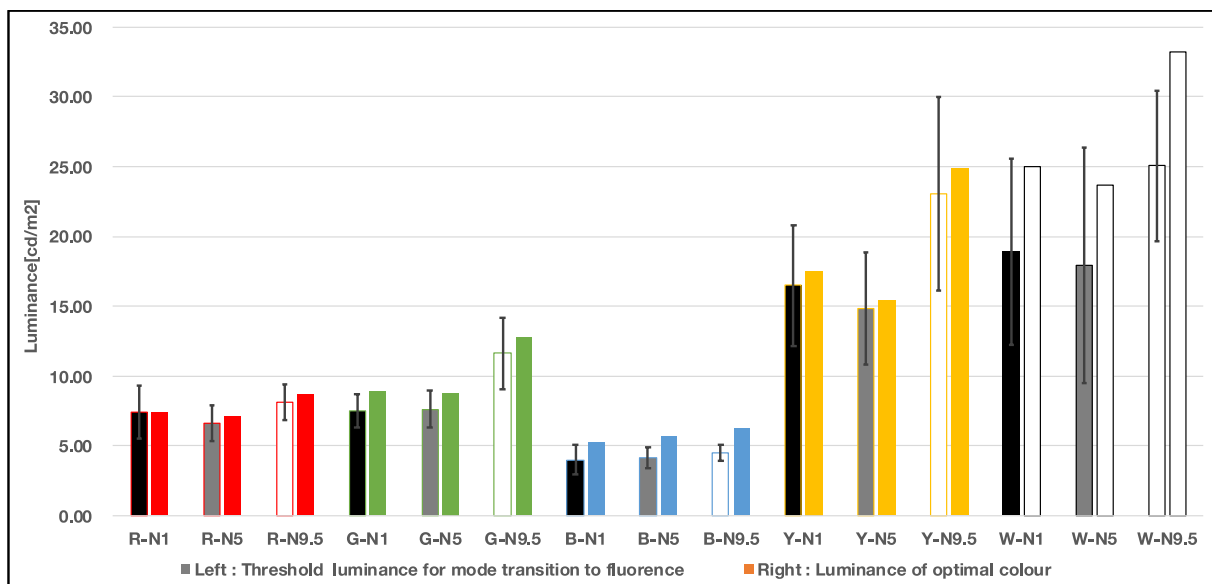

Figure 4: Comparison between the threshold luminance for fluorence and optimal colour luminance.

## CONCLUSION

The results of this research show that the luminance conditions for transiting to fluorence could be estimated from the optimal colour luminance in most cases in actual architecture, when the target is observed through an aperture in the background surface. In the future, it will be necessary to examine the luminance condition for mode transition to fluorence when the target is positioned on the same plane of the background and its appearance is strongly influenced by the surroundings.

## REFERENCES

- Evans, R. M. 1959. Fluorescence and gray content of surface colors. *Journal of the Optical Society of America* 49 (11): 1049-1059.
- Fukuya, T., K. Uchikawa, and Y. Yamauchi. 2008. Similarity between luminance for mode transition and that of the optimal colour for stimuli with different chromaticities (in Japanese). *Vision* 20 (4): 179-186.
- Gilchrist, A. L. 1999. An anchoring theory of lightness perception. *Psychological Review* 106 (4): 795-834.
- Katz, D. 1935. *The world of colour*. London: Kegan Paul, Trench, Trubner & Co.
- MacAdam, D. L. 1935. The theory of the maximum visual efficiency of colored materials. *Journal of the Optical Society of America* 25: 249-252.



# Effects of object colour stimuli on human brain activities and subjective feelings in physical environment and virtual reality

Guobin Xia\*, Phil Henry, Francisco Queiroz, Stephen Westland

University of Leeds, UK

\* sdx@leeds.ac.uk

## ABSTRACT

This work explores the potential of Virtual Reality (VR) as a medium to support emotional positivity and well-being. In this study, we investigate and compare the effects of colour first in a physical test room and then in an identical VR environment. We measured ten participants' physiological responses to different colours of light in both physical and virtual environment with the assistance of an electroencephalogram (EEG) system. We also required all those participants to report on their subjective feelings through a Positive and Negative Affect Schedule (PANAS) questionnaire. In conclusion, our experimental results indicate that human's subjective experience of emotion and brain activity are affected by the coloured-lighting conditions, and the impacts show different trends between red and blue lighting. Furthermore, such impacts in the physical environment can be generally replicated in VR.

**Keywords:** *colour, light, virtual reality, Thouslite LED system, wellbeing*

## 1. INTRODUCTION

Colour and light play important roles in human's vision, but also affect emotion, circadian rhythm, daily behaviour and physical health (Volpe 2016, Lyon et al. 2012, Czeisler et al. 1986, Eastman et al. 1998, Westland et al. 2017). Research evaluating the potential of physiological and behavioural response in built environments is constrained by the cost of full-scale test facilities. This work simultaneously exploits two new flexible technologies, evaluating how the impact of colour and light have the potential to positively impact on engagement and wellbeing (Oh et al. 2014). The ability to create accurate immersive light and colour conditions in a real-world room-set is delivered via the unique Thouslite LED system. The reproduction of that environment in VR provides the opportunity for an original investigation directly comparing human response to colour and light between these two domains. This work further explores the established relationship between the design of coloured-lighting conditions and interior environments. Replicable results in the virtual environment

could add to the argument that VR applications have greater potential to contribute to human wellbeing (Riva et al. 2007).

## 2. EXPERIMENT

Previous researchers have demonstrated that there was no differential effect of colour and light on heart rate and blood pressure (Caldwell and Jones 1985). However, a significant number of publications have demonstrated that colour and light is associated with mood and emotion (Ou et al. 2004). This work primarily examines subjective emotions and physiological responses to colour in both a physical room illuminated using Thouslite LED system (Figure 1a,b) and a virtual reality (VR) simulation of the same test environment (Figure 2a) using the Oculus Go VR headset (Figure 2b). A further objective of this work is to evaluate how the impact of colour and light have the potential to positively impact on engagement and wellbeing in VR. The experiment was specifically designed to investigate the effect of human's responses utilising Positive and Negative Affect Schedule (PANAS) and electroencephalogram (EEG) (Figure 3) under two lighting conditions (i.e., red and blue), compared to the white lighting condition in both the physical environment and VR.



Figure 1: a) The three coloured-lighting conditions in the physical environment. Note that the computer was not in the environments in both physical and VR experiments. b) The interface of Thouslite LED system.

### 2.1 Procedure

A total of ten university students (23-42 years, median = 24) participated in the experiment, comprising five females (24-42 years, median = 28.8) and five males (23- 28 years, median = 24.2). All subjects signed informed consent before the experiments, which was approved by the ethical review committee at University of Leeds (Ethics reference: LTDESN-097). Participants were invited to seat for 20 minutes in each of the three lighting conditions (sequenced as white, red and blue), respectively (Figure 1a). Between each coloured-lighting conditions, there was a 15-minutes break where the white lighting condition was provided. A week after the physical experiment, the same experiments were repeated in VR (Figure 2b). The EEG signals and heart rate (HR) of the participants were measured over time of each course of each experiment. During the data acquisition, all participants wore the wireless sensor headset that acquired EEG from the bi-polar sensor sites F3-F4, C3-C4, Cz-POz, F3-Cz, Fz-C3, and Fz-POz (Figure 3). These measurements are used to examine how human respond physically. After each coloured-lighting session (i.e., during the 10-mins break), participants were asked to fill the PANAS.

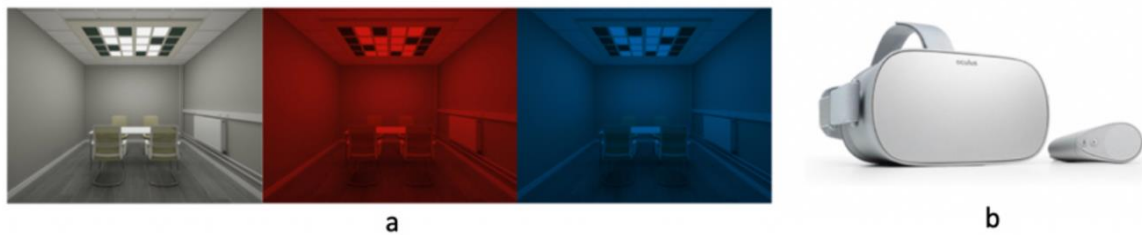

Figure 2: a) Oculus Go VR headset. b) The three coloured-lighting conditions in the VR created by 3DS Max.

## 2.2 Lighting conditions under the Thouslite LED system and VR

The Thouslite LED system provides a laboratory controlled lighting environments for colour temperature and colour experience, so that characteristics in particular mood, focus and productivity can be established (see Figure 1a). The dimension of the exposed area was approximately 3.5m (L)\*, 3.43m (W)\* and 2.65m (H)\*. The luminance (Lumi (lv): 24 (7.6)) of the three experimental coloured-lighting conditions (white, red and blue) was measured by iPro X-rite (a specialist equipment to measure the colour and luminance) and then set up by using the Thouslite LED system. Other environmental conditions including air temperature, and humidity, furniture and layout settings remained consistent and procedures were conducted in the silent model. In the VR, simulated coloured-lighting conditions were reproduced using 3DS Max and delivered via the Oculus Go VR headset (Figure 2a, b). Colour and luminance conditions in the VR were measured and set up using i1Pro X-rite to ensure that the luminance of the three coloured-lighting conditions in the VR are exactly the same as in the physical experiments.

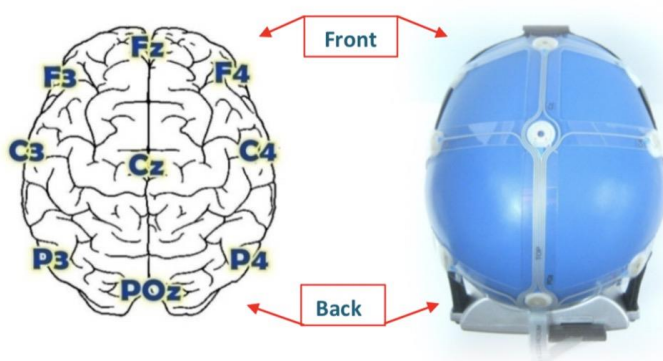

Figure 3: Electroencephalogram (EEG) headset.

## 2.3 Results

Subjective emotions were recorded and assessed using PANAS. *T*-test was performed to show the significance of the difference between the three lighting conditions, and between physical and VR environments (Figure 4). Figure 4 indicates that there are differences between white, red and blue lighting conditions in the physical environment with respect to the levels of positive and negative affects. However, there was no effect on the levels of positive and negative affects in VR. Specifically, we found statistically significance in participants' positive affects ( $n = 10$ ,  $p = 0.014$ ) between white and blue lighting conditions in the physical environment. For participants' negative affects, statistical significances are found between white and red lighting conditions ( $n = 10$ ,  $p = 0.024$ ), as well as between the red and blue lighting conditions ( $n = 10$ ,  $p = 0.021$ ) in the physical environment.

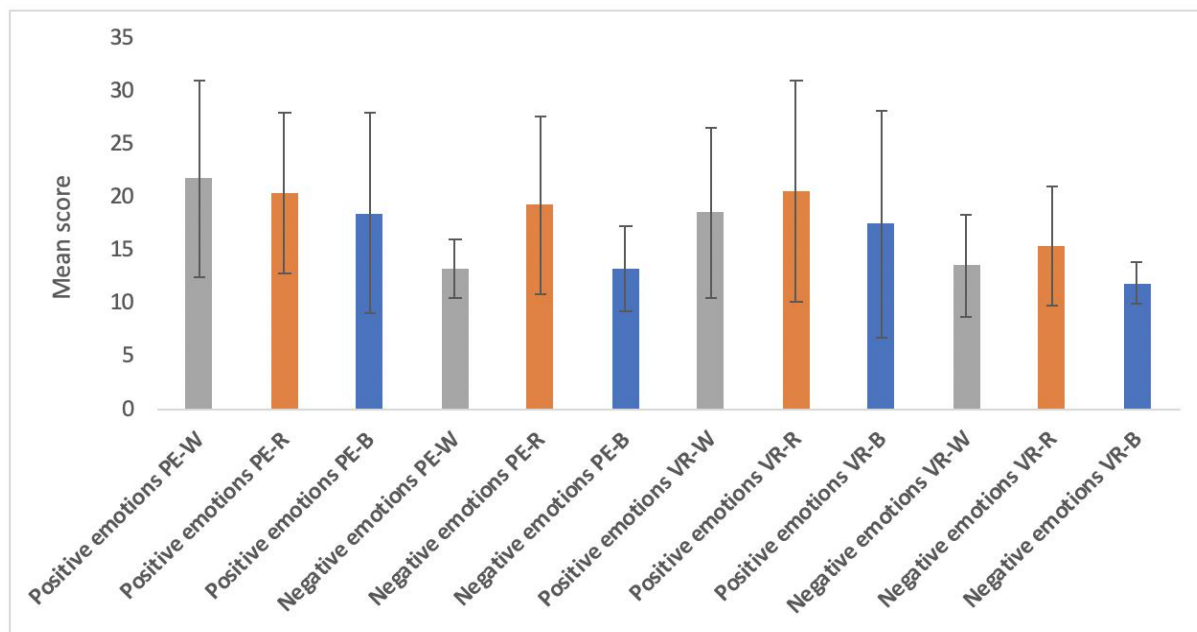

Figure 4: Response in participants' positive and negative emotions as measured by PANAS under white (grey bars), red (orange bars), and blue (blue bars) lightning conditions, in physical environment (suffixed as PE) and virtual reality (suffixed as VR). The bars represent mean changes, while the error-bars are the standard deviation across individual participants.

The B-Alert Live system with active electrodes was used for EEG recordings. Electrodes were placed on participants' scalps according to the international 9 system at Fz, F3, F4, Cz, C3, C4, POz, P3 and P4 (Figure 3). Two extra electrodes were attached to both earlobes to serve as reference electrodes for those attached to scalps. EEG data were gathered using B-Alert Live Software (BLS) as well as wireless Advanced Brain Monitoring (ABM) EEG headset. The post-processed z-Score of fzclass\_3 (theta total at the channel f3) and Z-Score of f3class\_6 (alpha total at the channel f3) were analysed, respectively. Note, the channel f3 of the B-Alert Live system headset is one of the electrodes at the frontal site, and fz is one of the electrodes at the midline of the brain. To remove individual variability from various metrics, the z-score for this purpose is calculated on the mean and standard deviation for at least the first 5 seconds, with additional epochs (seconds) added. *T*-test was performed to show the statistical significance of the differences between lighting conditions, and environments (Figure 5).

In the physical environment, the normalized alpha range at the channel f3 is shown to be lower under the blue lighting condition than that under red lighting condition ( $n = 10$ ,  $p = 0.012$ ). This implies that the alpha range at the channel f3 was significantly affected by the blue light. However, there is no statistically significant difference ( $n = 10$ ,  $p = 0.102$ ) in the normalized alpha range at the channel f3 between white and red lighting conditions. Also, Figure 5 shows a very significant difference ( $n = 10$ ,  $p = 0.005$ ) in the normalized theta range at the channel fz between white and blue lighting conditions in VR. No significant difference ( $n = 10$ ,  $p = 0.225$ ) was found in the normalized theta range at the channel fz between white and red lighting conditions in VR. Participants' paired *t*-test result also shows a significant difference ( $n = 10$ ,  $p = 0.050$ ) in the normalized alpha range at the channel f3 under blue lighting condition between the physical environment and VR.

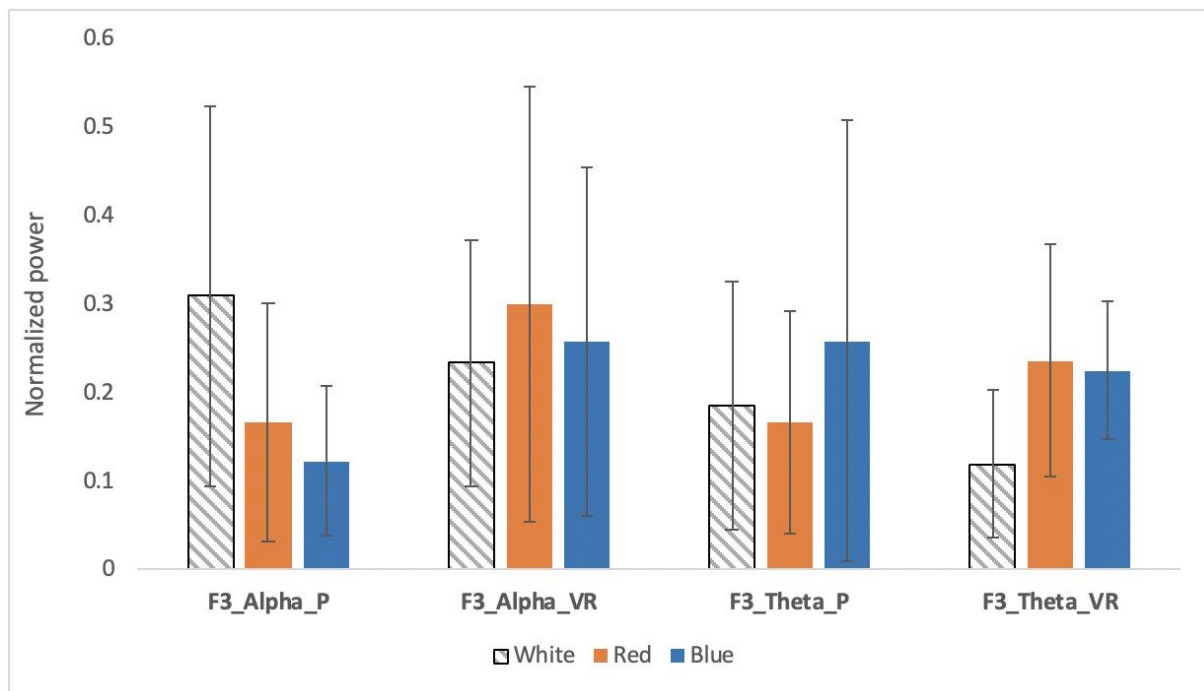

Figure 5: Ten participants' mean  $\pm$  standard error of the mean normalized EEG power alpha (8-12 Hz) and theta (3-7 Hz) frequency ranges in the f3 channel under white (pattern bars), red (orange bars) and blue (blue bars) lighting conditions in both the physical environment and VR during the last 15 minutes.

### 3. DISCUSSION

Our results suggest that participants' negative affects increase under red lighting condition, but reduce under the blue lighting condition. This supports Birren (1961) who reported that red colours are associated with negative feelings such as anxiety, anger, and annoyance, while blue colours are associated with feelings of relaxation and calmness (Naz and Epps 2004, Birren 1961).

For EEG, the normalized alpha range at the channel f3 is shown to have a significant decrease ( $n = 10$ ,  $p = 0.012$ ) under the blue lighting condition (compared with the white lighting condition) in the physical environment. Previous studies suggest that happiness caused less alpha power in the left frontal region (Davidson et al. 1990). It has been also suggested that blue colours are associated with relaxation and calmness (Birren 1961). Our result suggests that the blue lighting condition in the physical environment is likely to increase people's positive emotions. However, this contradicts with participants' PANAS assessment, which shows a decrease in positive affects between white and blue lighting conditions.

In VR, a significant increase ( $n = 10$ ,  $p = 0.005$ ) was found in the normalized theta range at the channel fz under the blue lighting conditions (compared with the white lighting condition in VR). Sammler et al. (2007), demonstrated that increases to frontal midline (fm) theta power is associated with pleasant music. Also, Fischer et al. (2018) showed that an increase to scalp-wide theta activation can be explained as a mind-wandering effect. Even though the theta range we analyzed here is at the single electrode fz, our result suggests that participants feel relatively more calmed and relaxed under blue lighting condition than under the white lighting condition in VR. The result agrees with the PANAS assessment regarding the negative affects between white and blue lighting conditions in

VR, whereas no statistically significance was found in the PANAS. Participants' paired t-test results show statistically significance in the normalized alpha range at the channel f3 under blue lighting conditions between real-world and VR. Specifically, the result might suggest that different presence might be perceived by participants under blue lighting conditions between the physical environment and VR. However, the impacts of blue lighting conditions between the physical environment and VR are shown to have no statistically significance in the normalized theta ranges at the channel f3. Also, no significant differences were observed in white and red lighting conditions in both alpha and theta ranges.

One of the limitations of this study is we only had 10 subjects, while in the future further experiments will be performed to expand our findings. Also, the results of PANAS is questionable, since participants might mix their emotions between the start and the end of experiments.

#### 4. CONCLUSION

In this study, we investigated human's physiological responses to object colours by comparing data collected from the EEG, and subjective emotion assessment (using PANAS) under a Thouslite LED system and a reproduced VR environment. We found statistically significant differences in (a) participants' positive affects between white and blue lighting conditions in the physical environment, (b) participants' negative affects between white and red lighting conditions in the physical environments, (c) participants' negative affects between red and blue lighting conditions in the physical environment, in terms of participants' subjective rating, (d) the normalized alpha (associate with relaxation) range in the left frontal region between white and blue lighting conditions in the physical environment, (e) the normalized alpha range in the let frontal region under blue lighting conditions between the physical environment and VR was found, (f) the normalized theta (associate with emotional states) range in the single electrode fz in VR between white and blue lighting conditions. In short, our results suggest that human's physiological changes in VR are consistent with physical lighting conditions. However, further experiments are needed to verify and expand these findings.

#### ACKNOWLEDGMENTS

We appreciate all the participants at the University of Leeds who took part in the experiment.

#### REFERENCES

- Birren, F. 1961. *Color psychology and color therapy; a factual study of the influence of color on human life*. New Hyde Park, New York: University Books.
- Caldwell, J. A., and G. E. Jones. 1985. The effects of exposure to red and blue light on physiological indices and time estimation. *Perception* 14: 19-29.
- Czeisler, C. A., J. S. Allan, S. H. Strogatz, J. M. Ronda, R. Sanchez, C. D. Rios, W. O. Freitag, G. S. Richardson, and R. E. Kronauer. 1986. Bright light resets the human circadian pacemaker independent of the timing of the sleep-wake cycle. *Science* 233: 667-671.

- Davidson, R. J., P. Ekman, C. D. Saron, J. A. Senulis, and W. V. Friesen. 1990. Approach-withdrawal and cerebral asymmetry: emotional expression and brain physiology. I. *Journal of Personality and Social Psychology* 58: 330-341.
- Eastman, C. I., M. A. Young, L. F. Fogg, L. Liu, and P. M. Meaden. 1998. Bright light treatment of winter depression: a placebo-controlled trial. *Archives of General Psychiatry* 55: 883-889.
- Fischer, N. L., R. Peres, and M. Fiorani. 2018. Frontal alpha asymmetry and theta oscillations associated with information sharing intention. *Frontiers in Behavioral Neuroscience* 12.
- Lyon, M., S. Ownbey, and R. Russ. 2012. Choices for colour, light and line of women living in continuing care retirement communities in the USA. *Journal of the International Colour Association* 7: 73-83.
- Naz, K., and H. Epps. 2004. Relationship between color and emotion: A study of college students. *College Student Journal* 38: 396.
- Oh, J. H., S. J. Yang, and Y. R. Do. 2014. Healthy, natural, efficient and tunable lighting: four-package white LEDs for optimizing the circadian effect, color quality and vision performance. *Light: Science & Applications* 3: e141.
- Ou, L. C., M. R. Luo, A. Woodcock, and A. Wright. 2004. A study of colour emotion and colour preference. Part I: Colour emotions for single colours. *Color Research and Application* 29: 232-240.
- Riva, G., F. Mantovani, C. S. Capideville, A. Preziosa, F. Morganti, D. Villani, A. Gaggioli, C. Botella, and M. Alcañiz. 2007. Affective interactions using virtual reality: the link between presence and emotions. *Cyberpsychology & Behavior* 10: 45-56.
- Sammler, D., M. Grigutsch, T. Fritz, and S. Koelsch. 2007. Music and emotion: Electrophysiological correlates of the processing of pleasant and unpleasant music. *Psychophysiology* 44 (2): 293-304.
- Volpe, V. 2016. Can colour enhance emotional well-being in a primary care non-clinical consulting room? –A mixed-method study. *Journal of the International Colour Association* 15: 19-30.
- Westland, S., Q. Pan, and S. Lee. 2017. A review of the effects of colour and light on non-image function in humans. *Coloration Technology* 133: 349-361.

# Colour and light in exterior architectural illumination: from efficiency to aesthetics

Mariana Noguera\*, João Pernão

Universidade de Lisboa, Faculdade de Arquitectura, Lisbon, Portugal

\* arqmariananog@gmail.com

## ABSTRACT

With all the changes in urban life brought by artificial light, and now with new technologies, today we see new forms for the presentation of architecture and the urban space in the night-time, which distance the latter from their daytime legibility regarding colour, texture and form. Now, owning the power for transformation brought by light, we must reflect upon the essential parameters that ensure the correct presentation of architecture and its relation to, and hierarchy in, urban space. On one hand, these parameters rely on technical solutions. On the other hand, they rely on aesthetic reasons that should consider the values of preservation of the identity of the building and the perception of space, instead of conveying the light designer's idiosyncratic ideas.

Regarding heritage sites, the presentation of architecture during day and night, although necessarily different, should not present different readings. In general, we have more light than we need in our cities at night, which promotes light pollution... In the end, there is a discussion about the dichotomy between efficiency and light aesthetics, each not always able to partner with the other in their results.

This paper discusses examples taken from Lisbon at night, and elaborate conclusions towards a better use of light for architectural lighting.

**Keywords:** *architecture, light, colour, artificial lighting, perception*

## ANALYSIS AND DISCUSSION

The widespread use of artificial light has brought great change to our lives, namely in relation to the use of the urban space. It has profoundly modified not only our lifestyle, but also our perception of the environment built mainly during the night, but also during the day. Night lighting interferes directly with the perception of architectural form and with the hierarchy of urban shape. It is responsible for detaching or concealing some details of a building or for detaching or concealing one building amidst the others. One other problem is that technical apparatus is needed for architectural



lighting (luminaires, reflectors, lighting poles, etc.), and they are usually not well related to the architecture or the urban space, which interferes with the quality of the building's presentation.

In Figures 1 and 2 we can see a lighting pole with six lamps placed in a corner building on the street of Alecrim in Lisbon. The objective is to illuminate the Church of Nossa Senhora da Encarnação. For those who go up the street, the effect caused by these lights at night is quite uncomfortable and interferes with the vision. During the day, the visual impact of this apparatus, on such an ancient area, is even more disturbing.



Figures 1, 2: Rua do Alecrim and Igreja de Nossa Senhora da Encarnação, Largo do Chiado, Lisbon, Portugal. Photos Mariana Noguera.

The new lighting technologies have brought different possibilities to present the architectural structures, working with different intensities, different color temperatures, different illuminance, etc. Historically, when there was not any public illumination, only the buildings of major importance were illuminated, and sometimes just on special occasions. With the technological development, the use of artificial lighting was simplified making common what before had an exceptional character. Today, all the great cities are entirely illuminated, the majority without parameters that contribute to an interpretation of space and their nocturnal imagery. The night, which could be the protagonist of elements forming a new three-dimensionality, with diverse nuances between the light and the dark, shadows of different intensities and vibrant colors, often seems to lose this atmosphere to interpretations that end up generating distortions and discomfort through exaggerated interventions.

In Figure 3, at Trindade Street, in a very well-preserved heritage neighbourhood, there are various types of lighting, each of which focused on the building to be illuminated, disregarding any integration in urban space environment. On the right side, a common streetlamp, with warm light colour temperature, inefficiently illuminates the space below. The light is blocked by the open umbrellas of the restaurants occupying the sidewalks, who in turn light their own lights. Above, in the same building, a cold colour temperature illumination incomprehensibly enhances the last floor. At the front there is the pink illumination of the Trindade Theatre, which during the day has a rose colour painting, much more sober than this night light. This night illumination also disregards the ornaments and the details painted in white on the contours of the windows. On the left, a building being rehabilitated is again illuminated with a cold temperature light, almost bluish, expendable and unnecessary. This is a typical example of what happens when there is no integrated light planning, resulting in a lack of visual identity that alone could organize and respect public space as one.



Figure 3: Rua Trindade, Lisbon, Portugal. Photo Mariana Noguera.

At night, light can model space and what is seen, by choosing the elements that will be highlighted. The hierarchy conveyed by lighting, modifies and evidences the references of space. But these choices can completely modify the presentation of the architecture from day to night. We have to understand concepts such as visibility, used simply to get enough night vision to walk, drive or make the public space safe, which differs from the concept of legibility, in which the correct reading of a historical building is inserted in a way that it can be recognized at night, as it is during the day. The public lighting, which prioritizes the amount of light, allowing objects to be seen ahead, is not thought in terms of legibility, and usually makes the night monochrome. A lighting that considers architectural legibility, could go beyond the utilitarian functions, revealing the space with greater variety, and bringing recognition and hierarchy to the elements that constitute the city, and thus giving it personality.

In Figure 4 we see Palacio Chiado in Lisbon, which is grey during the day, but at night gains an orange tone (sodium light). Despite of the colour change, this illumination is not hostile to its environment because these lights have the same colour temperature as the public illumination nearby, and they are placed inside the old lamps on the facade. The lighting is smooth, so the distortions are not so evident. Still, the building is different in daylight, and the marked shadows of the narrow-focused lights on the last floor, lighting from bottom to top, are not the best choice for the presentation of this classical building. Its identity is somehow faded. But one element that is very positive, is the presence of a warm temperature interior lighting that can be seen from the street. This element gives an impression of “soul” to the building, a lively presence that is not visible when we just light the facade of old buildings with no light inside (they appear to be dead, with no interior life).



Figure 4: Palacio Chiado, Rua do Alecrim, Lisbon, Portugal. Photo Mariana Noguera.

## THEORY

Light is dependent not only on its own characteristics, but also on the materials and surfaces that are illuminated. The surface that receives the illumination affects the perception of light. The surface can diffuse, absorb, transmit or modify the intensity and direction of light, depending on its characteristics. “What we see from the objects is not the light that focuses on the surface, but rather the light that they reflect” (Pernão 2017).

This is a fundamental aspect to pay attention to in the lighting project. Reflected light is not only important to the building to be worked on, but also for its near environment that will also be affected. The illumination reflected in historical buildings is considered the most comfortable to the eyes of the pedestrian, because it enhances important buildings and also because the surface of these buildings usually has a porous and matte stone finish, which, with the correct light temperature and illuminance, creates a very pleasant ambience for those who pass by.

This all raises many questions to be discussed:

- Can we define what will be a correct illumination for a specific architecture?
- How can we illuminate without causing any kind of distortion to the perception of architecture?
- Should the aesthetic attitude of lighting design dominate the presentation of the object?
- Are we preserving the right hierarchy in urban perception?

The quality of the light used, its intensity and the direction in which it is installed, define what will be the reading obtained from the architecture of the building. This reading can value details that are

not visible in daylight, promoting a different appreciation of the object by artificial light, but this should be done without disfiguring or modifying the building's perception. The effect of the light is what should be evident, not the light itself. "The element is not light, but how to use it" (Pernão 2017).

In the Taxco Charter there is a whole argument about enlightenment in historical goods and centres that says "the implantation of artificial lighting systems in monuments and historical centres requires establishing criteria and norms regulating the adequate management of artificially produced light in harmony with its goods and cities; that do not attempt, mutilate, deteriorate or alter their aesthetic qualities, formats, materials of historical monuments" (INAH 2012).

Since light can profoundly change the perception of what is being illuminated, we must define parameters for a correct perception and preservation of the characteristics of the building, its colour and materiality, its parts, its identity, and its role in urban space.

We must also consider the visual comfort of artificial lighting in relation to its inhabitants, avoiding the excessive level of illumination, brightness and excessive contrasts. In relation to the urban space and its hierarchies, the light can re-qualify the urban space and create a visual identity of the city, "since an interesting property of artificial light is the ability to reconstruct and manipulate the perception of spaces". The light can work in favour of historical elements, more interesting to the public space, thus decreasing the reading of less interesting elements that instead are not so interesting (Del-Negro 2012: 12).

We could use different colour temperatures in urban space lighting, not randomly, but helping to define different environments, or different hierarchies, enhancing the buildings that are most relevant (heritage buildings for example) of other less important ones. Sometimes we see common and uninteresting buildings being excessively illuminated, because of commercial interest, to the detriment of others that are much more important because of their architectural and cultural value. The city could protect itself in this aspect, directing the designers and architects of illumination so that the night visual is protected, qualifying the space through a lighting that guarantees quality both in comfort and interest for its heritage.

## **CONCLUSION**

This research is not technically oriented in the field of lighting but tries to relate the perception of architecture and the inherent characteristics of its colour and shape in the transition from day to night. We propose the following parameters, to bring the discipline of architecture into the lighting project, working from techniques to aesthetics:

- i. Technical solutions must always comply with the superior objectives of the correct architectural presentation.
- ii. The aesthetic idiosyncrasies of the light designer should be reserved to improve the architecture when working with its authors, or in ephemeral events, and never be applied in heritage buildings. In this case, we must observe the recommendations expressed in the Taxco Charter.
- iii. We must always preserve the identity of the building, eventually reinforcing its details and never losing their importance regarding the identity and coherence of the building.
- iv. We must observe the building in its natural and/or artificial environment, and its characteristics of contrast and continuity in perception.

- v. One should consider the balance between the desired effect of architectural lighting and its the impact on visual comfort in urban space life.

By observing these objectives, we will have a less technical and perhaps less economically efficient solution, but we will certainly have a more sensible, comfortable and correct interpretation of the object. Modesty and common sense should be the most cultured and appropriate attitude to the lighting project in architecture, especially in historical environments.

## REFERENCES

- Del-Negro, D. 2012. *Arquitectura em luz: a iluminação exterior do património*. Casal de Cambra, Portugal: Caleidoscópio Editora.
- INAH (Instituto Nacional de Antropología e Historia), ed. 2012. Chart of Taxco 2009. Mexico.
- Pernão, J. 2017. In praise of the identity of architecture and urban space: problems on the perception of colour, materiality and form under artificial lighting.

# LEDs and urban landscape

**Carlos Colonna\*, Pablo Ixtaina, Agustín Pucheta**

Laboratorio de Acústica y Luminotecnia, Comisión de Investigaciones Científicas de la Provincia de Buenos Aires (LAL-CICPBA), Argentina

\* lionelcolonna@gmail.com

## ABSTRACT

The changes in lighting technology are reflected as variations in the perception and appearance both of the lighting installation and the objects to be lit. These variations are significant when the luminous source spectrum is the main factor of the technological progress. As regards street lighting, the incandescent emissions were the protagonists during the early years, between the seventeenth and nineteenth centuries, or even earlier. The original oil or gas lamps were then replaced by incandescent lamps, at the beginning of the twentieth century, keeping warm color temperatures and continuous spectra. The discharge sources introduced later the “limited” spectra, with limited emission lines, which significantly altered the perception of the public space, especially the sodium lamps, prevailing in our country since mid-1980s. Nowadays, LED technology introduces a new paradigm: shapes in the emission that leave aside the traditional lamp and a white light spectrum with a strong focus on the blue color. This last issue is dealt in the present article, studying the effect in the perception of signals and color signs, homogeneity in the color of LED luminaries and the spectrum effect in the lighting pollution.

**Keywords:** *LED, lighting pollution, retroreflective, electromagnetic spectrum*

## INTRODUCTION

Since the 1980s, the amber color has prevailed in the urban landscape: roads, highways, streets, parks and squares. The luminaries with high pressure sodium lamps (HPS) have been the favorite light sources due to their great efficiency and long service life. The HPS lamps have coexisted with modern white light sources, mercury lamps with metal halide (MHL). Their chromatic improvements compensate a short life service and a poorer efficiency, being used for situations with high visual demand, such as commercial streets or important green areas, at the cost of energetic efficiency in the interest of a better visual impact.

Today we are experiencing a revolution in artificial lighting. HPS, MHL lamps and other technologies of traditional light (incandescent, mercury discharge lamps of high and low pressure) are being replaced by LEDs: light-emitting diodes. The change, which is already total in some regions in

Asia, USA or some European cities, is progressing in our country at an uneven pace: it is practically complete in Buenos Aires city, partial in capital and big cities, and emerging in the rest of the country. In any way, it appears to be an irreversible change in the way of lighting.

### **LIGHT-EMITTING DIODES**

A LED is a solid state device that produces photons directly. The high efficiency, long service life and (the most important) a strong commercial impulse together with the practicality of an electronic device, transformed LEDs into the exclusive future light source. Mainly, a LED consists of a semiconductor joint that, with a suitable current releases energy in the form of light (photons) from the recombination of holes and electrons in the joint region. In order to emit light, the obtained photons should be within the visible spectral range, i.e., between 380 and 780 nm. Depending on the base material of the semiconductor, it is possible to obtain different dominant wave lengths, one per joint. In other words, LEDs have color, being possible to obtain an emitter LED in green, red, blue, orange, etc.

In principle, a single LED cannot generate white or polychromatic light. This limitation can be solved in many ways, the techniques used nowadays are photoluminescence and additive mixture of colors. The first procedure, almost exclusive in street lighting, is achieved by applying a thin coat of phosphorous on a “blue” joint LED (phosphor coated PC). The short wave energy emitted by the joint stimulates the phosphor coat, exciting it. Thus, it is achieved a secondary emission, centered on green-yellow colors, which reaches the red zone and completes the blue color of the joint. The result is white light with the possibility of achieving different color temperatures according to the used phosphorated compounds. Besides, phosphor properties allow “covering” more the spectrum towards red color, effect linked to the achieved chromatic reproduction index. The second method is based on the principle of additive mixture of colors, combining red, green and blue lights (RGB), from the combined encapsulation of three joints with the corresponding colors and due to the integration that the human visual system has. The achieved efficacies are lower if compared with the previous method, being kept for decorative applications or image systems: LED TVs, cell phone screens, signage, among others.

### **RETROREFLECTIVE MATERIALS**

Retroreflective materials are those which are used in the street signaling. They are marketed as flexible sheets and are applied on a support giving them body, generally from metal. As well as the characteristic color, they have an inner optical structure that allows them to reflect the incident light (from the vehicle), mostly projecting in direction towards the light source. Each color is intended to convey necessary information to drivers and pedestrians and obviously, due to risks related to traffic, it is required a correct color discrimination (Figure 1a).

The color characterization is carried out under two lighting conditions, a daytime condition and another nocturnal (ASTM 2013). The former, intended to reproduce the observation condition under sunlight, is assessed by using a source that simulates the natural light spectrum, illuminant CIE D65 (CIE 2006). The latter is used when the incident light source is an incandescent lamp, situation that takes place in the case of a vehicle driver during night time. In such case, the test uses a standardization of the incandescent spectrum, known as A illuminant (CIE 2006). The color

characterization is carried out on test tubes, in standardized lighting and observation conditions: normal lighting on the surface and observation at  $45^\circ$  (geometry  $45^\circ / 0^\circ$ , according to cited ASTM). A spectrometer is used as detector, from whose output (reflected light spectrum) the chromatic coordinates of the sample are obtained according to CIE (ISO/CIE 2019, Ohno 2000) (Figure 1b).

The hypothesis of this study was to consider that the use of LEDs in the vehicle lighting systems produced, by the LED light spectrum itself, changes in the signal colors that made the tests standardized as measurement according to “night light” meaningless. The experience consisted of measuring samples according to the condition set by ASTM standard as “night light” (A illuminant) and comparing the results under LED lighting. Figure 2 shows the spectra used in the measurement.

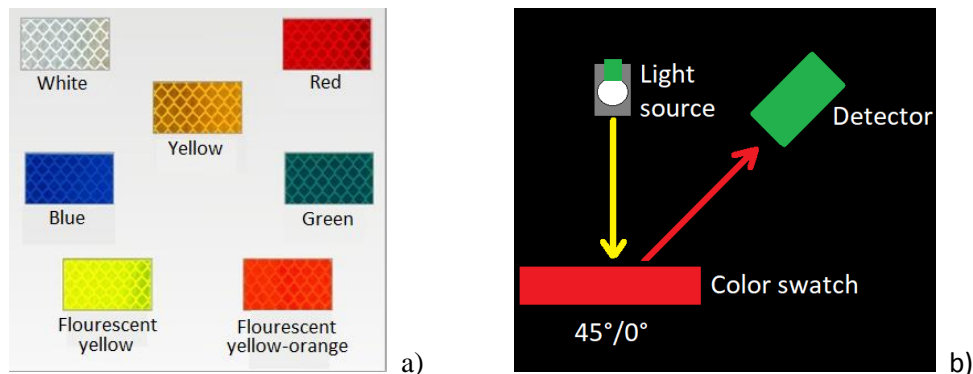

Figure 1: Samples of retroreflective materials (a) and measurement system (b).

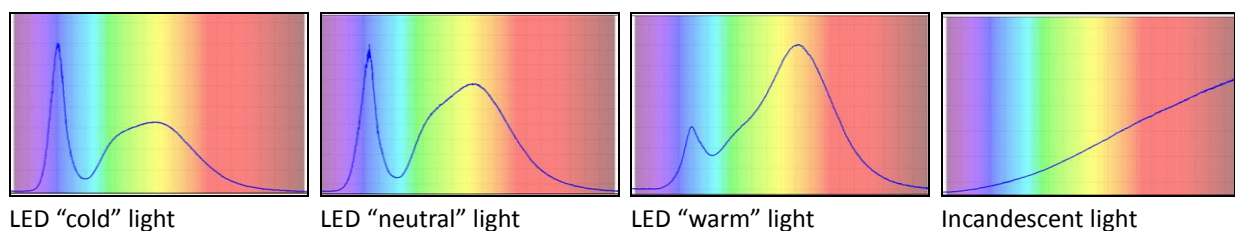

Figure 2: LED source spectra used in the illuminant A experience and simulation.

The obtained results, for white, blue, red and green plates, are shown in Figure 3, together with the limits established by the standard for colors according to “day light” and “night light”. In the zone of red-orange colors, the reproduction of different LED sources tends to less saturated colors, with shifts towards the diaphragm center, pronounced with the source considered as “cold” light.

In the blue color, it is observed a tiny dispersion between the natural light reference and the “cold” and “neutral” LED sources, which become a saturated reproduction. In the case of “warm” and incandescent source, saturation is lower. The green color is located in the upper zone of the graph, where it is observed a shift from “cold” LED and natural light towards white color (in the center of graph), for the case of that incandescent, the “warm” and “neutral” LED, towards yellow (on the right of graph). For the white stripes, the cold and natural light are included within day limits, that neutral is slightly outside, towards the red zone and the warm and incandescent lights present a greater difference tending to orange-yellow.

In short, it can be confirmed that the cold LED source is close to the natural lighting, except for the red reproduction. Then, those “warm” and “neutral” (except for that blue) match the results of the incandescent source. Thus, thinking about a near future when the street lighting systems are based



on LED sources, it can be concluded that it will be necessary to establish the type of light to be used (warm or cold) when normalizing the colors under night lighting. Surely, it will be necessary to study this in depth, though it seems appropriate to conclude that the present definition of “night” condition loses sense, since globally, the LED sources generate colors much closer to day condition in the chromaticity graph.

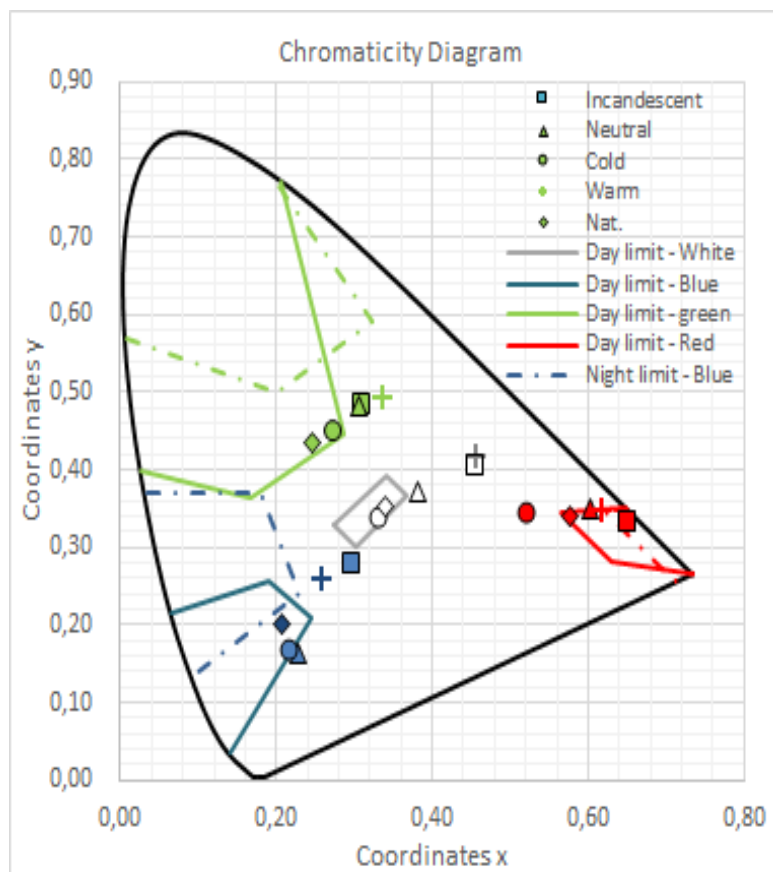

Figure 3:  
Chromaticity graph.

### INFLUENCE ON ASTRONOMY

Light pollution is understood as the brightness or radiance of the night sky, produced by artificial light diffusion. The result is a decrease of night darkness that produces a visual disappearance of the starry sky. The direct effect is the loss in the observation capacity in astronomy. On one hand, whatever the polluting source, the increase of sky clarity establishes a limit to which the LED spectrum is added. In fact, the spectral window between 380 a 490 nm, very rich in astronomic information, is strongly affected by the blue joint of LED which must be preserved (Ixtaina and Sanhueza 2016).

In the context of an agreement between LAL and Las Campanas Observatory (La Serena, Chile) with the collaboration of the Office of Quality Protection of the Northern Sky of Chile (OPCC), a research was carried out aimed to keep the technological advantages of LED lighting, adapting the spectrum so that it could be apt for the protected zones of the north of Chile (Minecon 1998). The regulations in force specify that between 300 to 499 nm the spectral irradiance shall not exceed 15% of the visible spectrum. The conventional LED luminaries do not meet these requirements: they have in the blue color 23% of the visible spectrum much above the percentage specified by the regulations. The work consisted of applying a spectral cutout by means of suitable filters, obtaining a

simple and cost-effective solution that allows reducing the contamination in the blue zone of the spectrum without special equipment.

For the experience, it was used PVC films stabilized to ultraviolet radiation, with bright surface. The material is adhesive-type, enabling to color the luminary refracting cover, introducing the only limitation of the method: the luminary should be High or Mid-Power LED-type (not COB) and with a smooth protecting cover on the lens.

In the colorimetric tests, the spectra and color temperature were obtained with three different filters and the photometry test provided us the efficacy that results from attaching the PVC film. With the results it is possible to compare an amber PC-type LED luminary and an amber luminary that were thoroughly studied in previous works (Sanhueza and Ixtaina 2017). The three chosen filters worked complying with the standardized requirements about the total spectrum elimination in the protected band (Figure 4). In a first instance, any of the chosen filters could be used for the experience.

One of the main characteristics that the “filtered” luminaries must have is to keep an efficacy compatible with the technologies in use. The factor for weighting it is the ratio between the luminous flux and the total power consumed, light efficacy (lm/W). The results obtained from the photometry test showed greater efficiencies than those obtained through other technologies, such as that amber PC. Thus achieving, a limited spectrum luminary, apt for protected sky zones, of high efficacy and a cost practically similar to a conventional white LED, with the only limitation of requiring a plain refracting cover for attaching the filter (Table 1).

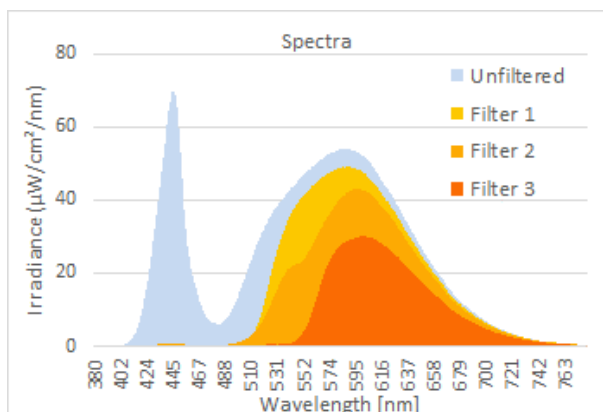

Figure 4:  
Luminary spectrum with and without filter.

	Unfilter	Filter 1	Filter 2	Filter 3	Amber LED	Amber PC
<b>Power (W):</b>	44,0	44,0	44,0	44,0	56,4	144,0
<b>Luminous flux (lumen)</b>						
Lower hemisphere, side road:	3.063,3	2.380,1	1.901,4	1.079,7	2.100,0	4.900,0
Lower hemisphere, sidewalk:	1.052,8	922,1	713,9	541,3	600,0	2.400,0
Lower hemisphere, total:	4.116,1	3.302,2	2.615,3	1.621,0	2.700,0	7.300,0
Upper hemisphere, total:	0,0	0,0	0,0	0,0	0,0	0,0
Total flow:	4.116,1	3.302,2	2.615,3	1.621,0	2.700,0	7.300,0
<b>Effectiveness (lm/W):</b>						
	93,6	75,1	59,5	36,9	47,9	50,7
<b>Loss, compared to the unfiltered (%):</b>						
	-	19,7	36,4	60,6	48,8	45,8

Table 1: Fluxes and efficacies.

## SPATIAL DISCREPANCY OF THE SPECTRUM

Another issue that is latent is the spatial disparity of the chromatic features. In order to understand this phenomenon, the LED functioning must be analyzed. It has been already mentioned that the used devices are based on a blue joint to which a phosphorated film is overlapped. The adherence process from the coat to the chip varies according to the manufacturing model and technique, but for most power LEDs, the light emitted by the joint crosses different thicknesses of phosphorated film according to the output angle (the more slanted the beam, the more coat). There are several techniques for solving this phenomenon, however, it can be observed a lack of spatial homogeneity in the color temperature  $T$  of the final product (luminary).

Even though this change may not represent a greater influence in the chromatic reproduction, it may in the global aesthetics of the installation: sources of the same installation seen at a different distance (with different observation angle) are perceived as of a slightly different color. There are several experimental techniques of measurement for evaluating this phenomenon (Rivero et al. 2018), which is not provided for in the national standards (IRAM 2013, 2015). The studies carried out in LAL also reveal this phenomenon (Figure 5).

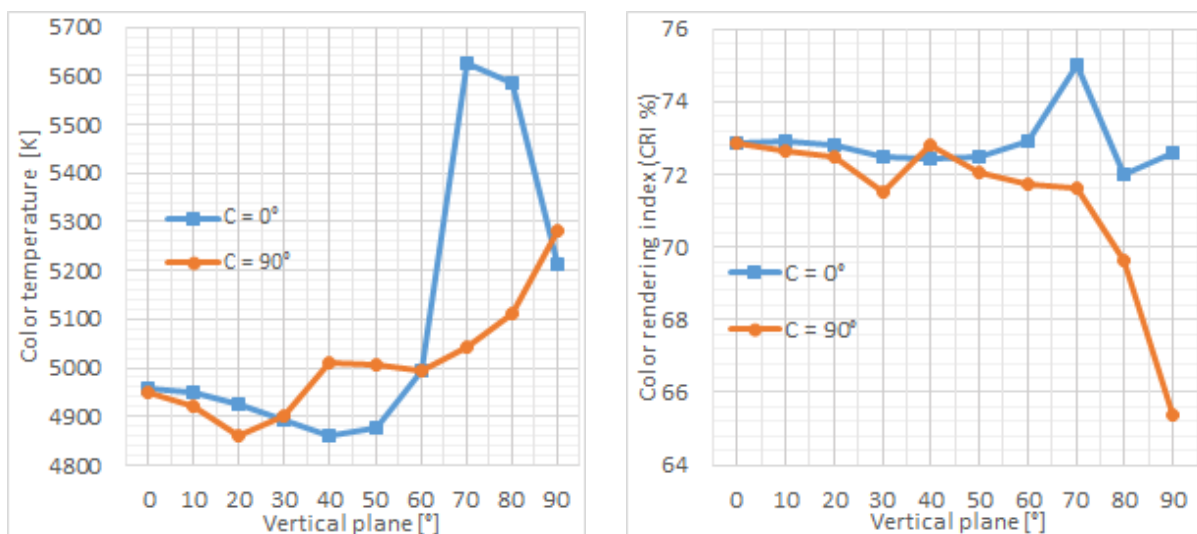

Figure 5: Special discrepancy of color temperature and color rendering index.

## CONCLUSION

Due to energy saving and the advantages of the optimal flux direction, LED technology has shown an increasing demand in its use and commercialization, but, on the other hand, there are the drawbacks presented throughout this work. The aim of this paper is to point out that the different regulations should take into account the differences or how the massive use of this type of artificial lighting can infer both the way of lighting and the reconsideration of the specified limits, with adaptive purposes, as it is a condition different from those stipulated.

## REFERENCES

- ASTM (American Society for Testing and Materials). 2013. D4956-13, Standard specification for retroreflective sheeting for traffic control.
- CIE (Commission Internationale de l'Éclairage). 2006. ISO 11664-2:2007(E) / CIE S 014-2/E:2006, Colorimetric illuminants, part 2: Standard illuminants for colorimetry.
- IRAM (Instituto Argentino de Normalización y Certificación). 2013. AADL J 2022-1, Alumbrado público Parte 1 – Luminarias. Clasificación fotométrica, 2013.
- . 2015. AADL J 2020-4, Luminarias para vías públicas, Características de diseño. Parte 4 – Luminarias LED, 2015.
- ISO/CIE (International Organization for Standardization / Commission Internationale de l'Éclairage). 2019. 11664-1:2019, Colorimetry – Part 1: CIE standard colorimetric observers.
- Ixtaina, P., and P. Sanhueza. 2016. Alumbrado vial de baja contaminación para la “Ruta del Algarrobo”, Chile. In: *Luxamérica 2016*.
- Minecon (Ministerio de Economía, Fomento y Reconstrucción, Chile). 1998. Decreto Supremo 686 / 1998.
- Ohno, Y. 2000. CIE fundamentals for color measurements. In: *International Conference on Digital Printing Technologies, 2000*.
- Rivero, N., M. Varela, and S. Machado. 2018. Homogeneidad angular de CCT en luminarias LED / Angular homogeneity in LED lamps. In: *Luxamérica 2018*, Córdoba, Argentina.
- Sanhueza, P., and P. Ixtaina. 2017. Polución lumínica. Luminarias no contaminantes para el norte de Chile. In: *Luz 2017 - XIII Jornadas Argentinas de Luminotecnia, 2017*.

# Dynamics of color and cesia in the urban landscape: transience and perception of differences

**María Paula Giglio**

Universidad Nacional de Mar del Plata, Facultad de Arquitectura, Urbanismo y Diseño  
Mar del Plata, Argentina  
mpgiglio@hotmail.com, geapmdp@gmail.com

## ABSTRACT

The landscape has a double existence, that of the observed and that of the observer. The landscape can be thought of as a “being / being-there”, and is possible to be described and explained in quantitative and qualitative terms. However, in this presentation we will approach the study of the landscape as a “being / in-change”, in order to understand it in the relationship between the observed, the observer and the light, as an open and dynamic construction that will allow us to reflect on the visual appearance in terms of transience and the perception of differences and their relationship with social and cultural aspects.

Visual appearance usually refers to a way of appearing, of becoming present. But the different modes of visual appearance of objects or spaces, overcome the notion of a static, homogeneous and subordinate perception, both of color and cesia. Thinking about visual appearance from a dynamic perspective of the phenomenon, allows us to understand it from the different ways in which it is presented, its transience and complexity, and in the different ways in which it is observed. To perceive this transience of the phenomenon demands to perceive the differences.

The differences in the perception of colors and cesias in the urban landscape not only occur between night and day, light and shadow, between the different spatial distributions of interior and exterior lights, by time or climate, for example, but are given by the intentionality of the observer’s gaze, based on the pre-condition that the observer must want to see. We accompany this reflection through the exploration of contextual relationships, situations, objects and spaces in urban context and daily life, the diversity of views and the knowledge of observers analyzed transdisciplinarily. The aim is to contribute to the study of visual appearance and the recognition of the importance of its recognition in the project processes of both artists and designers.

This work is part of the project “Visual appearance and morphology: the interaction between science and design in educational interventions”, whose aim is to study visual appearance and morphology from a multidimensional and transdisciplinary points of view, involving visual/spatial variables, their interrelation and the contextual relationship from the design disciplines.

**Keywords:** *color and cesia, visual appearance, urban landscape, perception, visual phenomena*



A shop window, inside and outside spaces.

When the observer is at a certain distance, reflections predominate over transparency.

When the observer gets closer, transparency is greater and the objects behind the glass appear more distinctly.

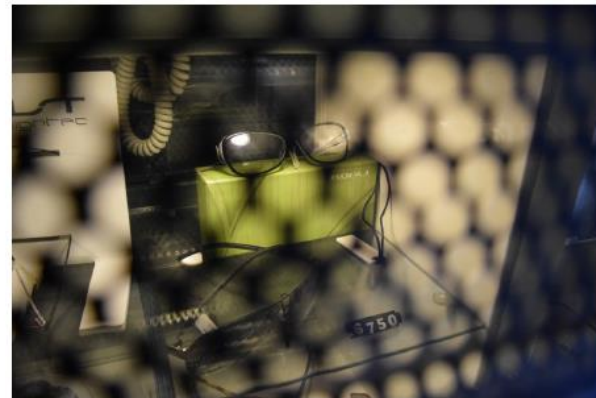

A shop window covered by a screened shutter: from near opacity to near transparency.

When the observer is at a certain distance, the surface of the shutter looks more opaque than transparent and objects behind it cannot be seen.

When the observer gets closer, the small holes of the shutter tend to disappear, and the effect of transparency increases.

# Architecture and Landscape



## C > 0 – Traditional façade neutrals are not achromatic

Kine Angelo\*, Alex Booker

Norwegian University of Science and Technology, Faculty of Architecture and Design,  
Department of Architecture and Technology, Trondheim, Norway

\* kine.angelo@ntnu.no

### ABSTRACT

This article examines the “neutral” façade colours of traditional Norwegian architecture and builds on previous research on establishing a colour guide for the city of Trondheim. Like most Norwegian towns and cities, Trondheim is foremost associated with painted façades in traditional hues and nuances of reds, yellows and greens, in combination with façades in nuances of “light to medium dark neutral colours of whites and greys”. The last decades have seen Norwegian architecture pointing towards a dramatic change in the traditional colour palette towards a perceived uniform, achromatic palette, often accentuated with chromatic, highly saturated colours, in stark contrast with the overall gestalt of the traditional colour identity. Previously, the authors have stated that façade neutrals are “but rarely achromatic”. However, further analysis of the colour registrations suggests that this statement is faulty, and that traditional neutral colours never were achromatic. Traditional pigments and building materials all had a chromatic content, and pigment composition used in traditional façade paints produced variations of “warm” and “cold” neutrals such as whites, greys and various stone colours. This is further discussed by examining the possibilities and limitations of the tools used in the colour registrations. This paper focus on the “neutral” façade colours, i.e. colours of painted wood cladding and rendered plaster, and the inherent colours of stone used in façades . As a conclusion, we have found that traditional façade neutrals were not achromatic and always had a chromatic content, thus giving the formula  $C > 0$ .

**Keywords:** *colour in architecture, neutral colours, pigments, pigment composition, NCS*

### INTRODUCTION

The city of Trondheim is foremost associated with painted façades in traditional, chromatic colours in combination with more neutral façade colours, and in identification of a colour palette reflecting tradition, history and culture, it has been necessary to determine what colours to exclude as well as to include in order to achieve an overall harmonic palette for future development.

When determining neutrals colours for the colour palette, the initial colour registrations of the project often pointed to NCS notations in the achromatic greyscale, i.e. NCS S 0300-N and NCS S



3000-N. From research and professional experience, we know that façade colours that are nominally achromatic are generally perceived as having a purplish-blue hue, and that the respective buildings in our project are commonly regarded as having different colours, e.g. “warm” or “cold” grey or “blue”. If we were to give these buildings the achromatic notations found in the initial colour registration, we risked changing significant colour attributes, i.e. from chromatic to achromatic, and possibly erase important chromatic diversity in the overall colour gestalt.

For the purpose of identifying a more accurate description for the façade neutrals, we have found our previous methodology inadequate, and needed further research. For this task, we have examined neutral façade colours with a focus on architectural practice; e.g. the colours of building materials, the necessary surface treatment used, and the relevant colour theories and professional tools. The arguments in this paper are based on Nordic research, light conditions, resources and architectural practice.

## METHODOLOGY

The Natural Color System (NCS) is a perceptual color model based entirely on the phenomenology of human perception and not colour mixing, and Norwegian Standard as colour reference system since 1984. The NCS tools used in the project are the NCS Atlas (perceived colours), NCS Index (nominal colours), NCS Colour Scan 2.0 and NCS Colourpin II (colour registration). Façade colours were registered as the nearest Standard NCS notations, and analysis show clear tendencies for a coherent use of chromatic colours and urban chromatic composition (Angelo and Booker 2016).

In Trondheim, we have previously stated that the general rule would be to exclude achromatic colours and colours with more chromaticness than 50%, and that included nuances should in general have a higher percentage of blackness than chromaticness;  $S > C$  (Angelo and Booker 2018). More specifically, analysis points to the use of typical hues and nuances of yellows, reds and neutrals, with occurrences of greens and rare blues, each following their own pattern (Figure 1).

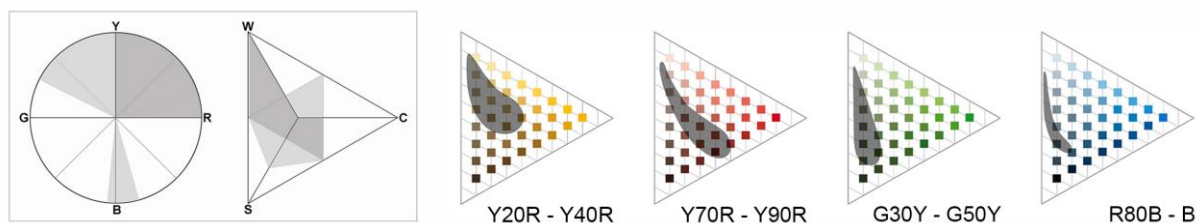

Figure 1: Left: General overview of hues and nuances in the Trondheim palette. Right: Specific nuance areas of the most typical hues.

Colour reference systems related to architectural practice, i.e. manufacture of paint and products, are most often restricted to a maximum of approximately two thousand (2000) hues and nuances. To represent the NCS colour space, a reduced set of colours was selected, and the current, standardised system contains 1950 colours (hereafter referred to as NCS 1950), denoted with a capital “S” in front of the colour notation, indicating that this is the current edition of standardised colours, e.g. *NCS S 3000-N* or *NCS S 2502-Y*.

Notations given by comparing colours with an NCS Index or using a scanning device may not necessarily show the *exact* colour match needed for reproduction but may provide enough information for the purpose of identification of “colour attributes” or “colour areas”. However, the

NCS system affords colour specification outside the standardised colour range, giving the possibility of more accurate colour references than the nearest standardised colour. Unstandardised colours are denoted without the capital “S” in front of the colour notation, for example *NCS 2903-G36Y* or *NCS 2703-Y*.

The standard colours of NCS 1950 have proved sufficient in identifying more saturated, chromatic colours for Trondheim, but insufficient for determining the “neutral” colours. “Achromatic” means “without colour”, thus stating that there is no hue, only blackness and whiteness (greyscale). In the NCS system this is denoted with a N (neutral) after the nuance notation, e.g. NCS S 3000-N (30% blackness, 0% chromaticness, and 70% whiteness).

When registering the “neutral” colours using NCS 1950, one is limited to nineteen (19) achromatic colours in the greyscale between NCS S 0300-N and NCS S 9000-N. The next, chromatic level are the sixty-four (64) nuances with 2% chromaticness, before the next chromatic level of 5% chromaticness (but for a few exceptions in yellowish, white hues), giving a total of approximately ninety (90) colours in the range of achromatic to near-achromatic colours.

## RESEARCH

In the identification of façade neutrals, we have compared the registered NCS 1950 colour notations with pigments and pigment compositions used in traditional paint and examined the colour reference material used by local architects and the Cultural Heritage Office in Trondheim (products and tools). The research was restricted to traditional building materials and pigments used in production of traditional façade neutrals and, and to research of products and colour swatches of traditional façade neutrals for wood and rendered facades currently on the market.

### Nominal and perceived façade neutrals

Research on nominal and perceived façade colours shows that achromatic colours in exteriors are generally perceived as slightly purplish blue colours, in hues between R70B – R80B (Fridell Anter 2000: 225-227). As colours in architectural context are mostly attributed by their perceived quality, one could argue that these colours can no longer be considered as achromatic colours when used on façades. In Trondheim, another argument would be that hues with more redness than R80B are outside the colour palette, and thus breaking the overall colour gestalt. Even if the perceived colour has a hue of R80B, i.e. being within the colour palette, it is perceived and considered as a blue hue. In Trondheim, where blue hues were traditionally very rare, it is recommended that blue façades are to be used rarely.

### Colours in Norwegian cultural heritage practice

Colour in architecture is, and has always been, a result of available pigments and building materials. Today, manufacturers offer traditional paints and pigments presented as colour swatches, usually referred to with production numbers or associated colour names to indicate visual colour attributes. Product specification of pigment compositions are often provided, and occasionally even NCS notations as additional colour reference —either as exact, unstandardised NCS notations or as the nearest NCS 1950 notations. In our research, colour swatches without provided NCS notations were scanned using NCS Colourpin II (NCS 1950). Exact matches always showed unstandardised NCS notations in a wide range of chromatic colours and never achromatic. Colours given as the nearest

NCS 1950 showed both chromatic and achromatic NCS notations (Figure 2, orange dots indicate chromatic matches and blue dots indicate achromatic matches).



Figure 2: From left: Colour appearance key for “bone black” and “iron oxide black” when mixed with white (kulturkulör). NCS diagram showing hues and nuances of traditional colour swatches.

### Inherent colours of traditional façade materials

Traditional architectural façade colours are either the inherent colour of the façade material or applied colours. The traditional materials in Trondheim were restricted to available resources, i.e. wood, stone and brick, and most of these façade materials were painted, either in need for surface treatment or to imitate fashionable façade materials of quality stone or brick. Registrations of both the inherent and the applied colours showed a variation of chromatic notations (NCS 1950), but for a few achromatic notations (NCS 1950), similar to the NCS diagram in Figure 2.

### Traditional pigment composition of façade neutrals

“In its simplest form, paint is a liquid that is applied to a surface and converts to solid film. It is most commonly used to protect and decorate an object and is composed of the colouring matter known as pigment, a vehicle to carry it, known as the medium or binder, and the diluent or solvent, added to make it flow” (Baty 2017: 28-67).

In Trondheim, the traditional paints used oil binders for wood cladding and water-based binders for rendered façades. As a port city, there were quite a few imported pigments available on the market, but most exterior paints used locally sourced pigments to keep the cost down. For exterior paints to be functional, affordable and durable, pigments used in façade neutrals had to meet specific criteria, i.e. *cost*, *availability*, *opacity*, *lightfastness* and *ability to dry*. Black colours were unpractical, as they dried too slowly, and pure white pigments were extremely costly, and rarely used in large quantities.

Traditional black pigments were mostly variations of carbon black, i.e. charred wood —locally; charred fir called “kjønørk”— and iron oxide black, all with a blueish black appearance. Traditional white pigments were chalk, lead white, zinc white and titan white. When mixed, black and white pigments produced neutral colours with blueish hues, often referred to as “cold greys”.

More commonly used pigment compositions for façade neutrals were different combinations of ochre mixed with “kjønørk” (carbon black), raw umber or green umber, producing variations of colours, i.e. “neutrals”, “warm” and “cold” greys. All these pigments and combinations, except lead white, are still in use today, and when mixed they produce greys and neutrals in variations of chromatic hues and nuances, but they are never achromatic when examining the exact NCS notations or the colour appearance keys (Figure 2).

Technically, the only traditional façade colour that has a probable possibility for being achromatic is white pigment mixed in water-based binders. Oil binders always added a yellowish hue to white paints for wood but rendered façade colours had the possibility to be completely without hue, if the pigment quality were completely opaque not let the inherent colour of the building material add to the perceived colour. However, this would be an extremely costly production and has not been registered in our project in Trondheim.

### Traditional colour theories and modern colorimetry

Traditional colours and colour theories were generally based on available pigments, as seen in the RYB colour model used by Goethe (1749-1832) and Itten (1888-1967). In modern colorimetry RYB is regarded as an outdated colour model, as it cannot produce pure complementary colours (achromatic white, black or grey). At the time, it was not possible to produce colours such as magenta and cyan, colours fundamental in modern colorimetry, i.e. RGB and CMYK, and colours necessary for achieving pure complementary colours (Figure 3).

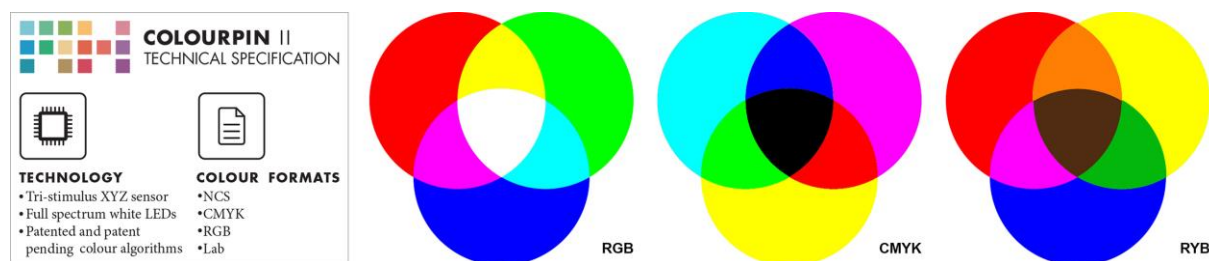

Figure 3: Left: Technical specification of NCS Colourpin II. Right: Colour models RGB, CMYK and RYB.

## RESULTS AND DISCUSSION

When examining nominal colours of the materials and paints used in traditional architecture, it is clear that inherent and applied colours were not achromatic, and that traditional neutrals always had a chromatic content, often referred to as “neutrals” or “cold” or “warm” greys. Architectural colours are based on available pigments and practical production, but modern digital tools are in general based on tristimulus colorimetry and colour models, i.e. RGB.

Standardisation has possibilities to be both a positive and a negative contribution to architectural practice but will always be restrictive. When the aim is colour accuracy, relying on approximately two thousand (2000) colours to represent potentially millions of hues and nuances requires careful reflection on what is gained and what is lost in the process.

The research described in this paper used an updated NCS Colourpin II, including RAL colour notations and their equivalents in exact, unstandardised NCS notations. These colours added approximately fifty (50) “neutral” colours to previous NCS 1950, i.e. approximately 50% increase in determining colour accuracy of neutral façade colours (Figure 4).

When using the NCS Colourpin II, the possibility for visual comparison between the measured colour (HEX coordinates) and approximate colour matches (NCS 1950 and RAL) has proven invaluable for the purpose of more “accurate” identification of colour attributes, and that the “accuracy” should be defined by visual identification of significant colour attributes rather than by modern colorimetry.

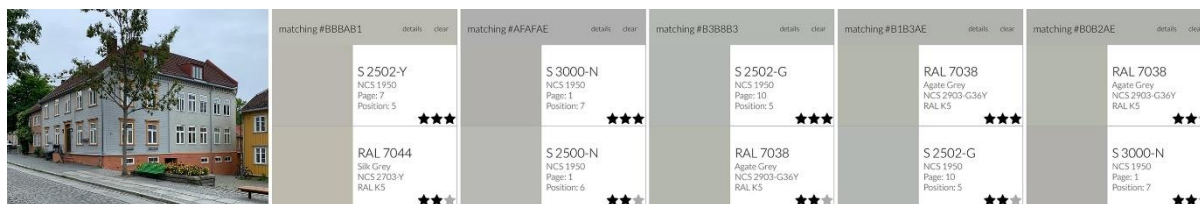

Figure 4: Screen shots of scan results using NCS Colourpin II, showing HEX coordinates and the approximate nearest NCS 1950 and RAL notations when scanning different sections of a façade wall of a building in Trondheim.

## CONCLUSION

When using modern colour reference systems and tools based on modern colorimetry to determine traditional colour specifications, we should always consider that the colour range available at the time of production was based on available pigments. Pigment compositions used to produce functional, affordable and durable façade paint did not allow for achromatic colours.

We propose the rule of thumbs to be that all traditional colours has a significant, chromatic hue, however small. We strongly suggest all manufacturers of traditional paints and products never to provide achromatic colour references, that traditional façade colours were not achromatic and always had a hue with a chromaticity higher than zero;  $C > 0$ .

## ACKNOWLEDGEMENTS

The project is supported by the Trondheim Municipality, with a special mention of Mette Bye, Marte Osvoll Valderaune and Bente Egeland. The authors would like to pay particular acknowledgment to Karin Fridell Anter, whose research on exterior colour, and dissemination of the use of the NCS as an analysis tool, this paper builds on.

## REFERENCES

- Angelo, K., and A. Booker. 2016. Perceived colour and colour perception. In: *AIC 2016 Interim Meeting "Color in Urban Life: Images, Objects and Spaces"*, Book of Proceedings, Santiago de Chile, 18-22 October 2016, I. Calvo Ivanovic, ed. Santiago de Chile: Asociación Chilena del Color, 74-77.
- . 2018.  $S > C$  – Proposing a formula for harmonic urban colour composition. In: *Proceedings of the International Colour Association (AIC) Conference 2018*, Lisbon, 25-29 September 2018, M. Gamito and M. J. Durão, eds. Newtown, NSW: International Colour Association, 59-64.
- Baty, P. 2017. *Anatomy of colour*. London: Thames & Hudson.
- Fridell Anter, K. 2000. *What colour is the red house? Perceived colour of painted facades*. Stockholm: Royal Institute of Technology, Institution of Architecture, Department of Architectural Forms, doctoral dissertation.

## **Clorindia domestica. Studies of architectural chromatic organization in relation to landscape**

**Juana Gandino\*, Rocío Melman, Ludmila J. Paroldi Algranati,  
José Luis Caivano, Gabriela Cárdenas, Roberto Lombardi**

Universidad de Buenos Aires, Facultad de Arquitectura, Diseño y Urbanismo,  
Programa de Investigación Color, Buenos Aires, Argentina

\* gandinojuana@gmail.com

### **ABSTRACT**

This paper focuses on single-family houses made by architect Clorindo Testa in cooperation with Juan Fontana, Eduardo Bompadre, Elena Acquarone, Juan Genoud and Ezequiel Rivarola. These cases stand out due to their condition of free perimeter houses, built in suburban areas or immersed in natural landscapes. In this research, we plot differences between inherent and perceived color. By unfolding the exterior envelope of the building we can recognize the relation between color, external configuration and morphology. Chromatic diversities are produced due to the incidence of light and the self shadows, even when we are dealing with painted houses with a dominant inherent color (reason why the houses are called “Green house”, “White house”, etc.). The analysis makes special emphasis on the landscape and reflects on how color works as an organizer, not only of the elements in the house but also of the architecture and its context. The functions of color can be defined as abstract-generic and perceptual-contingent. It can be perceived how the colors of the houses and landscapes constitute integral palettes which selectively manage contrasts and mergers. The research is based on architectural drawings and photographs from a period of Testa’s work dominated by the use of outside and inside painted surfaces. We have developed a system that offers a global synchronic perception of chromatic relations, in order to simultaneously show what would otherwise require a tour around the building in a temporal-spatial sequence. This method gives the possibility to compare the cases under study and to identify systematic operations of color in relation to morphology, allowing us to recognize some operative consistencies.

**Keywords:** *architecture, chromatic organization, inherent & perceived color, representation system, landscape*

## INTRODUCTION

This paper, framed in the research project “Clorindia domestica” (Lombardi chair 2012), develops the analysis of chromatic procedures of one of the most famous Argentine architects, Clorindo Testa (born 1923 – died 2013). His style as an architect has always been influenced by the rationalist and brutalist movements in which he stood out. Most of his works and projects are dominated by the effects of color, tension, morphology and plasticity. In this research, we focused on a selection of cases taken from a larger set of single-family houses made in cooperation with Juan Fontana, Eduardo Bompadre, Elena Acquarone, Juan Genoud and Ezequiel Rivarola between 1984 and 2011. These cases stand out due to their condition of free perimeter houses, built in suburban areas or immersed in natural landscapes, from a period of Testa’s work dominated by the use of outside and inside painted surfaces.

In the same way, the research itself develops a comparative method in order to understand different relations between house and landscape. Furthermore, it generates a comparison of the houses through a series of synchronous images-synthesis, which result from drawing colored projections of all facades and the surrounding landscape.

Understanding Clorindo Testa’s work, also implies understanding its morphological condition in relation to color. His domestic work demonstrates certain constants in its procedures, allowing to generate a chromatic and morphological identity. Each case presents its own logic generated by particular behaviors: stereometric-volumetric and topological features in relation to the landscape, manifesting surface continuities and discontinuities.

## THEORY

This research employs the concepts of inherent color and perceived color that have been proposed by Karin Fridell Anter (1997, 2000). The perceived color is what we see in a specific situation, and varies according to lighting conditions, surrounding colors, distance and angle of observation. The inherent color is the color of an object or surface, measured or observed under standardized conditions, for example by comparison with reference chromatic samples supported directly on the surface (whereby the lighting and observation conditions are identical for the surface to be measured and for the reference sample).

Fridell Anter (2000: 24) uses the inherent color as the reference color, from which the changes of the perceived color on the surfaces are compared. In this way the inherent color does not represent the ‘real color’ of an object but rather a ‘nominal color’.

## METHOD OF REPRESENTATION

In order to analyze the houses, we developed a method of representation based on unfolding their surfaces. This format allows to study the chromatic treatment used, taking the information from architectural drawings and published photographs. The aim is to build a global synchronic perception of chromatic relations, in order to simultaneously show what would otherwise require walking around the building in a temporal-spatial sequence.

The method of representation consists of:

- Selecting two relevant photographs from outside which evidence the relation between the house and the landscape.

- Selecting two interior photographs showing iconic places of the house in relation to color.
- Unfolding the exterior surface (and some interior ones) to study a topological behavior of color, that deals with surface continuities and discontinuities between different elements and relative positions in space.
- Associating the exterior unfolded facades with some interior surfaces, incorporating (as a kind of graphic “comments”) relevant details that do not appear in the photographs. This composition is not casual or automatic; the intention is to associate faces that are feasible to be connected.
- Applying the inherent color on the surfaces under full direct lighting, according to the photograph chosen as reference.
- Defining the surfaces by their perceived colors, without drawing boundary lines. The edges between surfaces are generated by the change of color, as it is natural in visual perception.
- Applying the perceived color depending on the light received by each surface, according to its orientation, for the chosen illumination.
- Representing the self shadows, not the cast shadows.
- Placing the house in relation to the inherent colors of the landscape.

The graphic work and the method of representation begin with the transformation from the three-dimensional building to a two-dimensional image. Thus, by unfolding the exterior facades, a panoramic vision is generated, expressing the volumetric features and simultaneously exhibiting all the exterior details of the building in its true length. This procedure evidences the careful association between the colors of the building and those of the landscape (Figure 1).

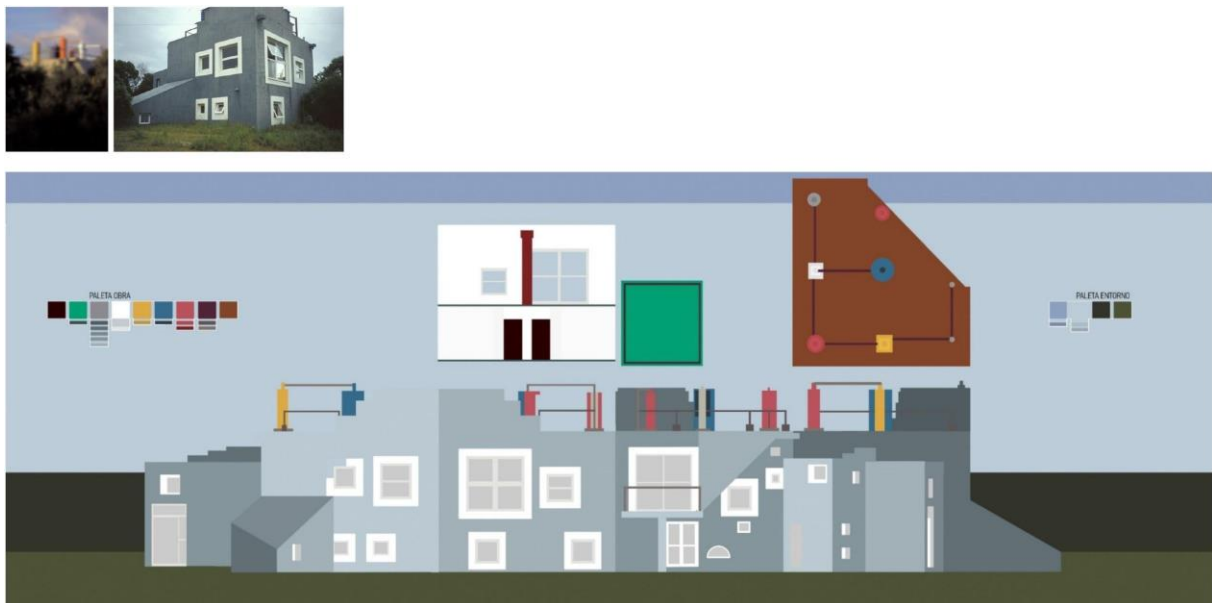

Figure 1: Photographs and unfolded representation. Capotesta house.

### ELABORATION OF COLOR PALETTES

The analysis creates color palettes that show the variations between inherent and perceived colors, took from the reference photographs.



The procedure includes:

- Posterizing the images (level 8 in Photoshop) to highlight the pixels and obtain more representative color samples.
- Extracting a selection of colors to create two base palettes for each photograph, one of the colors under direct lighting, and the other under diffuse lighting.
- Creating a synthesis palette which integrates both base palettes.
- Incorporating the palettes to the final drawing (Figure 2).

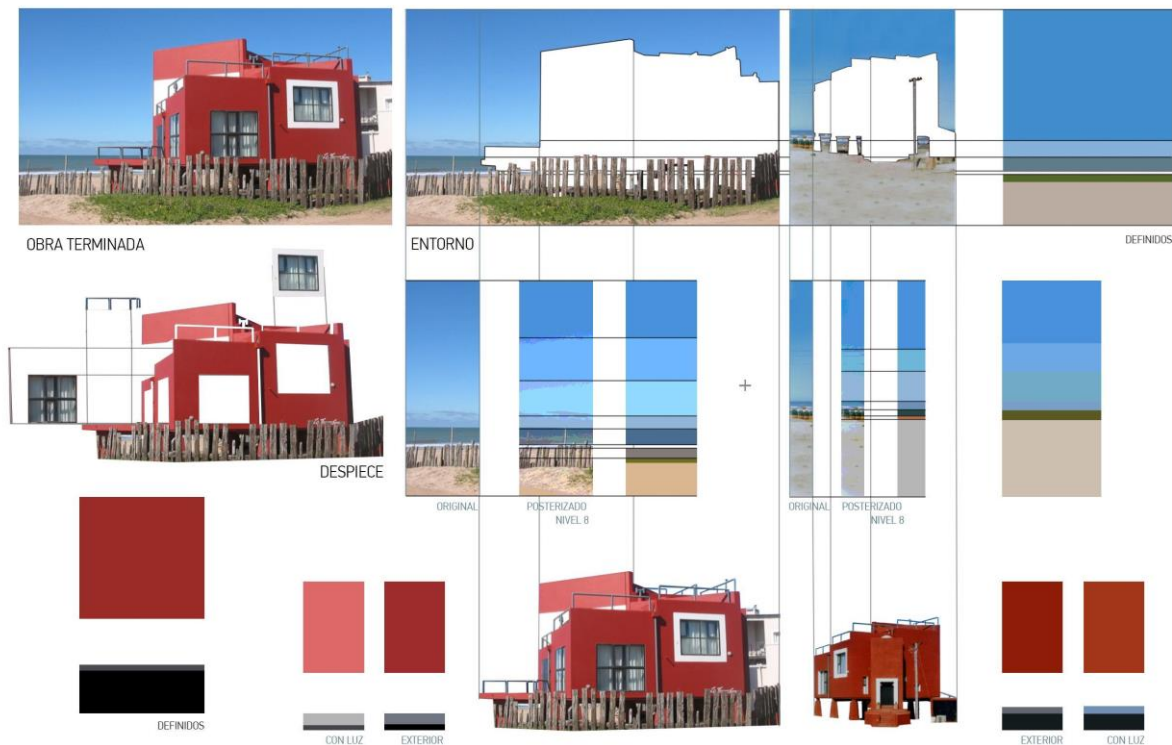

Figure 2: Elaboration of color palettes. La Tumbona house.

## RESULTS AND DISCUSSION

Color operates as an instrument of design that organizes relations between elements of the project. The material behavior is not fixed to the "natural" expression of technology, but appears drastically expressed intentionally by the use of finishing paints.

Dominant and secondary colors can be identified in all the projects, and a variable number (between none and many) of accents or linear colors are also discovered on carpentry, railings, and distinctive elements (Figure 3).

Thus, the exterior configuration of the houses manifests the chromatic diversity produced by the incidence of light and the self shadows, even when it comes to buildings painted with a dominant color (to the point that their names on the publications frequently appear as "Green house", "White house", etc.).

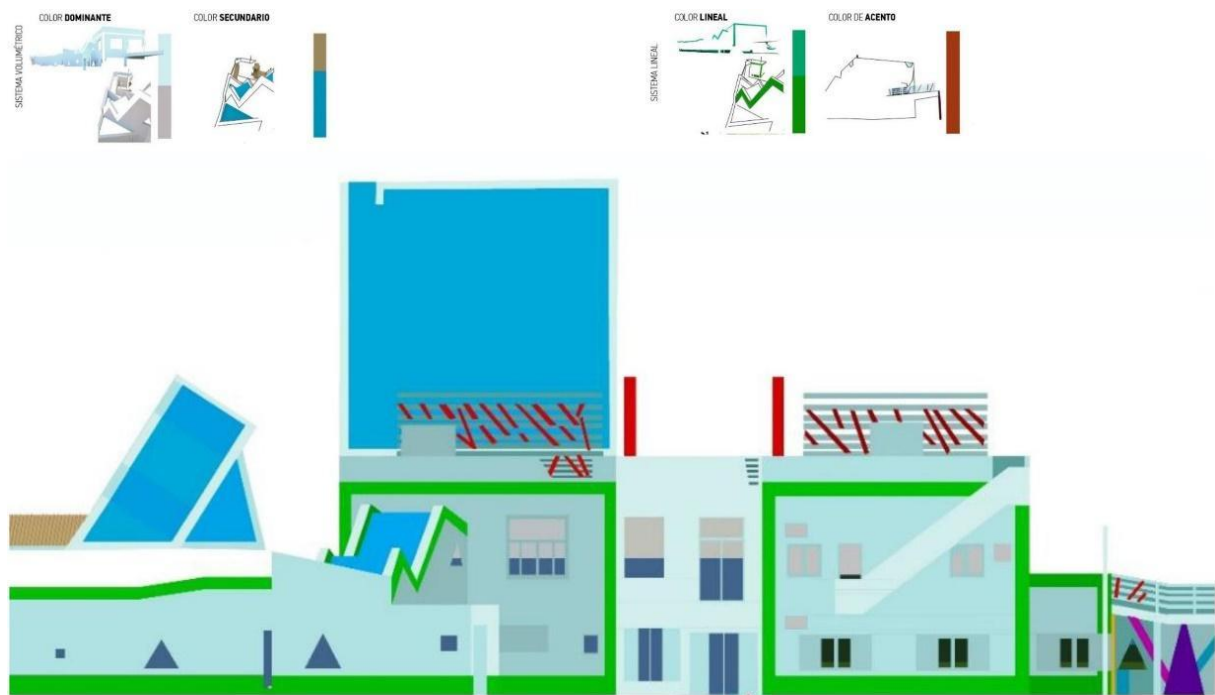

Figure 3: Chromatic analysis. Fragment of the unfolded representation. House in La Pedrera.

The history of architecture and landscape reveals three basic models of relations between them: contrast, merger, and reciprocity. Usually, they do not appear in pure form, but one of them often predominates, in combination with one or both of the others. These combinations not only enhance the appearance of the house but also allow it to embody a rich complexity of meaning.

Contrast is often employed understanding nature as a realm apart, with its own characteristics that differ from the work of art. Merger is the polar opposite of contrast. Here, a building is made to appear as an integral part of its natural or cultural landscape. In a natural landscape, the form (or color) of the building may reflect the surrounding topography and colors. In its pure form, merger is never possible, because the very act of building obviously introduces an element of contrast in a natural landscape. However, merger is emblematic of the human capacity for harmonious adjustment to nature (Rainey 1988).

In Testa's work we can find a variety of examples of these different relations between architecture and landscape. La Tumbona house is a great example of a contrast predominance. It makes a counterpoint with the immediate environment by two main features: 1) the elevation of the house, pulling it away from the sand; 2) the burgundy paint that covers the exterior walls of the house and stands out against the light blue background. The house appears as an object intentionally separated from its environment. The Green house, instead, can be used as an example of merging. The color of the walls is blended with the trees, while the roofs seek to merge with the sky (Figure 4).

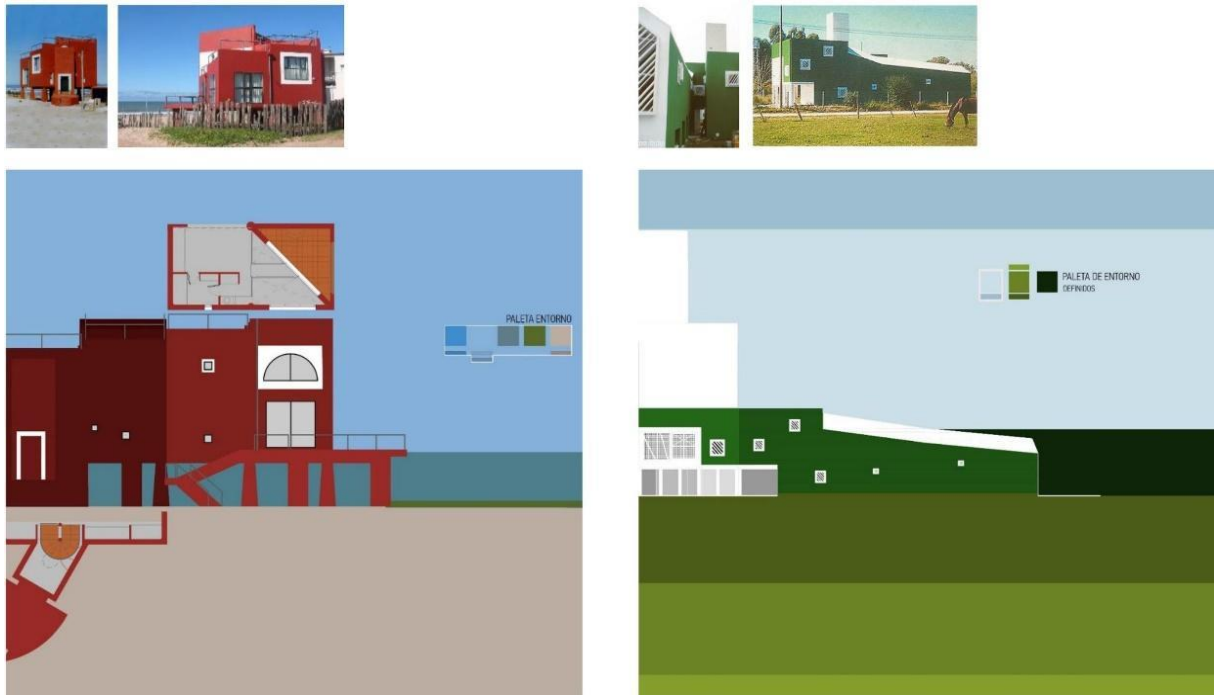

Figure 4: Photographs and fragments of the unfolded representations. La Tumbona house (left) and the Green house (right).

## CONCLUSION

Concepts, methods and tools are established to understand the aspects of color and visual appearance in the domestic architecture of Clorindo Testa. They allow to make a comparison between the cases studied and identify systematic operations of color in relation to form, recognizing some operational consistencies in the works studied.

The formal singularity of this series of Testa's works, normally identified with spatial-volumetric organization systems and abstract operations of addition and subtraction, can now be updated in the key of the color behaviors, especially from superficial and contextual continuities, to redefine its strategic spatial model towards less schematic forms.

We propose to value them not only for their macroscopic and generic behaviors but also for their multiple local intelligences, capable of generating singular relations that expand and multiply the consistency of design procedures.

The analysis represented as image synthesis is systematized to compare the cases with each other in a scientific approach. It aspires to function as a trigger of new reflections, highlighting relations through a synthetic construction and representation that allows us to continue developing not only the method itself, but also the knowledge of the projects themselves (Figure 5).

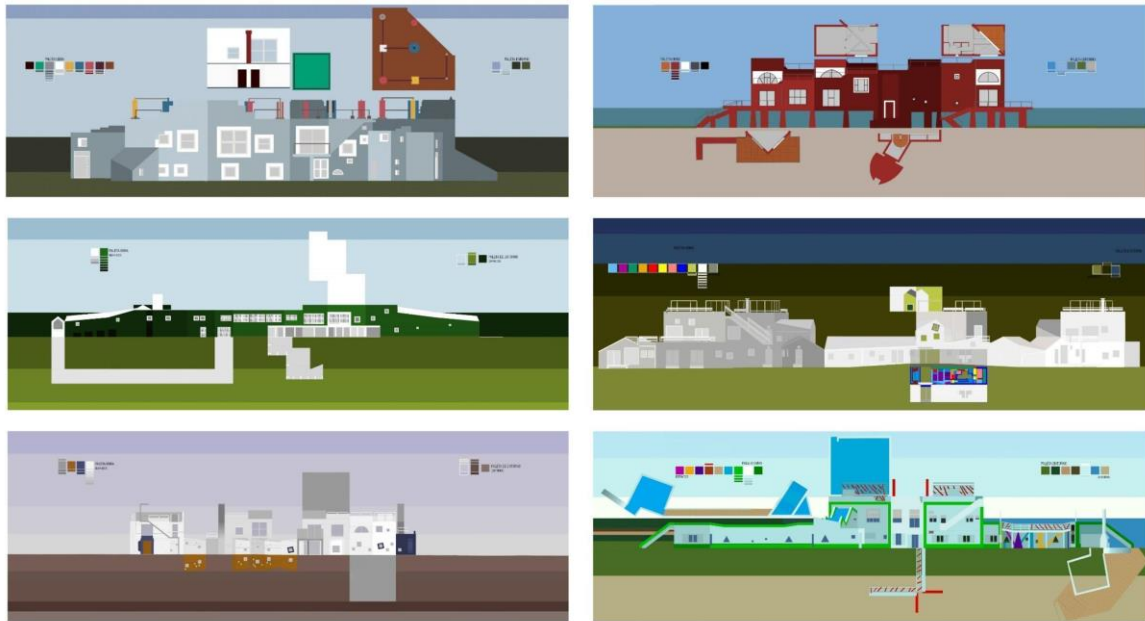

Figure 5: Graphic synthesis.

## ACKNOWLEDGEMENTS

This work is framed in the project “Clorindia domestica” directed by Roberto Lombardi in the context of the Morphology courses, at the School of Architecture, supported by the University of Buenos Aires under the research project 20020170100757BA (2018 to 2020), directed by José Luis Caivano.

## REFERENCES

- Fridell Anter, K. 1997. Inherent and perceived colour in exterior architecture. In: *AIC Color 97, Proceedings of the 8th Congress of the International Color Association, Kyoto, Japan, 25-30 May 1997*, vol. 2. Kyoto: Color Science Association of Japan, 897-900.
- . 2000. *What colour is the red house? Perceived colour of painted facades*. Stockholm: Royal Institute of Technology, Institution of Architecture, Department of Architectural Forms, doctoral dissertation.
- Lombardi chair. 2012. Clorindia doméstica. Database developed by Roberto Lombardi chair, FADU-UBA. Online: <http://clorindiadomestica.blogspot.com>.
- Rainey, R. M. 1988 Architecture and landscape: Three modes of relationship [The Inhabited Landscape: An Exhibition]. *Places* 4 (4). Online: <https://escholarship.org/uc/item/47k9b2mm>.

# Colour in relation – Relations between the perception and design of architectural surface and its context

Martin Huwiler\*, Cornelia Gassler

Lucerne University of Applied Sciences and Arts, Lucerne, Switzerland

\* martin.huwiler@hslu.ch

## ABSTRACT

The exploration of design relevant questions about the colour quality of architectural surfaces in complex interaction with their correlating context forms the heart of this paper. Colour is considered in its material qualities and therefore as interacting with and being influenced by the material world. Different colour appearances are elaborated as variables in the application processes, in the lifecycle process and in the perception of the building and its environment. Based on an applied research project, we draw a comparison with a field chapel built between 2005 and 2007 in Wachendorf, Germany, by the architect Peter Zumthor to expose relations of colour and its context from a design-driven perspective. The aim is to understand the qualitative aspects of coloured surfaces in order to cultivate diversity in the built environment. Aspects of the atmosphere, which are scientifically difficult to evaluate are discussed in the awareness of their complexity depending on the viewers reception.

**Keywords:** *architectural surface, colour, diversity, embodied knowledge, atmosphere*

## INTRODUCTION

Colour is material: granular, mineral, finely pulverized, rubbed into the binder, synthetic, glossy, pasty or translucent has an origin, history, requires specific processing and it ages. In these temporal sequences, colour is shaped by various changes and transformations, which we all define as part of the context. The context in a non-dynamic sense, but in the current time segment ranges from the user's embodied experience of the surface effect, the architecture and the landscape. Relations between colour and context on facades were first examined in the applied research project "EVDH - Extended processes for plaster surfaces: synergies between digitality & craft" (EVDH).

Material samples resulting from a series of experiments flank the observations on material qualities in different light situations and different viewpoints, changes caused by environmental influences and the diversity of different application processes. The research project was experiment-driven and based on three research fields: material, tool and craftsmanship. The focus of the project

was on the research and evaluation of digital hand tools for structuring plaster surfaces with the aim of generating diversity in the surface but also in the built environment out of a novel production process. It became clear that colour was an inseparable part of this research field. The theory derived from the project already contains partial aspects on colour and its relations and is more precisely outlined by Peter Zumthor based on the finished project in Wachendorf and thus leads to the desired holistic discussion.

Due to the methodological approach, which was strongly influenced by hands-on experiments, design relevant observations could be made which would not have been possible by pure conception. In other words, the insights are not only based on distancing reflections but also on embodied knowledge. An essential question accompanied us and led us to this theoretical discussion: Which aspects are relevant for the embodied experience of architectural surface in a relational, atmosphere - orientated design? The insights pertaining to design and the relations between colour and context are discussed and elaborated by means of a case study on the field chapel by Peter Zumthor, dedicated to Saint Niklaus von Flüe, paying special attention to colour as a material and its context.

The building serves as a best case for an implementation as it demonstrates how design solutions are able to embrace and incorporate traces from the building process and the material surroundings of a building. From the observations of the art historian Monika Wagner, it becomes apparent that colour material was repeatedly reduced to the tone of colour. Its body, materiality, own dynamics within a relational whole were pushed into the background to imitate and allude other materials, but also to strengthen a symbolic, ideal form (cf. Wagner 2002: 17-55). This abstraction of colour is to be countered by reflections on a relational design attitude as described by Witzgall and, based on Gernot Böhme, Juhani Pallasmaa and Peter Zumthor himself, enriched with aspects of an atmosphere - oriented design. This paper elaborates theoretical aspects for relational design and provides a glimpse into how to modulate and cultivate a colour design in a complex way forming a complete spectrum.

## DISCUSSION

The paper attempts to show that the whole is more than the sum of its parts and therefore focuses on the relations. Placing relations in the centre of an argumentation can be observed in currents of the New Materialism. Susanne Witzgall, who vividly discusses the various currents of new materialism, cites theories by Brian Massumi or Karen Barad as convincing, because they both refer to the *in-between* and *relations* between entities. A paradigm shift takes place, where thinking in isolated categories and concepts is overcome and “relations are understood as the primordial cause of existence” (Witzgall 2016: 101; translation from German by the authors). Witzgall establishes *relational design* as an open design attitude in which the designer consciously pays attention to the participation and power of (human and non-human) entities in the design process (Witzgall 2016: 115). The participation of dirt as an exemplary non-human entity was experimentally simulated in the project EVDH. The self-dynamic and natural deposition of dirt over time leaves different colour intensities on the sample and accentuates the vertical lines of the structure (Figure 1). This leads us first to insights into the design power of non-human entities, followed by a user-centered perspective in which the user as a human entity and processual perception are in focus.

### Perspective of the context (non-human entities)

Light continuously changes the colour effect during the course of the day. It leaves the colour in the shade or illuminates it completely, even lets it fade over time or makes the materiality stand out in the oblique light. This self-dynamic moments or aspects of *brainless regulations* are defining elements of the design and can be consciously considered and involved as designing actors.



Figure 1: Material sample for simulation of dirt deposit.

Figures 2, 3: Visualization direction-dependent colour effect.

Brainless Regulations short BR is a term formed by us, which summarizes the following contents: BR is a principle that stands for undetermined aspects within planned structures. This means that a part of a design process is not subject to planning, but to chance, to aspects of material or time to self-regulation or to a partly opened production processes. As mentioned above also the deposition of dirt is not regulated or determined and is deliberately left to the complex laws and interactions of nature and thus stores time aspects of the change in the surface. BR independently generate small deviations, imprecisions and variables in the colour composition. They lead to a higher diversity and liveliness supporting the readability of material and storing production processes. Elizabeth Shotton made interesting trains of thought on material imprecisions, saying that a “relinquishing of control as it relates to processes and the abandoning of influence over final interpretations, could be the means to create this quality of transient fragility, by placing the reading of the artifact beyond the simplicity of the narrative - imbuing it instead with an evocative ambiguity in terms of both material rendering and its ultimate meaning” (Shotton 2007: 93). In contrast to a controlled or reduced surface, BR lead to a quality of colour and texture with not only a high diversity and complexity but also ambiguity for the observer. They increase the openness in the interpretation with all aspects that are a basis for the creation of atmosphere and which are described later along Peter Zumthor’s project in Wachendorf.

### Perspective of the user (human entities)

From a distance, the shadows and lights of a surface structure become mixed to an almost uniform colour shade and as described in the section above, this colour shade is depending on the position of

the sun and becomes brighter or darker. The closer one comes, the differentiations in shadows and lights can be more and more perceived. This increases diversity in the process of perception of the facade. Regarding the design of surfaces, the term *diversity* originally refers to David Pye.

In his sense it describes a quality that derives from craftsmanship: the fine pattern of tool marks and the deviation from a smooth surface or a straight edge (Pye 1968: 35). The architect Uli Herres adds that diversity can be understood as a formal property of an object, which describes the sum of visual details as they are created by traces of craftsmanship, but also by ageing and by material properties such as wood grain (Herres 2016: 202). In other words, it describes the presence of differences and material based microstructures. Diversity in our expanded sense also means solutions whose interpretation includes and cultivates a multi-layered perception as in the example of proximity/distance mentioned above. For years, the architectural historian Walfried Pohl has been committed to ensuring that microstructures and ornaments that become interesting at second glance, must be increasingly cultivated in architecture. Through modern reduction or even the avoidance of microstructures, a monotony arises that no longer corresponds to the human being and his need for stimuli (cf. Pohl 2010: 150).

On another exemplary facade sample, there is a structure drawn through the plaster with a template with triangular peaks (see Figures 2, 3). In one direction, the structure is sprayed in an blue colour that correlates with the blue sky. And in the other direction with a colour related to the forest. A direction-dependent colour effect is created. As you walk by, you can see from one side above all the blue hue and from the other side a colour nuance of the forest. But not only by physically moving towards a building or walking by, a change of perspective can happen.

It might be that we realize, that the facade and the tree in autumn have a related colour and suddenly an association is formed. The colour and surface as such enable the viewer to establish a relation in the process of perception. This creation of relations and, in a certain sense, of an identity forming order is to be understood not only as conscious perception, but also as an unconscious stimulation of the senses. Humans experience the built environment with all their senses and their embodied knowledge (cf. Pallasmaa 2013). Zumthor describes it quite simply: “People interact with objects. As an architect that is what I deal with all the time” (Zumthor 2006: 11). And Böhme describes the human as “the sounding board for architectural quality” and then provides a definition of what atmosphere is: “And what between both (namely corporeal state and the qualities of the space I am in) is acting as an intermediary —that is the atmosphere” (Böhme 2014). Zumthor and Pallasmaa in particular deal intensively with the topic of *embodied knowledge*. What does architecture and landscape show through the body or all our senses?

How is the interaction of the partial aspects to be designed and how does atmosphere arise from it? Colour, material, light, space in the overall sensitive perception of the interacting human being. “It is this haptic sense of being in the world, and in a specific place and moment, the actuality of existence, that is the essence of atmosphere” (Pallasmaa, in Böhme 2014).

The Bruder Klaus field chapel can be cited as a best case of a built implementation to discuss the evolved contents. The chapel allows to reflect, how Peter Zumthor composed colour and material or light and shadow within spatial structures into a relational whole. One aspect he mentions in his publication *Atmospheres is material compatibility*: “I take a certain amount of oak and a different amount of tufa, and then add something else: three grams of silver, a key – anything else you’d like? [...] And we would look and see how these things react together. And we all know there would be a reaction. Materials react with one another and have their radiance, so that the material composition gives rise to something unique” (Zumthor 2006: 23-24).





Figure 4: Bruder Klaus field chapel from outside.



Figure 5: Bee wax candle in front of the soot coloured surface.

He designs out of a relational understanding, knowing that only through a specifically modulated entanglement of the different aspects the whole can be brought to sound and thus have a harmonious effect on the viewer touching him emotionally.

The elementary dimensions of fire and water, earth and sky are each called upon and made present in their own way. [...] In any case, the fire remains permanently present in the burnt-out, sooty hollow form of the building. The humidity of the water standing in the ground puddle, the noises of the dripping rain, the crunching of the foot on the ground and the wind that sweeps across the opening of the chapel and continuously fills the room with a slight noise are just as much part of the physical-haptic experience that Zumthor offers visitors with his holistically designed building as the metaphorically understood “warmth” and “sound of the room” that feeds on the materials that come to bear in it. (Hubert 2016: 62; translation from German by the authors)

In the design of the Bruder Klaus field chapel it seems clear that Zumthor worked with "Material Compatibility" and created specific colour material qualities with the intention of cultivating atmospheres. As formwork for the interior, he used local spruce trunks which he built up into a tent-like structure and burned out after the tamped concrete set. From this processual act the dark colour, rich in nuances emerges. You see the layers of tamped concrete and the surface texture of the trees (Figure 5). The traces of the production processes show “a condition captured in stasis as an embodiment of experience and a memory of its other nature” (Shotton 2007: 92). Due to the implementation of BR the diversity increases in a natural, uncontrolled way. The colour is not symbolic, but functions in a multi-layered superimposition. It enables a multi-layered legibility and an open scope of interpretation for the visitor.

The interior of the chapel is illuminated with daylight through a small opening in the ceiling and supplemented with beeswax candles. It is not only stimulating the virtual sense, but brings the scents of the weather together with the scent of the bee wax and blends with the scent of the colour giving soot. From outside, the tamped concrete, which is mixed with the local soil of the field, acts as an identity-forming connection with the colour of the surroundings. These individual impressions of the chapel weave themselves into an atmosphere that enables an emotional and embodied experience.

## CONCLUSION

Our discussion in the research project EDVH led us to distinguish our views and extend our perceptions. These coherences will be further developed in our theory in the future. Zumthor's chapel was then portrayed as man-made, experienceable architecture with all its nuances.

These are our insights:

Synergy between human and non-human entities —BR in processes— is the basis to create complex aspects and to increase the openness of the user's interpretation. Diversity or complexity in design that appeals to all senses is the prerequisite for the integration of embodied knowledge and thus the roots to generate atmospheric mood.

The main issues from the discussion are summarized:

- Composition of the aspects regarding to atmospheres: the whole is more than the sum of its parts
- Creating diversity and complexity: generate ambiguity
- Inclusion of non-human entities: brainless regulations
- Inclusion of non-visual aspects: embodied experience
- Interweaving with the context: relational design

It becomes clear that colour only unfolds its full atmospheric potential in relation and resonance, as a complex composition. In this way, the colour design cannot be argued outside the system as pure abstraction. What can be added in terms of our perception here is that the materiality and quality of colour in its complex wholeness must be placed and designed on the same level as the space. The space is transformed from a geometric to a complex, frayed space through the processing and interaction with materiality, i.e. from the point of perspective of the space, the transitions are not Euclidean and smooth but rough in their aspects. The recent aspects of emotions are not flat, its complexity and non-human entities forms the dreams of atmospheres.

## ACKNOWLEDGEMENTS

The research which has led to this paper was funded by the Swiss Government (Innosuisse) and conducted by the transdisciplinary theme platform Materialität@hslu at Lucerne University of Applied Sciences and Arts, Department Art and Design, Department Engineering and Architecture.

<https://www.hslu.ch/en/lucerne-school-of-art-and-design/research/labor-materialitaet-und-ressourcen/>.

## REFERENCES

- Böhme, G. 2014. *Encountering atmospheres*. Online: <https://www.archined.nl/2014/04/encountering-atmospheres-a-reflection-on-the-concept-of-atmosphere-in-the-work-of-juhani-pallasmaa-and-peter-zumthor/>.
- Herres, U. 2016. *Spuren des Handwerks - Der Einfluss handwerklicher Herstellung auf die Architektur*. Zürich: ETH.
- Hubert, H. W. 2016. *Annäherung an einen Muße-Ort: Die Feldkapelle Bruder-Klaus von Peter Zumthor*. Online: <https://doi.org/10.6094/musse-magazin/2.2016.57>.

- Pallasmaa, J., A. Wutz, and S. Holl. 2013. *Die Augen der Haut: Architektur und die Sinne*, 2nd revised ed. Los Angeles: Atara Press.
- Pohl, W. 2010. *Der zweite Blick –wann ist er wichtiger als der erste? Gliederungsprobleme in Architektur und Design*. Essen: Klartext.
- Pye, D. 1968. *The nature and art of workmanship*. Cambridge, UK: Cambridge University Press.
- Shotton, E. 2007. Material imprecision. In: *Material matters: architecture and material practice*, K. Lloyd Thomas, ed. London: Routledge.
- Wagner, M. 2002. *Das Material der Kunst: eine andere Geschichte der Moderne*. Munich: Beck.
- Witzgall, S. 2016. Immanente Relationen –Von der Handlungsmacht der Dinge zur nicht-repräsentationalistischen Kunst und relationalem Design. In: *Beseelte Dinge: Design aus Perspektive des Animismus*, J. Dörrenbächer and K. Plüm, eds. Bielefeld, Germany: Transcript-Verlag.
- Zumthor, P. 2006. *Atmospheres: architectural environments –surrounding objects*. Basel: Birkhäuser.

# Good or bad, nice or ugly? – Some exterior colour design by private houseowners in the northern part of Sweden

Per Jutterström

NCS Colour AB, Stockholm, Sweden  
per.jutterstrom@ncscolour.com

## ABSTRACT

Exterior colour design will always be public and accessible for people in the area of the object. It will create feelings and sensations. It can be considered as good or bad colour design. It can be described as nice or ugly. All depending on the context like the surroundings, the light, the season how all these factors will be discerned by the observer.

By tradition private houses in Sweden has been painted mainly in red but also in whitish and yellowish tones. Due to technical limitations, historical background and from a practical point of view, these colour areas were accessible for the private house owners and from an aesthetic aspect, also suitable in the Swedish landscape with lushly green summers, brownish autumns, snowy white winters and pristine yellow-green springs.

As a result of the development in tinting of paint, where the modern tinting technology now can almost produce any colour shade, the range of colours has extended to other areas. New areas of off-whites, pastels and more chromatic colours have become more used by Swedish private houseowners and as a result, the selected exterior colours now are challenging the observer in a different way that we are used to.

What does it take to consider the choice of the exterior colour of a private house such as good or bad, nice or ugly? Are there principles that can be applied to the use of exterior colours that makes it good and nice instead of bad and ugly? How does the private owners relate to the wide range of colours the producers are offering and marketing for exterior purpose?

This paper will present some selected private houseowners choice of colours for their exteriors and put this into the context of earlier studies of traditional colour scales for exteriors and the colours of the Swedish nature. A number of objects will be presented with an analysis, based on both visual assessment and readings, based on the NCS colour system, of the used colours (see Bergström 2008, Swedish Standard Institution 1979).

**Keywords:** *exterior colour design, colour and light, colour and nature*

## **INTRODUCTION**

Exterior colour design can be carried out in different ways but it always has a context. The object itself has its opportunities due to its shape, volume, style, material and origin. But it is also placed in a context where other aspects such as geography, history, the influx of light and its surroundings are adding information to the appearance. Our judgement of the house will be based on all these parameters and we will define it as good or bad, nice or ugly.

Swedish private houses have a wide tradition of certain exterior colours that have been used over the years. In the remote areas the Falu-red, an iron-oxide water-based paint, has been one of the most common façade colours. Falu-red is a colour with some variations in the deep reddish area which can be illustrated the best with NCS S 4550-Y70R. This colour would definitely in figures be the most used façade colour for private houses in northern Sweden over the last two centuries. Apart from the aesthetical reasons, where the Falu-red will be a perfect match with the colours of the Swedish nature during summer as well as for the other seasons, it has a preserve and protective factor in its paint and been available and affordable for centuries.

Other traditional pigment based colour shades have also being widely used. Falu-red has been, together with other traditional pigments, the main palette together with yellowish-brownish-reddish colours. Colours that are low in chromaticness and higher in blackness, resulting in a modest palette that do not interfere with other houses or the nature.

Over the last decades the Swedish exterior colour palette have been widened into other colour areas, mainly due to technical developments, meaning that colours with higher chromaticness are available for in paint products for exterior use.

## **EXPERIMENTS**

In this study some objects were chosen that simply looked a bit “awkward” and did not follow the traditional colour palette. The objects, all private houses without any close neighboring houses, simply did not fit into the traditional colour scheme and not into the main historic tradition. The façade material for all the houses is wood. All the objects are located near by the main road (E4) close to the coast between Timrå and Älandsbro, places within a distance of approximately 40 km and located approximately 400 km north of Stockholm. All the objects are clearly visible for the cars that are passing by.

The objects have been studied in normal daylight conditions. The façade colours have been measured by NCS Colourpin II and then a visual comparison has been made with a NCS colour sample directly on site. In addition to the actual investigation of the inherent colour, some questions were addressed to the owners of the houses: Who chose the exterior colour? What made you to select this particular colour? On what information and background was your decision made? Are you satisfied with the colour? What colour would you select next time your house will be painted?

## **RESULTS AND DISCUSSION**

All selected objects appear too chromatic in all out of its context. It is also clear that the initial aim for the selected colour by the houseowner was intended to be have a more muted, less chromatic appearance than the final result, what the inherent colour delivered and the perceived colour appeared from a distance.

Earlier studies (Fridell Anter 2000, Fridell Anter and Svedmyr 2003) has clearly showed that it is necessary to compensate the amount of blackness and chromaticness in the process of selecting the colour from a smaller sample. By decreasing the chromaticness with 5-10 units and increase the amount of blackness with 10-15 units the perceived colour of the object will coordinate more with the intended colour.

Object	Inherent colour	Intended colour	Perceived colour
Svarvarböle	S 1040-Y40R	≈ S 2030-Y40R	≈ S 0550-Y40R
Bye	S 0515-Y80R	≈ S 1505-Y80R	≈ S 0530-Y80R
Fröland	S 3005-R80B	≈ S 4502-B	≈ S 2020-R80B
Älandsbro	S 1020-R70B	≈ S 2005-R70B	≈ S 0525-R70B

Table 1: Some of the objects with inherent colour compared to the intended colour by the houseowner and the perceived colour from a distance of approx. 100 meters. All notations in NCS.

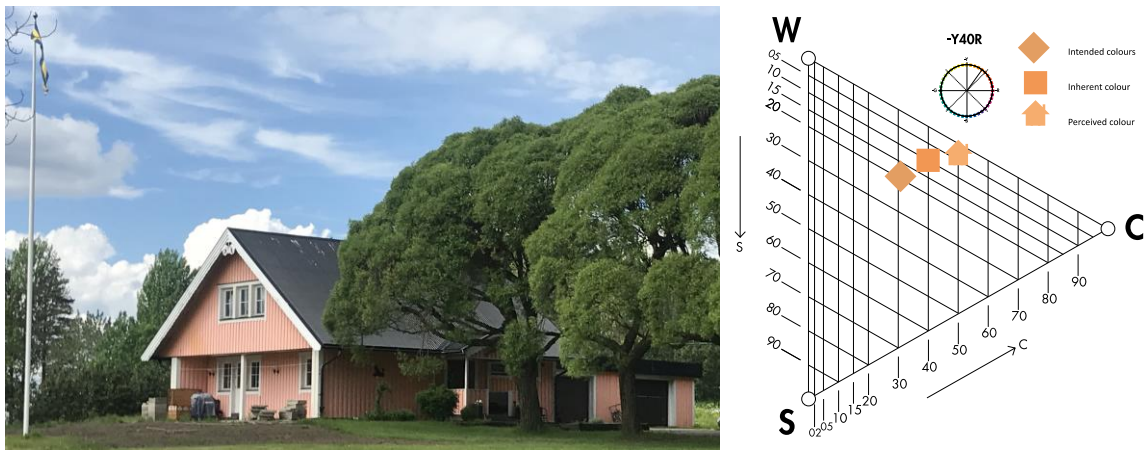

Figure 1: The object in Svarvarböle. Inherent colour NCS S 1040-Y40R, intended colour by the houseowner to be ≈ S 2030-Y40R and the perceived colour from the distance will be ≈ S 0550-Y40R.

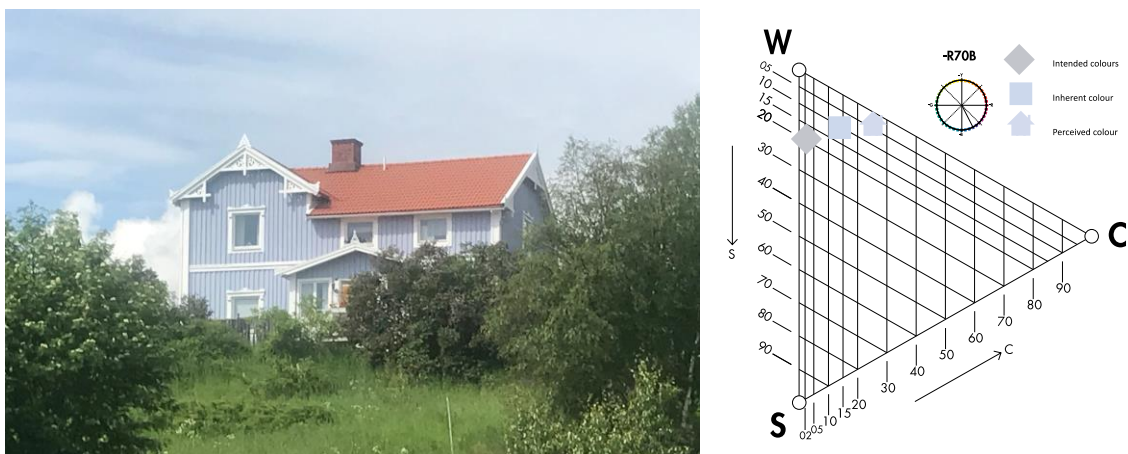

Figure 2: The object in Älandsbro. Inherent colour NCS S 1020-R70B, intended colour by the houseowner to be ≈ S 2005-R70B and the perceived colour from the distance will be ≈ S 0525-R70B.

Blue colours for exteriors are very rare in northern Sweden and only used very rarely for small details, such as doors or window frames, etc., and can not be considered be a part of any traditional colour scheme.

## CONCLUSION

In this study, it is clear that all the different objects and homeowners, have had a similar background and reason for the decision of the façade colours:

- 1) The decision for the selected colour was based on a smaller sample and against a white background.
- 2) The surroundings have not been taken into consideration when the colour was selected including the change of the seasons with clear defined seasons.

There are also reasons to believe that advice and guidance from the point of sales have not been sufficient. With the shift from traditional smaller paint shops, where paint used to be purchased over the counter and managed by more colour experienced staff, to bigger do-it-yourself centers that caters everything in the building process to the lowest cost as possible where usually no advise is given at all.

Future work for this study would be to include more objects and also follow the seasons and the change of the surrounding colours on a more regular basis. It would also be interesting to look more into the situation of the actual purchase of the paint and if there are any changes of know-how and colour advise material.

## ACKNOWLEDGEMENTS

I would like to pay acknowledgment to the private homeowners who contributed to this study.

## REFERENCES

- Bergström, B. 2008. *Colour choices – A practitioner's guide to colour scheming and design*. Stockholm: Formas.
- Fridell Anter, K. 2000. *What colour is the red house? Perceived colour of painted facades*. Stockholm: Royal Institute of Technology, Institution of Architecture, Department of Architectural Forms, doctoral dissertation.
- Fridell Anter, K., and Å. Svedmyr. 2003. *Färgen på huset*. Stockholm: Formas.
- Swedish Standard Institution. 1979. *SS019103 Colour atlas*. Stockholm: SSI. New eds. 1989, 1996, 2004.

# Deriving colour palettes from images of natural landscapes

Jie Yang\*, Stephen Westland, Kaida Xiao

University of Leeds, UK

\* sdjy@leeds.ac.uk

## ABSTRACT

The colours of natural landscapes represent important information about the character of the region in which the landscape is based. The colours extracted from the natural landscapes are considered as the harmonious colour arrangements that could provide a pleasing visual experience to human. In this study, methods to develop colour palettes based on analyses of digital images of natural landscapes are explored. A psychophysical experiment in which participants select five colours that are representative of digital images of landscapes is first described; this generates data that can be used as ground-truth data against which other (more automatic) methods could be evaluated. Automatic methods for generating colour palettes from images using cluster analysis in RGB and CIELAB colour space. A colour-difference metric was used to compare the palettes generated from the designers to automatically generated palettes. There was no statistically significant effect of colour space (RGB v. CIELAB) on the colour differences between visual palettes and those derived using cluster analysis.

**Keywords:** *colour, landscape, natural landscape*

## INTRODUCTION

Natural landscape is one of the most important inspirations for designers. A wide range of colours and colour combinations naturally exist in natural landscapes. There are also abundant colour characteristics of regions, which result from various combinations of rock types, vegetation, local architecture material and soil (Bell 2008). These colours can be used in different design areas including architecture, landscape architecture and urban design, for example, to deliver characteristics to buildings or other infrastructures that enable these structures to blend with their natural surroundings. The particular colour combinations from the natural landscape can be built into a colour palette for designers to inform their design themes. Furthermore, colour palettes are also quite important to image analysis, manipulation and other areas (Ciocca et al. 2019).

Colour palettes that represent images or scenes are generally extracted manually by designers. However, even experienced designers may need to extend substantial effort to build a colour palette



from scratch. Many automatic extraction approaches have been developed to inspire designers to build their colour palettes. Cluster analysis is one of the most common automatic methods (Lin and Hanrahan 2013). A previous study concluded that K-means is fast and efficient to generate different colour regions in images which have closed results to human perceptions (Shmmala and Ashour 2013). Some studies have found that CIELAB provided better performance than RGB space when cluster analysis was used for image segmentation (Mathur and Purohit 2014). In this work, colours obtained by K-means in CIELAB and RGB colour space were compared with the colours that were visually extracted from images by designers using a colour-difference metric.

## EXPERIMENT

A psychophysical experiment was conducted to obtain the colour palettes selected by subjects from natural landscape images. Figure 1 shows all 10 nature landscape images. 30 participants with different design background were recruited to each select 5 key colours for each image which represent the image and could possibly be used in their design work. The digital images were displayed on a computer (HP DreamColor LP2480zx – a 24-inch LCD Backlit monitor) in a darkened room. The images were displayed one at a time and there were 10 digital images in total (each of which represented a natural landscape). The images were displayed on a uniform grey (CIELAB  $L^* = 50$ ) background. For each image, each participant was requested to select five colours and hence obtain a colour palette that represents the image. This was done by the participant clicking on an area of the image using a mouse in a GUI that was written using the MATLAB programming environment. The number of colour in the colour palette was previously investigated by a questionnaire taken by the same design-background participants. 70% of subjects selected five as a reasonable and workable number with regards to colour selection from landscape images. Furthermore, a previous study shows that five is one of the most common values for the size of colour palettes (O'Donovan et al. 2011). In total, 150 colour (5 key colour  $\times$  30 participants) collected for each image from the experiment and these were used as the visual colour palettes in this study.

## ANALYSIS

Figure 2 shows the palettes that were obtained for one of the landscape images as an example. As seen in Figure 2, the colour palettes named DESIGNER are the original colour palettes selected by the 30 subjects. Each row represents one participant, and each column indicates the order of human selection for each image (the left-most colour being the first colour that was selected). Ideally we require a single 5-colour palette that represents the visual selections. However, during the experiment, there were no rules imposed about the order of selection. The order of the colours for each participant were therefore modified. This amounts to changing the order of the colours in each row of the  $30 \times 5$  DESIGNER palette to minimise the colour differences between the colours in each column. This process results in the NEW ORDER palette (see Figure 2 for example). The point about changing the order is to allow the colours in each column to be averaged together and this produces the  $5 \times 1$  palette VISUAL DATA. This  $5 \times 1$  palette is representative of the visual selections and is used as the ground-truth against which the palettes produced by cluster analysis will be compared.

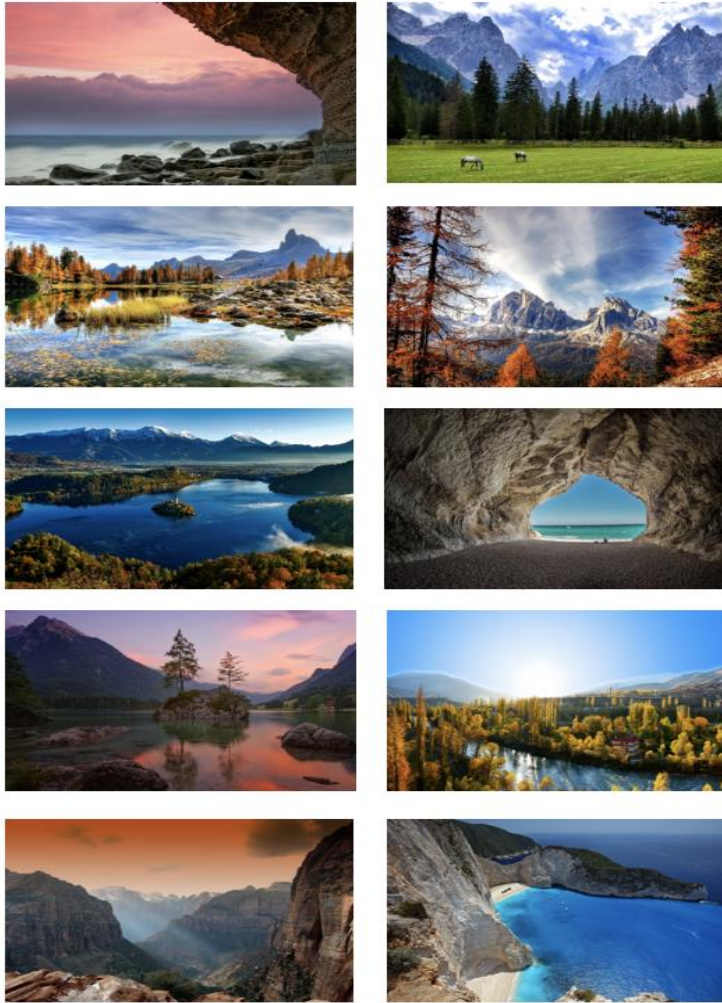

Figure 1: Representation of the 10 natural landscape images used in this experiment.



Figure 2: Example data representation for Image 3 in the experiment. The raw colour palettes obtained visually are labelled as DESIGNER and the visual data shows the average colour palette (VISUAL DATA) produced by the participants. The VISUAL DATA colour palette is compared with the colour palettes produced by cluster analysis using RGB and CIELAB colour spaces.

Subsequently, an automatic method for generating colour palettes from each image was developed using cluster analysis. The cluster analysis, specifically K-means (with  $K = 5$ ), was performed in several different colour spaces including RGB and CIELAB. These are the computed colour palettes as shown in Figure 2.

The colour palettes generated by the automatic clustering method were compared with the colour palettes that were derived from the psychophysical data using a quantitative method that has previously been published (Pan and Westland 2018) that was referred to as the minimum colour difference model. Briefly, for each colour in the first colour palette, the closest colour in the second colour palette is found and this minimum colour difference is recorded. This results in 5 colour differences. The same process is repeated for each of the colour in the second palette, in this case finding the closest colour in the first palette, to produce 5 more colour differences. The colour difference between the palettes is then given by the average of these 10 colour differences.

## RESULTS

Figure 3 and Table 1 show the colour differences (calculated according to the method published by Pan and Westland 2018) between the visual colour palettes and the colour palettes obtained automatically from RGB and CIELAB colour spaces. Overall, the colour differences between visual data and RGB-derived data ( $\Delta E = 12.71$ ) are slightly higher than the visual data compared to the CIELAB-derived data ( $\Delta E = 12.05$ ). However, a two-tailed t-test was used and the difference between the colour differences derived from the two colour spaces was not statistically significant ( $p = 0.82$ ).

However, the fact that the RGB- and CIELAB-derived colour palettes are equally similar to the visual palettes does not indicate that the RGB- and CIELAB-derived colour palettes are the same. To test for this similarity the colour differences were calculated, using the Pan and Westland (2018) method, between the RGB- and CIELAB-derived colour palettes. The mean colour difference was 6.10. This suggests that the RGB- and CIELAB-derived colour palettes are similar but not identical. It may help the reader to note that the colour difference between the RGB- and CIELAB-derived colour palettes for image 3 (as illustrated in Figure 2) was 7.58.

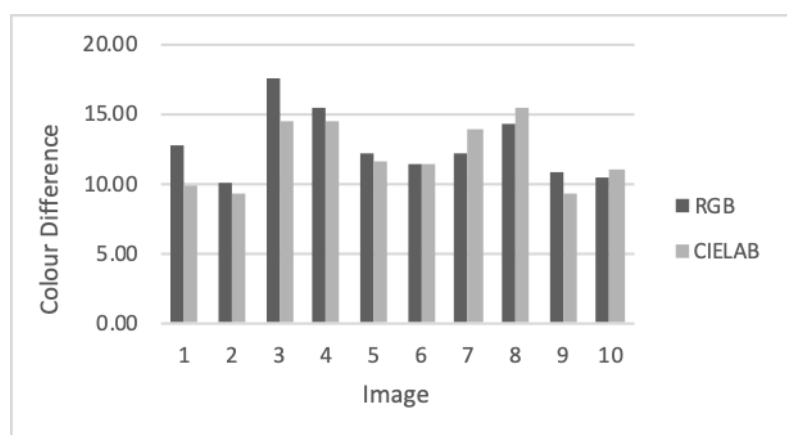

Figure 3: Colour difference between visual data and the computed colour palette from different colour spaces (RGB and CIELAB) for each of the 10 images.

Colour difference		
Image	RGB	CIELAB
1	12.78	9.90
2	10.11	9.34
3	17.59	14.39
4	15.40	14.37
5	12.20	11.51
6	11.37	11.42
7	12.09	13.78
8	14.27	15.49
9	10.79	9.24
10	10.48	11.07
Mean	12.71	12.05
Standard deviation	2.39	2.29
Variance	5.71	5.25
p-value	0.82	

Table 1: The colour difference values between visual data and the computed colour palettes from different colour space (RGB and CIELAB).

## CONCLUSIONS

In this study, cluster analysis using K-means was performed in two different colour spaces (RGB and CIELAB). The choice of different colour space did have some effect (though not necessarily a significant one) on the colours that were extracted. However, there was no significant effect of colour space on the average colour difference between the visual palettes and the palettes derived from cluster analysis. This work suggests that cluster analysis might be a suitable way to extract colour palettes from digital images and that the colour space in which the cluster analysis is performed is relatively unimportant. Although some work has suggested that perceptual colour spaces such as CIELAB should be preferred to spaces such as RGB, other studies have contested this (Chavolla et al. 2018). Some alternative methods, including eye tracking, for automatic palette generation will be explored in future work.

## REFERENCES

- Bell, S. 2013. *Elements of visual design in the landscape*, 2nd ed. London: Routledge.
- Chavolla, E., D. Zaldivar, E. Cuevas, and M. A. Perez. 2018. Color spaces advantages and disadvantages in image color clustering segmentation. In: *Advances in soft computing and machine learning in image processing*, A. E. Hassanien and D. A. Oliva, eds. Cham, Switzerland: Springer, 3-22.
- Ciocca, G., P. Napoletano, and R. Schettini. 2019. Evaluation of automatic image color theme extraction methods. In: *Computational color imaging*, S. Tominaga, R. Schettini, A. Trémeau, and T. Horiuchi, eds. Springer International Publishing, Lecture Notes in Computer Science, 165-179.

- Lin, S., and P. Hanrahan. 2013. Modeling how people extract color themes from images. In: *Proceedings of the SIGCHI Conference on Human Factors in Computing Systems - CHI '13*. Paris: ACM Press, 3101- 3110.
- Mathur, G., and H. Purohit. 2014. Performance analysis of color image segmentation using K-means clustering algorithm in different color spaces. *IOSR Journal of VLSI and Signal Processing* 4 (6): 1-4.
- O'Donovan, P., A. Agarwala, and A. Hertzmann. 2011. Color compatibility from large datasets. In: *ACM SIGGRAPH 2011 Papers on - SIGGRAPH '11*. Vancouver, British Columbia, Canada: ACM Press.
- Pan, Q., and S. Westland. 2018. Comparative evaluation of color differences between color palettes. In: *Color and Imaging Conference 2018* (1): 110-115.
- Shmmala, F. A., and W. Ashour. 2013. Color based image segmentation using different versions of K-means in two spaces. *Global Advanced Research Journal of Engineering, Technology and Innovation* 1 (1): 30-41.

# Impact of concrete in the built landscape

Anahí López<sup>a,b\*</sup>, Alejandro R. Di Sarli<sup>c</sup>

<sup>a</sup> CICIPBA- LEMIT, La Plata, Argentina

<sup>b</sup> UTN-FRLP/LEMaC, La Plata, Argentina

<sup>c</sup> CIDEPINT (CICIPBA-CONICET-UNLP), La Plata, Argentina

\* lopezanahi2002@gmail.com, colores@lemit.gov.ar

## ABSTRACT

Concrete is a material for construction that evolves according to the political, social, economic and technological needs of each region. It integrates a large part of the constructions by their structural or aesthetic functions. Its social impact due to the various functionalities can acquire an artistic or historical character through the monuments, sculptures or urban furniture integrating the built landscape. Concrete is an alternative that allows to materialize thoughts by involving it as a modeling paste, that is, a material without its own shape, that takes the shape of the mold that contains it and whose final appearance is conditioned by the formwork type. This work presents three cases, antagonistic to each other, demonstrating the versatility of mixtures made with cement. The first case is the new Argentine Theater, located in La Plata, built after the destruction of the original building; the second one, the Woman's Bridge by Santiago Calatrava, and, finally, the urbanization plan thought by Francisco Salamone.

**Keywords:** *impact of concrete, buildings, béton brut*

## INTRODUCTION

Concrete is a building material that has been evolving for more than 100 years. Its application has included everything from simple walls, supporting structures and complex shapes to precast with ornamental purposes. As will be seen in this paper, the constructed monuments and sculptures fulfill in general a structural or social function of artistic or historical nature. The properties of concrete were varying according to the used materials. For many years, the humanity has strived to make constructions with relevant beauty. Natural stones were the building materials used since ancient times. With the passage of time, concrete appeared as a new alternative of interest. Not only was its use benefited by the "rough" appearance, but also by the mechanical and structural properties it provided. During the search to obtain new forms the architects found in the concrete appropriate qualities to spread their use. Driven by architects such as Le Corbusier, Gropius and Alvar Aalto, the

applications sought to highlight the use of facades developed at the modernism stage. In addition to the facades design, new forms and huge possibilities of colors and textures were incorporated. These trends diminished the monotony in which concrete worked but did not address issues related to the environment transforming the building, resembling a box. It was in the 1970s when these shortcomings were improved. Finally, the aesthetic conditions demanded materials with qualities such as absolute homogeneity and surfaces very free of defects (bubbles among the least required), which could not always be obtained (Esqueda Huidobro 1996).

Concrete is one of the materials with suitable properties for various applications and it is logical to find it in very important works that last for its quality. However, its deterioration happens because it is exposed to aggressive external agents. Several important works made up of concrete usually acquire monumental value. A monument (from Latin, *monumentum*, “remember”) is any architectural work with a certain artistic, historical or social value. In ancient times, the term was attributed especially to funerary works, and during the Roman Empire, it was the monument dedicated to the emperor and his court, usually being a statue or an obelisk (González Martínez 2008). For many centuries, it was applied to the structure that stood in memory of a relevant personality or event, but nowadays it involves any historical construction whether urban or rural that may or may not acquire heritage value. For many years, humanity has striven to make constructions with relevant beauty. Natural stones were the most used building materials since antiquity, and concrete appeared latter as an interesting alternative because its use provides mechanical and durable properties, but also its “rough” appearance assimilates it to natural stone. With it, structural elements can be manufactured in shape of columns, beams, arches, or other parts made in the place of construction (*in situ*) or in factories (casting concrete).

This work presents three cases, antagonistic to each other, demonstrating the versatility of mixtures made with cement. The first case is the new Argentine Theater, located in La Plata city, Buenos Aires province, built after the destruction of the original theater; the second one, the Woman’s Bridge, by arch. eng. Santiago Calatrava, and, finally, the urbanization plan thought by arch. eng. Francisco Salamone.

## ADVANTAGES AND DISADVANTAGES OF CONCRETE

Concrete is the most commonly used material in construction because of the wide variability of applications. Some of them are its ease to be placed, economical, durable; it can be produced in a variety of forms where it will be building. It can also meet aesthetic properties with color and texture. On the contrary, there are some limitations: it has lower compression strength than tensile strength, it is as fragile as the rocks but it is an artificial rock, it is less ductile than metal. The volume can change according to the environmental humidity and temperature. This change sometimes can produce cracks or fissures, so the concrete could be exposed to aggressive agents (Mindess et al. 2003). All materials are susceptible to degradation. The degradation depends on its nature, and can be mechanical, physical or physicochemical (Mindess et al. 2003, Mehta and Monteiro 1998, Irassar 2001). The identification of the causes that produce degradation allows selecting the appropriate technique to analyze the material and to select the restorative or restorative actions (Traversa and Sota 2008). Another kind of degradation of a physical nature, among others, is when there are wet and dry cycles that produce a continuous color change on the surface and thus modify the appearance in the implemented landscape.

The advantages of concrete are enough for architectural building. At the beginning of 20th century, the wide variety of forms, textures and colors that could be obtained was visible. It was a replacement for natural rocks (Esqueda Huidobro 1996). In his doctoral thesis, Pérez transcribes thoughts of Le Corbusier, who incorporates this material into his works, and agrees with this opinion: "concrete constitutes the building's raw material, transcending the scope of the supporting structure. The material expression of concrete makes it worthy of being shown in its brut state" (Pérez 2006).

In the 1930s, with the appearance of modernism, it began to be used on facades. Then, ornamentations were incorporated in the facades (1950s) that allowed applying the concepts of form, texture and color, in addition to the manufacture of precast. The rationalism and expressiveness were the reasons that guided the structures of the facades in architecture (Esqueda Huidobro 1996). Using concrete is an alternative to materialize thoughts involving concrete as a modeling paste that is matter without its own form and that takes the form of the mold that contains it in addition to the appearance of the material that constitutes the mold. This is the concrete that was properly named *béton brut*, beginning the trend of "brutalism" (Pérez 2006). It was sought to take advantage of the concrete rough appearance and the effect of the mold that contains the material (formwork); also, the expression in reliefs conjugated with the environment and thus impact the landscape. Le Corbusier proposes color as a drastic change in the spatial perception of architecture, and his contribution was very decisive for subsequent generations (Caivano 2005).

For a long time, the designers specified large areas of smooth concrete, free of defects, as something easy to create was believed. On the other hand, practice indicated that obtaining the required quality on large concrete surfaces was almost impossible. For example, in the case of vertical casting, although the surface can be treated in some way to achieve greater homogeneity, it was difficult to achieve a total absence of bubbles resulting from being trapped on the surface. The progress in the study of the materials shows how the characteristics and proportions of the materials improve these aspects (Esqueda Huidobro 1996).

### **THE NEW ARGENTINE THEATER IN LA PLATA: GREY CONCRETE ON THE FACADE**

The old Argentine Theater located in La Plata was one of the first local institutions in the modernization of the city. Two main aspects, called cultured and popular, answer the productions to this period (Di Sarli 2014: 15). The old Argentine Theater of La Plata, supervised by the Italian architect Leopoldo Rocchi, was characterized by the Renaissance style (Minni 2012). On November 19, 1890, the Argentine Theater for the first time raised the curtain (Minni 2012). Unfortunately, the building caught fire on August 18, 1977, and had to be demolished by decision of the military government, the authority in command at that time. In 1979 its reconstruction was awarded by competition to the architects Enrique Bares, Tomás García, Roberto Germani, Inés Rubio, Alberto Sbarra and Carlos Ucar. The professionals started the work in 1980 and finished it after 16 years. The theater construction threw a lot of criticism from the La Plata citizens who cataloged it as cold, sullen and even bleak for the use of reinforced concrete and for its enormous size. This design had a typical aesthetic of ethical brutalism because it highlights norms that, adapted to the urbanization of the city evoking its shape with angles and diagonals, is a mega structure that monumentalizes the technique of reinforced concrete and reflects the state power at the time (Minni 2012). Some of these factors were far from the conception of brutalism, that was that of a new form of the modern movement soaked with socialist ideas that appealed to the honesty of materials, in this case of raw concrete.



Concrete and construction technologies evolved to materialize these works. Other examples where brutalist architecture was used in Latin America and are iconic works: the Mariano Moreno National Library by Clorindo Testa, Francisco Bullrich and Alicia Cazzaniga in Buenos Aires, 1961-1990; the Bank of London and South America by Clorindo Testa and SEPRA, Buenos Aires, 1966; the ECLAC building by Emilio Duhart, Santiago de Chile, 1966; the Bank of Guatemala by Jorge Montes Córdova and Raúl Minondo, Guatemala City, 1966 (see <https://elarcondelahistoria>). In all the cases, the buildings color was gray. In particular, the Argentine Theater has pathologies that appear according to the rain cycles such as efflorescence, a defect that clarifies the surface. The work has an impact on the urban landscape of the area since it is in a space assigned to public buildings that have nothing to do with the aesthetic style.

### **THE WOMAN'S BRIDGE IN BUENOS AIRES CITY**

After the Second World War, many bridges had to be rebuilt in Europe and bridge schools were formed that maintained that they should be simple and cheap (Jodidio 1998). This schools mentioned the need to discover the potential of the bridges and get people to enjoy them (Jodidio 1998: 26-27). Calatrava has provided several explanations, talking about factors: design inspiration, location, length, height, materials, the cost factors, and the impact on the environment. In classes to his students, he said "if we go back to a time when there was no difference between the art of architecture and the art of engineering, as I suggested we do at the beginning of my first talk, then we can consider that it is in ourselves, and especially in the new generation, that a rebirth of art happens. It is not only our heritage but also the mother of heritage that we must translate into action through our capacity to make buildings, reinventing them each time". The consideration of the static properties of a bridge is very important. "The bridge's static equilibrium is probably its most essential part, so that if we think of a bridge like a body, this static condition is analogous to the heart. Of course, the body has other parts; in a bridge you have other properties" (Jodidio 1998: 30-31).

The central part of the whole problem is certainly very much about resolving the problem of how to bring the forces from one shore to another (Jodidio 1998: 81). This modality inspired each one of Calatrava's works, and once again he chose concrete made of white cement. The Woman's Bridge represents the woman as the essence of the bridge, and the beauty of the inclined pylon that represents the man who, by means of the shrouds, holds the woman, both entwined in a magical tango dance. This work is the first that Calatrava made in South America and was inaugurated in 2001. The bridge was built to further enhance the area and facilitate communication and transfer on a ride generated from the Hilton Apart Hotel, the Museum of the Sea and cinemas on the east side of Puerto Madero, on either side of Dock 3 linking Puerto Madero to the city and a complex connection between the old town hall, Plaza de Mayo and the Pink House. The web site of Calatrava talks about the solution to this challenge is the Woman's Bridge (<https://calatrava.com>): a structure that consists of a 102 meter (335 feet) long rotating suspension bridge, set between a pair of fixed approach spans. The central section is suspended by cables from a 39 meter (128 feet) high inclined pylon. The timber-cladded deck is only slightly inclined and provides a barrier-free connection for pedestrians and cyclists. This section of the bridge can rotate 90 degrees to allow free passage of water traffic. The weight of the mechanical tower balances the weight of the pylon, allowing the rotational system to be simplified. Built of reinforced concrete and steel and paved with local timber, the Woman's Bridge is illuminated at night, transforming it into a new symbol for Buenos Aires. In conjunction with other recently built structures in the area, the Woman's Bridge contributes to a new sense of place

for Puerto Madero. The structure combines two contrasting colors: the structure of white reinforced concrete and the passing of wood, both worn during the day. The lighting used during the night is the other phenomenon that modifies the landscape.

### **THE URBANIZATION PLAN THOUGHT BY FRANCISCO SALAMONE IN BUENOS AIRES PROVINCE**

The entrance to the modernity in the interior of Buenos Aires province had its impulse from the public works plan carried out during the Dr. Manuel Fresco governorship (1936-1940). The roads, bridges, canals and airfields construction, together with schools and communal equipment works throughout the province, undoubtedly provided, along with work and economic recovery, a better quality of life for Buenos Aires, discouraging a growing process emigration to Greater Buenos Aires as a result of the economic crack in the thirties.

The Municipal Public Works Bond Act of 1928 was the instrument that enabled the execution of works that allowed municipalities lacking professionals to hire them according to tenders. Thus, Salamone designed and directed municipal headquarters, markets, slaughterhouses, hospitals, cemeteries, plazas and parks in many towns in the province. For more than 25 years, LEMIT began its studies and systematic research on the work carried out during this period (Traversa et al. 2017: 9). “The current non-existence of the Salamone professional archive forces to investigate the pre-existing bibliographic data, discarding some works and adding others, in a process that we cannot affirm that it is concluded” (Traversa et al. 2017: 9, 21). Of Italian nationality, Francisco Salamone was born in Leonforte (Sicily), he attended secondary school at the Otto Krause Technical School in Buenos Aires, where he graduated as a master of works and later, in the Córdoba province, Argentina, he founded with his brother a construction company dedicated to public work. In 1922 he graduated as an engineer, but since he directed architectural works his buildings are identified as “eng. arch. Francisco Salamone”. He received national and international awards. Although the dimension of Salamone’s production can be considered extraordinary, its most notable aspect is the theoretical originality of his projects, the audacity and power of the forms, the use of technologies such as the reinforced concrete, the constructive details design, as well as the furniture and lighting fixtures, all of which clearly states a particular way of understanding and expressing modernity (Traversa et al. 2017: 17-29).

For many years the academic milieu cast a cone of shadow that covered Salamone’s work, however, in recent years veils have begun to be uncovered and open doors being the provincial state who has recognized the historical and heritage value of the Salamone urban legacy, architectural and sculptural work, not forgetting the role played by different organizations in each of the locations where the works were implemented. The introduction of innovative construction technologies such as reinforced and prefabricated concrete allowed the introduction of modernity in small towns and localities located in the Argentine pampas. Provincial Law 12854 declared cultural heritage of the Buenos Aires province to movable and immovable properties whose projects and work execution were carried out by him. Salamone built 73 works, 11 municipal palaces, 15 municipal delegations, 16 slaughterhouses, 6 cemetery portals, and 2 park portals in 33 locations of 15 parties.

The first work by Salamone with Art Deco references is the water tank of Alta Gracia municipal slaughterhouse, in Córdoba province, today converted into an agro technical school. It was followed by a municipal building (1934) in Las Varillas, with decorative elements around a circular courtyard, style repeated throughout his extended work in the province of Buenos Aires (Traversa et al. 2017: 21). One of the peculiarities that highlight it is its working methodology in which it applied criteria for

standardization and systematization of data and components, and the repetition of parts in some cases; in summary, his work focused mainly on municipal buildings, cemeteries portal, squares and slaughterhouses construction. The innovative character of the professional was based on the use of white cement, which was impressive by the decade. Most of his work has harmonies combining colors in the gray scale and, in a few cases, red.

## FINAL CONSIDERATIONS

This paper summarizes the impact that concrete has had in specific works and in a planning of public works. In all cases, the inspiration was, among others, to modify the urban landscape through the aesthetics materialized by concrete. Famous professionals, or not so much, seek to apply the concrete brutality or create mixtures that hide it, even combining it with other construction materials. Concrete can look like a sponge or a stone, it can be of different colors and textures. Its impact is impressive if it is used like *béton brut*, it is invisible if combined with other materials, or aesthetic if used by art.

## REFERENCES

- Caivano, J. L. 2006, Research on color in architecture and environmental design: Brief history, current developments, and possible future. *Color Research and Application* 31 (4), 350-363.
- Di Sarli, N. 2014. Historia del teatro en el período fundacional de La Plata (1890-1930): identidad urbana y proyecto artístico. Access, July 2018. <http://sedici.unlp.edu.ar/handle/10915/36340>.
- González Martínez, P. 2008. Módulo V: Registro de bienes patrimoniales. Apuntes de clase. Curso Avanzado de Especialización en RyC de CyBVP en CD. <https://calatrava.com/projects/puente-de-la-mujer-buenos-aires.html>. Santiago Calatrava -Architects & Engineers. Access on July 2018.
- <https://elarcondelahistoria.com/el-primer-teatro-argentino-de-la-plata-19111890/>
- Esqueda Huidobro, H. 1996. *Concreto arquitectónico*. Mexico: Instituto Mexicano del Cemento y del Concreto.
- Irassar, E. F. 2001. *Durabilidad del hormigón estructural*. Olavarría: Asociación Argentina de Tecnología del Hormigón.
- Jodidio, P. 1998. *Santiago Calatrava*. Cologne: Benedikt Taschen.
- Mehta, P. K., and P. J. M. Monteiro. 1998. *Concreto. Estructura, propiedades y materiales*. Mexico: Instituto Mexicano del Cemento y del Concreto.
- Mindess, S., J. Franis Young, and D. Darwin. 2003. *Concrete*, 2nd ed. Upper Saddle River, USA: Pearson Education.
- Minni, A. 2012. Historia de la arquitectura y el urbanismo. Brutalismo. Access on July 2018. <https://historiadearquitectura.files.wordpress.com/.../brutalismo-y-teatro-argentino.doc>.
- Pérez, P. F. 2006. *Le Corbusier desde el Palacio del Gobernador: un análisis de la arquitectura del Capitolio de Chandigarh*. Barcelona: UPC., PhD dissertation.
- Traversa, L., and J. Sota. 2008. Relevamientos y técnicas de estudios de materiales. Módulo XIV. Curso Avanzado de Especialización en RyC de CyBVP, en CD. CIC-LEMIT.
- Traversa, L. P., V. Rosato, and F. Iloro. 2017. *La obra del ing. arq. Francisco Salamone en la provincia de Buenos Aires (1936-1940)*. La Plata: LEMIT, Anales LEMIT, serie III, año 3, N° 9.

# Urban attractors: color and sustainability

**Rui Barreiros Duarte**

Universidade de Lisboa, Faculdade de Arquitectura, CIAUD, Lisbon, Portugal  
rbdapp@gmail.com

## ABSTRACT

Urban attractors are referential objects that create dynamics in the public space by creating intervention polarities. They are meant for living breaks and various types of activities that can participate in their development. The goal is to reflect on color regarding impacting objects for the enjoyment and experience of places. For this, the importance of color and the design conjugated with vegetal elements is valued. The colors of the flowers and supports the design of the additional elements of cover and the day and night information systems, create visual qualities referenced to color and to sustainability. Thus, the aesthetic, the economic and ecological message are articulated taking advantage of its location, shape and dimension complemented by its color, design, information, colorful elements and flowering plants. The color message and plant elements that are combined with support structures maximize their urgent color communication. As a case study we present the metallic trees at The Museum of The Presidency of the Republic, Portugal.

**Keywords:** *color, sustainability, urban attractors, symbiosis, environment*

## INTRODUCTION

The urban attractors are referential objects poetically destined to living breaks, various types of activities and events. They are active supports of a social and environmental critic, to which we can associate Shakespeare's quote: "All the world's a stage, and all the men and women merely players" (*As you like it*, Act 2, Scene 7).

The artistic interventions in public space through urban attractors appear after the sculptures, with graffiti on the walls with colors and drawings. These are referential objects that can be ephemeral. Visually shocking, they articulate with the urban space attracting attention and being a support to events. They propose the interaction with people, a game, and can recover traditional solutions or conjugate nature with structural elements, textures and patterns.

The color, key-factor of look and emotions, develops in three slopes: the color of supports, of materials and of the lights that place objects in the scene. The colors of flowers and plants are an integrant part of the intervention, constituting an integrated whole in which it can be added graphic messages and complementary elements of great visual, critical and media effect.

## THEORY

When they asked Bernard Tschumi why he had painted red the follies of the park of La Villette, he answered that red was not a color, but the sign used to add more mystery to the project. It was the global strategy used in the rational matrix of the park that allowed a semiotic reading of the different Follies relating them to each other (Tschumi 2012).

Red was used as a strategy for abstract thinking. Here, color is the guiding thread that spells out the unity of the set and it is the means of the articulation, not the goal (Figure 1).



Figure 1: *Charters de Almeida* sculpture, University Alley, Lisbon. Photos by R. Barreiros Duarte, 2019.

In this paper, the intervention strategy involves color as a sign in three strands: basic structure; adaptation to variable elements according to predetermined; or controlled attributes as a process which complement the attractors' design. Thus, whether design is unchanging or progressive, compositional dynamics introduce color through diverse materials. The attractors can be phased in time, they are versatile and can metamorphose themselves.

The creation of the dynamics of the game between teams of intervention builds a pedagogic participation that appeals to creativity. It is a way to deepen the communication with people involving them in the creative process through art, playing with the imagination and color. These themed actions can be mediatized by creating a complementary strategy, calling the attention to environmental, social, urban, energy, political, health, educational, themes. They revitalize attention and promote the way to see and look.

The visual strategy of the urban attractors concerns the way of creating from pre-defined parameters of reference, involving color in a system of signs.

Through analogies, it is promoted to think through images that can be supported in diverse scales of metaphors of the nature, also marine. At heart, there is always a base-structure and variables that metamorphose the objects, constituting an open work.

## METHOD

The participation of different age levels involving creativity, the way of seeing and looking, of building patterns from abstract structures, has always been present in art. It is also a part of the traditional colored fabrics, of the cultural bases throughout history.

By crossing influences from the patterns, conjugating full and empty, one can always build with minimum material and obtain the maximum. It is a principle that enriches every time there is a challenge. By valuing color and design through the color of the supports, the drawing of additional elements of covers and the systems of daytime and nighttime, conjugated with the colors of the flowers or colored arrangements, visual qualities that referred to the color and the sustainability are created (Figure 2).

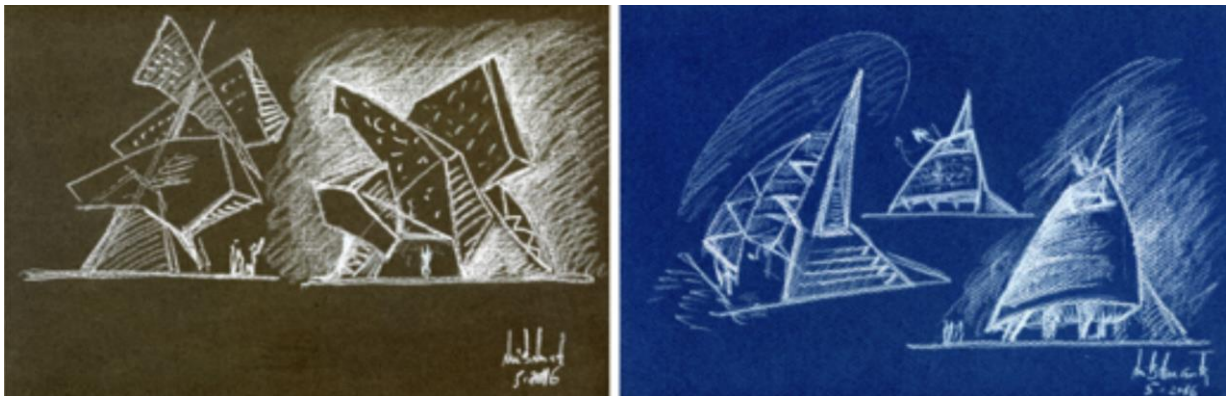

Figure 2: Urban attractors simulations. Drawings by R. Barreiros Duarte, 2016.

Thereby, it is articulated the aesthetic slope, the economical and the ecological message by taking advantage of its location, form and dimension, completed with color, design, information, plants and flowers. These attractors create environments that are welcoming due to their shade, smell and colors, humanizing less friendly areas of the city. Like the analogy, the red follies of Bernard Tschumi in the Park of La Villette in Paris (1987), create polarities in the edges of a reticulated matrix.

One should mention the concept introduced by the birdcage in the London Zoo (1960-1963) of Lord Snowdon, Frank Newby, and Cedric Price, which equates a new relation between the observer and the object of observation. The observer enters the cage and the birds have space to fly and create an integrated intervention, amazing by concept, scale and design.

Besides being an intervention that does not use color, the structure can serve as a reference model to urban attractors that take advantage of dimension through exploration of geometric forms. The supports can be colored, illuminated by lights of different colors and have as a cover both plants and flowers. One can refer to the Orchideorama in the park of Medellin Colombia, of the Plan B Architects and JPRCR Architects. It is introduced a question of scale in the relation among the geometry, the trees and the creation of urban space (ArchDaily 2008).

Through plants, nature relieves the space and creates living areas, fruition and shading, a way of refreshing the environment, being able to add sprinklers that water the plants and humidify the air. This aspect assumes a special relevance in the context of the emerging climate radicalness and of the health problems that arise every time there are heat picks and lack of urban spaces that refresh.

The Singapore Gardens by the Bay (2012) designed by UK architectural firm Grant Associates — a set of 18 metallic super-trees of 50 m height— also creates an exuberant symbiosis in the urban space where the nocturnal image is valued by artificial light. The introduction of solar panels guarantees energy self-reliance and a disclosure of the environmental question (ArchDaily 2012).

The multifunctional urban attractor of significant dimensions of the Plaza de la Encarnación (2009) in Seville by J. Mayer H. Architects, also involves sustainability and the wood color. It is an analogy that can be done in the scope of this reflection, whose goal is to deepen conceptual scopes conjugated with nature in a sustainable, poetical and critical way in the most diverse scales.

**EXPERIENCE:**

**THE METALLIC TREES AT THE MUSEUM OF THE PRESIDENCY OF THE REPUBLIC, PORTUGAL**

For the celebration of the 10 years of the Museum of the Presidency of the Republic of Portugal, 4 “metallic trees” were built that constituted an urban sign and a colored strategy of break and shading before one enters the Museum. These structures also worked as frameworks of events in the patio at the entrance of the Museum (Pinheiro and Duarte 2014, 2015). The use of red and green referring to the colors of the national flag created an expressive and impactful ambiance. The changing colors that illuminated the area at night, gave it a special symbolic environment (Figure 3).



Figure 3: Museum of the Presidency of the Republic, Lisbon. Lighting with the colors of the Portuguese flag. Green: photo by Ana Paula Pinheiro. Red: photo by FG+SG. 2014.

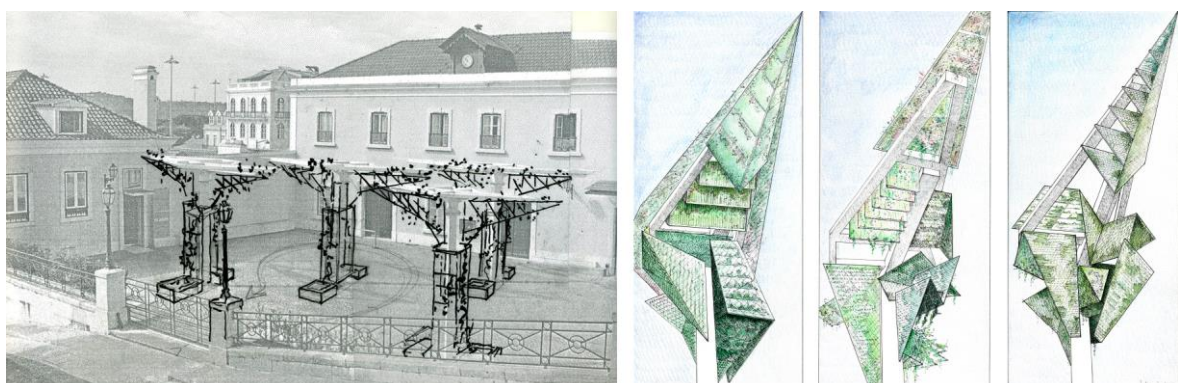

Figure 4: Museum of the Presidency of the Republic, Lisbon. Rehabilitation of the metallic trees: hypothesis and evolution. Drawings by R. Barreiros Duarte, 2017.

In the alteration of this system by lack of maintenance, the coating and the illumination were removed. Only the structures of support remained, having the coatings been replaced by bougainvillea of different colors. Thereby, the paradigm was changed. This started to refer to nature, breaking with the alternatives that conjugate pre-existing fragments. This aspect is a conceptual strategy as variables there were searched. For the new message was designed a support system and metallic cables to route the plants, an articulation with nature that extends the spirit of the palace gardens (Figure 4).

The shading of this set will have a progressive evolution with time, which poetry will be controlled through additional support netting systems. The artificial illumination passes from punctual focuses to value the set. This principle can constitute an analogy that can be extrapolated through diverse types of geometric structure to other areas, allying the ecological and environmental messages, promoting the participation of students and the public in general (Figure 5).



Figure 5: Museum of the Presidency of the Republic, Lisbon. Rehabilitation of the metallic trees: evolution of the bougainvillea growing. Photos by R. Barreiros Duarte, 2019.

## RESULTS AND DISCUSSION

The most important thing regarding the “metallic trees” is the performance that can be obtained through the urban attractors, in artistic actions of urban intervention practically inexistent in this domain. By conceptual and critical extension, the reflection also concerns the strategy that conjugates design and color, recycling fragments of innumerable burden trees in Portugal. It is an investigation that emerges as a counterpoint to the memories of our childhood gardens with their fragrances and colors that mark the seasons.

The cultural entities and traditional celebrations can also involve versatile elements and relevant visual dynamics that are necessary to critically reinterpret the actual condition of the world.

Through the multiple forms and activities, the criticism towards visual pollution and the destruction of nature, the presence of urban attractors interact with the public creating a critical slope in the city life.

The message of color and the vegetable elements that conjugate with minimum structures of support, maximize their urgent environmental message.

The given examples represent diverse types of situations that are close to the scope of the urban attractors’ goal mentioned. Thus, we use analogies to refer to the conceptual field that goes from the *mimesis* to the metaphors with nature, areas that concern recent studies on biomimicry in architecture (Pawlyn 2011).



The interest of the innovative theme is to create symbioses with nature on different scales and to promote the participation of people through art. Developing an original pedagogy, one assumes that with the reduced resources one can create great plastic and environmental effects. Complementarily one can also streamline the interest of companies to sponsor this kind of interventions, passing a colored message of environmental sustainability in which they are also involved.

## CONCLUSIONS

We can systematize the importance of color in the urban attractor, highlighting the sustainability in diverse types of slopes: to create social dynamics in the construction of a collective colored project; to create tridimensional changing structures of urban intervention, that can have a monumental scale; to use the minimum quantity of materials to achieve the effect of a maximum; being themed, removable and versatile structures that take advantage of the chromatic and textural game as a ludic and pedagogic component; being versatile objects, that can be phased and mutable in their evolving and adaptive potential; being themed structures according to the current urgent questions of environmental, energy, social, artistic, pedagogic character.

These attractors, directed to every social layer, create hypothesis of intervention with an aging and social articulation; they encourage creativity and the use of color according to a theme; they interact with artisans to disclose the know-how, namely in the textile domain and in the gardens' art; they encourage an adhocism attitude recovering materials from waste, calling attention to pollution through waste; they can create dynamics of colored games of creative themed participation that can involve social communication; they promote creativity by creating a collective awareness to the role of the transformer of art and to the importance of color; they are a support of the small jobs of cultural character and can constitute the city matrix —as in the analogy to the *folies* of La Villette—, working as a reference point, as a strategy of urban acupuncture and the urban mental map (pathways, points of reference).

## REFERENCES

- ArchDaily. 2008 . Orquideorama / Plan B Architects + JPRCR Architects. <https://www.archdaily.com/832/orquideorama-plan-b-architects-jprcr-architects>. Accessed: August 2019.
- . 2012 . Gardens by the Bay / Grant Associates. <https://www.archdaily.com/254471/gardens-by-the-bay-grant-associates>. Accessed: August 2019.
- Pawlyn, M. 2011. *Biomimicry in architecture*. London: RIBA Publishing.
- Pinheiro, A. P., and R. Duarte. 2014. Ampliação versus sustentabilidade: Museu da Presidência da República. In: *Anais do 4º Seminário Internacional Museografia e Arquitetura de Museus Museologia e Patrimônio*, UFRJ-FAU-PROARQ, Rio de Janeiro – Madrid – Lisboa, 2014.
- . 2015. *Museu da Presidência da República Palácio de Belém*. Lisbon: Museu da Presidência da República.
- Tschumi, B. 2012. *Bernard Tschumi architecture concepts: red is not a color*. New York: Rizzoli.

# Chromatic design in the natural landscape. University student residence in the Campo Escuela FCA-UNC, Córdoba, Argentina

María Marta Mariconde\*, María Inés Girelli, Raúl Darío Suárez

Universidad Nacional de Córdoba, Facultad de Arquitectura, Urbanismo y Diseño,  
Instituto del Color, Córdoba, Argentina

\* mmmconde@gmail.com

## ABSTRACT

Color, as one of the essential components of architectural design, participates in the design process fulfilling different roles according to the specific design intentions of each case. In this way, color acts in new projects, in renovations or in interventions where it assumes the leading role of the engine of change or transformations. In turn, all these participations are given at different architectural and urban scales. In the case of the Faculty of Agricultural Sciences, University Residence, color assumes a vital key part in design due to its role as a transformer of an existing school building in housing.

Within the framework of a collaboration agreement between the Faculty of Architecture, Town Planning and Design (FAUD) and the Faculty of Agricultural Sciences (FCA), both of the National University of Córdoba (UNC), it is entrusted to the Color Institute (FAUD-UNC) the chromatic design of the first student residence of the UNC, belonging to the FCA. The tasks developed included the specific chromatic design by defining the color palette to be used; the advice in making decisions regarding the general arrangement of the common public spaces of the residence and technical assistance of the work. The purpose was to respond to two contextual situations of the project. On the one hand, the architectural typology relationship in a natural landscape, and on the other, the retrofitting of an existing school building that would become housing for students. Given this situation and considering that color should be an element of significance, it was decided to work with a chromatic contrast proposal for both the exterior and the interior of the building.

The design intentions to define the chromatic chart, considering the mentioned conditions, were to work with saturated colors in chromatic contrast over neutral chromatic dominance field. As a result, bluish gray colors were applied to the exterior surfaces of the building and a reddish orange color was used in the main entrance marquee and in smaller outgoing volumes that complete the definition of the façade. In this way it was possible to establish an immediate building-environment contrast. In the interior of the building, following the same project thought, saturated colors, both warm and cold, were applied on smaller surfaces, generating in turn a chromatic contrast over a neutral dominant field. This one conformed by white and gray colors applied in the structure and limits of greater surface. This decision had the sense of generating a lively and cheerful atmosphere, associated with the university student activity.

Considering that color is a material with its own qualities, with the capacity to transform spaces and intervening in perceptual and significant spatial experience, the proposal expresses the protagonism sought for an existing building of large dimensions and whose function has been transformed.

**Keywords:** *architectural color, natural landscape, design*

## **INTRODUCTION**

The present work is framed in a specific collaboration agreement signed between the Faculty of Urbanism and Design Architecture and the Faculty of Agricultural Sciences of the National University of Córdoba, which involves advisory and technical assistance tasks developed by this Institute of Color dependent on the Secretariat of investigation of the FAUD-UNC and as an authorized transfer center (CT) of the UNC, in accordance with Res. HCD 256/16 and the Ordinance of HCS 01/2015.

## **OBJECTIVE**

The aim was carrying out tasks of advice and technical assistance in the chromatic design of the student residence of the Faculty of Agricultural Sciences, located in the School Field of the mentioned academic unit. This involves specific actions of the Color Project and definition of pigments, shades and chromas to be used in sheets with technical specifications; advice on decision-making regarding the general ordering of the common public spaces of the residence and various procedures for the concretion of the proposal.

The purpose of the proposal was to respond to two contextual situations of the project. On the one hand, the architectural typology relationship in a natural landscape, and on the other, the retrofitting of an existing school building that would become housing for students. Given this situation and considering that color should be an element of significance, it was decided to work with a chromatic contrast proposal for both the exterior and the interior of the building.

## **THE INSTITUTE OF COLOR**

The Institute of Color of the Faculty of Architecture Urbanism and Design, UNC, promotes, coordinates, disseminates and conducts research on the color phenomenon and understands that they should not be anchored in the intellectual theoretical field, assumes as fundamental the technological transfer of said studies. It conceives this linkage as a process of recognition of the scientific and technological capabilities available in the university in order to satisfy the existing needs in the productive system through a legal instrument that formalizes the relationship.

All these participations are given at different architectural and urban scales. In the case of the Faculty of Agricultural Sciences, University Residence, color assumes a vital key part in design due to its role as a transformer of an existing school building in housing.

The criterion adopted for the chromatic design was limited to the fact that color should act as a strong instrument to structure and organize the images within a natural context and as an action tool that allows the inhabitant to communicate and identify with the environment they inhabit.

## **DESIGN INTENTIONS**

The design intentions to define the chromatic chart, considering the mentioned conditions, were to work with saturated colors in chromatic contrast over neutral chromatic dominance field. As a result, bluish gray colors were applied to the exterior surfaces of the building and a reddish orange color was used in the main entrance marquee and in smaller outgoing volumes that complete the definition of the façade. In this way it was possible to establish an immediate building-environment contrast.

## **METHODOLOGY**

The details of its enveloping planes were studied, detecting the structure of its parts, both outside and inside, the relationship of full and empty spaces, presence of volumes, columns, beams, large area in gutters and inside, departments, double height, kitchen, stairs, etc. that would make it possible to define and adopt a coherent design criterion in the chromatic arrangements.

In the interior of the building, following the same project thought, saturated colors, both warm and cold, were applied on smaller surfaces, generating in turn a chromatic contrast over a neutral dominant field. This one conformed by white and gray colors applied in the structure and limits of greater surface.

Theoretical positions were adopted that were always present and legitimized the performance of the color on the facades, such as the application of quantitative or surface contrasts and Kircher's law (two tones establish a better relationship when there is a large jump in any of the three variables, preferably in value). In this way the proposal contributed to an adequate "visual comfort" or "good image" or visual balance.

## **CONCLUSION**

Considering that color is a material with its own qualities, with the capacity to transform spaces and intervening in perceptual and significant spatial experience, the proposal expresses the protagonism sought for an existing building of large dimensions and whose function has been transformed.

The proposal of chromatic intervention allowed us to revalue a large typology inserted in a rural environment, isolated and with a strong imprint and made it possible to build the meaning of a strong and efficient environmental image.

This decision had the sense of generating a lively and cheerful atmosphere, associated with the university student activity.

## **ACKNOWLEDGEMENTS**

We thank the agricultural engineer Juan Marcelo Conrero, dean of the Faculty of Agricultural Sciences of the UNC, for convening us for the development of this important work. For entrusting us with such an emblematic work and being able to work with freedom and professionalism respect with the Color Institute and the cooperation between both faculties.

# Luis Barragán among colors and forms: a case-study on project strategies in three of the architect's works

Nathalia Teixeira Gnutzmann\*, Natalia Naoumova, Adriane Borda Almeida da Silva,  
Sandro Martinez Conceição

Federal University of Pelotas (UFPEL), Pelotas, RS, Brazil

\* nathaliagnutzmann@hotmail.com

## ABSTRACT

In this article, we aim to present Luis Barragán's architecture and the influence of form in the choice of color in his works, as well as investigating color as a formal element and analyzing the use of light and shade in the colors used. This way, we searched to analyze the architect's speech to understand concepts of color and form, in order to obtain the basis for analysis of formal schemes and color palettes. In what concerns the contributions expected, we search to find the relation between the adopted form and the choice of colors, also to expand the discussion on Barragán's works. For that, the epistemological option adopted was the method of exploratory case-study. After formal and color analysis from the construction of color palettes used by the architect, results indicate that Barragán's project strategies present analogue complementarity of form and color.

**Keywords:** *Luis Barragán, color, light and shade, form*

## INTRODUCTION

Given that form is not merely visual, but a format of size, color and texture, as defined by Wong (2007), we consider that color, especially under influence of light and shade, may be approached as a formal element of projects.

Architect Luis Barragán's (1980) speech meets this idea, indicating that color and form are equally important elements in his production. In 1980, when he received the Pritzker Prize, he characterized his own production as "autobiographical". Barragán explained that his works were filled with nostalgia of memories of his own life, in a dialogue with popular architecture of the Mexican province and lessons from the people of northern Africa and Morocco, references that are also filled with colors in collective memory.

That put, we aim, with this study, to observe how Barragán's architecture provides didactic frameworks to exemplify possibilities of use of color, light and shade, as a defining element of the formal composition of his works.

## **LUIS BARRAGÁN**

Barragán's architecture, produced between the late 1920s and the mid-1980s, can be understood, according to Júlbez (2013), as having three stages. In the first one, the works mix characteristics of traditional Mexican architecture with typical elements of neocolonialism: rooms distributed in groundfloor, with long corridors; use of ceramic roof tile, elements in wood, full arches, towers and self-supporting masonry.

As for the second stage, it was characterized by the architect's approximation with the European modernist school and the International Style, in the 40s and 50s, when his works started to present the purism and the functionalism of modern architecture: using concrete, steel, aluminum, horizontal forms, pure forms and full coverage. The characteristic of the third stage is the recovery, in his works, of some features of aesthetical and functional treatment from his country. From 1970 on, his works strengthens some characteristics of Mexican culture and habits, as inner courtyards, vibrant colors and textures of local materials. Júlbez (2013), referring to the production of this stage, states that "given the impositions from the radicalism of international architecture, Barragán's work is almost an exception, a contempt" (our translation).

Barragán states that color complements architecture and causes feelings in the spaces and thus, to define it, it is necessary to establish a process of constantly visiting the place of the project, after it is built. This is essential for one to fully understand the phenomenon of interaction between light and matter in the different times and in different times of the year (Schjetnan 1999).

## **COLOR, LIGHT, SHADE AND FORM**

In chromatic theory, color is defined as visual information, caused by physical stimulation, perceived by the eyes and decoded by the brain, that means, as a psychophysical phenomenon. The physical stimulus refers to the impulse caused by the ray of light on the eyes, transmitted to the brain, interpreted as color, according to the wavelength of each incident ray of light. This color and light, in their turn, acquire informative character to decode the visible world (geometry and appearance), including aesthetical performance (associated to cultural constructions). Color is defined by the intensity and the quality of these impulses, thus, it depends on nuances between light and shade. Goethe (1993) considers that "the general feature of colors is that they are half light, half shade".

In subjective terms, color can be characterized from three parameters: hue, lightness and saturation. However, for architecture, what matters is the juxtaposition effect of two or more colors, which brings to the concept of chromatic harmony. According to Itten (1961), when colors that are mutually harmonic are mixed, they produce a neutral grey. That is the case of complimentary colors. Among other harmonic compositions, there are monotonal, analogue and contrasting ones.

Color, according to Wong (2007), is a part of form. For this author, the concept of form comprehends any visible entity that contains every visual element of format (characteristic contour of configuration of the surface of the form), size (physical dimensions of a form), texture (visual and tactile features of the surface, which dictates the degree in which the surfaces of a form reflect or absorb light), including color. This kind of definition is reinforced by Ching (2008), who characterizes forms in format, size and texture. In what concerns dimensional issues of the form, there is the

characterization of the point (dimensionless), the line (unidimensional), the surface (two-dimensional) and the solid (three-dimensional).

According to studies by Efimov (1990), there are two principles of interaction between color and form. In the first one, combination through analogy, composition methods that lead to the union of form and color prevail. In the second one, combination through juxtaposition, contrast or counterposition of colors independently of a formal structure prevails. In architecture, the application of combination principles done through analogy improves the understanding of form and/or its compositive principles, whereas the application of combination principles through counterposition provides freedom for the color, regarding form, its parts, details and volume.

## MATERIALS AND METHODS

The method of this work is case-study, with a didactic exercise that develops the analysis of the color and form conception through images of Luis Barragán's works. Documental research has served as material for developing the investigation, based on photographic images. In order to assure that the study is rigorous, every image was selected from a same photographer, Sebastián Saldívar. They belong to the book *Luis Barragán*, by Reverté and Labanda (2013).

This way, analysis were carried out from the framings and moments of interaction between light and matter that were selected by the authors mentioned above to describe Barragán's architecture. In this work, we studied photographs of three residential buildings, each one representing one of the three periods of the architect's career.

From the houses, we selected photographs of two environments to study the composition adopted for form and color. Colors were identified using Adobe Color CC (Creative Cloud). In what concerns form, analysis were based on the theory of visual (Wong 2007) and primary (Ching 2008) elements of the form. To understand the two kinds of connection between color and form, either by analogy or contrast, the following criteria were assessed: a) dominant hues; b) nuances of these hues, derived from changes in lightness and saturation, with interference of light and shade; and c) the corresponding kind of harmony, identified in the chromatic circle.

## CHARACTERIZATION OF THE BUILDINGS AND ANALYSIS

**Casa González Luna** (Guadalajara, 1928) is organized in two floors, with the flux distributed along a central corridor. In the pergola area, identified in the blueprint with the letter A (Figure 1), one sees a structure of horizontal and vertical rectilinear elements (beams and pillars), defining a volume in space and setting a pace for form and color through contrasts between full and empty. There is the yellow hue, present in the openings and floor, transiting to the vegetation's green. The shade of white becomes evident through the influence of light and shade, and contributes for the perception of rhythm, not only because of the materiality of the pergola, but also because of its shade reflected on the floor. In this image, the natural wear of materials and color contributes to the variation of the dominant palette and to the perception of the analogue relation that belongs to this environment.

Inside the house, in the living room, identified in the blueprint with the letter B, the volume is limited by a vertical plan with arch and three on the wall, being that the external one is configured by a sequence of openings. In the same perspective, one notices an environment that is composed of a

monochromatic combination, with a hue that transits between yellow and orange-yellow, varying luminosity according to the space configuration, the almost-white areas and the high ceiling.

The unity between inside and outside lays in the pace that is set through the repetition of elements that enframe the openings for the light, varying only between vertical (windows) or horizontal (pergola) direction.

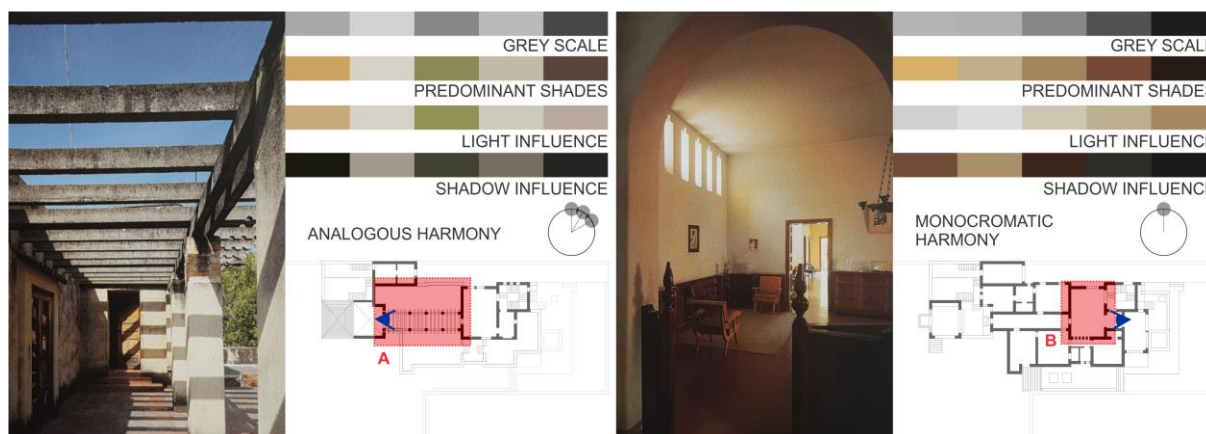

Figure 1: Color synthesis – pergola area (left) and living room (right). Source: scheme created by the authors, based on Reverté and Labanda (2013).

**Luis Barragán's Home and Studio** (Mexico, DF, 1947) is organized in three floors; the architect's residence and studio gains a rectilinear orthogonal feature ([www.casaluisbarragan.org](http://www.casaluisbarragan.org)). Comparing both environments in the photographs (Figure 2), one observes that he continues with strategies of effects of light and shade, with variations between horizontal (zenith illumination for the studio) and vertical (the window frame that enframes the landscape) plans. As for colors, it highlights form (composition through analogy), seeming as a saturated color (yellow).



Figure 2: Color synthesis – studio (left) and living room (right). Source: scheme created by the authors, based on Reverté and Labanda (2013).

In the image of the studio, identified in the blueprint with the letter C, one observes the use of the yellow hue in the coverage plan, that reflects over the plan of white walls, creating monochromatic harmony through the effects of light and shade. In the image of the living room, identified in the blueprint with the letter D, one notices that the hue of the natural wooden floor of



the plan mirrors in the white walls, maintaining a chromatic unity of the whole work in yellow hue. This effect is evident through the vertical glass plan, which highlights the green color that comes from the vegetation.

In the two environments analyzed, the white hue has a function of creating a base, a background, to the detriment of others. It is also observed that the proportion of use of saturated yellow is minimum. Monochromatic harmony, that unifies the composition, shows up as a remarkable strategy to create an intimate atmosphere.

**Casa Gilardi** (Mexico, DF, 1976) is a compositive organization that develops around a preexisting tree, in a narrow lot. The building fills the whole width of the lot and is divided in two blocks that connect through a corridor, limiting the yard that hosts the jacaranda tree that conditions the architectural concept.

The space of the corridor that gives access to the pool, identified in the blueprint in Figure 3 with the letter E, shows the maintenance of a repertoire that was already announced in his first stage of projecting, but takes a pace with stripes, marked by the entrance of light over the vertical plan. It also keeps a lighting game, with predominance of warm colors, with variations of the yellow hue. The architect adds a playful feature to the environment, composing this yellow with blue and red, both saturated (primary colors and an isometry: triadic). However, the walls received the white color. Yellow is in the color of the glasses. The effects of light and shade rule the yellowish nuances, framing the background environment. Barragán provokes this rupture of the building's orthogonality by comprehending the dynamic drawing of the light and the physical phenomena of interaction with matter and respective shades.

In the image of the area with the covered pool (letter F), the architect's control of proportions between color areas is highlighted. So, regarding the plans that compose the volume, red shows as minimum area in the pillar, white as the base color of the walls and blue as that vertical plan in the background of the pool. The effects of light and shade come from the zenith luminous focus, oriented to the water, and the dark tones of the groundfloor. In this perspective, we identified the combination and the triadic harmony, in addition to the presence of light blue and pink, resulting from the reflection and illumination of the materials.

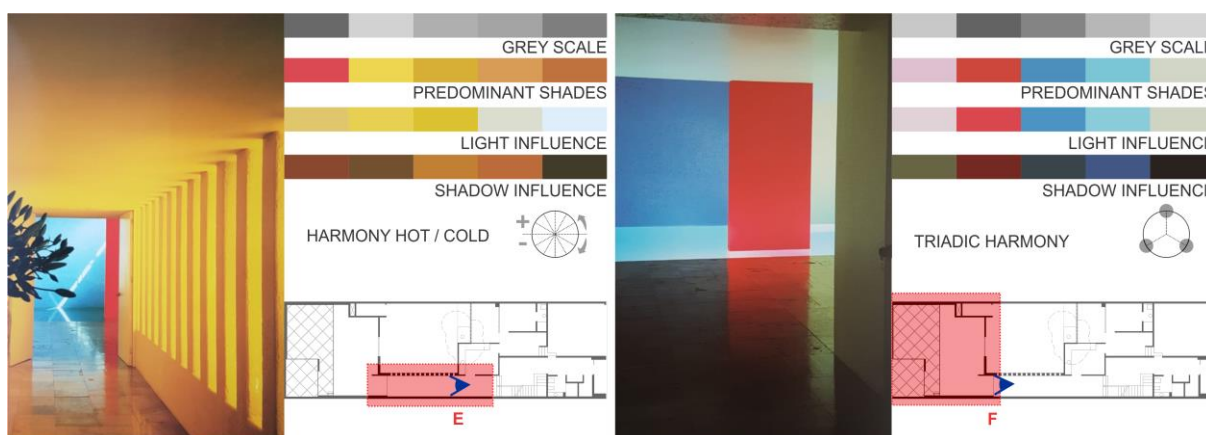

Figure 3: Color synthesis – corridor for access to the pool (left) and covered pool (right). Source: scheme created by the authors, based on Reverté and Labanda (2013).

## CONCLUSION

Results of the study-case analysis, together with literature review and the architect's speech, show a trajectory of his production in architecture that led to a precise control of the form, without discerning from Barragán's concept of color and both formal and chromatic evolution throughout his career. In opposition to the internationalization ideals that the modern movement indicated, with use of great glass plans and hegemony of white, he searched references in regional architecture and painting, valorizing intimacy and serenity, through an effective incorporation of color in the form, in his composition. The formal aspects adopted by Barragán and shown in this work show the use of primary elements of lines and plans, as well as colors (yellow, blue and red).

To dwell on each photograph of the architect's work constitutes a strategy to follow a formative process of architecture in volumetric compositions, materialized through mastering visual elements of format, size, color and texture. The application of rectilinear elements defining plans or openings is also part of his formal vocabulary.

We noticed that strategies of application of color are subject to the conditions of luminosity of the place, which were widely explored by the architect. We also indicate the use of Efimov's principle of combination through analogy, in which there is a union of color and form. We conclude that the conception of color and form, in Luis Barragán's production in architecture, is inseparable, at least in the three houses analyzed. Further research may cover more works, aiming to expand the study of the architect's project strategies regarding form and color.

## REFERENCES

- Barragán, L. 1980. Acceptance speech. In: *The Pritzker Architecture Prize*. [https://www.pritzkerprize.com/sites/default/files/inline-files/1980\\_Acceptance\\_Speech.pdf](https://www.pritzkerprize.com/sites/default/files/inline-files/1980_Acceptance_Speech.pdf). Accessed: July 19, 2018.
- Ching, F. D. K. 2008. *Forma, espaço e ordem*. Sao Paulo: Editora Martins Fontes.
- Efimov, A. 1990. [*The city polychromy*]. Moscow: Stroizdat.
- Goethe, J. W. 1993. *Doutrina das cores*. Sao Paulo: Nova Alexandria.
- Itten, J. 1961. *The art of color: the subjective experience and objective rationale of color*. New York: Reinhold Publishing.
- Júlbez, J. M. B. 2013. Barragán cabalga rumbo a la eternidad. In: *Luis Barragán*, R. Reverté and J. Labanda, eds. Mexico: Editorial RM, 9-41.
- Reverté, R., and J. Labanda, eds. 2013. *Luis Barragán*. Mexico: Editorial RM.
- Schjetnan, M. 1999. *En el mundo de Luis Barragán*. Mexico: Editora Artes de México.
- Wong, W. 2007. *Princípios de forma e desenho*. Sao Paulo: Martins Fontes.

# The color of roofs and sustainability

**Ana Paula Pinheiro**

Universidade de Lisboa, Faculdade de Arquitectura, CIAUD, Lisbon, Portugal  
apprbd@gmail.com

## ABSTRACT

The aim of the paper is to ally the color of roofs to its technical and energy component. Roofs are determinants in the urban image, especially in cities of multilevel appreciation, and have an essential role in sustainability. The ceramic roofing is still one of the most efficient solutions in the passive sustainability for coverings, with great durability and high resistance. White roofs have been used over the centuries in Mediterranean countries. They are suitable for hot climates saving energy in cooling systems. Another kind of colored roofs are the living roofs, covered with vegetation. They are called green roofs but in fact they can have several colors, depending on the vegetation chosen for their coating. All kinds of roofs can be coated with modules and photovoltaic elements allying technology with design. As a case study we will present the rehabilitation of the Cathedral of *Portalegre*, cloister and annex spaces, in Portugal.

**Keywords:** *tile roof, white roof, green roof, glass roof, sustainability*

## INTRODUCTION

Whatever the color or material of the project, its design should reconcile the idea with aesthetics and technical requirements.

Ceramic tile (brick color) was one of the first man-made building materials. In addition to the vibration of the possible shades, one can take advantage of the tinting and paint to obtain a colored pattern or use a glazed ceramic with plastically controlled color variations such as the *Casa Batlló* in Barcelona, Spain (Figure 1).

Roofs painted in white absorb less heat than common roofs due to sunlight reflection. This feature allows reducing the heat transferred to the interior of the building, thus improving the comfort of the occupants. Its white color can also be obtained by painting with reflective paint and therefore with high solar reflectivity and high infrared emission. They are called cold coverings.

Green roofs are living roofs covered with vegetation and they can accentuate the season of the year or the respective change, allowing a metamorphosis of their image throughout the time (Figure 2).

Moreover the aesthetic and aromatic qualities of the flowering areas, green roofs also allow to reduce the presence of the construction. It is important to use sustainable native plants that are resistant to drought and do not require excessive watering (Pinheiro 2018).



Figure 1: *Casa Batlló*, A. Gaudí, Barcelona, Spain. Photo by A. P. Pinheiro, 2018.



Figure 2: *Calouste Gulbenkian Foundation*, Lisbon, Portugal. Photos by A. P. Pinheiro, 2016 and 2018.

The glass roofs can have various colors, allowing to combining several levels of transparency with electric power generation and water sealing.

Several countries have created regulations and legislations to ensure the construction of green roofs and/or white roofs primarily for ecological and heat-absorbing reasons.

## THEORY

The colors of roofing ceramic tiles have different shades, and the same happens to the glazed tiles. We can find in Islamic tradition, in richer buildings, coverings with green glazed tiles. Here we introduce a symbolic factor that can be associated with sustainability.

This field of investigation is very important due to the use of dyes and paints which have characteristics that can be highly polluting (Torgal and Jalali 2010). This aspect overlaps as an environmental concern to the aesthetic performance. However to associate both investigations is determinant in interventions.



Figure 3: *Santorini, Greece*. Photo by Maria Rebelo, 2016.

In white roofs, the paint traditionally used in the Mediterranean countries is due to air or dolomitic lime (Figure 3). It is thought that the lime has been discovered at the beginning of the Stone Age, Paleolithic period, having been used as a construction material in the Pyramids of Egypt and the Great Wall of China (Coelho, Torgal and Jalali 2009).

Nowadays, paints with different characteristics are used —their elastic qualities are important to avoid earlier degradation. Whatever is the used material in the coating of the white roofs, it is fundamental to have in consideration its maintenance in order to keep the purity of the color.

As it has been referred, the color white, besides its aesthetic quality, confers thermal insulation to the coverings, due to sunlight reflecting.

Nanotechnology can introduce qualities that avoid dirt and cracking, repelling dust. In a certain way, it is also the role of ceramic elements, as it happens in the Sydney Opera House.

To achieve the “NZEB Nearly zero-energy building, which applies to new public buildings from 2018 and all new buildings from 2020” (Pinheiro 2013) it is fundamental to use renewable energies in buildings. However, the dark color of the photovoltaic cells has a negative visual impact in the image of the traditional tiled roofs of brick color. This problem aggravates when thinking of architectural heritage rehabilitation as it creates a great contrast with the covering colors.



Figure 4: Solar tile *SOLESIA* in ceramic roof tiles called *Lusa* tiles. In: *Umbelino Monteiro Catalogue*, 2016.

In Portugal, only the company *Umbelino Monteiro* has a solution to incorporate photovoltaic energy in the tiles. This solar tile called *SOLESIA*, developed in 2009, can only be installed in a roof with *Lusa* tiles, replacing 9 ceramic tiles (Figure 4). This kind of solution is named “tile” but in reality it looks like a photovoltaic panel. The advantage is to be integrated into the roof instead of becoming prominent as the common photovoltaic panels that interfere with the set image.

### CASE STUDY: THE CATHEDRAL OF *PORTALEGRE*, CLOISTER AND ANNEX SPACES, IN PORTUGAL

The covering of the central nave and the north chapels of the Cathedral of *Portalegre* are coated with ceramic roof tiles called Roman tiles, applied in 1940 by the General Directorate of National Monuments (Duarte and Pinheiro 2016) (Figure 5).

Besides that, the General Directorate of the Cultural Heritage, DGPC, supervisor entity of the heritage interventions, demands the replacement of the existing Roman tile, by straw tile (*canudo*) to be placed in the rehabilitation of the Cathedral.

Due to this constraint of the DGPC, the following principles of intervention were chosen:

- Rehabilitation of heritage buildings' roofs with straw tile (*canudo*).
- New volumes with green roofs and green facades.
- The roof of the building not classified as cultural heritage with solar tile *SOLESIA*.



Figure 5: Cathedral of *Portalegre*: existing roof in ceramic roof tiles called Roman tiles. Photos by RBD.APP, 2016.

As referred, in Portugal there are no solutions that incorporate renewable energies in roofs of straw tile (*canudo*). So, the option was to place a photovoltaic system in the rehabilitation of the building that will serve as an entrance to the Museum of the Cathedral. This building is not classified as cultural heritage and has had a lot of functions, from fire station to bank agency.

Thereby, it was proposed that the straw tile (*canudo*) coating the roof turned to the side of the Square of the Cathedral; *SOLESIA* tiles coating the roof turned south and that is not seen by the entrance (Figure 6).



Figure 6:  
South view: Rehabilitation of  
the Cathedral of *Portalegre*.  
RBD.APP, 2017.

## CONCLUSION

It can be verified the existence of an identity between color and roof features, with which it is intended to achieve sustainable characteristics.

These factors occur in a cultural order, but they can be optimized by technical knowledge articulated with the market production.

There is also a big path to be done in this domain in terms of tiled roofs so that they can incorporate photovoltaic elements.

## REFERENCES

- Coelho, A. Z., F. Torgal, and S. Jalali. 2009. *A cal na construção*. Guimarães: Universidade do Minho, TecMinho. Online: <http://repositorium.sdum.uminho.pt/handle/1822/28972>.
- Duarte, R., and A. P. Pinheiro. 2016. *Relatório prévio – Reabilitação da Sé Catedral de Portalegre, claustros e espaços anexos*. Architectural report for the General Directorate of Cultural Heritage (DGPC), Portugal.
- Pinheiro, A. P. 2013. Architectural rehabilitation and NZEB: The expansion of the Library of FDUL. In: *Green design, materials and manufacturing processes*, H. Bártolo et al., eds. London: Taylor & Francis.
- . 2018. The green in architectural rehabilitation. In: *Proceedings of the International Colour Association (AIC) Conference 2018*, Lisbon, 25-29 September 2018, M. Gamito and M. J. Durão, eds. Newtown, NSW: International Colour Association, 165-169.
- Torgal, F., and S. Jalali. 2010. *A sustentabilidade dos materiais de construção*. Vila Verde: Universidade do Minho, TecMinho. Online: <http://repositorium.sdum.uminho.pt/handle/1822/28852>.

# Urban Landscape





# The relevance of light and colour in current architecture: possibilities and challenges

**Raúl Darío Suárez\***, Carlos Augusto Zoppi

Universidad Nacional de Córdoba, Facultad de Arquitectura, Urbanismo y Diseño,  
Instituto del Color, Córdoba, Argentina

\* radasuarez@yahoo.com.ar

## ABSTRACT

In the contemporary world, important transformations in the materiality of architecture are proven, where light and colour, as relevant components of urban architectural design, are generators of new expressions that enable current technologies. Regarding the light and chromatic design, there have been changes facilitated by technological evolution and accompanied by the exchange of experiences between different disciplines that have enriched the debate on the role of lighting and colour. By modifying the spectral characteristics of the light source emission, the result will be different with regard to the perceived colour, both in perceptual and emotional aspects. For that purpose, it is necessary to distinguish between pigment colour, light colour and colour of light. In this context, in order to interpret the possibilities and challenges of materiality in current architecture, which are centred in the relationship between light and colour, they are verified in interventions, such as interior spaces, buildings and urban environments of the city of Córdoba, Argentina.

**Keywords:** *light, colour, architecture, materiality*

## INTRODUCTION

We live in a visual age in which the image of architecture is part of its function. [...] The vertiginous technological advances of recent years, together with the demands of an eager society for sensations, have allowed the design of buildings and interiors of an interdisciplinary nature, in which art, architecture and technology are intertwined and merged.

(Torelló 2015: 173)

In the contemporary world, important transformations in the materiality of architecture are proven, where light and colour, as relevant components of urban architectural design, are generators of new expressions that enable current technologies. They also have the capacity to inform, suggest, rank, develop synesthetic associations and create atmospheres that transcend materiality towards new creative and perceptual dimensions.

Therefore, in today's architecture, the consideration of the variables of colour and light becomes an opportunity to explore possibilities and take on new challenges. The relevance that light and colour have had over time in the configuration of spaces and their expression is known. Light reveals colour and shapes, placing us temporally and spatially, it highlights qualities of materials and stimulates our behaviours. Likewise, these variables have the capacity to influence the tone of the environment, intervening in the perceptual and experiential experience of the architectural and urban spaces.

In recent decades there have been significant changes in electric artificial lighting, due to technological advances in relation to their spectral characteristics among others, as light has the attribute of modifying the perception of spaces, people and objects.

By modifying the spectral characteristics of the light source emission, the result will be different with regard to the perceived colour, both in perceptual and emotional aspects. For that purpose, it is necessary to distinguish between pigment colour, light colour and colour of light, gazing at the tone, the chromatic reproduction index (CRI) and the colour of the light.

In this context, interventions, such as interior spaces, buildings and urban environments of the city of Córdoba, Argentina are verified. According to Schindler and Cler (2017: 51) "the architectural practice has recognized new and contradictory possibilities for colour". Consequently, investigating and reflecting in the variables of colour and light, encourage the reading of architectural and urban facts to interpret the answers to the possibilities and challenges of materiality in current architecture.

## **LIGHT, COLOUR AND MATERIALITY IN CURRENT ARCHITECTURE**

The colour and light as expressive components of urban architectural language have progressively gained importance by the end of the twentieth century. Nowadays, the projects become sources of light and colour that modify expression and spatial experience (Bahamón and Álvarez 2010). For this reason, different spatial configurations reveal the use of traditional materiality, and also the expression that technology and new materials enable as responses to the search for novelty and innovation. This is evidenced by international works such as the following examples (see Figure 1).

### ***Atrium, University of Jussieu, Périphériques Architects, Paris, France, 2006***

It is located in a regular university campus, is uniform in materials and colours. In this building, the designers appealed to the clear differentiation of the environment using as a project strategy the use of colour in its interiors. The facades are constituted by a double skin, an exterior of perforated metal panels and another interior, of glass maintaining the design and materiality of the neighbouring buildings. The interior spaces have been finished with bright pigment colours that identify the different uses, and this is where the use of colour in relation to light becomes significant and enables the perception of different day and night images. The night image is where the colours are transformed into the distinctive feature of this building with regard to the environment, while artificial light enhances the colours, by means of reflections and transmissions through the two layers of the facade. There is an interaction between colour and day and night light working with a traditional materiality.

### ***Dutch Institute of Audio-visual Media, Neutelings Riedijk Architets, Hilversum, Netherlands, 2006***

It is located in the city of Media, near Amsterdam, the building has been known as a large television screen and a large box where treasures the memory of the country. The facade consists of a glass skin, in which images in relief and colour that represent the variety of archives of the institute have

been applied. This is when the coloured light becomes the protagonist through the filters of the facades creating vibrant and polychromatic interior atmospheres; and also impacting the urban landscape. The facade is perceived as composed of a mixture of colours that gives it dynamism, both day and night.

**One Central Park, Atelier Jean Nouvel, Sydney, Australia, 2014**

A set of buildings in an urban renewal area in Sydney proposes not only gigantic vertical gardens but also new uses for the urban area. In addition to these innovations, designers play with the changing lights of Sydney through a cantilever structure composed of a set of motorized mirrors that reflects the sun's rays towards the gardens of Central Park. At night, this mirrored element is transformed into an LED light art installation created by the artist Yann Kersalé. Consequently, important transformations in the materiality of architecture are proven where light and colour, as relevant components of urban architectural design, are generators of new expressions and enable current technologies.

**Uniq Tower (Neumann + Partners / Andreas Schulz, Licht Kunst Licht study, Vienna, Austria, 2006**

It is an emblem of the city of Vienna. It initiated a new concept of lighting of corporate buildings, which use their facades to create attraction and differentiate themselves from their surroundings through a curtain wall incorporating a medium matrix. Playing with the materiality, the programmed play of lights and the movement this building dominates the perception of the urban environment which is an aspect cause of discrepancies among the population.

**Agbar Tower, Jean Nouvel and b720, Barcelona, Spain, 2005**

It is a controversial and attractive tower that became an icon of a contemporary Barcelona, incorporating the concept of "architecture of light". It is located in an area of urban renewal that marks the beginning of the technological district of Barcelona. Its plants, without edges, are covered with rectangular windows and by 56,619 sheets of translucent glass. The particularity of the building is in the light and the play of reflections through those windows. It is a sign of identity of the works of Jean Nouvel. The chromatic role of the facade, with opacities and transparencies, is solved with two skins, one of them is composed of glass slats that allow the building to vary in its perception during the day and the seasons. The facade has outdoor temperature sensors that regulate the opening and closing of the glass lattices that conform the skin of the building.

The colour, in addition to the shape, is the hallmark of this building, especially at night when the facade is transformed into an object of light and colour. It has more than 4,500 luminous devices using LED technology which allow the generation of dynamic images on its façade. Both in its day and night image, it has become part of the urban landscape of the city. The system allows to project 16 million colours, thanks to a sophisticated hardware and software system, in addition to the ability to create colour transitions also independent, without appreciating delays and creating a shocking effect. The usual colours are blue at the top and red at the bottom. With this work, the architect wanted to pay homage with a geyser in the light of Montserrat and Gaudi with the red earth.



Figure 1: International case studies.

In the works described, new expressive modes of colour are evident. In addition, these interventions propose a different way of suggesting, informing, and stimulating the sensations and perceptions of the users in the spatial experience (Figure 1).

## WORKING METHODOLOGY

The study of the relevance of chromatic expression and lighting in the architecture of Córdoba city, led to investigate and reflect in the variables of light and colour to verify the possibilities and challenges. Studying the interaction between colour and light implies the consideration of the spatial physical context in addition to the temporal history in which these phenomena occur. For the development of this work the following instances were carried out:

- The identification of *case studies* was carried out by selecting relevant examples located in areas with a recognized identity: Historical Centre (foundational area), Plaza España area (Nueva Córdoba neighbourhood), Güemes neighbourhood and Civic Centre. Besides, other examples were considered as institutional and corporate buildings, among others.
- In each particular case, specific analyses were performed: *colour variables* (characteristics of colour, materiality, historicity, day-time and night-time situation; *light variables* (natural light and artificial light, light tone and chromatic reproduction in relation to materiality).
- From the relationship between these variables, *the design criteria* used were interpreted.
- Finally, the *possibilities and challenges* of materiality in the current architecture were defined.

## LIGHT, COLOUR AND MATERIALITY IN CÓRDOBA CITY

In the context of the Córdoba city, there are architectural works and urban interventions where it is possible to interpret the use of colour and light as an expressive design resource. The reading and interpretation of the chromatic and light design in the different case studies can be synthesized in (Figure 2).

### **Historic centre**

The historic centre is configured by architectural typologies from different eras, including particularly the colonial and 19th-century ones; religious and institutional typologies stand out, as it is the foundational area. In this sector, heritage buildings such as the Cathedral, the Cabildo, the churches and the Liberator Theatre, among others, have been valued. In these buildings, it is emphasized the work with traditional materiality using different intervention criteria. In the last decade, for the purpose of generating new appearances and different chromatic expressions, dynamic lighting using RGB LED technology was used. The result was a contrast in the colour perceived between day and night, the modification of the night landscape is notorious. In recent years, a criterion of respect for the chromatic characteristics prevails, highlighting the original language of the buildings through static illuminations. For that purpose, traditional lighting technologies have been used, except for the recently intervened Liberator theatre, where LED technology of warm and neutral tones has been used, and also chromatic reproduction according to the characteristics of the building.

### **Plaza España area (Nueva Córdoba neighbourhood)**

The neighbourhood of Nueva Córdoba, is an urban expansion of the early twentieth century with urban and architectural features of the nineteenth century. Currently its urban image shows a great renovation in its architecture, where the typology of housing predominates in height. A series of

paradigmatic buildings, containers of artistic and cultural activities, some of them of heritage value, is concentrated in Plaza España area.

In the intervention and revaluation proposals different criteria are detected: the Ferreyra Palace with subtle contemporary interventions on the outside; the Dionisi Palace without interventions on the original architecture; the Emilio Caraffa Museum where on heritage buildings interventions have been made with new materials and of great magnitude and urban impact. It can be also mentioned the new Córdoba Cultural Centre with its Bicentennial Lighthouse. Valuation actions have been carried out in this sector through ornamental lighting, where the use of LED technologies prevails with controls that produce dynamism on the facades, or changes in colour light that modify the original architectural values.

### ***Güemes neighbourhood***

The traditional Güemes neighbourhood, was historically characterized as a working-class district. During the last four decades, a series of urban interventions were carried out where the role of colour and new activities transformed the image and character of the sector. The urban colour design project of the 90s was a vital element in the history of the area in Belgrano and surrounding streets.

The particularity of this case lies in successive interventions of different scales, corresponding to different processes and ideas; among them, urban chromatic design and the recovery of modest architectural heritage. In recent years, urbanity generated in interior spaces and yards or in the middle of the block create atmospheres based on materiality, light and colour.

At the urban landscape level, in the recent action on Belgrano street (structuring axis of the sector), a new urban lighting has been incorporated that does not contribute to defining the night image. For this new lighting that uses LED technology, no attention has been paid to aspects related to the distinctive colour of the neighbourhood; not only the light colour (6000 K) but also the IRC, they do not contribute to reinforce that image linked to the colour.

### ***Civic centre***

It is an urban intervention of the last decade on railway lands, in order to concentrate the main provincial institutional buildings. In the Government House building, popularly known as *El panal* (honeycomb), as well as the new bridges over the Suquía river, the criteria for ornamental lighting are similar to those of Plaza España. In this way, that lightning criteria are expressed with greater dynamism, colour change and unable to detect a clear design criteria. This is evidenced in the night image, whose varied chromatic expression is defined by a changing polychromatic range and configures a low readability facade in the Government House. In the case of the bridges, the dynamism and the change of rhythmic and playful colour do not relate to the context and the institutional character of the area.

### ***Casa Naranja (“Orange House”)***

The new corporate building of Tarjeta Naranja (local credit card company) is located in an area of urban renewal on the Suquía river waterfront. It is one of the recognizable landmarks in the urban landscape next to Capitalinas towers. Unlike these, its architectural expression is defined by traditional glass facades, Casa Naranja has a strong identity load based on the colour of its facade. The orange colour is the main component of the double skin colour palette that surrounds the building program contrasting in a monochromatic context. The chromatic expression is defined by 1980 aluminium slats that make up a range of warm colours (orange, yellow, vermilion red and coloured grey), corporate colours. This solution generates a pixelated image and promotes varied

perceptions. According to the point of view, it can be perceived more or less orange or more or less transparent. In relation to its night image, the lighting reproduces that distinctive feature chromatically. Consequently it maintains and reinforces the design criteria of becoming an orange, transparent and changing landmark according to the time of the day.



Figure 2: Case studies in Córdoba, Argentina.

## CONCLUSIONS

In current architecture, the study of the relevance of the chromatic expression and lighting corroborates the expressive and significant possibilities of light and colour. In the chosen international cases not only the use of the interaction between materiality, light and colour is recognized, but also the new technologies make it possible to innovate in architectural and urban design proposals.

In the case of Córdoba, excluding specific and significant cases in the current architecture, which appeal to the use of pigment colour, the new proposals of urban colour arise with the LED technology of RGB systems. In relation to the use of colour, the colour of the materials and the colour applied predominate, in some cases they are not recognized, except the exploration of materiality, light and colour as proposals related to the problem of contemporary architecture.

## ACKNOWLEDGEMENTS

We wish to express our gratitude to the Secretary of Science and Technique (SECyT), National University of Córdoba for the economic support to the Institute of Colour.

## REFERENCES

- Bahamón, A., and A. Álvarez. 2010. *Luz, color, sonido. Efectos sensoriales en la arquitectura contemporánea*. Barcelona: Parramón.
- Schindler, V. M., and M. Cler. 2017. New color-light-material tendencies in architecture and their impact on urban space. In: *Environmental colour design: theory and practice*, V. M. Schindler and Y. Griber, eds. Smolensk, Russia: Smolensk State University Press, 50-67.
- Torelló, E. 2015. El espíritu creativo del led. In: *Aplicaciones del LED en diseño de iluminación*. Madrid: Marcombo, 173-178.

# Colour harmony: landscape and city

**Larissa Noury**

Architect-colorist

President-founder “Couleur-Espace-Culture/Color-Space-Culture”, Paris, France

larinoury@gmail.com

## ABSTRACT

The harmony of colour is a universal, transcultural phenomenon. Applied either to the creation of natural landscape, of a city's visual image or the construction of new urban spaces, it represents a system of coded messages of the visual world that helps us understand, evaluate our surroundings and act in different contexts. The purpose of color design activity always has been the creation of man-colour-architecture equilibrium, which is based on the correlation between material and cultural particularities. As of today, the harmonies of colour of landscape and city, their nuanced and complex combinations, form a synthesis of knowledge and understanding of the environment. Created or appropriated by local people and full of subtleties, they have affected all human activities for centuries, even millenniums. Their impact is considerable, and by creating a pleasant and original setting they affect people's minds, change their mood and influence their behavior. In today's urban planning, architecture, visual art and communication, all aspects of creation are concerned. That is why our working method is at the crossroads of historical and scientific reasoning with an artistic touch: it embarks on an imaginary trip through time and space to explore the infinite universe of colour harmonies in order to enhance the image of different cultures (Bulgarian and Italian) and the representing cities (Plovdiv and Matera) around the world.

Our project method, based on a multidisciplinary approach, will be a possibility to involve all groups of professional architects and designers as well as concerned local citizens aiming to create an easily perceived and highly rich visual environment of the city including immaterial and ephemeral architecture and urban design. In the proposed project for the transformation of the urban environment, landscape and city, concerning the “image and identity of the city. Urban colour study for cultural capitals of Europe 2019: Plovdiv (Bulgaria) and Matera (Italy)” we offer a mobilization of different cultural symbols as a presentation and branding of Plovdiv and Matera specific images to internal and external audience: local public, visitors of the cities, national and international tourism organizations etc. Chromatic study of natural landscape, of the inhabited spaces as well as knowledge of the local historical heritage are fundamental to developing a strategy in reconstruction, restoration or rehabilitation. Our method and the results of investigations devoted to the colour image of the city will be an indispensable part for strategic plan of urban environment of the cities and will be an important information for architects, urban and landscape designers and artists.

**Keywords:** *color harmony, architecture, art, chromatic study, urban environment, image of the city*

## INTRODUCTION

According to our conception all urban cultures has experienced its development through natural environment, landscape particularities, light and colour, philosophy and religious symbols, its associations with colour system of natural world and local materials. Among the factors that determine the colour image and identity of the city is the natural phenomena. The analyses of different cases of natural and build environment show that regional light climatic and natural (mineral, water and vegetable) conditions have important influence on formation of chromatic palette of local architecture of the cities.

## EXPERIMENT

A profound analysis of colour environment and existing situation is of prime importance in our investigation. We can represent the theoretical model of colour image of the city as a system of two structure-coordinated parts: “chromatic tissue” (the chromatic palette of ensemble of ordinary buildings) and “chromatic frame” (colour palette of unique buildings). Then, when we are analyzing a particular site, we apply a Jean-Philippe Lenclos’ approach of *Geography of colour*, which is not subjective but objective, based on meticulous examination of the local colour harmonies and materials (Lenclos 1989, 1991).

Chromatic study of inhabited spaces as well as knowledge of the local historical heritage are fundamental to developing a strategy in reconstruction, restoration or rehabilitation. The method and the results of investigations devoted to the color image of the city will be an indispensable part of the training of architects, urban and landscape designers and artists. An urban colour reflection will allow not only a global vision of city’s territorial but also the harmonization of its centers with devices and industrial areas. The harmony of the urban landscape and its color consistency will be composed of various elements —architecture, landscape features and the “fifth façade”, street design and lighting at night— to form an entity. The synthesis resulting from the chromatic study of the city will offer specialized and streamlined pallets and become a simple and fundamental tool of work to be able to form a harmonious whole while respecting freedom of expression and the choices of the owners. The determination of chromatic harmonies as an essential stage in each project will offer to architects and residents a wide variety of solutions whenever new diverse ideas and proposals will give a creative, innovative and personified character to the image of the city. The colour in the townscape along with scale, form, light and texture plays a significant role in the acceptability and success of its development. Using colour with rigour and subtlety in the domains of the chromatic restoration of the urban heritage as well as in the contemporary architecture can help to alter perceptions of scale and mass and assure the integrity of surrounding buildings, streetscape and public places.

The knowledge about existing “environmental colour strategies”, about different colour group and visual harmonisation, needed to make urban space more comfortable and visually balanced, is an important theoretical base for practical experience.

Colour harmonies and its classifications considered as indispensable for colour study of the urban space: buildings, equipment, and the transport infrastructures. An environmental approach of urban colour design should not be seen separately but simultaneously with other design principles:



townscape character, public realm, movement and legibility, sustainable development, diversity and adaptability.

### The color image of Matera

The mineral colors of Matera represent, in a way, the symbol of rural culture and natural landscape. The city still manages to maintain its ancient traditions. The highest expression of rock art that developed in the Matera region can be found in the numerous churches dug in the tufo, scattered over the high plateau or incorporated into the urban environment of the Sassi of Matera. If the exterior image is much nuanced, we can find beautiful polychromatic frescoes and contrasted composition inside of those caves: the ancient Rupestrian churches have beautiful polychromatic frescoes.



Figure 1: The chromatic and geographical properties in image of the city of Matera composed by natural nuances (outside) and colors of Byzantine frescos (inside).

The color image of the city is rooted in its geographical space, but changes over time: its modifications have always been due to the evolution of architectural and urban planning of the city and are still constantly changing. If all the visual elements of urban space and land territory compose the integral image of the city, the color remains an essential part of the architectural, cultural and social heritage. In Matera we should study the palette of cave churches richly decorated in frescoes which have been painted by Basilian monks during the Byzantine Empire. It will be important to find the harmony inside of the churches (*chiese rupestri*) which are faded frescoes painted between the 8th and 13th centuries in order to offer a new interpretation of this palette for new constructions.

Today, a city, a town, aspire to offer its inhabitants a high quality of living environment while respecting its geographical properties, landscape and architectural culture of their own. This is why the debate on the sustainable town must include a chromatic environmental strategy. As of this moment, designing color in the towns and cities is a substantial part of new planning ideas and urban innovations.

The intelligence in the choice of color codes and chromatic harmonies can revitalize urban space by promoting a sense of security and serenity among citizens. It results in the ecology of color as a major component of an environmental project and has to be included in the global project of sustainable development of town and city. This approach earns the esteem of architects and designers for whom it seems obvious. It allows updating the knowledge on visual qualities of the city and its local characteristics with the *in situ* study of existing colors, their synergy, but also through analysis of key harmonies of each place, and environmental design that study a color interaction with

architectural forms and urban composition. It identifies the “genetic heritage” and creates visual palettes respecting the “spirit of the place”.

We will identify the beautiful harmonies of the Sassi and the Park of the Rupestrian Churches of Matera, which is considered as the most outstanding intact example of a troglodyte settlement in the Mediterranean region, perfectly adapted to its terrain and ecosystem. Color image of this settlement from the Paleolithic will help us illustrate this significant stage in local history.

### The color image of Plovdiv

The image of Plovdiv is more active on exterior. The visual environment of this Bulgarian city, considered as an oldest city of Europe, is far more complex. It has around 6,000 years of history so its image is chromatically more rich thanks to different historic layers. These layers range from traces of a Neolithic settlement found in the location of the current city, through Roman constructions, Bulgarian, Ottoman and Byzantine empires buildings, to recently restored painted streets demonstrating the Bulgarian Renaissance architectural style in Old Town. It is important to create an urban promenade gradually showing this complex image of the city, which obviously should be protected as a value of historic interest.



Figure 2: The chromatic and geographical properties in image of the city of Plovdiv composed by natural nuances and colors of from traces of a Neolithic settlement found, Romans constructions, Bulgarian, Ottoman and Byzantine empires buildings, as well as Bulgarian Renaissance (outside and inside).

### Comparative method of color images of Matera and Plovdiv cities

We will identify local palette and interest for applied craft and art and see how their graphic particularities, colors and patterns could inspire the projects of decorative urban patterns and sets of color for new design approach using local traditions. Our approach can be considered as a social because it takes into account the preferences of the city’s population. Our aim is also to create for both of the future European cultural capitals (Plovdiv and Matera) “a bridge” between “old color” in the cities’ environmental conceptual approaches and modern architectural color design. The harmonization of cities centers with their peripheral and industrial areas as well as their landscape, the development of their dominants or visual accents will help break the feeling of isolation and of disproportion. This environmental strategy will allow us to assure the continuity in the perception of those cities: analyze the overall image of the city and of each of its neighborhoods, districts and buildings, even including the design of street furniture, landscape qualities and setting of artificial lighting (Noury 2008).

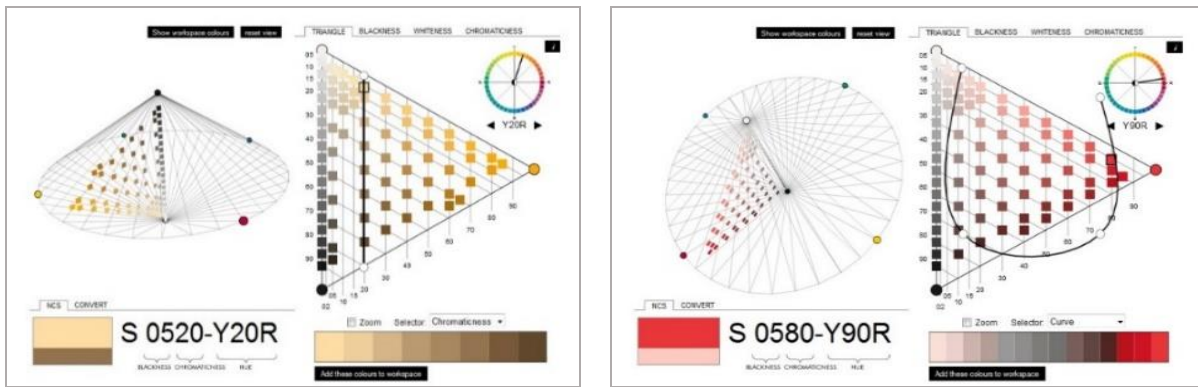

Figure 3: The chromatic study of existing color palette with Natural Color System identification.

All this should have a color consistency in order to form a harmonious urban area. As a visualization of an ecological system, this strategy will prevent cases of visual pollution (which makes no less damage than those of air, water or noise pollution), but equally help restore some past mistakes and upgrade the ancient heritage by harmonizing it with contemporary interventions. It will create an environment of good chromatic quality for new neighborhoods by integrating new national and international cultural contributions, and therefore leaving the door open to creation. Urban color, rich and complex, lively and full of meaning will participate in the image of Plovdiv and Matera at the beginning of 21st century, thus becoming more sensitive and human. Chromatic study of inhabited spaces as well as knowledge of the local historical heritage are fundamental to developing a strategy in reconstruction, restoration or rehabilitation. Our method and the results of investigations devoted to the color image of the city will be an indispensable part for strategic plan of urban environment of the cities and will be an important information for architects, urban and landscape designers and artists.



Figure 4: The Colour Harmony software applied for chromatic study using Natural Color System identification.

Our mission is to conceptualize a chromatic scale plan of each city that responds to the request of the cities centers revitalization and allow the renovation of the existing façades that respects existing geographical and landscape context (Noury 2010). The proposed document with urban color palette will reveal a specific local character of the territory and take into account the architectural features of previous epochs. This mission will include three main areas:

- 1.1. Analysis of urban and historical part of the city.
- 1.2. Regional and landscape analysis.
2. Conceptualization of urban morphologies: operational plan.
3. Definitions of chromatic harmonies and presentation of the accomplished work.

Our project method, based on a multidisciplinary approach, will be a possibility to involve all groups of professional architects and designers as well as concerned local citizens aiming to create an easily perceived and highly rich visual environment of the city including immaterial and ephemeral architecture and urban design. Graphic representations using digital imaging tools with NCS system will be proposed to express and communicate different local effects (light, climate, landscape ambiance, etc.) in the context of urban and architectural project (ANAH 2015).

This document provides guidance for everyone considering or proposing urban development, including landowners, property owners, developers, agents, advisers, architects and landscape architects. It is also targeted at those with responsibility for setting the framework for development and for making decisions about individual planning applications. This includes planning staff and their colleagues in local authorities.

The guidance in this document will help those who value and care for cities popular area to ensure that future developments contribute to the sense of place.

## REFERENCES

- ANAH (Agence nationale de l'habitat, France). 2015. <http://www.centres-bourgs.logement.gouv.fr/etudes-chromatiques-a88.html>
- Lenclos, J.-P. 1989. *The geography of color*. Tokyo: San'ei Shobo Publishing Co.
- Lenclos, J.-P., and D. Lenclos. 1991. *Les couleurs de la France: maisons et paysages*. Antony: Éditions du Moniteur.
- Noury, L. 2008. *La couleur dans la ville*. Paris: Éditions du Moniteur.
- . 2010. *Symbolique. Ville en couleurs*. Paris: Éditions du Huitième Jour.

# Colors in the landscape of Buenos Aires

**María Luisa Musso**

Universidad de Buenos Aires, Facultad de Arquitectura, Diseño y Urbanismo,  
Programa de Investigación Color, Buenos Aires, Argentina  
colormlm@gmail.com

## ABSTRACT

Buenos Aires is well known for the cultural value of its trees, part of the urban ecosystem intimately related to the inhabitants life. For the inhabitants of city centre in particular, the trees are the most conspicuous elements of the vegetable kingdom. They grow for the ornamentation of the public spaces and for shade and shelter, differing in size, shape and color in different seasons of the year. These paper refer only to the trees that produce changes in the appearance.

**Keywords:** *trees, city ornament, urban ecosystem, urban landscape, color in nature*

## INTRODUCTION

The color of a city is not limited to the inherent color of the facades of their buildings. It must be considered the perceived color in all its complexity and all the elements which form the urban landscape, as buildings, equipment, vegetation. From this chromatic range it is possible to extract part of the essence of the city. Color is expressed in all aspects of a city. Among them the landscape light, the strong contrasts or chiaroscuro. With regard to vegetation, important areas of Buenos Aires show modified the appearance by the trees in different seasons of the year. They contribute to the conservation of our cultural heritage.

At this conference, with the presence of participants from all over the world, it seemed right to talk about the trees that ornament the city, since they will find them on their tours through all the streets and parks.

The inhabitants of Buenos Aires love flowers, seen in the single-family houses and in the entrance of the apartment buildings. That is why they also enjoy the gardens of the city integrates in the urban set and the flowering trees in sidewalks, boulevards, squares and parks.

According to the urban tree census presented by the Government of the city of Buenos Aires, based on the survey carried out by the Faculty of Agronomy, University of Buenos Aires, the sidewalks of the city currently have 370,000 trees and there are also another 60,000 copies in green spaces such as parks, squares and boulevards. For 2019 it is thought to be able to plant 12 thousand

trees. The goal is to reach in the future 100,000 in green spaces and 420,000 in sidewalks. Among the 423 species that grow in Buenos Aires streets, the white ash (*Fraxinus pensylvanica*, called *fresno* in Spanish) has a 35% stake.

From the plan of trees of the city, the Government of Buenos Aires issued a report detailing the trees suitable for planting in the different paths, according to the width of the trunks and that of the sidewalk (Messore 2011). And they remembered that only the Buenos Aires government can carry out the plantations.

Buenos Aires is well known for the cultural value of its trees, part of the urban ecosystem. Trees are a fundamental part of the green city that continues to be built. They offer many benefits: provide shading from the sun, reduce traffic noise, they help purify the air, and environmental pollution. In a city of the magnitude of Buenos Aires they offer a valuable environmental resource, with several benefits for a higher quality of life to its inhabitants. May provide them with the opportunity to recover from daily stress.

Selection of urban trees corresponds to various criteria. From the ornamental point of view, it has to be considered the shape of the crown, foliage color, the characteristics of their flowers and fruits. In addition, its spread, longevity, type of growth, climatic and soil requirements, pest and disease resistance. According to health considerations the allergenic aspect also has to be considered.

Aesthetic benefits of trees relate to the possibility to see colors, structures, shapes and densities. Most of this aesthetic experience is subjective, and impacts on mental and emotional states of people (Tyrväinen et al. 2005).

The color that we perceive in nature is influenced by the intensity, angle and composition of the illumination. In the case of flowers, differs also from flower to flower, from tree to tree of the same species and also from the site where they grow and the richness of the soil.

Color makes only a superficial impression upon a soul hardly developed to sensitiveness, while when that impressions reach highly developed people is communicated immediately to the senses (Kandinsky 1946). Color is fundamental to an understanding of our world and profoundly affects our daily lives. Color represents the first visible item. It is the subject of a complex cultural assessment.

When we look at an object located in an environment, the colors of both these components should be considered, since the object transmits a message and the environment has a specified identity. Sensorial cells transducer these stimuli and send these signals to different brain and body areas.

Each of the factors that concur to a good environmental quality and to visual aspects should be addressed. Appears thus necessary a really “human focused” methodology which bonds knowledge from the different fields to produce an environment able to satisfy those several needs.

The visual appearance is in many cases, knowledge through which an object is characterized or recognized as having attributes such as size, shape, color, texture, shine, translucency, opacity (Lozano 2015).

The ornamental aspect is given by numerous features that together or separately, set the total value of ornamentation of a tree, those that predominate in the appreciation of this character are: the color of leaves and flowers and, in some cases, the fruits.

The color of the bark occasionally helps to highlight the attractive conditions of a species, as can be seen in that of drunken sticks (*palo borracho*, Floss-silk tree) and also the colors of the platanus bark, but usually these references are merely secondary, and only occasionally can be used to appreciate the decorative quality of a species.

Regarding the color there are trees appreciated by the attractiveness of flowers in spring and summer or foliage in autumn or winter, while others stand out in both aspects.

The urban landscape show modified the appearance by the trees in different seasons of the year. It is especially in spring and summer when important areas of Buenos Aires have modified their color due to the presence of ornamental trees with its flowers coloring the city. However, also in autumn and winter the streets are colored by the leaves of the trees. The trees mark the seasons and with their aesthetics they relate to people who experience different colors.

Nearly 300 types of trees were detected in the city, but those who have been included in this paper refer only to the trees that produce real changes in the appearance of the city of Buenos Aires in different seasons of the year.

For instance, the *ceibo* or *bucaré* is a tree originating especially from the Argentinean coastline that has beautiful red flowers. Its flower was declared the national flower of Argentina. But it is seen only in some parks in small quantities.

## DESIGN OF THE CITY'S OPEN SPACES

At the arrival of the French landscape architect Jules Charles Thays (disciple of Édouard André, French landscape architect and botanist) to Argentina there were only 1,100 trees in Buenos Aires. He was named the city's Director of Parks & Walkways in 1891. In the competition to qualify for this position he wrote: "The man, especially one that works, has need for distraction and is there something healthier, nobler, truer, than the contemplation of the trees, the beautiful flowers, when they are arranged with taste? The spirit then rests, and the aspect of beauty, of purity, produces an immediate effect on the heart".

This position gave him significant influence over the design of the city's open spaces. Major projects included tree planting along streets, remodeling and designing public plazas and walkways as well as designing completely new parks and expanding older ones. He traveled around the country looking for species that would serve to decorate streets, parks and squares. From the north of Argentina, he brought pink lapacho, floss-silk tree, tipa tree and jacaranda. Around 1991 there were in the city some 65,000 trees (Berjman 2002).

## TREES OF BUENOS AIRES

This research includes an empirical observation collecting observable data and photos taken in the mentioned places.

**Pink lapacho** (*Tabebuia avellanedae*) is a native tree of America, widely planted as ornamental tree in landscaping gardens, public squares and boulevards due to its impressive and colorful magenta flowers, though exceptionally white. Flowering season is September, before the new leaves appear, but the ephemeral spectacle lasts a short time (Figure 1).

**Floss-silk tree** (*Chorisia speciosa*), called *palo borracho* in Argentina (drunken stick) because its trunk is bottle-shaped, is native to Argentina and Brazil. Its trunk, bulging in its lower third, measuring up to 2 meters in girth, which serve to store water for dry times. It is studded with thick conical prickles.

Trees bloom in spring. The pink flowers are very showy and remain for a long period. In winter, the fruits open, showing the silky white cotton which surrounds the seeds (Figure 2).

**Melia azedarach** (called *paraíso* in Argentina), well known as Persian lilac, is native to India and Pakistan. There are about 35,000 trees in the streets. Flowers are showy, fragrant, numerous on slender stalks, white to lilac. In winter, no leaves remain, just the “China berries” fruit, small, yellow, in cluster that are also very ornamental (Figure 3).

**Tipa tree** (*Tipuana tipu*), known as rosewood, is a South American tree. Very parasol-like shaped and highly branched, it provides shade and a nice cooling effect in the summer heat. It is appreciate also for its magnificent blooming yellow. It is in full bloom in December, when the yellow of the flowers mix with the green of the leaves, and upholster then with gold, the lawns, driveways and sidewalks. They lose its leaves tardily in winter. It is one of the most conspicuous and well known trees of our flora (Figure 4).

**Jacaranda** (*Jacaranda mimosifolia*), a sub-tropical tree native to South America that has been widely planted elsewhere because of its beautiful and long-lasting light blue flowers, is in bloom all over the city. They appear in spring and early summer, the profuse flowering of these trees grace the plazas, parks, line the major avenues and streets. There are more than 11,000 trees in the city and continue to be planting elsewhere. The flower of jacaranda is the flower representing the city (Figure 5).

## TREES IN AUTUM

**White ash** (*Fraxinus pensylvanica*, *fresno americano* in Spanish) is a tree from the temperate forests of North America, Asia and Europe. The foliage, glossy green turns to bright yellow in autumn. The tree female have fruits crushed and provided with a wing, that is green in spring and brown in autumn. It is the species with the largest presence in the streets of the city, with more than 143,000 trees (Figure 6).

**Liquidambar styraciflua** is a tree from southern USA, Mexico and Guatemala. Liquidambar comes from liquid and amber, alluding to the aromatic resin obtained from its bark. The tree is a symmetrical shape. The fruit is a multicapsular spherical head formed by numerous capsules each with two seeds, and hangs on the branches during the winter, remaining on the tree for quite a long time. The leaves have five to seven lobules sharp; the upper side is bright dark green and the lower, clearer. In autumn they turn yellow to red and burgundy coloring the streets (Figure 7).

**Platanus acerifolia** (*plátano*, in Argentina), is considered a hybrid between two species: *Platanus orientalis*, of Eurasian origin, and *Platanus occidentalis*, of American origin. It is a tree that can reach above 40 meters high, providing a dense shade. There are about 35,000 trees in the streets. It bright green foliage turns to light brown in autumn. The leaves have pubescent underside fixing atmospheric dust particles, so that their action is significant decontaminant, but these wear off by late summer. The ripe fruit 2-3 cm in diameter consists of a dense spherical group with numerous stiff hairs that wind helps dispersal. The pollen from its fruits produces allergies (Figure 8).



**Ginkgo biloba** is the only representative of the Ginkgoaceae family, and is the oldest species of terrestrial tree. It originated about 300 million years ago. Very widespread in the age of dinosaurs, it is described as “living fossil”. Highly appreciated for its beauty and also for its resistance to pollution and predatory insects, ginkgo is currently growing worldwide. Can live up to 4,000 years. The ginkgo trees we have today exist thanks to the efforts of the Tibetan and Chinese monks who recognized the value of this rare tree and began to cultivate it. A Ginkgo biloba located a kilometer away from the explosion of the atomic bomb that in 1945 turned Hiroshima into ashes, sprouted. An international initiative, commanded by the UN, was concerned with conserving the seeds of that specimen and distributing them in other countries. The arrival of the seeds in Argentina was from the Botanical Garden of Hiroshima. The alternate, bilobed, fan-shaped leaves are of a beautiful light green color. In autumn the leaves turn to a beautiful and bright yellow color very decorative (Figure 9).

Buenos Aires is a green city. The landscape is considered a cultural construction. There is a sense on the need to enjoy the color in nature that surrounds us. It is very impressive how the color of flowers, leaves, trunks and its branches modifies the urban environment in different seasons of the year.

Flowers in Buenos Aires are so important that one imposing sculpture of a stainless steel flower more than 20 meters high dominates the United Nations Plaza with its presence. Called *Floralis generica*, It was donated to the city by its author, the Argentine architect Eduardo Catalano (Figure 10). It is the first sculpture in motion controlled by a hydraulic system and photoelectric cells, ready to open at dawn and close at sunset.

## REFERENCES

- Berjman, S. 2002. *Carlos Thays: sus escritos sobre jardines y paisajes*. Buenos Aires: Ciudad Argentina.
- Kandinsky, W. 1946. *On the spiritual in art*, ed. H. Rebay. New York: Solomon R. Guggenheim Foundation.
- Lozano, R. D. 2015. *La apariencia visual y su medición*. Buenos Aires: Grupo Argentino del Color and Dunken.
- Messore, I., ed. 2011. *Haciendo verde Buenos Aires: El libro verde*. Buenos Aires: Ministerio de Desarrollo Urbano.
- Tyrväinen, L., S. Pauleit, K. Seeland, and S. de Vries. 2005. Benefits and uses of urban forests and trees. In: *Urban forests and trees*, C. Konijnendijk et al., eds. Berlin: Springer, 81-114



1: Pink lapacho (*Tabebuia avellanedae*)



2: Floss-silk tree (*Chorisia speciosa*, palo borracho)

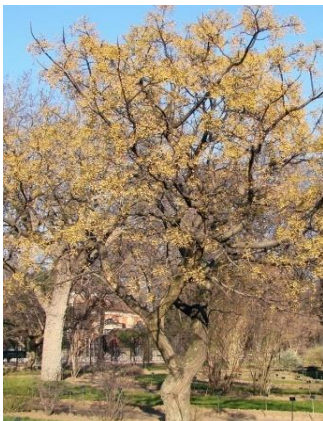

3: *Melia azedarach* (paraiso)



4: Tipa tree (*Tipuana tipu*)



5: Jacaranda



6: White ash (fresno)



7: Lyquidambar



8: Platanus



9: *Ginkgo biloba*



10. *Floralis generica*, by Eduardo Catalano

# Architectural landscape built by Francisco Salamone. State of conservation of tiles located in Azul city, Buenos Aires province, Argentina

Anahí López<sup>a\*</sup>, Alejandro R. Di Sarli<sup>b</sup>, Luis P. Traversa<sup>c</sup>

<sup>a</sup> CICIPBA-LEMIT, UTN-FRLP (LeMAC), La Plata, Buenos Aires, Argentina

<sup>b</sup> CIDEPINT, CICIPBA-CONICET-UNLP, La Plata, Buenos Aires, Argentina

<sup>c</sup> CICIPBA-LEMIT, La Plata, Buenos Aires, Argentina

\* lopezanahi2002@gmail.com, colores@lemit.gov.ar

## ABSTRACT

Francisco Salamone's buildings, located in Buenos Aires province, Argentina, have a patrimonial value and fundamentally represent his ability to merge the knowledge related to design and materiality. The present paper shows the characteristics of the tiles found in San Martín square, at Azul city, by evaluating the mortars used for its construction. From these results, the original value of parameters related to aesthetic aspects such as color, yellowness index, gloss and roughness was obtained. This knowledge will allow reproducing the original pieces needed to carry out the restoration of the square and the valorization tasks. In Azul city, one of these squares was developed as a recreational space in which the floors were made with tiles specifically manufactured for such application. This specificity involved fabricating tiles with a rhombic shape, and colors with low saturation values, i.e. in the gray scale.

**Keywords:** *historic architectural landscape, Francisco Salamone, San Martín square, Azul city, Argentina*

## HISTORY AND IMPORTANCE OF SALAMONE'S WORK

Francisco Salamone (1897-1959) —graduated as engineer architect (1920) and civil engineer (1922) at the National University of Córdoba, Argentina— was one of the professionals who, during Manuel Antonio Fresco government of Buenos Aires province (1936-1940), designed and executed a set of public buildings and some few private ones in the region. The buildings were intended for public administration (town councils), economic activities (slaughterhouses), public services (cemeteries), and recreational spaces (Novacovsky et al. 2001, Traversa 2016). The planning of the works was conceived with the intention of encouraging the use of public space, among other causes with clear political objectives (Traversa 2016). With the passage of time, his buildings have been recognized as

historical heritage (Novacovsky et al. 2001, Longoni and Molteni 2004). The "futuristic and technological" imprint represented in his work, was manifested by the modern movement, mainly through the monumentality of Art Deco. This architectural trend was materialized with concrete, which offered the aesthetic qualities that the designs demanded. Concrete and the constructive techniques used to obtain clean and pure geometric shapes were innovative at that time in the province of Buenos Aires (Novacovsky et al. 2001, Longoni and Molteni 2004, Traversa 2016).

It is worth noting that Salamone introduced the reinforced concrete, and in particular casting concrete, in the buildings that he executed in the province of Buenos Aires. This material and its technology were innovative at the beginning of the 19th century. In addition, the use of this material allowed the execution of public buildings with a particular imprint on the design and fundamentally in the execution of towers, crowned in almost all cases by a clock. This situation is particularly verified in the buildings of municipal palaces (at Guaminí, Pringles, and other cities), and in municipal abattoirs in which he executed high identity towers that often reproduce the knife used by the slaughterer to kill the animals.

The execution of this set of buildings in the Buenos Aires pampa modified the traditional landscape with modern constructions. Salamone used the reinforced concrete in urban ornamental furniture and replaced the marbles in stairs and steps. In addition, he replaced the simile stone with a white cementitious matrix. Each casting element was made in a central plant and transferred to different locations by train. The square of Azul city is a characteristic example of these elements, that he used in most locations (Figure 1). It can be stated that all his works produced modifications of the urban landscape. In some cases he used white cement exclusively in the outer layer and gray cement in the inside one, due to economy reasons.



Figure 1: Central square and view of the Azul city hall (Buenos Aires province, Argentina). The central fountain contains the monument to José de San Martín. The rhombic tiles arranged in a zigzag pattern simulate the movement of the waves, by an optical effect. © 2015 Sebastián Marquez. All rights reserved.

Located at 300 kilometers southwest of Buenos Aires city, Azul is a city in the center of Buenos Aires province, where approximately 70,000 inhabitants live. It is one of the populations benefited by this modern heritage with, on the one hand, two buildings —the cemetery and the slaughterhouse—, and on the other, two public spaces —the park portal and the San Martín square. First it was called Mayor square and then Wagons square; for half a century it was named Colón square. "When the tasks of remodeling the square through the plans of architect Salamone begin, and a monument to general San Martín is erected in a fountain with light-water games, the name is changed to San Martín square. The limits are defined by the city hall, the Spanish club —which opened in 1897—, and the cathedral —Our Lady of the Rosary—, inaugurated in 1906, as the most relevant buildings surrounding the square. In the layout is perceived that the encounter of the compositional axes, which includes the monument to San Martín with the fountain, determines one of the main directions of the square that, in addition, is linked to the vertical axis of the municipal tower" (Longoni and Molteni 2004, our translation).

The tiles used in the sidewalks of the square and pedestrians paths are located forming bands in zigzag, which causes an optical effect. The zones are well differentiated by the forms, i.e. straight or curved —depending on whether the banks occupy the perimeter or the internal paths— and on the other straight lines (lateral) and circumferences (interior). The square is also equipped with urban furniture (benches) and lighting (lamp posts) manufactured, like the planters, with reinforced concrete. The works of Salamone were inaugurated in 1939 and the tiles here studied were rescued in 2003. The same typology of tiles was used in the square located in Coronel Pringles city, but in a walk near the city hall of Pellegrini they differ in both, typology and color.

### ASSESSMENT OF THE TILES USED IN SAN MARTÍN SQUARE, AT AZUL

The assessment of the square state showed numerous pieces missing (Figure 2, left). In addition, it was possible to appreciate the accumulation of dust that darkened the lighter tiles (Figure 2, center) and the breakage of others that obstructed the transit on them (Figure 2, right). The design is made up of rhombus-shaped tiles. Three samples were studied: A (light), B (grayish) and C (dark) of 25.5 cm side and a total thickness of 2.5 cm. Each tile has been manufactured using two types of mortar, well differentiated by the change of color: the surface (s) exposed to the weather —of A, B or C color—, and the lower part (l) in contact with the base (subfloor). According to the visual inspection, the A and B tiles surface have a rougher texture than the C tile.



Figure 2: Missing tiles (left), dust accumulation (center), broken tiles (right). © 2003 Sebastián Marquez. All rights reserved.

## METHODOLOGY TO EVALUATE THE AESTHETIC ASPECTS

### Color, yellowness index and gloss studies

Color is a sensory perception that coexists with three fundamental elements: an object, an illuminant and an observer (Lozano 1978). To evaluate it, the CIELAB model will be used, which is defined by three variables:  $L^*$ ,  $a^*$  and  $b^*$ , where  $L^*$  is the lightness that indicates the surface clarity (high  $L^*$  values) or darkness (low  $L^*$  values). This variable is the most representative of the tiles color since they are predominantly in the gray scale (López and Di Sarli 2015).

The  $a^*$  and  $b^*$  coordinates are located in a plane perpendicular to the variable  $L^*$ . The  $a^*$  axis represents the red-green variation, being positive for the first ( $+a^*$ ) and negative for the second ( $-a^*$ ), while the  $b^*$  axis represents the yellow-blue variation, being positive for the first ( $+b^*$ ) and negative for the other ( $-b^*$ ). These values show the small saturation of the pieces here studied because the values tend to be low. However, an increase of the  $b^*$  variable in a clear color could mean that it turns yellowish, in such a case, the yellowness index (YE), a parameter relating  $L^*$  and  $b^*$  should be analyzed. If the value is positive it tends to be more yellowish but if is negative it will be more bluish.

Besides working with the CIELAB model, a BYK-Gardner spectrophotometer calculating the yellowness index and providing the gloss (G) was used. Gloss is also a visual perception resulting from the evaluation of an illuminated surface in such a way that the more direct light is reflected, the higher is the obtained gloss perception. For example, the gloss value obtained with mortars in contact with a highly polished surface measured 15%, while with steel (smooth) and wood (veined) it decreased to 1.5%.

### Texture studies

Roughness is a parameter that defines the geometry of a surface. Among others, an indicator can be the average arithmetic roughness ( $R_a$ ) measured in micrometers ( $\mu\text{m}$ ) (see equation in Figure 3), which is proportional to the area enclosed between the midline and roughness profile, and calculated by the Hommel Tester T1000 E roughness meter. Some examples of roughness are the following: glass =  $0.05 \mu\text{m}$  (similar to the ceramic tile surface =  $0.06 \mu\text{m}$ ), steel =  $2 \mu\text{m}$ , wood used for the formwork, between  $7 \mu\text{m}$  and  $10 \mu\text{m}$ .

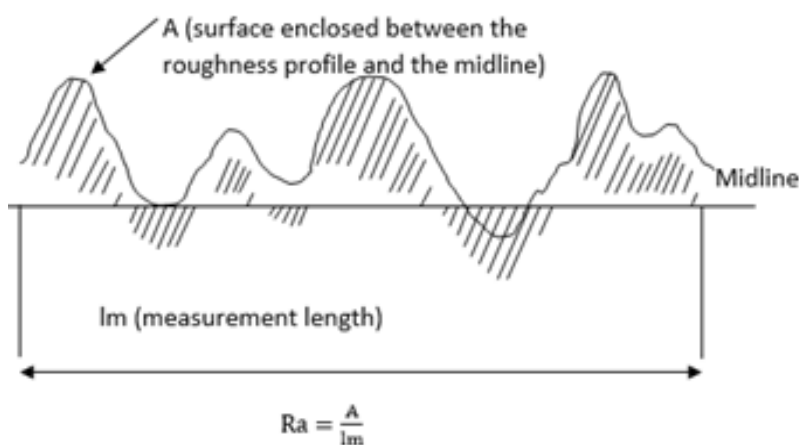



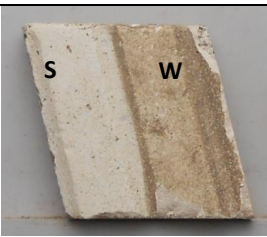

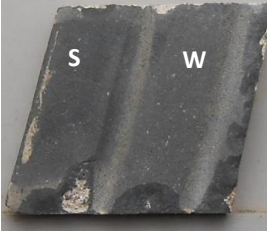

Figure 3: Roughness profile.

## EXPERIENCES AND RESULTS ON THE TILES

The state of conservation of tiles (SC) was recorded by means of photographs taken inside a visual inspection chamber so that all the images were captured under the same operative condition. Thus, after applying sandblasting (S) or washing (W) methods to recover the original color, the photographs were compared again and the differences were associated to the quantifiable values. Figure 4 shows the different states: SC, S and W.

Figure 4 presents the characteristics of the aesthetic aspects in the SC, S and W situations. The state of conservation of tiles was different for each of them. The A tile —lighter— presented values of  $L^*$  close to 60 units, very different from B and C tiles —the darker ones— in which the values of  $L^*$  fell to 45 and 40 units, respectively. In B and C tiles, the values of the  $a^*$  and  $b^*$  coordinates were very small but somewhat larger than those of  $b^*$  (14 units) if A tile is observed. This is due to the dust adhering to the surface. The gloss was between 0.8% and 1.0%. The C tile showed low roughness ( $R_a$ : 4.2  $\mu\text{m}$ ), unlike A and B tiles (14  $\mu\text{m}$ ). With the S method it was possible to remove the surface evaluated according to SC, and thus discover the mortar mass color. In addition of being free of dirt, it is evident the lightness recovery in A tile, and how B and C tiles darkened. Note that the yellowness index in A tile was high and when it recovered lightness it dropped to 22 units. However, they it was not possible to maintain the gloss and roughness (its records were very random).

Finally, in the tiles that were washing (W), the results reached were between the obtained values according to the tile conservation state and the sandblasted method, although the gloss and roughness could be better controlled without discovering the mortar mass color.

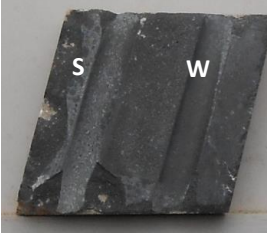
	State of conservation (SC)	Recovery methods (S and W)	Color			YE	G	Ra	
			$L^*$	$b^*$	$a^*$				
A Tile			SC	59.8	4.7	14.4	35.6	1.0	13.8
			S	78.0	1.5	9.6	22.2	1.5	11.2
			W	66.9	4.1	15.1	36.7	1.5	9.1
B Tile			SC	45.6	0.4	5.4	22.1	0.7	13.5
			S	35.8	-0.7	-1.6	-10.1	0.5	20.6
			W	39.7	-0.5	-0.1	-1.1	0.8	10.8
C Tile			SC	41.6	-0.7	-2.5	-12.0	0.8	4.2
			S	31.6	-0.4	-1.3	-6.5	0.4	19.1
			W	33.5	-0.4	-2.5	-11.7	1.3	3.4

S: sandblasting. W: washing.  $L^*$ ,  $a^*$ ,  $b^*$ : CIELAB units.  $YE_{313-98}$ : yellowness Index.  
G (%): gloss.  $R_a$ : arithmetic mean roughness. \* Average values

Figure 4: Images captured in the same observation condition. Aesthetic aspects: color and texture.

© 2017 Anahí López. All rights reserved.

## FINAL CONSIDERATIONS

The works of Francisco Salamone located in the province of Buenos Aires, Argentina, have a patrimonial meaning and fundamentally represent the ability of a professional who managed to merge the knowledge related to design work and materiality. Surely this was possible due to his complete professional training and dedication to design, planning and execution of his buildings. Azul city, among others, has been benefited by these works, which must necessarily be protected.

The present work shows part of the methodology applied at the LEMIT for determining the characteristics of tiles in the central square located in the city of Azul, province of Buenos Aires, from evaluating the mortars used in its manufacture. From the results, the original parameters related to the characterization of aesthetic aspects, such as color, yellowness index, gloss and roughness, were obtained. This will allow reproducing the original pieces necessary to carry out the restoration of the square and the valorization tasks.

## REFERENCES

- Longoni, R., and J. Molteni. 2004. *Francisco Salamone, sus obras municipales y la identidad bonaerense*. La Plata: Archivo Histórico de la Provincia de Buenos Aires Dr. Ricardo Levene.
- López, A., and A. R. Di Sarli. 2015. El color en el hormigón. *Color & Textura* 122: 20-24.
- Lozano, R. D. 1978. *El color y su medición*. Buenos Aires: Américalee.
- Novacovsky, A., F. Paris Benito, and S. Roma, eds. 2001. *Francisco Salamone en la provincia de Buenos Aires. Reconocimiento patrimonial de sus obras*. Mar del Plata: Facultad de Arquitectura, Urbanismo y Diseño, Universidad Nacional de Mar del Plata.
- Traversa, L. P. 2016. Evaluación de algunas estructuras que integran el patrimonio arquitectónico e ingenieril ejecutado en hormigón armado. *Hormigón* 55: 7-27.



# Postcards from chromatic places (from Golden, Colorado, to White Settlement, Texas)

Jada Schumacher

Fashion Institute of Technology, New York, USA  
jada\_schumacher@fitnyc.edu

## ABSTRACT

The paper features a design project I created titled *Postcards from chromatic places*. The project, in the form of postcards featuring color fields —visually inspired by the works of Josef Albers and Ellsworth Kelly— presents actual towns on the United States map (from Little Silver, New Jersey, to Ruby, South Carolina). The paper presents the design work coupled with research and short analysis of the social, cultural, and spatial significance of names of color towns in the American landscape. *Postcards from chromatic places* playfully voyages through the residues of color in the American cultural landscape and explores color's linguistic presence in the geography of the everyday.

**Keywords:** *geography, color and place, color and linguistics, United States, color naming*

## INTRODUCTION

The design methodology included:

- 1) combing the atlas to identify every town in the United States named with a word associated with a color;
- 2) choosing two color-named towns per state, often picking unusual choices from the vast assortment as opposed to the straight-from-the-crayon-box names;
- 3) pairing each color-named town with a specific Pantone Matching System hue;
- 4) designing 50 postcards using the colors of the chosen towns;
- 5) researching and analyzing the history behind the name of each town.

## RESULTS AND DISCUSSION



Figure 1: Color-named towns in the United States with their corresponding Pantone Matching System colors.

Below, towns listed are placed into categories by genesis of town name. The categories include: natural elements on site, people, another place, industry, human-created element on site or nearby, object in view, cultural, uncategorized/random, and unknown. An asterisk denotes that multiple reasons for town name have been found.\* Towns with multiple reasons are listed more than once. They are listed in every category that research suggests. As such, the numbers add up to more than 100 (as opposed to just 50 states × 2 towns for each state). As one would expect, much of the research depends on oral history, projections by the people, and similar.

Town name	Genesis of name
Blue Ash, OH	blue ash tree logs - building material for Carpenter’s Run Baptist Church on original site
Blue Earth, MN	“green” or “blue earth” translated from Dakota Indian word “Mahkaho”
Bluegrass, VA	bluegrass pastures
Blue Hill, NE*	hills of the Blue River
Blue Hill, NE*	hill that was perceived bluish in color
Butternut, WV	butternut trees (assume inspired name)
Cerulean, KY	River (originally black from black sulphur but, after the New Madrid earthquake of 1811, turned sky blue as contained chloride of magnesia) (a local legend)
Cobalt, CT	cobalt (nickel and gold on site as well)
Cocoa Beach, FL*	plants on site were considered but cocoa plant inspired name
Coffee Creek, MT	dark brown coffee-colored water
Cherryfield, ME*	cherry trees lining the river blossom in spring
Cherryfield, ME*	blueberry barrens (bright red in fall and look like cherry fields)
Coralville, IA	fossilized coral in limestone along river
Copperhill, TN	copper
Evening Shade, AK	“late afternoon and early evening shade” from pine trees on hill
Falun, KS	Falu/Falun red paint from Falun in copper mines of namesake town Falun, Sweden
Green Bay, WI*	algae caused stagnant muddy waters; translated by the French as “La Bay des Pauns”; the British changed the name to Green Bay due to dark green waters
Flint, MI	river rock bed Indians named “Pawanunking” inspired “Flint River; shortened later
Golden, CO*	gold, probably first named Golden City and shortened later
Gold Hill, NV	Chunk of gold in mound of earth
Grapevine, TX	wild mustang grapes
Hazel Green, AL*	green hazelnut trees
King Salmon, AK	red salmon; chinook salmon are “kings” due to large size (assume inspired name)

Lemon Grove, CA*	lemon groves (name chosen when citrus became major industry)
Little Silver, NJ	Little Silver Creek looked metallic
Lime, OR	limestone
Lime Kiln, MD	antebellum lime kiln
Maize, KS	corn (called “maize” in an Indian language)
Mud Lake, ID	shallow “murky water” of sand dunes of old lake in lava beds (“murky” because fowl stirred up the dirt -or- first cattle in morning got water while the rest got mud -or- persistent wind kept water muddy)
Pearl City, HI	oysters with pearls
Plum (Creek), PA	Plumb Creek (which joins Crooked Creek; “spiua-hanne” means straight in Delaware Indian language and translates as plumb)
Red Bud, IL	redbud trees
Red Hook, NY	red clay soil and peninsula of hook shape
Sage, WY	plant called Wyoming big sagebrush (which many native animals need to survive)
Silver City	ore had a “silver character”
Silt, CO	powdery soil
Sweetgrass, MT	plant called “sweet” grass (because it smells sweet for a long time)
Vermilion, SD	red (vermilion) clay along river
White Plains, NY	“white marshes” or “plains” translated from Indian “Quarropas” (assume in region)
Zinc, AK	zinc (and lead) made area a mining hub

Table 1: Natural elements on site.

Town name	Genesis of name
Blackfoot, ID	group of Indians seen so the area named Blackfeet (Blackfoot River derives from this)
Black Hawk, SD	Indian chief whose name translated as “Black Hawk” was namesake of nearby stream
Blacksburg, VA	Samuel Black bought land here
Blackshear, GA	General Blackshear
Brownville Junction, ME	mill owner and trader Francis Brown (nephew of Moses Brown) helped form the settlement
Dill City, OK	attorney David S. Dill did legal work to create town
Frost, MN	Chicago architect Charles S. Frost
Golden, CO	maybe after miner and businessman Thomas L. Golden; probably first called Golden City and shortened later
Green Bay, WI*	Winnebago Indians called ouinipeg meaning “the pay of the stinkards” by some settlers (possibly meaning a dislike of Indians); French settlers also nicknamed the tribe “Les Pauns” translating as “stinkards” and called the area a “nation of stinkers”
Gray Summit, MO	Daniel Gray built a hotel on the summit (which was the highest place on Missouri Pacific Railroad between St. Louis and Jefferson City)
Hazel Green, AL*	Hazel Green, the wife of first store owner and postmaster
Kelly, WY	local rancher and sawmill owner Bill Kelly
Orange City, IA	Dutch Royal family (the Royal House of Orange) was honored by Dutch settlers
Orangeville, UT	early settler Orange Seely (namesake of nearby town, Castle Dale); here named Orangeville to honor early settlers
Pepperell, MA	Sir William Pepperell, hero of the capture of Louisbourg in 1745
Pink, OK*	some early inhabitants who had “Pink” as a first or middle name (popular at time)
Powderly, KY	labor organizer Terrance V. Powderly
Red Cloud, NE	Sioux Indian leader Red Cloud (although area was inhabited by Pawnee/Otoe tribes and not by the Sioux)
Snowflake, AZ	William J. Flake bought the property to help Mormons colonize; Erastus Snow was Mormon apostle in charge
Red Level, Alabama*	store owner James Read of “Read’s Level” store; he said his name with the “a” silent
Violet, LA	Violet Blair, the wife of the developer of “Violet Canal”
Virginia City, NV	miner James “Old Virginny” Finney
White Settlement, TX	Caucasian people settled in region populated by American Indians
White Shield, ND	Arikara Tribe Chief White Shield

Table 2: People.

Town name	Genesis of name
Bowling Green, OH	Bowling Green, Kentucky where postal worker Joseph Gordon used to live
Bowling Green, OH	believed many settlers came from Bowling Green, Virginia
East Greenwich, RI*	Greenwich a borough in London
East Greenwich, RI*	a manor in Kent County England
Evergreen Park, IL	evergreen trees in a star-shaped park (the park took design inspiration from the urban planning around the Arc de Triomphe in Paris)
Gray Court, SC*	engineer, Mr. R. L. Gray so he would be reminded of Gray Court, New York, a place he thought most pretty in the state of New York
Little Silver, NJ*	17th century estate in Rhode Island where the settlers grew up
Northumberland, NH	Northumberland in England

Table 3: Another place.

Town name	Genesis of name
Cotton, GA	cotton because thought that the soil could produce that crop
Concrete, WA	Washington Portland Cement Company so named "Cement City"; Superior Portland Cement Company plant opened nearby so towns merged to make "Concrete"
Ivoryton, CT	ivory industry set up by family importing tusks for piano and organ keys
Parchment, MI	Kalamazoo Vegetable Parchment Company (old sugar factory made parchment paper)
Pimento, IL	name of a coal mining operation nearby where town inhabitants worked (debated)
Navy Yard City, WA	William Bremer bought land and sold to the Navy

Table 4: Industry.

Town name	Genesis of name
Bowling Green, OH*	a bowling green
East Carbon, UT	high school nearby for Carbon School District (land donated by Kaiser Steel mining company that had history of coal fabrication to run plants), and coal is made mostly of carbon; school assembly attendees at East Carbon Jr; high voted new school name to be East Carbon High School; when incorporated, town chose school as namesake
Cinnaminson, NJ	a trail named "Senamensing" by Lenni-Lenapetribes (sounds like Cinnamonsin)
Ecru, MS	first railroad depot's color
Olive Branch, MS*	crossing of several old Chickasaw Indian Trails nearby (first named Watson's Crossroad and then changed to Olive Branch)
Pink, OK*	town nearby named Brown so picked another color word, to follow the county's trendy "twin name fad"

Table 5: Human-created element on site or nearby.

Town name	Genesis of name
Cocoa Beach, FL*	woman randomly inspired by a box of Baker's Cocoa
Toast, NC*	assumed someone in Washington, DC was eating toast (the town was named by Washington, DC as town inhabitants didn't know what to name it)
Toast, NC*	shoobox on the shelf nearby held shoe labelled with the color "Toast"

Table 6: Object in view.

Town name	Genesis of name
Auburn, NH	"Sweet Auburn, loveliest village of the plain," the first line of a poem by Oliver Goldsmith titled "The Deserted Village"
Olive Branch, MS*	symbolism of a dove giving biblical Noah a branch as he left for sea
Peachum, VT	Polly Peachum, character from popular "The Beggar's Opera"

Table 7: Cultural.

Town name	Genesis of name
Cocoa Beach, FL*	empty tin box labelled “Baker’s Cocoa” in which mail was delivered
Cocoa Beach, FL*	hot cocoa supplied to passing sailors by an old woman along Indian River
Little Silver, NJ*	real silver money paid by Lenni-Lenape tribe to buy land from European settlers
Saltillo, PA	Mexican War Battle of Saltillo in October 1840

Table 8: Uncategorized.

Town name	Town name	Town name
Ashton, RI	Clover Lick, WV	Mint Hill, NC
Big Sandy, TN	Concord, DE	Moss Beach, CA
Blanco, NM	Cream, WI	Orange, VT
Buckskin, IN	Greentop, MO	Orchid, FL
Canary, OR	Greenwood, DE	Ruby, SC
Claypool AZ	Long Green, MD	Wildrose, ND

Table 9: Unknown.

Categories of genesis of name	Number of towns (out of 112)	Percentage (rounded to whole)
Natural elements on site	40	36%
People	24	21%
Another place	8	7%
Industry	6	5%
Human-created element	6	5%
Object In view	3	3%
Cultural	3	3%
Uncategorized/random	4	4%
Unknown	18	16%

Table 10: Summary of findings.

As mentioned above, an asterisk denotes that multiple reasons for town name have been found.\* These towns are listed more than once and are listed in every category that research suggests. As such, the number of towns adds up to 112 rather than 100 (50 states × 2 for each state).



Figure 2: Iowa postcard (Coralville and Orange City) and Washington postcard (Concrete and Navy Yard City).

Not surprisingly, results show that the largest percentage of color named-towns are derived from hues of the natural physical landscape (such as the river color in Coffee Creek, MT). In addition, many settlements honored people at the time of the town's inception. Particularly surprising and controversially today, White Settlement, TX, was named because Caucasian settlers created a town in the midst of Native American territory. While likely quite practical at the time to quickly identify the settlement in conversation, today this named seems, at best, not politically correct and, at worst, downright racist. In fact, in 2005, due to the intonations of the town name in our contemporary society, the town voted as to whether or not to change the name. The mayor and others noted that big companies such as Home Depot and Wal-Mart –which would bring jobs and industry to the community– were deterred due to the name's racial intonations today. Clearly, as the town name was in the atlas during the creation of *Postcards from chromatic places*, the town voted down the name change as they wanted to preserve the history of the hard working people who settled there.

Some European settlers named towns based on elements they saw nearby. Ironically, this naming convention arises for many people in Native American tribes (individuals that, in fact, the new settlers were trying to squelch). Native American names of individuals often derive from the first thing a mother sees after the birth i.e. Crazy Horse, Red Cloud (mentioned above), Sitting Bull, and other famous chiefs. In light of the unfortunate marginalization of Native American tribes by the European settlers who arrived to the Americas, it is noteworthy and eyebrow-raising that the towns of Red Cloud and White Shield were named after Indian chiefs.

The research uncovered other surprising geneses of town names, such as Toast, NC (possibly from a marketing name of a color of shoes in a nearby box) and Cocoa (perhaps inspired by the Baker's Cocoa-brand now-iconic tin package in which the postal service delivered mail). As, arguably, our society becomes more saturated with media and marketing influences, early precedents in this tradition lingering in our landscape prove particularly prescient.

## CONCLUSION

As this paper is first and foremost presentation of a design project, it provides findings organized into visual imagery with final output as a color chart and postcards. Here, text accompanies the design to offer a glimpse of reasons behind naming choices and to provoke further investigation. Some reasons found here mesmerize and warrant papers all to themselves. Of course, more facts could be uncovered with the play of linguistics and geography, and more research could be done in many other directions. For example, tracing the roots of settler names (from which town names based on people are derived) could prove enlightening as well as researching the names of the regions given by the indigenous population (a few of which inspired names above) before European settlers arrived. In summary, *Postcards from chromatic places* launches a voyage through colors of the American cultural landscape and explores color's linguistic presence in the geography of the everyday.

## ACKNOWLEDGEMENTS

Thank you to the Center for Excellence in Teaching at the Fashion Institute of Technology for providing a grant to support presentation of this project at the AIC 2019 conference in Buenos Aires.

**BIBLIOGRAPHY**

- About Cinnaminson. Cinnaminson township: Building our future ... together. Accessed July 31, 2019. [http://www.cinnaminsonnj.org/?page\\_id=23](http://www.cinnaminsonnj.org/?page_id=23).
- About Us. East Carbon City – Sunnyside, Columbia, Dragerton. Eastcarboncity.com. Accessed July 31, 2019. <https://eastcarboncity.com>.
- A history of Copperhill, Tennessee. Carolina Ocoee. Accessed July 31, 2019. <https://carolinaocoe.com/a-history-of-copperhill-tennessee/>.
- A. Warner and Company. 2008. *History of Allegheny County, Pennsylvania, including Its early settlement and progress to the present time*, vol. 2, part 1. Berwyn Heights, MD: Heritage Books.
- Barakat, Matthew. 1999. Town loses namesake when lime kiln destroyed. *The Frederick-News Post*, June 3, 1999. [https://www.fredericknewspost.com/archive/town-loses-namesake-when-lime-kiln-destroyed/article\\_57379d13-341c-5f6c-980e-dcdd1f4ced00.html](https://www.fredericknewspost.com/archive/town-loses-namesake-when-lime-kiln-destroyed/article_57379d13-341c-5f6c-980e-dcdd1f4ced00.html).
- Bently, Oresemus Hills. 1910. *History of Wichita and Sedgwick County, Kansas, past and present, including an account of the cities, towns and villages of the county*. Sedgwick County, KS: Windmill Publications.
- Blue Ash, Ohio: City of Blue Ash. History. Blue Ash – Aspire. Achieve. Advance. Accessed July 31, 2019. <http://www.blueash.com/government/history.php>.
- Bluewater. The Route66.com. Last modified May 22, 2019. <https://www.theroute-66.com/bluewater.html>.
- Boothe, Wayne. Dill City. *The encyclopedia of Oklahoma history and culture*. Accessed July 31, 2019. <https://www.okhistory.org/publications/enc/entry.php?entry=DI006>.
- Bowling Green, Ohio. *QuinStreet, Inc.* Accessed November 23, 2018. <https://www.citytowninfo.com/places/ohio/bowling-green>.
- Brosnahan, Tom. Ivoryton, Connecticut Guide. Newenglandtravelplanner.com Accessed July 29, 2019. [https://newenglandtravelplanner.com/go/ct/ct\\_river/essez/ivoryton.html](https://newenglandtravelplanner.com/go/ct/ct_river/essez/ivoryton.html).
- Caledonia County- Peacham. *North Star Weekly e-edition*, Sep 3, 2016. [http://www.northstarmonthly.com/kingdom\\_guide/town\\_profiles\\_history/peacham/article\\_3b451060-7200-11e6-87d8-d35421ae4f3d.html](http://www.northstarmonthly.com/kingdom_guide/town_profiles_history/peacham/article_3b451060-7200-11e6-87d8-d35421ae4f3d.html).
- Cannizaro, Steve. The name game: Local communities steeped in history, lore. *Times-Picayune/St. Bernard Picayune*, April, 17, 2005. [www.wikizeroo.net>Violet,\\_LA/](http://www.wikizeroo.net/Violet,_LA/).
- Cherryfield. DownEast Acadia – True Maine. Copyright DownEast Acadia Regional Tourism. Accessed July 31, 2019. <https://downeastacadia.com/story/cherryfield>.
- Chicago and North Western Railway Company. 1908. *A history of the origin of the place names connected with the Chicago & North Western and Chicago, St. Paul, Minneapolis & Omaha Railways*.
- Chinook Salmon (*Oncorhynchus tshawytscha*). Alaska Department of Fish and Game. Accessed July 31, 2019. <http://www.adfg.alaska.gov/index.cfm?adfg=chinook.printerfriendly>.
- Coffee Creek Montana. Central Montana. Accessed July 31, 2019. <http://centralmontana.com/communities/coffeecreel/htm>.
- Coolidge, Austin J., and John B. Mansfield. 1859. *A history and description of New England*. Boston, MA: Austin J. Coolidge.
- Coralville History. Coralville, Iowa. Coralville.org. Accessed July 31, 2019. <https://www.coralville.org/305/Coralville-History>.

- Donehoo, George P. 2019. *A history of the Indian villages and place names in Pennsylvania*. Pickle Partners Publishing.
- Federal Writers' Project. 1938/2018. *The WPA guide to Mississippi: The Magnolia State*. Atlanta, GA: Trinity Press.
- Federal Writers' Project. 1941. *Origin of place names: Nevada*. Works Progress Administration.
- Foy, Edna Riddle. Dill City. *Lauren's County sketchbook*. Accessed July 31, 2019. <https://www.okhistory.org/publications/enc/entry.php?entry=DI006>.
- Gannett, Henry. 1905. *The origin of certain place names in the United States*. Washington, DC: Government Printing Office.
- Georgia On My Mind. Blackshear. Georgia Department of Economic Development. Accessed November 23, 2018. <https://www.exploregeorgia.org/city/blackshear>.
- Golden, CO. *Golden history Museums*. Accessed July 31, 2019. [www.goldenhistory.org](http://www.goldenhistory.org).
- Goldsmith, Oliver. 1770. *The deserted village. A poem*. London. Available online: <https://www.poetryfoundation.org/poems/44292/the-deserted-village>.
- Grapevine History. Grapevine Convention & Visitor Bureau. Accessed July 29, 2019. <https://www.grapevinetexasusa.com/plan/history/>.
- Great Hill Cobalt Mines, Cobalt, East Hampton (Chatam), Middlesex Co., Connecticut, USA. Hudson Institute of Mineralogy. Accessed July 31, 2019. <https://www.mindat.org/loc-17109.html>.
- Gurlacz, Betsy. Evergreen Park, IL. *Encyclopedia of Chicago*. Accessed August 3, 2019. <http://www.encyclopedia.chicagohistory.org/pages/439.html>.
- Hillinger, Charles. 1985. Arkansas' towns of funny names: There's Evening Shade, Greasy Corner, Stump City, Hope. *Los Angeles Times*, October 13, 1985.
- History and Culture. CivicPlus. Accessed July 31, 2019. <https://www.cocoaf1.org/908/History-Culture>.
- History. City of Blue Hill. Accessed July 31, 2019. <https://www.bluehillne.com/history>.
- History. Concrete Chamber of Commerce. Accessed July 29, 2019. <https://concrete-w.com/history/>.
- History of Blackfoot, Idaho. U-S-History.com. Accessed July 31, 2019. <https://www.u-s-history.com/pages/h2583.html>.
- History of Orange City. Orange City – color your life vibrant. Accessed July 31, 2019. <https://www.octulipfestival.com/history-heritage/history-of-orange-city/>.
- History of Red Cloud. Red Cloud tourism and commerce. Accessed July 31, 2019. <https://www.visitredcloud.com/about/history-red-cloud>.
- History of Snowflake, AZ. Last modified October 21, 2000. [www.jerrystewart.org](http://www.jerrystewart.org).
- History of the town. The town of Pepperell. Accessed July 31, 2019. <https://www.town.pepperell.ma.us/131/History-of-the-Town>.
- History of White Plains. The City of White Plains. Accessed July 31, 2019. <https://www.cityofwhiteplains.com/469/History-of-White-Plains>.
- History. The Pimento School Project. Accessed July 31, 2019. <https://pimentocommunitycenter.wordpress.com/history/>.
- History. Town of Blacksburg, VA. Accessed August 11, 2019. <http://www.blacksburg.gov/community/community-profile/history>.
- How did Michigan cities get their names? Pure Michigan. Accessed August 3, 2019. <https://www.michigan.org/article/trip-idea/how-did-michigan-cities-get-their-names>.
- Jex\_Schexnaydre. Last modified September 19, 2003. <https://www.ancestry.com/boards/localities.northam.usa.states.louisiana.parishes.ascension/681.m.b.ash>.



- Katja. The little red houses you see everywhere. Swedish Language Blog, July 21, 2010.  
<https://blogs.transparent.com/swedish/the-little-red-houses-you-see-everywhere/>.
- Kaetz, James P. 2018. Red Level. *Encyclopedia of Alabama*. Auburn, AL: Alabama Humanities Foundation. Last modified September 16, 2016.  
<http://www.encyclopediaofalabama.org/article/h-3814>.
- Krakow, Kenneth K. 1975. *Georgia placenames: Their history and origins*. Macon, GA: Winship Press.
- Larsen, Erik. Wonder how your town got its name. App.com, part of the USA TODAY Network, May 6, 2016. <https://www.app.com/story/news/history/erik-larsen/2016/05/06/wonder-how-your-town-got-its-name-monmouth-county/82427814/>.
- Laurens County, SC, towns: How did they get their names? Geocities.ws. Accessed August 3, 2019.  
<http://www.geocities.ws/genebrooks/laurensconames.html>.
- Lemon Grove, CA, travel, photos information and news. California Cities. Accessed July 29, 2019.  
<http://www.seecalifornia.com/california-cities-lemon-grove.html>.
- Lilley, Jessica. Inside Appalachia. Audio Tape. Accessed July 31, 2019.  
[http://cpa.ds.npr.org/wvpn/audio/2015/01/IA\\_Jan\\_10\\_podcast.mp3?fbclid=IwAR1Pyo7JcbMoTT-LNXI66E7gFTyB2F9GR\\_2aLo4hjwZ1wUpdwVzMmnW3gNk](http://cpa.ds.npr.org/wvpn/audio/2015/01/IA_Jan_10_podcast.mp3?fbclid=IwAR1Pyo7JcbMoTT-LNXI66E7gFTyB2F9GR_2aLo4hjwZ1wUpdwVzMmnW3gNk)
- Lime. Ghosttowns.com. Accessed July 31, 2019. <https://www.ghosttowns.com/states/or/lime.html>.
- Milan, Brett. Silt: 100 years of rich history. *The Citizen Telegram*, August 1, 2015.  
<https://www.postindependent.com/rifle/silt-100-years-of-rich-history/>.
- Miller, Mike- Cocoa, Florida. Florida-Backroads-Travel.com. Accessed July 31, 2019.  
<https://www.florida-backroads-travel.com/cocoa-florida.html>.
- Morris, Michele. Voters to decide on name for White Settlement. NPR.com. Last modified November 7, 2005. <https://npr.org/templates/story/story.php?storyId=4993235>.
- New Hampshire Employment Security. Auburn, NH. ELMI Economic and Labor Market Information Bureau. Last modified December 2018. <https://www.nhes.nh.gov/elmi/products/cp/profiles-hm/auburn.htm>.
- Nilsson, Dex. 2005. *Why is it named that? Stories behind the names of 250 places in Madison County and Huntsville, Alabama*. Huntsville, Alabama: Twinbrook Communications. Accessed July 31, 2019.. <https://aic-color.org/page-18059>.
- Northumberland, New Hampshire. Wikipedia. Accessed July 31, 2019.  
[https://en.m.wikipedia.org/wiki/Northumberland,\\_New\\_Hampshire](https://en.m.wikipedia.org/wiki/Northumberland,_New_Hampshire).
- O'Dell, Larry. Pink. *The encyclopedia of Oklahoma history and culture*. Accessed November 23, 2018.  
[www.okhistory.org](http://www.okhistory.org).
- Orangeville. Accessed July 31, 2019.  
[http://www.emerycounty.com/archives/Archive\\_Photos/Orangeville/Orangeville.pdf](http://www.emerycounty.com/archives/Archive_Photos/Orangeville/Orangeville.pdf).
- Olive Branch History. Mississippi Chamber of Commerce. Accessed July 31, 2019.  
<http://olivebranchms.com/olive-branch-history/>.
- Parchment community history. Parchment Community Library. Accessed July 31, 2019.  
<https://www.parchmentlibrary.org/local-history>.
- Pearl City. Millie. Accessed July 31, 2019. <https://www.gomillie.com/neighborhoods/pearl-city/>.
- Pink, Oklahoma. *Wikipedia*. Accessed November 23, 2018.  
[https://en.wikipedia.org/wiki/Pink,\\_Oklahoma](https://en.wikipedia.org/wiki/Pink,_Oklahoma).
- Profile for Falun, Kansas, KS. ePodunk – the power of place. Accessed July 31, 2019.  
<http://www.epodunk.com/cgi-bin/genInfo.php?loclIndex=4626>.

- Red Hook History. Waterfront Museum. Accessed July 31, 2019. <http://waterfrontmuseum.org/red-hook-history>.
- Rennick, Robert M. 2013. *Kentucky place names*. Lexington, KY: University Press of Kentucky.
- Richardson, Russ. Butternut in West Virginia. Nativetreesociety.org. Last modified August 10, 2003. [http://www.nativetreesociety.org/species/sp\\_threads/butternut\\_in\\_west\\_virginia.htm](http://www.nativetreesociety.org/species/sp_threads/butternut_in_west_virginia.htm).
- Saltillo, Pennsylvania. Wikipedia. Accessed July 31, 2019. [https://en.wikipedia.org/wiki/Saltillo,\\_Pennsylvania](https://en.wikipedia.org/wiki/Saltillo,_Pennsylvania).
- Simmons, Suzanne. Down home in blue grass. *Cooperative Living*, March-April 2003. Accessed July 29, 2019. <https://www.co-opliving.com/coopliving/issues/2003/MarchApril/downhome.htm> pp 40-46.
- Strack, Don. Kaiser Coal Company. UtahRails.net. Accessed August 11, 2019. <http://utahrails.net/utahcoal/kaiser-coal.php>.
- Steinbrinck, Ashley. How 15 Wisconsin cities got their names. *WhooNew: Discover the Best of Northeast Wisconsin*, April 21, 2014. <http://whoonew.com/2014/04/how-15-wisconsin-cities-got-their-names/>.
- Teske, Steven. Zinc (Boone County). *Encyclopedia of Arkansas*. Last modified May 15, 2017. <https://encyclopediaofarkansas.net/entries/zinc-boone-county-6203/>.
- Town History. Welcome to Orange, Vermont. Accessed August 11, 2019. <https://orangevt.org/>.
- Weiser, Kathy. Gray Summit, Missouri – Meandering through the Ozarks. Legends of America. Last modified July 2019. <https://www.legendsofamerica.com/mo-graysummit/>.
- White Settlement residents vote down name change. *KXXII Fox News 12*, November 9, 2005. <https://www.kxii.com/home/headlines/1958852.html>.
- Wixey, Bill. How did Bremerton get its name? *Q13 Fox All Local*. Last modified June 13, 2018. <https://q13fox.com/2018/06/13/how-did-bremerton-get-its-name/>.
- Wyoming Big Sagebrush - Wyoming State Shrub. State Symbols USA. Accessed July 31, 2019. <https://statesymbolusa.org/symbol-official-item/wyoming/plants/wyoming-big-sagebrush>.
- Wyoming: Kelly. VisitTheUSA.com. Accessed July 29, 2019. <https://www.travelwyoming.com/cities/kelly->.

# Inherent and perceived colour: Bolivia-La Paz-Copacabana

Sara Leonor Kenny\*, María Inés Girelli

Universidad Nacional de Córdoba, Facultad de Arquitectura, Urbanismo y Diseño,  
Instituto del Color, Córdoba, Argentina

\* sara@sarakenny.com.ar

## ABSTRACT

This work develops the didactic experience and the conclusions produced in a student trip made within the framework of an academic agreement with the Faculty of Architecture, Arts, Design and Urbanism of the Universidad Mayor de San Andrés, La Paz, Bolivia, and the Faculty of Architecture, Urban Planning and Design of the National University of Córdoba, Argentina. During it, surveys were carried out of urban spaces and natural spaces, from perception as from the inherent color. The inherent color survey was done using the NCS (Natural Color System) ColorPin device. Throughout this process the students were able to get to an experimentation of the management and creation of color, as well as to understand the environmental or texture variables that affect and transform it.

**Keywords:** *perception, inherent color, color teaching*

## DEVELOPMENT

This work develops the didactic experience and conclusions produced in the student trip carried out within the framework of an academic reciprocity agreement with the Faculty of Architecture, Arts, Design and Urbanism of the Universidad Mayor de San Andrés, La Paz, Bolivia, and the Faculty of Architecture, Urban Planning and Design of the National University of Córdoba, Argentina. The organizing teachers are members of the chair of Morphology III (Urban Morphology) of the FAUD-UNC and the Institute of Color FAUD-UNC. The workshop was called “Chromatic Itineraries. Actions in the Latin American Public Space”.

From our role, we constantly ask ourselves about what tools we should give our students, so that they are not only professionals, but also human beings committed to the city and society. Our particular interest was born on the one hand in order to carry out a practice, starting as a central theme to color, this is a component of the programmatic contents of the Morphology III subject, articulating them with the emerging studies of the research projects developed in the framework of the Color Institute. Also, transfer to this practice the chromatic revaluation experiences specified by

this team in the public space of our city and province. In addition, we should raise awareness about the value of color in the public space, understanding it as a participant inherent in the sense that it acquires as a framework for social life, of events, of exchanges between actors who intervene and appropriate places from their use and significance, depending on the culture of your group of belonging.

The color developed as essential information is a real vehicle that facilitates the end and significance of the urban experience and is decisive for the construction of cognitive maps, as representations of the itineraries experienced by the inhabitant. Color acts as an action tool that allows you to communicate and identify with the environment you inhabit, contributing to a clearly readable and experientially identifiable urban landscape.

The exchange between teachers and students allowed to share and carry out joint participation actions to enhance academic developments aimed at strengthening the integral training of the participants. The meeting was attended by 18 students from our chair, which were integrated to a greater number of students from La Paz, participating and linking for 4 days of the proposed activities. Also, to the organizing teaching team, we were also joined by teachers from that house of studies, who in addition to participating, presented their work and theoretical content that has been developing.

During the trip, surveys were carried out of urban spaces and natural spaces, both from perception and from the inherent color. The aim was to understand the inherent color as the material's own color, which can be measured in an atmosphere without alteration of lights, shadows, environment, etc.

The inherent color survey was done using the NCS (Natural Color System) ColorPin device. This device works by reading the color on different materials or objects, and then sends the exact information to the mobile device via bluetooth. This generates a summary form of all the reading in the previously assigned site.

The determination of the perceived color, which is also given in NCS notation, was based on the visual comparison with the samples of the NCS. The observation is made by comparing the color observed in a certain wall with the color in the NCS atlas, using the color circle and triangles according to each chroma, determining the NCS notations. This method assumes that the observers know the management of the NCS atlas and understand its variables, to be able to recognize which of the NCS samples is the one that most closely resembles the color perceived.

The numerical values of the perceived color provided by the NCS allow computing the different color attributes. This technique is developed in class, and is based on the research of several members of the Color Institute, explained in the book by Ávila and Polo (1996). Connecting with these concepts, and making these readings, makes the student more sensitive to the subject, arouses their interest and encourages personal searches in this regard.

After the field work, we went back to the workshops and worked with pigments to reproduce the observed colors, to understand their composition from the same color theory and finally measure them in the inherent values.

Throughout this process, students were able to experiment with the management and creation of color, as well as understand the environmental or texture variables that affect and transform it. It is from this base that the students were able to propose interventions and urban landscape modifications, within a learning process that faced them with the challenge of having a more inquisitive and creative attitude to apply knowledge acquired in the subject and motivate the continuation of the formation.



## CONCLUSIONS

This experience becomes of great value because of the added bonus that the experience of traveling and interacting with other cultures can give. Not only does it build a better teacher-student relationship, but also stimulates the development of friendly ties with other colleagues, who work on the same subject from other cultural perspectives. Knowing other customs and ways of life enriches the spirit and strengthens us from the Latin American identity that identifies us.

In 2019, we returned to replicate this experience, with a greater number of students, and bound for Potosi-Sucre-Uyuni. The work point was in the city of Sucre, in addition to the Faculty of Architecture of La Paz, and the Faculty of Architecture of Oruro.

We have the permanent support of a whole team of professors, and a large number of students from all participating institutions. In this way an international color network is consolidated, with a strong Latin American accent.

Color is the common element that unites us and mobilizes us to continue. It implies a great teaching effort, but brings us great satisfaction, knowing that we guarantee identity roots in our students, on the way to building better spaces and cities.

## REFERENCE

Ávila, M. M., and M. R. Polo. 1996. *Color urbano: indagaciones en ámbitos de la ciudad de Córdoba*. Córdoba, Argentina: Eudecor.

# Lisbon: the colour of change

Cristina Caramelo Gomes<sup>a\*</sup>, Catarina Diz de Almeida<sup>b</sup>, José Afonso<sup>b</sup>

<sup>a</sup> Universidade Lusíada, Faculdade de Arquitectura e Artes, Lisbon, Portugal

<sup>b</sup> Universidade de Lisboa, Faculdade de Arquitectura, Lisbon, Portugal

\* cris\_caramelo@netcabo.pt

## ABSTRACT

Urban space is changing dramatically due to gentrification process and the will to make better places based on the opportunities promoted by the development and implementation of Information and Communication Technologies. The emergence of the smart urban concept aims to contribute to a more sustainable environment with a strong impact in the way we live and interact. Despite the determinant performance of technology, a new emphasis is given to quality of life with a user centric approach. This model intends to return the urban space to the user, promoting spaces that motivate their enjoyment through the interactions developed between users and between them and the built environment. In these interactions with the physical space which is the assignment of colour? How does colour contribute to the qualification of the urban space as well as the quality of its enjoyment by the user? The aim of this paper is to understand how colour can be an indisputable component of smart solutions within the development of urban design in Lisbon.

**Keywords:** *colour, urban design, smart solutions, user experience, Lisbon*

## INTRODUCTION

Lisbon urban design is changing, driven by smart solutions which aim to humanise built environment offering equipment and services, enhancing people appropriation of the urban space.

While Lisbon is growing as a smart place, people realise that the smart concept is more than environmental and economic oriented solutions revealing a strong social impact, in changing the way people live and interact with public places. However, does this contemporaneous urban space offer a humanised solution? Does it stimulate human senses towards the nurture of the emotion? At the end, are we still in an industrial image, with a technical focus or, are we producing humanised environments where human senses are stimulated and colour, in their dissimilar dimensions, assumes a leading role?

Such solutions contribute to a positive user experience; however, the human sense of comfort and wellbeing in the use of urban environment goes beyond technical solutions. Users demand more than an environment responsive to functional needs, users demand emotional stimulus.

Colour in built environment emerge as a tool of language, expression, communication and assembly encouraging users' stimulus, emotions and behaviour. More than desirable, urban spaces approach colour in its aesthetical dimension plus its influence on urban area identity mainly by the reproduction of patterns sustained by traditional materials, construction process and colour, disregarding the functional and emotional power of colours and how these attributes can contribute to model human behaviour. In a moment where the concept of smart cities invades important metropolitan areas, providing technical solutions that benefit built environment with new equipment and services, where the exterior space emerges as a scenario to improve human interactions how should colour be approaching to humanise built environment? How can colour be part of urban design smart solutions to enhance the social impact of smart concept?

To explore this subject, we will consider the city of Lisbon. Lisbon city centre becomes a preferential scenario to implement smart solutions. Yet, the available solutions illustrate their environmental and economic benefits neglecting their power to promote new ways of living and interacting with urban design. Considering the different levels to understand colour in built environment —the neighbourhood, the street, the building and the detail— and the functions that colour can assume in it, it is urgent to rethink the planning of urban chromatic palettes.

## **MAKING PLACES**

“It's hard to design a space that will not attract people. What is remarkable is how often this has been accomplished” (William White, in PPS 2016: 12).

A city can be characterised as an urban area where people live, work and interact. Cities can also be characterised as hubs of government, commerce and transportation. A city can be defined according to an administrative boundary which can be described by the extent of the contiguous urban area to outline the city's boundary or in a metropolitan area concept, due to the degree of economic and social interconnectedness of areas recognised by interlinked commerce or commuting patterns.

In 2018 more than 50% of the world's population inhabited urban areas. It is estimated that by 2030, these urban areas welcome 60% of global population. The challenges addressed by this phenomenon demands the acceptance and accomplishment of the 2030 Agenda for Sustainable Development to make urban environments inclusive, safe, resilient and sustainable (UN 2018).

Although the strength of the previous statements, urban environment appears as an abstract entity, where its functional performance and economic success overcome the place identity and the experiences that the place can offers to individuals enhancing the individual/community sense of belonging and quality of life. In search of this idea, some municipalities are changing their urbanistic goals, planning and implementing solutions oriented to sustainable and inclusive principles to attract people and offer new experiences while shaping the individual's desire to stay/return. The enhancement of the urban design is focused on the creation of innovative forms of use inspired by physical, cultural and social identities that build up a place and illustrates its unending evolution (PPS 2016). To achieve such promising intents the advances in technology must be considered; thus, understood, tested and implemented. Information and Communication Technologies (ICT) development emerge as an important assistant to improve a more sustainable and inclusive environment boosting a responsive urban environment to people needs and expectations.

## SMART URBAN ENVIRONMENTS

Literature review presents some inconsistency in the definition of the concept of smart urban environments. For a time, the emphasis was given to technology once there was the spread of ICT and its intrusion in our living and work patterns. Particular attention to ICT impact in our forms of communication and interaction. The last decade has witnessed the reorientation of the smart concept for the improvement of quality of life (Albino et al. 2015). Therefore, we select the definition of Thuzar (2011) to support the intends of this piece of research:

Smart cities of the future will need sustainable urban development policies where all residents, including the poor, can live well and the attraction of the towns and cities is preserved. [...] Smart cities are cities that have a high quality of life; those that pursue sustainable economic development through investments in human and social capital, and traditional and modern communications infrastructure (transport and information communication technology); and manage natural resources through participatory policies. Smart cities should also be sustainable, converging economic, social, and environmental goals. (Thuzar 2011, in Albino et al. 2015: 6)

Thus, the main objective of a smart city is to develop the quality of living for its citizens through smart technology.

Collinson and Quamar (2017) appoint six smart components to smart cities: “smart economy; smart people; smart governance; smart mobility; smart environment; and smart living”. A city to be smart requires a holistic interaction, interconnection and interdependence of the components. A smart city emerges as a place “connected, intelligent, innovative and adaptative”, which means a place where smart individuals conceive smart solutions to their urban daily life problems.

Users are the leading personages of a smart urban environment modelling it all over continuous interactions. A user-centred approach plus new ways of living encouraged by ICT, reveal the label of creativity associated with smart urban environment. This association emerges from the education, learning and knowledge encouraged by new ways of living and interacting thus promoting people connections and relationships (Alawadhi et al. 2012). As Winters points out (2011), smart people create and gain from the social capital of the city, so the smart city concept attains new interpretation of a mix of education/training, culture/arts, and business/commerce with blended social, cultural, and economic enterprises.

## USER EXPERIENCE TO USER EMOTIONAL EXPERIENCE

While experiencing urban environment, users can interact with the physical world as well as the digital one. Considering smart urban environments as the scenario, users experience the physical environment throughout different performances:

- walking around... streets, squares, blocks, neighbourhoods
- performing a function
- socialising with others in squares, terraces, seafront, etc.
- commuting from places and functions, benefiting from equipment and functionalities that allow to develop the duty with less effort in less time

Contemporaneous urban environment offers experiences to the users based on its physical and digital features. Physical experience can be identified by the way the layout, materials and



equipment available can contribute for the pleasure of enjoying built environment and a mix of physical and digital experience can be achieved by the use of new forms of mobility from the shared cars and the electric scooters that requires digital interactions to access and manage the experience. User interaction that defines the experience is so important in the physical level as the digital one. User evaluation of the experience depends how urban environment (considering its physical and digital features) responds to user needs and expectations.

User experience can be defined as the value of the experience that a user has when interacting with a designed scenario. User experience highlights the practical, emotional, meaningful and valued features of interaction design as well as user's perception of the everyday aspects such as utility, ease of use and efficiency of a system. User experience is lively once changes over time and related settings.

Urban environment is not excluded from the evaluation of the user's experience. The design of urban environment, despite its smart or "*dumb*" character, encourage and discourage user experience and the encouragement hangs on the emotion that the experience produces on the user. An emotional user experience is pleasing to human emotions to form the experience. Hence, it is important to highlight the key principles that support an emotion: stimulus, sensations and perception. The stimulus arises when a sensorial sense is tackled. The sensation refers to the abstract representation formed in the brain after the stimulus, such as sound, visual images, odour, taste, pain, etc... When all sensations are interpreted by the brain, it creates the individual perception of reality and consequently the experience evaluation.

## **COLOUR CONTRIBUTE TO IMPROVE USER EXPERIENCES AND EMPOWER THE SMART URBAN ENVIRONMENT**

Literature review states that colour acts in a physiological, psychological, biologic and aesthetic levels inducing authenticity, mood, creativity and productivity and change the use of a space. Urban settings are energized by colour, while the form of a city is modelled by the conceptual order drawn by buildings and spaces where colour shapes human perceptual experience (Torabi et al. 2012).

Urban environment impacts human psychological needs on human sense of belonging and beauty boosting the feelings of security, comfort, pleasure and satisfaction. Colours in urban environment have different functions from which emerge the conceptualisation of place's identity as well as the creation of an enchanting image that enriches user experiences.

Decoding the functions of colour in urban environment, allows to identify how they can influence its image and interpretation by the user. Colour designs user perception at information and emotional levels, unveiling surroundings and encouraging feelings that adjusts user's behaviour. Although the impact of colour in user, the colour that characterize and give identity to the city is the choice of a community that repeatedly by (no)choice use the same colour palette. Colour guides human sight to the shapes that worth attention while smoothing the integration of the human intervention in urban setting. When colour confers identity to the place contributes significantly to its beautification acting as well as an aesthetical and decorative element, discriminating different materials, forms, volumes and meanings granted by a symbolic and metaphoric language (Bahraini 2003).

Spaces in their sequences draw the urban environment network while colour unveils singularity within the unity. Inasmuch as the image of the city is not read by the user as a long shot the colour

reading depends, also, from its properties of hue, chroma and lightness as well as the observing distance and angle, ambient light and existence of colours in the different levels of background surroundings (Elliot 2015). City reveals the colour as the colour tailor city's identity (Doherty 2010). This complex composition manages the user experience of the place, defining usage patterns and establishing user's stimulus, emotions and behaviours.

Emotional feedback (and sequent human behaviours) to urban spaces' colour palette is many-sided and difficult to evaluate. However, the positive emotions can be delivered by the sense of belonging, harmony of natural and designed features and balanced sensorial stimulation, boosting the emotional blend among urban spaces and users (McLellan and Guaralda 2014). This leads to the engagement with the place and the will to experience it in a continuous form.

Colour existence in urban spaces, induces the appropriation of the space, with an operative, meaning and symbolic function shaping the experience of the place by the user despite his performance as an inhabitant, worker or visitant. Colour works as a natural GPS (global position system) technology identifying the place and heading directions and attention to details. Moreover, the use of polychromatic environments designs urban space vitality via creative solutions which influence and are influenced by human daily living. The appropriation of the urban space by users over time defines its identity and colour acknowledges it by being responsive to user needs and expectations.

## **LISBON AS A SCENARIO AND FURTHER DISCUSSION**

A popular and romantic legend states that Lisbon, as a city, was founded by the mythical Ulysses. Over time, dissimilar cultures have appropriated the city allowing their cultural landmark to prevail to this day, from which, Arab influence remains until today in the organic urban fabric, where narrow streets to escape from the sun are engraved by buildings revealing tiles with polychromatic geometric patterns sheltering new ways of living and dwelling. Globalisation and the technical progress lead to contemporaneous architecture with a new formal language where new materials emerge. Still the use of tiles is remains in conscious rehabilitation and new construction examples. The city has a marked personality, where colour and the characteristic light of Lisbon emerge as a label of authenticity.

Currently Lisbon is one of the six major European smart cities engaged in the Sharing Cities Project, with the purpose to gather strengths to the use of ICT to improve individuals' quality of life (Sharing Cities 2016). Lisbon's goal is to attract more people to the city by increasing energy efficiency housing, e-mobility, smart living and smart ageing solutions. Attention to social cohesion and inclusion via agendas for civic participation, rehabilitation of urban space and the optimization and interconnection of urban services and systems. Moreover, Lisbon was awarded with The European Green Award 2020, a city with 550,000 inhabitants and nearly 40,000 daily commuters (Smart Cities Brussels 2018).

While smart and sustainable urban services (based on real-time information collection and sharing) are better understood by the individuals familiar with technical skills and devices, even though its positive impact on the daily living of individuals, the solutions implemented on urban space to ageing and accessibility inclusion and a better enjoyment of the city are the ones that show major contribution namely for the physical (and digital) interactions and a qualified user experience. Built environment solutions demonstrate the willingness to return urban space to people.

The rehabilitation of the built environment substantially improved the image of the city which, associated with artistic events and leisure activities, boosted new and more qualified user's experiences. The tourism' boom led to a conscientious rehabilitation to fulfil comfort requirements while ensuring the authenticity of the place. Buildings and urban equipment show a polychromatic palette (detaching the city by trends and author projects) where the monochromatic tiles stamp their presence. Lisbon, a city where municipality does not have any methodology or regulation to colour application in urban environment is changing the attitudes of the last decades bringing the colour as a tool to offer a flavour of the city heritage; to attract user attention to particular features such as artistic graffiti from important artists with a clear social / political message, or to define leisure pathways where the colour of natural environment mingles with the built one, offering astonishing perspectives, permanence places where people interact physically and digitally, stimulating human senses and pleasing the experience and giving the sense of community. This sense of community encourages the engagement of citizens to commit with spatial layout turn it place with a profound appreciation of (im)material. Hollands (2008) points out that IT by itself cannot enhance urban environments. Therefore, social elements such as human capital must require a protagonist role in the process to ensure the creation of (smart) civic inclusiveness. Smartness is participation, engagement and how it shapes users' behaviours towards built environment.

Lisbon is a smart city beyond technology showing all the chromatic ingredients and compositions required by a smart city of which, stands out the user at the centre of the concerns and solutions regardless of their technological development or user technical literacy.

## ACKNOWLEDGEMENT

This work is financed by national funds by FCT - Foundation for Science and Technology, under the Project UID/AUR/04026/2019

## REFERENCES

- Alawadhi, S., et al. 2012. Building understanding of smart city initiatives. In: *Electronic Government. EGOV 2012. Lecture Notes in Computer Science*, vol. 7443, H. J. Scholl, M. Janssen, M. A. Wimmer, C. E. Moe, and L. S. Flak, eds. Berlin: Springer, 40-53.
- Albino, V., U. Berardi, and R. M. Dangelico. 2015. Smart cities: Definitions, dimensions, performance, and initiatives. *Journal of Urban Technology* 22 (1): 3-21.
- Bahraini, S. H. 2003. *Urban design process*, 2nd ed. Tehran: Tehran University Publications (in Persian).
- Collinson, S., and A. Qamar. 2017. Smart cities. In: *City-REDI - Policy Briefing Series*, October 2017. Online: <https://www.birmingham.ac.uk/Documents/college-social-sciences/business/research/city-redi/Policy-Briefings/policy-briefing-series-smart-series.pdf>.
- Doherty, G., ed. 2010. *Urbanism of colour*. Cambridge, MA: Harvard University Press.
- Elliot, A. J. 2015. Color and psychological functioning: a review of theoretical and empirical work. *Frontiers in Psychology* 6: 368.
- Hollands, R. G. 2008. Will the real smart city please stand up? *City* 12 (3): 303-320.

- McLellan, G., and M. Guaralda. 2014. Environmental colour and well-being. In: *Past Present and Future of Public Space, International Conference on Art, Architecture and Urban Design*, L. Bravo, ed. Online: <http://docplayer.net/58877373-Environmental-colour-and-well-being.html>.
- PPS (Project for Public Spaces). 2016. Placemaking - What if we built our cities around places? Online: <https://www.pps.org/article/what-is-placemaking>.
- Sharing Cities. 2016. *Building smart cities together - Common solutions for shared challenges*. Online. <http://www.sharingcities.eu/sharingcities/smartcities>.
- Smart Cities Brussels. 2018. *Smart city Lisbon*. Online: <https://smartcity.brussels/news-598-smart-city-lisbon>.
- Torabi, M., et al. 2012. *The functions of color in urban setting*. Online: [https://www.academia.edu/1487495/the\\_functions\\_of\\_color\\_in\\_urban\\_setting](https://www.academia.edu/1487495/the_functions_of_color_in_urban_setting).
- UN (United Nations). 2018. *The world's cities in 2018*. Online: <https://www.un.org>.
- Winters, J. V. 2011. Why are smart cities growing? Who moves and who stays. *Journal of Regional Science* 51 (2): 253-270.

# Making color palettes for multi-unit apartment buildings based on the building color survey in Japan, Portugal, and The Netherlands

**Kiwamu Maki**

Jissen Women's University, Japan  
maki-kiwamu@jissen.ac.jp

## ABSTRACT

The purpose of this study is to check the efficiency of the color palette —a series of color usage— instead of color limitation to apartment buildings. Thirty color palettes derived from color surveys for the multi-unit apartment building surfaces in three countries were used to make color simulated apartment building images. In the experiment, a total of 180 apartment building images were projected on-screen and evaluated using four semantic scales by female university students. The saturation of used colors seems to have large correlations to the building image preferences, low saturated color combinations were preferred than the others. The interaction between buildings and color patterns for the preferences were observed when the middle or high saturated colors were used for either remarkable or unremarkable parts of buildings.

**Keywords:** *color palette, multi-unit apartment, townscape, color control, preference*

## INTRODUCTION

It is rare to be said that Japan's townscape colors have been better even though the guidelines for townscape generally include color usage limits, primarily the color's chroma. The purpose of this study is to check the efficiency of the color palette —a series of color usage— instead of color limitation in case of coloring to the apartment buildings as an example.

## COLOR SURVEY OF THE APARTMENT BUILDINGS

### 1) Method

Color surveys for the multi-unit apartment building surfaces were conducted to make various color palettes. Surveyed 55 apartment building surfaces in three countries, including Japan, Portugal, and the Netherlands were selected by the researcher who felt the availability to be suitable for Japanese

buildings even though in the case they are rare to be observed in Japan. The three attributes of colors, Munsell hue, value, and chroma, of the main parts of building façades, were measured (see Figure 1). Table 1 contains the result of thirty buildings, ten in each country.



Figure 1: An example of surface color measurement results of an apartment building in the color survey.

## 2) Result

The contribution of three values of color suggests the YR to Y low saturated colors dominated at the surveyed areas in Japan. The YR to Y high brightness / low saturated color dominated in Portugal, whereas the YR and Y, B, PB color high brightness / low saturated, and low brightness / low saturated color dominated in the Netherlands (Figure 2, Table 1).



Figure 2: The examples of the building surface color palette derived from the survey in three countries.

Country	Sign	Color <1>	Color <2>	Color <3>	Color <4>	Color <5>	Color <6>
J a p a n	Ja_01	2.5Y 8/1	10B 5/1	5PB 3/1	N9		
	Ja_02	7.5YR 8/4	5YR 7/4	5Y 9/2			
	Ja_03	5BG 7/2	10GY 7/2	5BG 7/3	2.5YR 8/4	10YR 6/4	7.5YR 6/6
	Ja_04	2.5Y 7/6	2.5Y 7/3	N7	10YR 4/1		
	Ja_05	7.5YR 6/3	N9	5YR 6/8	10YR 4/3		
	Ja_06	N6	N9	5YR 5/1	10Y 9/1	10YR 5/3	2.5Y 7/3
	Ja_07	7.5YR 8/1	7.5R 2/6	7.5R 5/4	7.5YR 6/4	10YR 8/3	N9
	Ja_08	N9	5Y 9/6	5PB 3/8	N6		
	Ja_09	10RP 6/2	5PB 8/2	10Y 9/2	N 9		
	Ja_10	2.5Y 9/4	5Y 9/2	2.5Y 9/3	10R 5/6	2.5Y 9/2	
P o r t u g a l	Po_01	7.5R 8.5/3	2.5Y 9/1	2.5Y 8.5/1			
	Po_02	7.5R 9/2	10Y 9.5/1	10R 3/6	N8		
	Po_03	2.5Y 9.5/1	10R 4.5/8	10YR 9/1	5G 2/4		
	Po_04	10R 8/4	5R 2/6	10YR 7.5/4	10R 6/4		
	Po_05	10GY 8/4	7.5R 8/4	5B 8/2	5YR 8/6	10Y 9/1	2.5YR 5.5/12
	Po_06	10G 8.5/1	2.5YR 9/2	2.5Y 8.5/1.5			
	Po_07	5PB 9/1	2.5Y 9/3	10B 6/3			
	Po_08	10Y 9/1	7.5Y 9/6	5RP 8/6			
	Po_09	10YR 7/8	N7.5	7.5YR 8/3	2.5YR 8/6	2.5Y 6.5/1	
	Po_10	2.5YR 4/8	5Y 7/4				
N e i t h e r l a n d	Ho_01	10G 2/4	N9	2.5Y 9/3	5YR 4/6		
	Ho_02	10G 7/2	5Y 9/6	2.5YR 2/2			
	Ho_03	N4	2.5YR 2.5/4	2.5YR 2/1			
	Ho_04	10R 5/8	2.5YR 5/10	7.5R 3/8	10YR 8.5/3		
	Ho_05	7.5YR 4/6	2.5Y 8/3	10B 3/1			
	Ho_06	10YR 7,5/2	5Y 8/2	7.5R 3/2	N 2		
	Ho_07	5YR 3/1	5YR 3.5/6	10R 3.5/3	5Y 8/14	N 2	
	Ho_08	5G 2/6	10B 3/4	2.5Y 3/4	7.5R 4/12	5R 3/12	10Y 5/1
	Ho_09	5G 8/1	10B 2/3	N9	5B 3/1	7,5R 3/3	5Y 8/6
	Ho_10	N 6	N 8	7.5Y 9/7	10BG 5/2	2.5YR 7/10	

Table 1: The result of the building surface color survey in three countries.

(This table does not show the distribution of typical colors of apartment buildings in the countries, but it shows the colors of measured buildings and used as color palettes.)

## EVALUATION OF COLOR-SIMULATED APARTMENT BUILDING IMAGES

### 1) Method

A total of 180 apartment building images were projected on-screen and evaluated using four semantic scales by female university students aged twenty to twenty-two. Thirty images were taken at the survey. The 150 color-simulated images were derived from a combination of five buildings (Figure 3) and thirty color palettes that picked up colors from the original thirty buildings. Simulated colors were adjusted to the RGB values of color chips that have aimed hue, value, chroma values on the image of the sheet of the *Book of Japanese Industry Standard Color Standards* which were taken

on a cloudy day to match the same lighting condition as the building images. As a result, the color on the images must be the same in the photos of the real building.



Figure 3: The original apartment buildings for color-simulated images.

## 2) Result

Three of the four scales showed that preference, calmness, and remarkableness have a high correlation, over 0.8 in absolute value (Figure 4). This means preferable apartment buildings have calm and unremarkable colors.

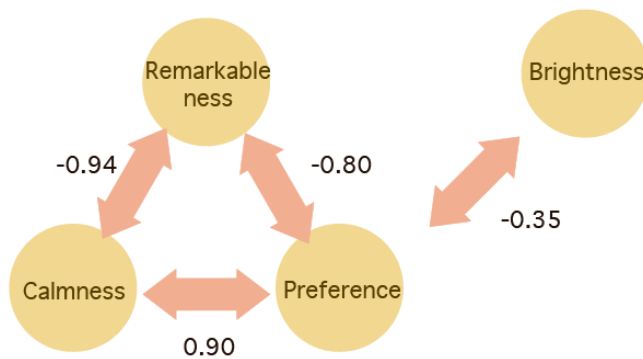

Figure 4: The correlations among the evaluated four SD scales.

Figure 5 shows the preferences of the evaluated 180 apartment building images from low value to high value on the color patterns sorted by the countries. The center of Figure 5 shows the preferences of the building images whose color patterns derived from the survey in Portugal have similar tendencies (gradient) among five buildings. The right part of Figure 5, the color patterns of apartment buildings from the Netherlands, also show similar tendencies except some of “townhouses” and the “developer’s apartments.” In the left part of Figure 5 which indicate the images of Japanese apartment building color patterns, the preference evaluation tendencies of “condominium”, “housing complex”, “low-rise apartment” show similar tendencies, gradually rise left to right.

In these tendencies, the saturation of used colors seems to have large correlations to the building image preferences. The images using only high brightness / low saturated colors and only high and low brightness / low saturated colors were relatively preferred over other images containing middle or high-saturated colors. The border of saturation to be preferred is roughly less than four on Munsell chroma.



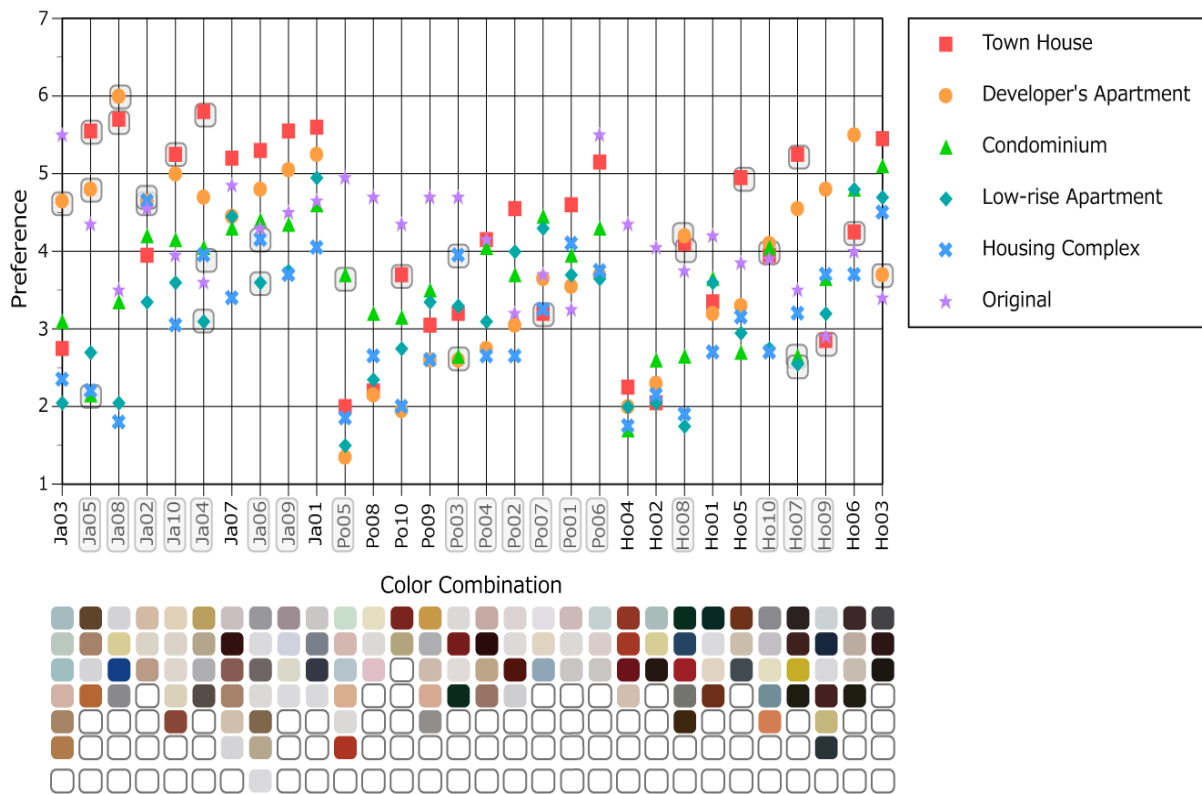

Figure 5: The preferences of the evaluated 180 apartment building images (original thirty buildings and the combinations of five apartment buildings by thirty color patterns).

Some of townhouses and developer's apartments show different values from the average tendencies in Japanese color patterns. The corner-rounded gray rectangles on the marks in Figure 5 indicate such samples that show large differences from the average tendencies. These interactions between buildings and color patterns were observed mainly when the middle or high saturated colors were used for either remarkable or unremarkable parts of buildings. It's the main reason that the interactions were observed at relatively less preferred color patterns mainly.

However, it couldn't explain that most of the interaction observed samples concentrated to "townhouses" and " developer's apartments," and the higher scores of some original buildings in addition. It seems to relate to the composition of the colored field. The setting of three types of composition would be useful to explain this matter.

The first type such as "Housing complex," "condominium" and "low-rise apartment" contains line shape elements. These are the typical composition in Japanese apartment buildings. In these cases, the preferences show the tendencies that they reflect the color pattern effect directly. The second type is "figure and ground," typically observed at "townhouse," have a large wall and small plate shape parts in it. The third one is a row of the colored plates typically observed at the apartments in Europe. "Developer's apartment" is an variation of this type, a composition of relatively large size plates or walls without a background wall. The latter two types of apartments show the availability to permit the use of various colors.

## DISCUSSION

The guidelines in Japan are set at less than or equal to four to the Munsell chroma limitations. It could be said useful after the results of this experiment.

The availability to replace color usage limitation to color palettes is still unclear depending on the results of the experiment. However, the usage of remarkable color in large areas and the composition of building façades would have a high potential to explain the interaction between buildings and color patterns. The three types of palettes based on the colored area combination of buildings have availability to make urban color control effective.

## ACKNOWLEDGEMENTS

The author tremendously appreciates to Sakura Iijima and Arisa Watanabe for their assistance to conduct the experiment. The color survey to Portugal and the Netherlands was supported by JSPS KAKENHI Grant Number JP23611003.

## REFERENCE

Maki, K., et al. 2014. Color control influence on streetscape color simulation in which colors are selected by subjects - For wall color transition and the evaluation of the result. *Transactions of AIJ. Journal of Environmental Engineering* 79 (706): 1009-1015 (in Japanese).

# A case study on environmental landscape color harmony via the Zhengbin Fishing Port color scheme

Yen-Ching Tseng<sup>a\*</sup>, Yuh-Chang Wei<sup>b\*</sup>, Monica Kuo<sup>c</sup>, Ya-Ping Kuo<sup>c</sup>, Wen-Guey Kuo<sup>d</sup>

<sup>a</sup> Department of Architecture and Urban Design, Chinese Culture University, Taipei

<sup>b</sup> Department of Information Communications, Chinese Culture University, Taipei

<sup>c</sup> Department of Landscape Architecture, Chinese Culture University, Taipei

<sup>d</sup> Department of Textile Engineering, Chinese Culture University, Taipei

\* yenching.tseng@gmail.com, ycwei@faculty.pccu.edu.tw

## ABSTRACT

The purpose of the study is to analyze the significance of environmental landscape color harmony via the Zhengbin Fishing Port Color Scheme. A multi-color combinations façade of the seafront architecture complex is the target color scheme. A scientific NCS environmental color survey conducted to collect regional colors information and to establish an environmental color database. A subjective environmental color analysis evaluated by the color planner to develop a color planning strategy. Based on the principle of color harmony, the color planner designed a multi-color combinations scheme by selecting domain colors and increasing color contrast in compliance with proper lightness, chroma, environment context, and color composition to fulfill the project's objectives. The overall performance of the color scheme perceived quite harmonious with environmental landscape colors. Indeed, it was not only to enhance the Zhengbin Fishing Port's regional characteristics and cultural style successfully, but also to become a visual landmark as well.

**Keywords:** *environmental landscape color, color harmony, color scheme, NCS environmental color survey tool, subjective environmental color analysis*

## INTRODUCTION

The concepts of environmental landscape color harmony are highly dependent on nurture and culture. The current study used the color scheme project, funded by city government, of the nostalgic pier of Zhengbin Fishing Port located at Keelung city in northern Taiwan, as an example. The color project team was led by the architect. The color scheme is, based on Jean-Philippe Lenclos's methodology of color geography, to adopt NCS environmental color survey tool for the regional local colors investigation and to develop a color planning strategy. The objective of color planning strategy is to maintain the balance between the color imagery of harbor city and Zhengbin Fishing Port area, to achieve "colorful diversity", and to develop a proper color scheme to enhance

regional characteristics and cultural style of the Zhengbin Fishing Port. The aim of this study is to reveal the significance of color harmony scheme to create a visual landmark on local environmental landscape by renovating a new multi-color combinations façade of the seafront architecture complex (Figure 1).



Figure 1: The color façade (a rectangular area) of seafront architecture complex is the target color scheme (left). Geographical location of Zhengbin Fishing Port, located at Keelung city in northern Taiwan.

## METHODS

### NCS environmental color survey and data analysis

Natural Color System, NCS (Hård, Sivik and Tonnquist 1996), is represented based on the perceptions of human vision, and the color combination can be classified according to chromatograms. NCS environmental color survey tool was used to collect and analyze the environmental landscape colors around the natural geographical region. The environmental color analysis was through a systematic process using photography, color patch mapping, color measurement, sampling, coding, and summarization. A color database with 269 color patches categorizes into the domain color, secondary color and embellishment from the Zhengbin Fishing Port environmental landscape. A histogram color chart (Figure 2) was drawn to show the distributions of collected regional color samples via NCS five color categories.

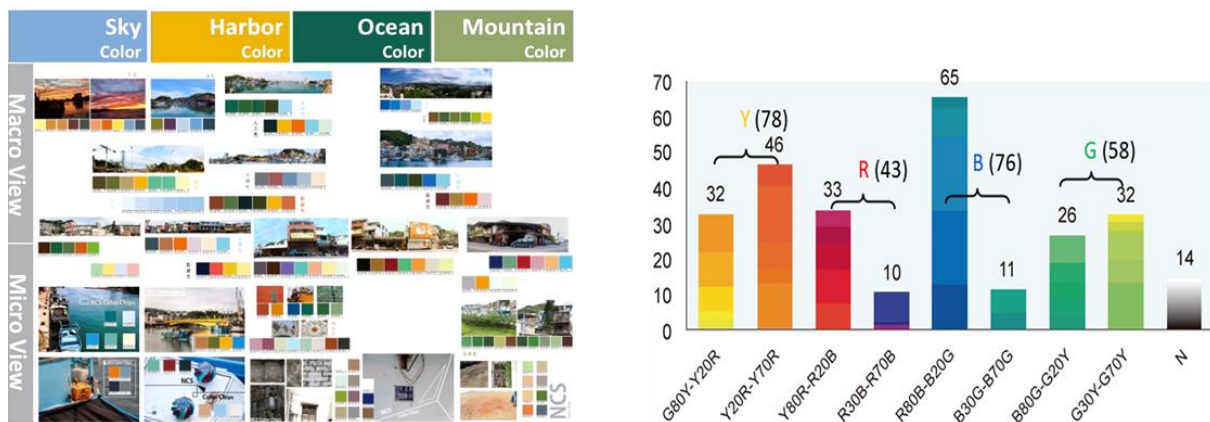

Figure 2: 269 regional colors collected by NCS environmental color survey tool and a histogram color chart showed the distributions of regional color samples.

The overall environmental landscape colors of the Zhengbin Fishing Port region are mainly blue and green, with yellow and brown dotted. The measurements of lightness and chroma distributed from 05~70 and 10~70 accordingly. The domain color hue ranged from R~B90G with medium to low chroma and lightness. The embellishment chroma distributed from G10Y~Y90R with medium to high lightness. The color appearance of the seafront architecture complex's façade is common in gray and brown with an overall lightness distribution ranged from 05~60 (medium to high) and an overall chroma distribution ranged from 00~50 (middle to low). The perceived color imagery of the Zhengbin Fishing Port's landscape tended toward a turbid tone (flat and obscure).

### To establish an environmental color dataset for the color scheme

The results of color survey indicated that the environmental color composition of the Zhengbin Fishing Port area scattered evenly in hue, lightness and chroma, which caused an obscure visual perception on environmental landscape color imagery. Further in-depth analysis on collected colors, it found out that the majority of colors were filled by large-area natural colors with blue-green tone, supplemented by secondary area artificial color with warm tone embellishment, in which contained the high-light and low-low chroma. After the evaluation, the color planner filtered out the redundant color hues from the environment database and selected a total of 55 domain colors from five color categories to establish an environmental color dataset (Figure 3) for the color scheme.

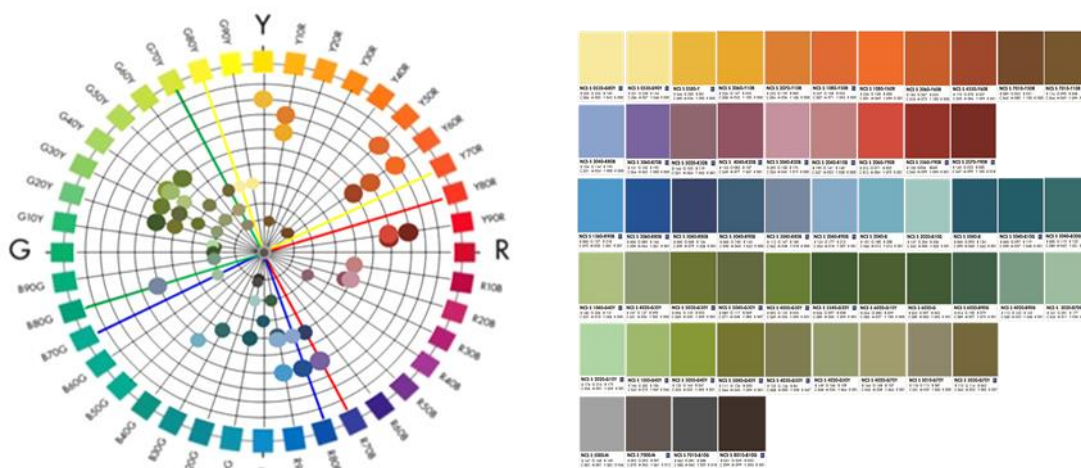

Figure 3: An environmental color dataset established for the color scheme.

### The process to develop a color scheme

According to environmental color analysis along with the opinions of stakeholders, experts and scholars, medium-high lightness and chroma of colors, as well as warm colors, were determined as the key tone for the color façade of architecture complex at Zhengbin Fishing Port.

A color scheme was designed by the color planner, based on color harmony scheme principle, to determine the optimum multi-color combinations on the façade. The final approval of color selection of each building was determined by the residents. There are several houses owners, including no. 523, 527, 529, 537, 551, 561, who chose their preferred colors rather than the color planner's recommendation. Selected target colors for each of houses in the color scheme and an example of a multi-color combinations for the façade of the seafront architecture complex shown on Figure 4. There are color differences between NCS color patches and actual color paints.



Figure 4: A multi-color combinations scheme developed for the façade of the seafront architecture complex.

### Implementation of the color scheme

The following table (Table 1) has shown the color changed on the façade of the seafront architecture complex before and after the implementation of color scheme in each phase during 2017-2019.



























Phase	No. of building	Paint brand	Color Painted
Original (2017)	21	N/A	<div style="display: flex; justify-content: space-around;"> <div style="text-align: center;"> <p>535</p>  <p>NCS S 1080-Y60R</p> </div> <div style="text-align: center;"> <p>557</p>  <p>NCS S 1070-Y20R</p> </div> </div> <p>(existent colors)</p> <p>Note: Both buildings' colors remain unchanged.</p>
First phase (2018)	5		<div style="display: flex; justify-content: space-around;"> <div style="text-align: center;"> <p>*561</p>  <p>NCS S 1050-B40G</p> </div> <div style="text-align: center;"> <p>553</p>  <p>NCS S 0580-Y</p> </div> <div style="text-align: center;"> <p>*551</p>  <p>NCS S 7010-B10G</p> </div> <div style="text-align: center;"> <p>*537</p>  <p>NCS S 1050-B40G</p> </div> <div style="text-align: center;"> <p>*523</p>  <p>NCS S 2070-G50Y</p> </div> </div> <p>Note: 523, 537, 551, 561 chose their preferred colors. 553 accepted the color planner's suggestion.</p>
Second phase (2018)	10		<div style="display: flex; justify-content: space-around;"> <div style="text-align: center;"> <p>559</p>  <p>NCS S 2060-A</p> </div> <div style="text-align: center;"> <p>555</p>  <p>NCS S 2060-Y10R</p> </div> <div style="text-align: center;"> <p>533</p>  <p>NCS S 1080-B20R</p> </div> <div style="text-align: center;"> <p>531</p>  <p>NCS S 1080-Y10R</p> </div> <div style="text-align: center;"> <p>*529</p>  <p>NCS S 1080-Y60R</p> </div> </div> <div style="display: flex; justify-content: space-around;"> <div style="text-align: center;"> <p>*527</p>  <p>NCS S 0580-Y</p> </div> <div style="text-align: center;"> <p>525</p>  <p>NCS S 2060-Y10R</p> </div> <div style="text-align: center;"> <p>521</p>  <p>NCS S 2060-Y10R</p> </div> <div style="text-align: center;"> <p>519</p>  <p>NCS S 2060-Y10R</p> </div> <div style="text-align: center;"> <p>517</p>  <p>NCS S 2060-Y10R</p> </div> </div> <p>Note: Except 527, 529, the rest of residents accepted the color planner's suggestions.</p>
Third phase (2019)	4		<div style="display: flex; justify-content: space-around;"> <div style="text-align: center;"> <p>549</p>  <p>NCS S 1060-G60Y</p> </div> <div style="text-align: center;"> <p>547</p>  <p>NCS S 0530-G90Y</p> </div> <div style="text-align: center;"> <p>545</p>  <p>NCS S 2060-U10R</p> </div> <div style="text-align: center;"> <p>543</p>  <p>NCS S 0580-Y</p> </div> <div style="text-align: center;"> <p>541</p>  <p>NCS S 2060-U10R</p> </div> <div style="text-align: center;"> <p>539</p>  <p>NCS S 0580-Y</p> </div> </div> <p>Note: The residents accepted the color planner's suggestions.</p>

Table 1: The color scheme implemented for the façade of the seafront architecture complex in each phase.

## RESULTS AND DISCUSSION

Figure 5 has shown the results of color harmony analysis for the Zhengbin Fishing Port color scheme. The distributions of each selected color hue, chroma and lightness are plotted and analyzed by NCS colour circle and triangle. Lightness (05~50) and chroma (40~80) of colors mainly range from medium to high, which follow the proposed color scheme design. Each pair of house colors analyzed by color harmony scheme from left to right through the façade.

Although those chosen painted colors are limited to environmental color dataset and residents' color preferences, typical color harmony schemes are still found throughout the color façade, including analogous, complementary, split-complementary, triadic, and rectangle color schemes, etc. It was also found that few colors were disharmonious due to high lightness, low chroma, and high contrast. Those colors were determined by the residents' color preferences (no. 527, 529, 551) or original color (no. 557), which did not match the color planner's design.

In response to the questions regarding color planning and implementation discussed as follows:

1. The Jean-Philippe Lenclos's methodology of color geography adopted into this project proved very effective (Lenclos and Lenclos 1999). Due to the environment limitations, a perfect color harmony of multi-color combination scheme for the façade might be hardly to achieve, but the overall performance of color scheme perceived quite harmonious with environmental landscape colors (Figure 5). Zhengbin Fishing Port color scheme was highly recognized as a successful project that has received the Award of Excellence.
2. This project set up a good example that the domain colors selection for color scheme was decided according to a collaborative conclusion from stakeholders, experts, scholars and the color planner.
3. The final approval of color selection for each building was determined by the residents, not by the color planner or the city government administrators. Personal color preference turned out to be a significant factor influencing the color harmony of color scheme. That's why there is a discrepancy between the reality and the color plan. The communication regarding the consensus of color selection on the façade between stakeholders and the color planner needs to be improved.
4. From the process of color scheme, it is to suggest that the scientific psychophysics experiment method could be used in advance to test the color harmony among different multi-color combinations schemes in order to obtain a more rational color plan additive to the color planner's aesthetical design.

## CONCLUSION

Zhengbin Fishing Port color scheme has captured public attention and compliments after the implementation of project. The new multi-color combinations façade of the architecture complex perceived harmonious with Keelung harbor environmental landscape colors, which indeed enhanced the Zhengbin Fishing Port's regional characteristics and cultural style successfully. It has become a new landmark and tourist attraction, which known as "Zhengbin Color Houses" that inspired from the Italy Venetian island of Burano (colorful island).

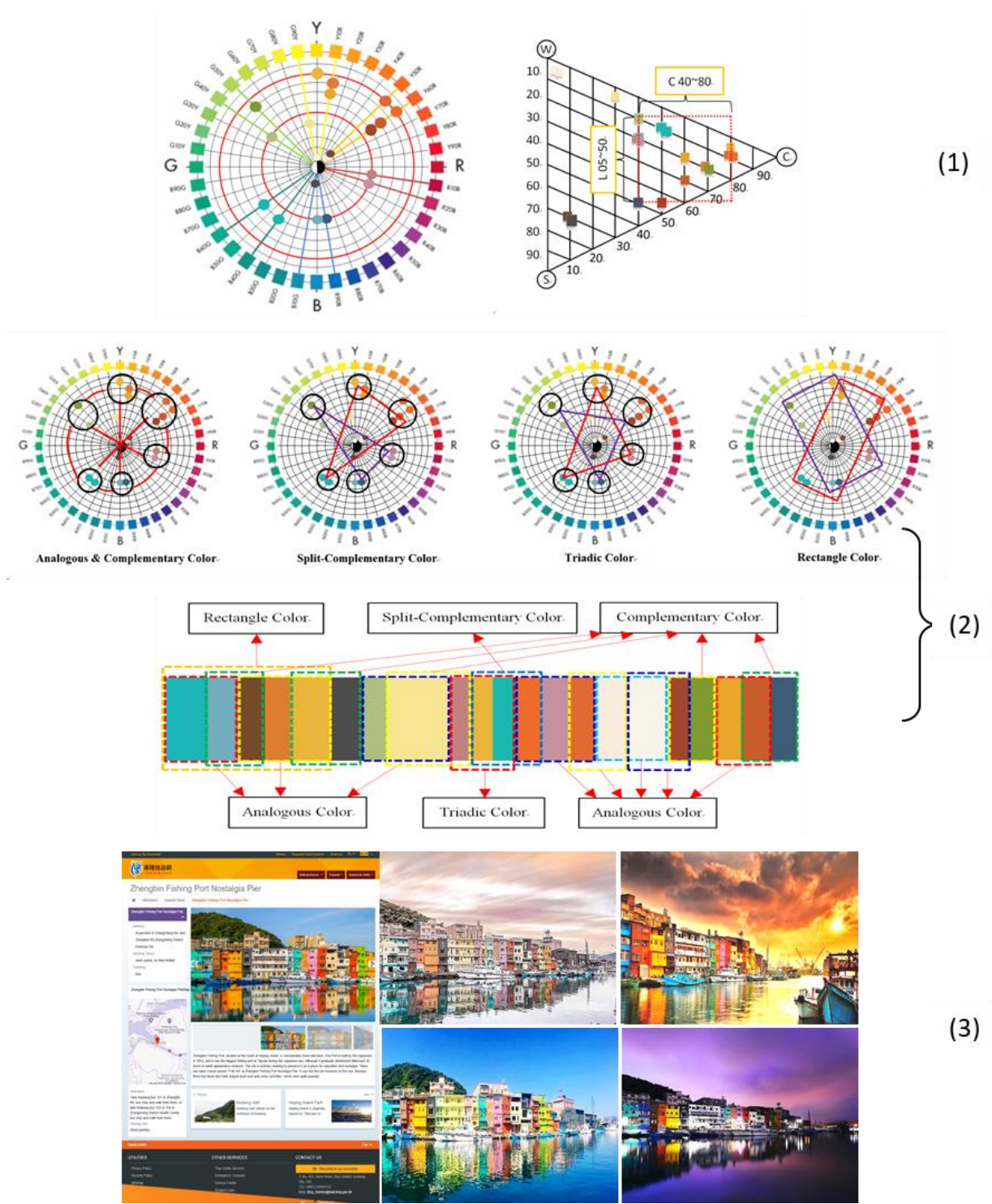

Figure 5:  
 1) The distributions of each selected color hue, chroma and lightness are plotted and analyzed by NCS colour circle and triangle.  
 2) Color harmony schemes analyzed in two, three, four and multiple colors combinations.  
 3) Keelung city government tourist website and popular photos posted by courtesy of the photographers.



## ACKNOWLEDGEMENTS

It is highly appreciated that all the information and materials of the Keelung city government-funded color project provided for this research is overwhelmingly. The photos used in this article by courtesy of the photographers are very grateful as well, including famous Mr. Min-Ming Chen, etc.

## REFERENCES

- Hård, A., L. Sivik, and G. Tonnquist. 1996. NCS Natural Color System - from concepts to research and application. Part I and II. *Color Research and Application* 21: 180-220.
- Lenclos, J.-P., and D. Lenclos. 1999. *Couleurs du monde: géographie de la couleur*. Antony: Éditions du Moniteur.
- Natural Color System. In: [https://en.wikipedia.org/wiki/Natural\\_Color\\_System](https://en.wikipedia.org/wiki/Natural_Color_System).

---

**Note:** This research was presented in poster format at the AIC 2019 Conference in Buenos Aires, and won one of the Robert W. G. Hunt Poster Awards (see Appendix, in this book).

# Colour functions in urban design: communication, identity and user behaviour

Catarina Diz de Almeida<sup>a\*</sup>, Cristina Caramelo Gomes<sup>b</sup>, José Afonso<sup>a</sup>

<sup>a</sup> Universidade de Lisboa, Faculdade de Arquitetura, Lisbon, Portugal

<sup>b</sup> Universidade Lusíada, Faculdade de Arquitectura e Artes, Lisbon, Portugal

\* catarina.diz@gmail.com

## ABSTRACT

Colour transforms user understanding of the space. Throughout its ability to change emotional attachment between users and the urban form, colour can be a powerful tool to regenerate disconnected urban scenarios. However the colour influence as an urbanistic mechanism has been repeatedly neglected, based on its association to aesthetical values plus the difficulty to approach chromatic subject with operative concepts. The critical choice is where to maintain or to change urban colours in order to improve the user experience. Focussed in a contemporary humanistic recommendation it is important to define the performance of colour to functional communication, identity of the urban space and consequently, on user behaviour. From literature and iconographic reviews, confronting urban scenarios with and without colour strategies, this paper aims to clarify what are the colour functions in the public place and how colour can be oriented as a tool for urban regeneration, in order to justify the importance of colour functionality as a regulatory instrument of urban design.

**Keywords:** *colour functions, urban regeneration, communication, identity, user behaviour*

## INTRODUCTION

Color is much more than an aesthetic statement: it is part of a life-giving and life-preserving process. It is part of the terms and conditions under which humans live and experience. Besides other sensory perceptions, humans orient themselves according to optic signals, and learn through visual messages. This makes color vitally important to the meaning of the environment as well as to human interaction with it. (Meerwein et al. 2007: 16)

When correctly used, colour influences humans behaviour and improve the urban experience. Despite this, rarely colour has been considered as a primary instrument of urban design. The

complexity of colour subject, the absence of rules and the lack of operational concepts led urban chromatic choices voted to the authors, owners and municipalities free will.

However, choosing colour to the public place can follow some guidelines in order to improve both, the urban environment and the user experience. But these guidelines need to be visual and conceptual systematized to become more operational to professionals, municipalities and individuals.

To realize the potential of colour to the urban planning it is necessary to identify how colour is present and how it influences us during the urban experience.

Colour is important to communication. As quoted by Lynch (1960), colour can be used as a guiding mechanism which alters the space readability. Side by side, in a place with and without wayfinding measures, the user felt oriented or lost. Also, focal points and strategic repetitions can be applied according to Gestalt and Itten's theories to capture the sight and to decode the urban functions.

In the same way, colour is important to identity. By recognising or creating the colours of a place it is possible to construct meaning and strengthen the sense of belonging. Imageability is the concept that enriches the user connection to the place. On the one hand, we can survey of the existing colours and identify the predominant. On the other hand, and in the absence of a more effective strategy, the chromatic contrasts can create the elements for a new identity.

Also, colour reveals a substantial impact on user behaviour. From interaction of the previous concepts – communication and identity – the user is more closely related to the environment that he perceives and identifies with. Colour links these factors by manipulating the perception of peaceful or over stimulating environment. For this reason it is fundamental colour research oriented to humanist principles to support urban regeneration, bringing the cities of the past to the living models of the future.

## COLOUR COMMUNICATION

Colour could introduce elements of identification in order to clarify hierarchy, morphology and typology of urban space and architecture, improving spatial orientation and the understanding of relevant architectural elements and rhythms. (Aguiar and Pernão 2010: 130)

In urban context, colour can work as communication device to identify functions easily, especially when related to the morphological characteristics of the place. And also, it can contribute to answering the physiological and safety user requirements, as stated by Maslow Pyramid.

In *The art of color* Itten (1961) identifies the mechanisms to manipulate perceptive balance through colour contrasts by: saturation; light-dark; proportional; complementary; simultaneous; hue; primary hues and hot-cold chromatic relationships. This mechanisms can be applied in urban context in order to identify functions and manipulate feelings, inducing legibility (Lynch 1960: 12-16), imageability (Lynch 1960: 19-23) and easy orientation (Lynch 1960: 118-120) as mean of interaction between the user and the environment.

The impact of colour in relationship between visual perception and user reaction has been study for interior ambiances, for work places (Küller et al. 2006), hospital (Dijkstra et al. 2008) or with “*baker-miller pink*” to control aggressive behaviours in prisons, and less for outdoors environments. However, some of this concepts and methodologies may be transposed to the public place.

Hence, the chromatic tools to manipulate the perception of the urban environment, and the ways to approach the subject, need to be systematized through wayfinding measures (Gibson 2009),

stimulus balance (Kopec 2012), Gestalt theory and harmony and contrast interactions as recommended by Itten, explained by Zena O'Connor (2011) and recorded by Larissa Noury (2008).

**COLOUR IDENTITY**

A city, a square, a street makes a unique impression on those who experience it. To the feeling that each place has a unique layout contributes not only the morphology and the design, but also the repetition of colours and elements. Colour in urban context has an identity function, therefore, this is a controversial issue.

On the one hand, associated with semiotics, preservation of existing colours can contribute to the continuity of the values of a given territory. In this context, the concept of *colour identity* proposed by Johny Xu (2016) is presented as the persistence of certain colours in the urban environment, which in detriment of others, by their impact on the communities contribute to the sense of belonging. Also, Veronica Zybaczynski (2014) reiterates the importance of colour in preserving local identity through the use of repeated patterns and relates them to sustainability.

Following this line, headquartered at Lusiada University of Lisbon, the research project “The colour of Ajuda” sought to relate the morphology of the buildings with the constructive time and the associated colour (Figures 1 and 2). The purpose of this survey was to establish chromatic constants associated with each design and construction time.

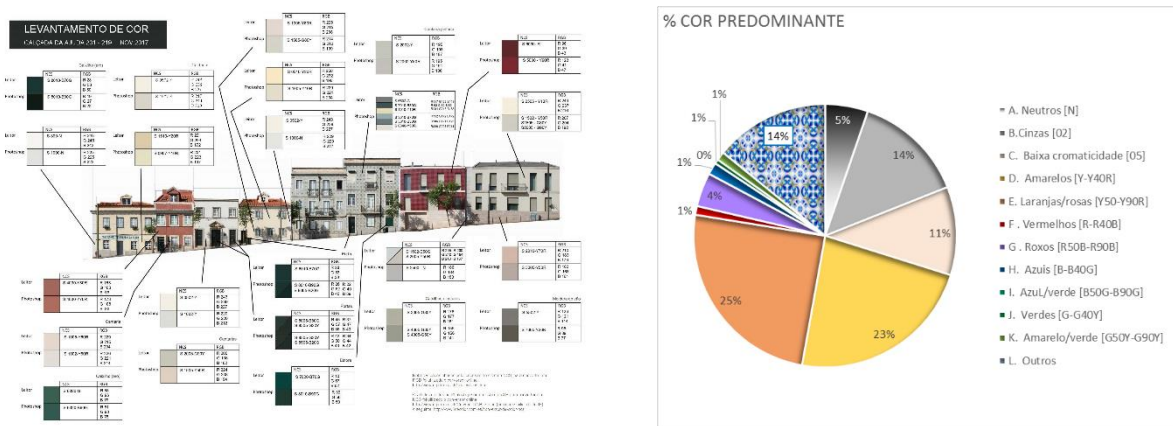

Figure 1: Colour survey and predominant colour analysis, research project “The colour of Ajuda”.

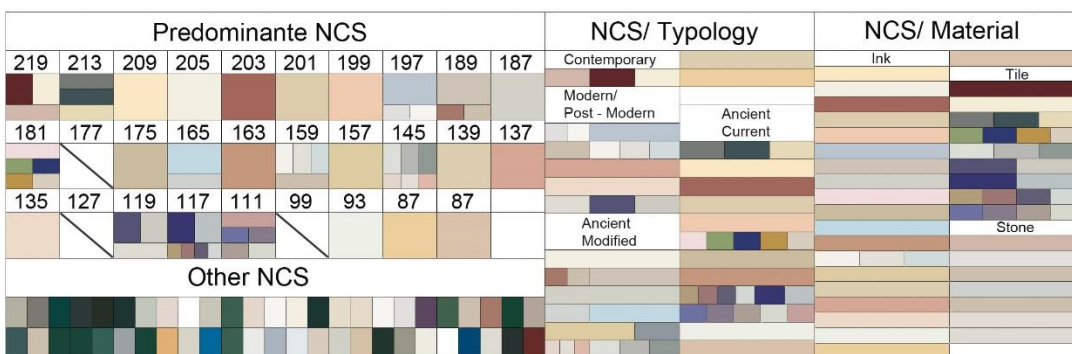

Figure 2: Colour analysis by predominant, typology and façade material, research project “The colour of Ajuda”.

On the other hand, the current colour offering is completely different from erstwhile, the functions distinct, and the requirements as well. Some places, with a confusing urban image, need regulatory mechanisms. The introduction of new chromatic palettes can evoke new identities, or transform disconnected territories into cohesive urban forms.

Nowadays, that it is on the agenda the discussion of the revitalization of public place focused on quality of life, also the colour choice should serve to enhance the urban environment. However, rarely these colour potentials are equated as tools for a new urban planning.

Küller schematically demonstrates how to change readability by relating perception and wellbeing in a given space according to physiological and psychological principles, and proves that “every change in the space surrounding man can be observed in his own organism” (1976: 154).

In this framework, the function of urban colour is related to wellbeing, through the power of colour to make space intelligible, functional and appealing. Where and what for we can/should change the palettes is an open discussion, which involves in-depth knowledge of the place and users.

## COLOUR AND USER BEHAVIOUR

People’s experience of the urban environment directly influences their emotional attachment to a location and ultimately satisfaction with the living conditions. The challenge for contemporary designers is to understand how the psychological experience could be designed to positively influence people’s perception of urban space, and contribute to their well-being. This allows a reflection on what could be a health-conscious approach to environmental design. (McLellan and Guaralda 2014: 1)

Colour contains a double dimension: cognitive and emotional. How colour is applied influences and conditions human behaviour, physical wellbeing and psychological comfort. (Meerwein et al. 2007: 74). The colour used with discretion can and should serve for the “humanization of the built environment” (Caramelo Gomes et al. 2013), and by exchanging stimuli with the surroundings (Meerwein et al. 2007), promoting inclusion, autonomy and personal fulfillment.

Nowadays, urban humanistic concepts proliferate. The expressions as *people friendly cities*, *slow cities*, *walkable cities*, *urban happiness*, *livability* are used by several authors (Kamp et al. 2003, Gehl 2010, Bai et al. 2012, Urban age 2011, Liu et al. 2016, Adams 2014), which since the turn of the new millennium talk about the relationship between the quality of urban space and the users wellbeing.

These expressions demonstrate the power of colour to connect urban space and human behavior. As long as colour guides human behavior it contributes also, to a sense of belonging and personal fulfillment, in a dynamic relationship between color, user and urban environment.

As proved in practice by changing colours in social housing, colour “could be efficiently used to help to restore the self-esteem and sense of belonging of the inhabitants” (Aguiar and Pernão 2010: 129).

The *color loci placemaking* that Cristina Boeri (2017) talks about is connected to this humanist colour approach, that colour could be used as an instrument of inclusion, orientation and identification, as proposed by Margarida Gamito (2011).

In Portugal, the chromatic rules associated with urban planning are scarce and based on inaccurate guidelines, such as maintaining the color of doors and windows, “respecting” dominant colors or using colors that guarantee the chromatic balance of the street and the street block. But does the color in the doors and windows fulfill its function? How is the “respect” for dominant colors

operationalized? And what is the definition of color balance in an urban space? These questions remain unanswered...

## **COLOUR FUNCTIONS AND URBAN DESIGN – DISCUSSION**

Cities, like all environments, are built for people and a basic question is what should a desirable environment be for a given group of people at a given time in a given place? Environmental quality is at the heart of the objectives of planning and design (the what and why of planning and design) since all planning and design interventions are for the purpose of creating a better environment. The question is what is 'better' and for whom? (Rapoport 1983: 46)

Whatever function, or functions, of the color we need to plan—in communication, identity and user behaviour—the aim will always be to induce perceptions of urban space that will make us happy and fulfilled. The highest purpose is to use colour to guide the visual sense, ground the perception and assimilation of forms, and then select values and mechanisms that influence the feeling and enjoy the public space.

To achieve this objective Rapoport (1983) defends the preference for complex urban environments, built by repeating patterns—humans and urbans—with hierarchies in visual perception. Based on this theory, to preserve the territorial socio-cultural values, it is fundamental to use this repeated patterns in urban planning.

Current urban planning must be aware, apart from design and style preferences, human heterogeneity, needs and expectations, to improve the quality of life of city users. These humanistic values should also be considered in colour planning. The chromatic palette choice for the urban space is not supported by one size fits all or a magical formula that facilitates the job. Rules absence and the lack of operative concepts support the environmental cluster performance based on personal choices and historical trends. Literature review highlights that colour induces sensations, emotions and behaviours, it provides favourable emotional reactions (satisfaction, arousal and calmness), in line with the neuromorphic concepts of architecture quoted by Bil et al. (2018).

But, if it is so easy to understand the value of colour planning for improving living conditions, why so many urban places remain chromatic overload or, contrariwise, discolored or aseptically white?

It is not easy to answer to these questions. Still, we do believe that urban planning must define the goals for each area in a time frame - based on its functions and users' performances patterns - and based on the knowledge available and disseminated about colour, set up chromatic schemes to implement, develop and evaluate. Good practices must be reported and disseminated towards new experiences and the improvement of the quality of life that urban space can offer to its users.

## **ACKNOWLEDGMENT**

This work is financed by national funds by FCT - Foundation for Science and Technology, under the Project UID/AUR/04026/2019.

## REFERENCES

- Adams, M. 2014. *Quality of urban spaces in wellbeing. Wellbeing: a complete reference guide*. Online: <https://onlinelibrary.wiley.com/doi/pdf/10.1002/9781118539415.wbwell064>.
- Aguiar, J., and J. Pernão. 2010. Colour and participative process in urban requalification. Colour studies for social housing in Portugal. Online: [https://www.academia.edu/543961/Colour\\_and\\_Participative\\_Processes\\_in\\_Urban\\_Requalification\\_Colour\\_Studies\\_for\\_Social\\_Housing\\_in\\_Portugal](https://www.academia.edu/543961/Colour_and_Participative_Processes_in_Urban_Requalification_Colour_Studies_for_Social_Housing_in_Portugal).
- Bai, X., I. Nath, A. Capon, N. Hasan, and D. Jaron. 2012. Health and wellbeing in the changing urban environment: complex challenges, scientific responses, and the way forward. *Current Opinion in Environmental Sustainability*. Online: <http://dx.doi.org/10.1016/j.cosust.2012.09.009>.
- Bil, J., B. Lauz-Roszak, and P. Gorczyca. 2018. Interactions between neurology and architecture – creating the built environment and its impact on the brain. *Archives of Medical Science*. Online: <https://doi.org/10.5114/aoms.2018.79142>.
- Boeri, C. 2017. Color loci placemaking: The urban color between needs of continuity and renewal. *Color Research and Application*. Online: <https://doi.org/10.1002/col.22128>.
- Caramelo Gomes, C., L. Santos, and B. d'Almeida. 2013. Humanização em ambiente construído: O estímulo dos sentidos. Online: <http://www.educacaografica.inf.br/artigos/humanizacao-em-ambiente-construido-o-estimulo-dos-sentidos>.
- Dijkstra, K., M. E. Pieterse, and A. Th. H. Pruyn. 2008. Individual differences in reactions towards color in simulated healthcare environments. *Journal of Environmental Psychology*. Online: <https://doi.org/10.1016/j.jenvp.2008.02.007>.
- Gamito, M. 2011. Cor no mobiliário urbano um factor de Inclusividade, orientação e edentificação. PHD, FAUTL.
- Gehl, J. 2010. *Cities for people*. London: Island Press.
- Gibson, D. 2009. *The wayfinding handbook*. New York: Princeton Architectural Press.
- Itten, J. 1961. *The art of color: the subjective experience and objective rationale of color*. New York: Reinhold Publishing.
- Kamp, I., K. Leidelmeijer, G. Marsmana, and A. Hollander. 2003. Urban environmental quality and human well-being. Towards a conceptual framework and demarcation of concepts; a literature study. *Landscape and Urban Planning*. Online: [https://doi.org/10.1016/S0169-2046\(02\)00232-3](https://doi.org/10.1016/S0169-2046(02)00232-3).
- Kopec, D. 2012. *Environmental psychology for design*. New York: Fairchild Books.
- Küller, R. 1976. The use of space – some physiological and philosophical aspects. In: Strasbourg Conference. Louvain-la-Neuve: CIACO, 154-163.
- Küller, R., S. Ballal, T. Laike, B. Mikellides, and G. Tonello. 2006. The impact of light and colour on psychological mood: a cross-cultural study of indoor work environments. *Ergonomics*. Online: <https://doi.org/10.1080/00140130600858142>.
- Liu, Y., J. Kang, Y. Zhang, D. Wang, and L. Mao. 2016. Visual comfort is affected by urban colorscape tones in hazy weather. *Frontiers of Architectural Research*. Online: <http://dx.doi.org/10.1016/j.foar.2016.10.001>.
- Lynch, K. 1960. *The image of the city*. Cambridge, MA: The MIT Press.
- McLellan, G., and M. Guaralda. 2014. Environmental colour and well-being. In: International Conference On Art, Architecture And Urban Design. Online: <https://eprints.qut.edu.au/79910/>.
- Meerwein, G., B. Rodeck, and F. Mahnke. 2007. *Color – Communication in architectural space*. Basel: Birkhäuser.

- Noury, L. 2008. *La couleur dans la ville*. Paris: Éditions du Moniteur.
- O'Connor, Z. 2011. Façade colour and judgements about building size and congruity. *Journal of Urban Design*. Online: <https://doi.org/10.1080/13574809.2011.574993>.
- Rapoport, A. 1983. Environmental quality, metropolitan areas and traditional settlements. *Habitat International*. Online: [https://doi.org/10.1016/0197-3975\(83\)90033-4](https://doi.org/10.1016/0197-3975(83)90033-4).
- Urban age, ed. 2011. *Cities, health and well-being: Conference report*. Online: [https://lsecities.net/wp-content/uploads/2012/06/Cities-Health-and-Well-being-Conference-Report\\_June-2012.pdf](https://lsecities.net/wp-content/uploads/2012/06/Cities-Health-and-Well-being-Conference-Report_June-2012.pdf).
- Xu, J. 2016. *How colour defines local identity: A comparative case study of London and Shanghai*. PHD in Arts. School of the Arts, English and Drama. Loughborough University, UK.
- Zybaczynski, V. M. 2014. Colour – Important factor in preserving the local identity. *Urbanism. Arhitectură. Construcții*. Online: <http://uac.incd.ro/Art/v5n4a12.pdf>.



# Color and housing: a study of the chromatic aspects of the social mass housing complexes

Natalia Naoumova<sup>a\*</sup>, Marina Mendonça Loder<sup>b</sup>

<sup>a</sup> Federal University of Pelotas (UFPel), Pelotas, RS, Brazil

<sup>b</sup> Federal Institute of Education, Science and Technology Sul-Rio-Grandense (IFSul), Pelotas, RS, Brazil

\* naoumova@gmail.com

## ABSTRACT

This study explores the colors of the social mass housing complexes. The purpose is to investigate the chromatic characteristics of facades, which affect the aesthetic quality of residential buildings. The case study was performed in the city of Pelotas, Rio Grande do Sul state, Brazil. The research consisted of two stages: first, an analysis of principal physical and chromatic characteristics of the buildings was carried out and identification of color structure typologies was performed; second, resident preferences with respect to attributes of the chromatic typologies were evaluated. The research made possible to understand how residents perceive the buildings, especially relationship between their formal and chromatic components. It was shown that residents prefer cool range of colors, emphasizing the green tones, as opposed to what currently prevails in the housing complexes. In the terms of the chromatic distribution, a prominence of relief elements achieved by contrasting colors was preferred painting scheme.

**Keywords:** *color study, aesthetic quality, social housing, environment perception*

## INTRODUCTION

Public policies concerning housing of social interest in Brazil focus, in their proposals, the combat to quantitative housing deficit and, thus, as a priority, the economic aspects in the construction of building and housing complexes. However, in many works, the visual appearance of these collective residences is criticized as it fails in visual aspects and does not meet the aesthetic expectations of the residents (Lay 1992, Moura and Chiarelli 2010, Bonduki 1998, Segawa 1997). The visual problems of these residences refer to a perception of dryness, monotony of forms, absence or redundancy in colors and materials. The buildings are characterized by the simplicity of formal composition and the repetition of the facades plans. The environments produced with such characteristics lack in quality and often are not attractive due to the excessive repetition of their buildings, which do not differ one from the others. The lack of variability and the personalization of the space are often pointed out as

a negative factor in the perception of these places. The extension of the areas occupied by collective housing in the city is significant. Thus, its visual appearance influences not only the attitude of the population living in such areas, but it also affects the image of the city as a whole.

Color is configured as a determining element in the urban environment as it may significantly influence the perception of order and variability in the facades and, therefore, it contributes in the perception of the aesthetic quality of the buildings. Literature indicates that the order and the variability of the formal composition, opposed to the monotony and repetition, are important characteristics of the aesthetic experience, for a satisfactory visual perception of the buildings and housing complexes (Reis et al. 2010, Nasar 1998).

In this context, surveys of color data become necessary as a first step to clarify the present situation of color application in collective buildings with repeated formal typologies. This may help to reveal the main aspects which should be considered in the proposal of colors for low-income housing constructions based on the formal and perceptual specificities.

The general purpose of this study is to investigate the chromatic characteristics of the building facades that affect the aesthetic quality of residential buildings. The three aspects were considered significant for the study: 1) color palettes and chromatic combinations used; 2) the interaction between form and color (distribution of colors in the facades) and 3) the perceptual questions linked to the evaluation of the chromatic characteristics of the buildings by users of the housing complexes.

## EXPERIMENTS

The study considered the present coloring of 95 residential buildings in the city of Pelotas, state of Rio Grande do Sul, built between 1956 and 2008. The city was chosen for investigation as it has a significant collection of housing complexes produced in different phases of development of governmental housing programs (Moura and Chiarelli 2010). The buildings, which comprise the studied housing complexes, have simplified formal characteristics. They are usually composed of rectangular blocks with rectilinear forms and some present a “C”, “H” or “U” shape. The facades are commonly flat with straight lines, with few recesses or protrusions and do not have details that value their form.

The investigation was conducted in two ways. The first focused on the physical environment and surveyed the existing chromatic situation. The other emphasized the evaluation carried out by the people, residents of the housing complexes. In this study, in order to discover the standards of color use, we tried to relate the chromatic characteristics to the form of the buildings and to the specific elements and line that mark the facades of these constructions.

The studies were based on the color theory (Küppers 1982, Itten 1961), having as its main point the concept of urban polychromy developed by Efimov (1996). Based on urban studies on the geography of color carried out by Lenclos (1995) and chromatic typologies of architectural styles carried out by Naoumova (2009), the criteria for the characterization of the facades were elaborated. The following characteristics were observed: 1) *color-attribute* (hue, lightness, saturation); 2) *color-temperature* (warm and cool tones); 3) *color-location* (distribution of colors on the background walls and details); 4) *color-combination* (monotone, contrasting or nuance chromatic relationship); 5) *color-typology* (relation between color and the form of division of the facade lines). This last category included 5 types: a) schemes without division with a single color; b) with horizontal stripes; c) with thin vertical stripes; d) with wide vertical areas; e) with use of two types of stripes, vertical and horizontal simultaneously, called mixed schemes. The housing complexes were classified by year of

construction, layout, amount of blocks and degree of convexity of the facades according to Medvedovski's data (2010).

In the second part of the study, we verified how the perception of the degree of pleasantness and attractiveness of the facade colors influence the degree of satisfaction with the visual appearance of the building complexes. The chromatic preferences of the residents in relation to the formal variables of the painting schemes, specifically connected to contrast and complexity of color combinations, were investigated. For this purpose, questionnaires were prepared and used to interview 150 residents of three complexes, selected in the general sample. The results were processed using non-parametric statistical tests for data analysis included in the Statistical Package for the Social Science (SPSS).

## RESULTS AND DISCUSSION

### Chromatic surveys of the existing situation

The color measurements in the facades were carried out through the international system of color classification, named Natural Color System – NCS (Hård 1976). All colors surveyed were found in the space of the NCS and visualized through the color circle and color triangle, resulting in individual graphics (by housing complex) and summary graphics (where colors have been grouped by specific characteristics). That way, the existing chromatic trends in the painting of buildings of housing complexes were highlighted (Figure 1).

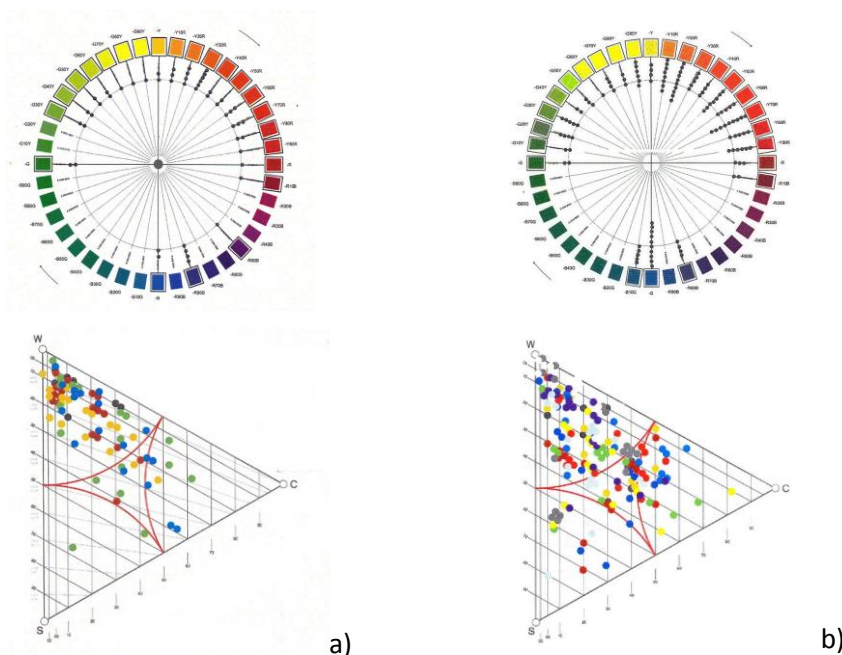

Figure 1: Chromatic characteristics of the facades of housing complexes in the city of Pelotas (1956-2008): a) the predominant colors in the background walls, b) the predominant colors in the details. Source: Loder (2013).

With a focus on the relation *color-attribute* (hue, lightness, saturation) in the biggest areas of the facades, the results revealed that the walls of the buildings of housing complexes of the city of Pelotas in 83.2% of the cases are painted with light colors. The concentration of the colors in the top of the NCS triangle confirms this observation. It has also been noticed that the very saturated colors,

similar to the darker ones, are not often used in these parts of the facades (5.6% and 1.8% respectively). The location of a group of colors in the central zone of the NCS triangle shows a small portion of the buildings (9.3%) painted with medium lightness colors (which are neither too saturated nor too dark).

In the observation of the *color-temperatures*, the proportion and the amount of warm and cool shades was compared. The results revealed a significant difference, exposed that 82% of the colors used in the background walls are warm, close to yellowish, orange and reddish shades (NCS codes ranging between -G70Y and -R20B). There was also a small proportion of cold shades, greenish (NCS codes ranging between -G and -G60Y) and bluish (NCS codes -B and -R80B), which were similar in their percentages (8% each).

In the analysis of *color-location*, the results pointed out a significant difference between the colors of the details comparing to the shades found in the background wall of the facades. As details, in this study, we understand as smaller elements and surfaces, protruding or reentrant, of the facade such as beams, bars, cornices and niches. The more centralized distribution of colors in the NCS triangle unveiled the increase in the amount of shades of medium lightness, with a total of 29%. Despite the predominance of light colors in the details, its percentage reduced significantly reaching only 58.7%. The increase of saturated (11%) and dark shades (21.3%) and the wider variety of hues was similarly quite clear in these elements (Figure 1b).

The study of the *chromatic combinations*, analyzed in terms of presence of contrast or nuance relationship, highlighted a similar percentage of two combinations, with a small predominance of nuance (52.34%). However, the observation of the colors directly on the facades revealed that the darker color was usually found on the details and the lighter one on the background of the walls.

In terms of *color-typology*, the results show that the most representative of the facades are the schemes with *wide vertical areas* (30%) and schemes with *mixed stripes* (28%). They are followed by schemes which have horizontal stripes (17.8%). With lower percentages we find the typologies with *thin vertical stripes* (8.4%) and the monochromatic schemes with *one single color* (6.5%) (Figure 2).









One single color	Horizontal stripes	Thin vertical stripes	Wide vertical areas	Mixed schemes	Others
					
					
Conj. Duque de Caxias, 1963	Edif. Almirante Barroso, 1969	Coohabpel (1), 1966	Edificio Ipase, 1956	Coohabpel (2), 1966	Residencial Tiradentes, 1965
6.5%	17.8%	8.4%	30%	28%	9.3%

Figure 2: Example of structural typologies found in the housing complexes in the city of Pelotas (1956-2008). Source: Loder (2013).

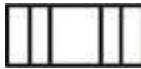
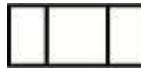
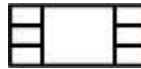
### Evaluative analysis

In all studied housing complexes, significant correlations between the degree of *satisfaction* with the complex and the perception of *pleasantness* of color of the buildings were found. The same occurred for the degree of *attractiveness* and *satisfaction*. This means that the more pleasant and attractive in terms of color the facades of the buildings of the researched housing complexes are perceived, the

higher is the level of satisfaction of the people with the visual appearance of the complex and vice-versa. The level of *maintenance of the facades* and combination evaluated as *harmonic* similarly had positive relations with the degree of *satisfaction* (Table 1).

Name of the housing complex	Relation of satisfaction with the housing complex and follow variables:			
	Color pleasantness	Color attractiveness	Paintwork maintenance	Harmonic color combination
Coohappel	0.625, sig = 0.000	0.458, sig = 0.001	0.555, sig = 0.000	-
Coohaduke	0.333, sig = 0.018	0.606, sig = 0.000	0.582, sig = 0.000	0.480, sig = 0.000
Guabiroba	0.453, sig = 0.001	0.436, sig = 0.002	0.624, sig = 0.000	0.451, sig = 0.001

Table 1: Correlations (Spearman's rho) between satisfaction and studied variables. Source: Loder (2013).

Concerning *symbolic evaluations*, the results highlighted that the contrasts of the colors of the facades increase the potential of *attractiveness* and contribute for the attribution of meanings such as *happy* and *friendly* for the housing complex visualized. And the absence of color and lack of maintenance of the facade painting in one of the complexes studied resulted in an evaluation as *sad* and, in some cases instigated the perception as *dangerous*.

When analyzing the *preferences of the residents for the ideal color* for the painting of the buildings of their complex, similarities in the choice of colors were noticed. The most indicated colors, in the entire set of the respondents, were the cool hues, specially greenish and bluish. Warm colors such as yellowish were also the favorite among the some of residents. However, this colors occupied third place in the ranking of the answers. It is possible to observe that, in any of the complexes, the current color of the buildings was identified with the highest rate of indications.

In the evaluation of the respondents, the *structural typology* indicated as the favorite one was the *mixed scheme* (Figure 3d). Of all 150 respondents, 35.3% chose it as *the most beautiful* of the typologies presented. Another typology indicated more often was the *scheme with vertical stripes* (23.3%) (Figure 3c). It is also interesting to observe that, besides the traditional schemes, the significant number of people showed a preference for the structural scheme with *unsorted stripes* (camouflage type) (Figure 3e). Of the total sample, 22% of the respondents chose this model, considering it as the *most beautiful* of all for plain facades without details. It was also noticed that, among the architects, the possibility of other options of painting of the facades, such as the graphic camouflage, is not considered as an adequate option that could provide more attractiveness to the buildings of housing complexes.

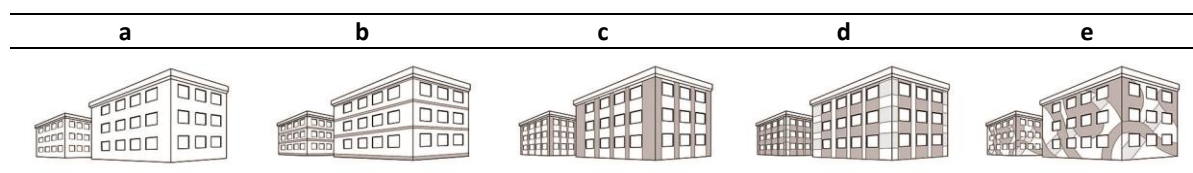

Figure 3: The structural typologies analyzed by respondents. Source: Loder (2013).

## CONCLUSION

The carried out surveys allowed to form a large database and identify the tendencies in terms of use of colors in facades of housing complexes in the city of Pelotas. Data showed that, currently in the buildings, there is a predominance in the range of warm colors, both on the background walls and on

the details. Concerning chromatic structuring, the study highlighted two tendencies of painting: 1) emphasize the protruding and/or reentrant elements with strong colors opposing the painting in a single color, and 2) predominance in the use of light colors on the walls and dark ones on the details. In the housing complexes with several blocks, the repetition of the same shades, with no differentiation and identification of the constructions by color components happened very often.

The research data confirmed that the *satisfaction* with the visual appearance of the housing complex is influenced in several variables related to the color of the buildings, such as: pleasantness, attractiveness (connected to the type of contrast), the maintenance of the painting and the harmonic combination. It was also highlighted that the favorite colors for most of the respondents for the painting of the facades are cool colors (green and blue), in opposition to warm colors, more used in the city housing complexes nowadays.

It is expected that the chromatic study carried out serves for a better understanding of the problems related to the aesthetics of the polychromy of housing complexes, and can be used for the development of new projects that would provide improvements in the visual quality of these residences thus contributing for the well-being of city residents.

## REFERENCES

- Bonduki, N. 1998. *Origens da habitação social no Brasil*. Sao Paulo, Estação Liberdade: FAPESP.
- Efimov, A. V. 1990. [*The city polychromy*]. Moscow: Stroiizdat.
- Hård, A. 1976. The Natural Colour System and its application to interior and exterior environments. In: *Color for architecture*, T. Porter and B. Mikellides, eds. New York: Van Nostrand Reinhold, 109-122.
- Itten, J. 1961. *The art of color: the subjective experience and objective rationale of color*. New York: Reinhold Publishing.
- Küppers, H. 1982. *Basic law of color theory*. Woodbury, NY: Barrons.
- Lay, M. C. 1992. *Responsive site design, user environmental perception and behaviour*. Post Graduate Research School, School of Architecture, Oxford Brookes University, Oxford, doctoral thesis.
- Lenclos, J.-P., and D. Lenclos. 1995. *Les couleurs de l'Europe: géographie de la couleur*. Antony: Éditions du Moniteur.
- Loder, M. 2013. *Cor e habitação: um estudo dos aspectos cromáticos nas fachadas de conjuntos habitacionais da cidade de Pelotas-RS*. PROGRAU, Universidade Federal de Pelotas, Pelotas, master thesis. <https://drive.google.com/file/d/1nn5ZnOQNVYXTttnbJ6LvBIIRhiLieGMCL/view>.
- Medvedovski, N. S. 2010. Geração de indicadores de qualidade dos espaços coletivos em EHIS. Chamada Pública - MCT/FINEP/FNDCT/CAIXA - HABITARE - 01/2006. *Relatório Técnico*. Pelotas, RS: NAUrb/FAUrb/UFPel.
- Moura, R. M. G. R., and L. M. A. Chiarelli. 2010. Banco de dados: Conjuntos habitacionais licenciados em Pelotas: 1956-2008. Pelotas: UFPel.
- Nasar, J. L. 1998. *The evaluative image of the city*. London: SAGE.
- Naoumova, N. 2009. *Qualidade estética e policromia de centros históricos*. Universidade Federal do Rio Grande do Sul, Porto Alegre, doctoral thesis. <https://lume.ufrgs.br/handle/10183/16472>.
- Reis, A. T., C. Biavatti, and M. L. Pereira. 2010. Levels of order and visual stimuli in urban scenes: aesthetic evaluations. In: *21st Biennial Congress of the International Association of Empirical Aesthetics + Design*, Dresden: IAEA.
- Segawa, H. 1997. *Arquiteturas no Brasil, 1900 a 1990*. Sao Paulo: EDUSP, Coleção Acadêmica.

# The chromatic intervention as a proposal of urban image design for university contexts: the case of Coapinole, Puerto Vallarta, Jalisco, Mexico

**Alberto Reyes González, Andrés Enrique Reyes González, Jimena Vanina Odetti**

Instituto Tecnológico Mario Molina, Unidad Académica de Puerto Vallarta, Jalisco, México  
alberto.reyes@vallarta.tecmm.edu.mx  
andres.reyes@vallarta.tecmm.edu.mx  
jimena.odetti@vallarta.tecmm.edu.mx

## **ABSTRACT**

The present work suggests the chromatic intervention, as a proposal for the design and improvement of the urban image in the contexts of university campus, in the city of Puerto Vallarta, Jalisco, Mexico. It is proposed to conceive color as an element of intervention to trigger the development of university contexts in the urban borders of the city. At the same time, color is considered as an articulating element of the urban fabric with the surrounding neighborhoods, in a city with tourist characteristics and with unequal degrees of development.

For the chromatic intervention, a methodology of qualitative research and action research is proposed that contemplates the color as an integrated element to the study of the urban image and the infrastructure of the context of the university campus taken as a case study. The starting point was an integral diagnosis, to identify and select the areas to intervene, to involve the community with the participation of the stakeholders, to formulate an intervention proposal based on the existing contextual development.

The proposal of a chromatic intervention as part of the improvement of the urban image design in these contexts of edges of city, means that it constitutes, not only the visual memory of an urban area, but the living image of the city, the experiences of its inhabitants and how they interact together with the colors, in their streets, their squares, their constructions, the natural context, their facades and their textures. It is emphasized here how all these elements, highlighting color, play a preponderant role in the configuration of the identity of a space or a certain area, and in the urban cultural construction of it.

The results, coming from the study and chromatic intervention, show the necessity in the contexts in which the public universities are installed, to generate improvements for the inhabitants and for the users, as products of a joint action, established between the university and the different social actors that participate in the community.

**Keywords:** *urban color, urban image, color and urban edges*

## **INTRODUCTION**

Color, understood as an essential element of visual language and design, is part of the context in which the urban develops. The colors of a city make up atmospheres that make everyday chores visible, through them, we can understand the ways of inhabiting, perceiving, understanding and giving meaning to the spaces, we live or visited. “The colors of a city become part of the daily construction of cultural identities, concentrating memories and values from the landscape, facades, streets, neighborhoods and neighbors” (Odetti 2019: 12).

The city of Puerto Vallarta is located on the north coast of the Jalisco state, in Mexico. Since the 1990s, it has presented a demographic urban and tourist expansion growth that has positioned it as an international tourist destination. The image that has been built and projected to the world is a sun and beach destination with characteristics of traditional Mexican village (especially this image has been concentrated in the downtown). However, there are segregated areas around this tourist sector of the city that present wide differences, even in situations of marginality, whose conditions of urban infrastructure, services and planning would seem to be forgotten or the fate of the new territorial speculations by the market (Odetti 2019).

Currently in this city, there are two public education institutions: the Centro Universitario de La Costa, Universidad de Guadalajara, and the Instituto Tecnológico Mario Molina, Puerto Vallarta. Both university campuses are located in the urban border contexts. The shortcomings in these contexts range from the attention of public lighting, sidewalks, shops, drains, garrisons, paving, ramps and public transport . To this list, is added the attention to the way in which the elements of the urban image are configured, at the edges of a tourist city, the contexts of university campuses are analyzed, with characteristics of disintegration and marginality. In this work, it is proposed to place special emphasis on the study and proposal of chromatic intervention in the studied areas, as a visual element of the urban image and as a component of the identity formation and symbolic expression of urban life.

## **THEORY**

As main axes, it is proposed to analyze the social perception of the urban landscape as a prominent element of the research. From the urban image the cut of the city reality from where the perceptual representations to handle are taken is shown. Finally, it is start on the idea of public action as a lateral axis, which is intertwined with the objective of the investigation, in the urban chromatic intervention and the stakeholder’s participation.

The concepts are analyzed on the one hand from sociology and urban anthropology, the works of Signorelli (1999) are taken into account. Signorelli proposes the study of the city from the conceptions of cognitive-value systems that are developed in urban contexts and that are products of cultural dynamics, such as urban cultural construction processes.

In the same sense, the ideas of Wirth (2011) are analyzed, who explains how the city can be “read” from different configurations that involve urban planning as a way of life and highlights for this the particular characteristics of a city from its physical structure, its social organization system and the set of attitudes and ideas that participate in the collective behavior and symbolic construction of the city.



The proposal of Kevin Lynch (1985) is resumed, who introduces the environmental apprehension theory, the sensitive image and the elements that the image of the city has to be understood. For the study of color and the city, work is approached with a visual-perceptual approach by Jean-Philippe Lenclos (1999) that introduces the concept of “color geography” pointing out that the specificity of the traditional colors built is closely related to environmental, regional differences and, above all, to the use of local building materials.

The most important contribution of Lenclos has been the development of his methodology that was based on the use of different stages and tools, such as observation, material sampling, drawing and watercolors at the place of study, the comparison and systematization of information through the realization of color palettes. With all this, Lenclos generated particular color palettes for the different study sites around the world, which aimed to characterize each area according to their specific colors. (Odetti 2019: 29)

Verónica Zybaczynski’s (2016) work on the rescue of color as an element of identity is also taken, underlining how each color response in the city is a design and that this response is due not only to the justification derived from history and a pre-existing, but from an aim of the faculty of color to resolve the contradictions dictated by the transformations of the city, that involve both the historical urban weave and the suburbs.

Finally, based on the theory, the elements that constitute the objectives of sustainable development to integrate it into the design process, specifically with social participation in the development and integration of Stakeholders.

## **Methodology**

The research design corresponds to a qualitative study, with an interpretative and action research perspective, which takes into account the analysis of the meanings attributed by the research subjects to the case study, it seeks to interpret the construction of senses through the application of the various instruments selected.

The general objective of the project is to make a proposal for the design and improvement the urban image for university campus contexts, in Puerto Vallarta, Jalisco. The specific objectives included in this work are: a) Analyzing the elements that constitute the urban image of the university campuses context. b) Characterizing the urban image elements of the university campus environment. c) Integrating the stakeholders in the conceptualization of the design proposal and improvement of the urban image. d) Proposing the chromatic intervention for urban image in university campus contexts.

The selected techniques and tools are: documentary and field research, action research, cartographic analysis, analysis of qualitative variables with geographic information systems, participatory workshops, and in-depth interviews.

The selected instruments are: field file, SWOT analysis, urban image drawings, geographic information system, interview formats, workshop format, and questionnaire format.

## **RESULTS AND DISCUSSION**

The different phases in which the project was divided, allowed to obtain information in a first stage of diagnosis on the area to intervene, the infrastructure and urban image conditions presented by

the selected study area, the particular characteristics of the community, identifying the stakeholders, from the participation of neighbors, merchants, social, cultural and religious actors, to the presence of government authorities and educational establishments that constitute the context.

The university campus from where the following work is proposed is located in an area considered urban borders for a city that has high rates of social inequality and urban segmentation. The Instituto Tecnológico Mario Molina, Puerto Vallarta campus, is located within the sub district 4 C, in the neighborhood Lomas del Coapinole (Figures 1 and 2).



Figure 1:  
Location map, Coapinole neighborhood,  
Puerto Vallarta.



Figure 2:  
El Coapinole neighborhood facades.  
Puerto Vallarta.

The proposal of chromatic intervention for these contexts of university campus in Puerto Vallarta, supposes an impact and solution to variables that affect from the social order, the sustainability of marginalized environments, the relationship with the productive sectors that will benefit and the generation of scientific and technological knowledge that characterize and serve as a basis for all actions that impact development and the improvement in equity situations for the Puerto Vallarta urban border areas. In this sense, the leading role of university institutions as detonators of social development in their contexts is the most relevant aspect in the project impact.

For the diagnosis in the neighborhood, its main roads were selected for the color registration. The registration of these palettes located in the study area was made from the Color Sorting System, Natural Color System (Figure 3).



Figure 3: Observation and chromatic record of the Coapinole neighborhood. Puerto Vallarta.

Once the chromatic survey was carried out, the study area was delimited four blocks for the intervention proposal that stood out in the area for its location, urban infrastructure and the presence of active economic units that will facilitate in the future the participation of stakeholders in the final phase of the project. In addition, a scale of chromatic synthesis of the selected area was developed, to work later in participatory workshops (Figure 4).

For the next step, it was necessary to identify the neighbors and the stakeholders, with whom the intervention is planned. For this, study sheets were made and applied, with the drawing and location of each of the properties to be involved in the selected polygon (Figure 5).



Figure 4: Synthetic color palette for Coapinole.

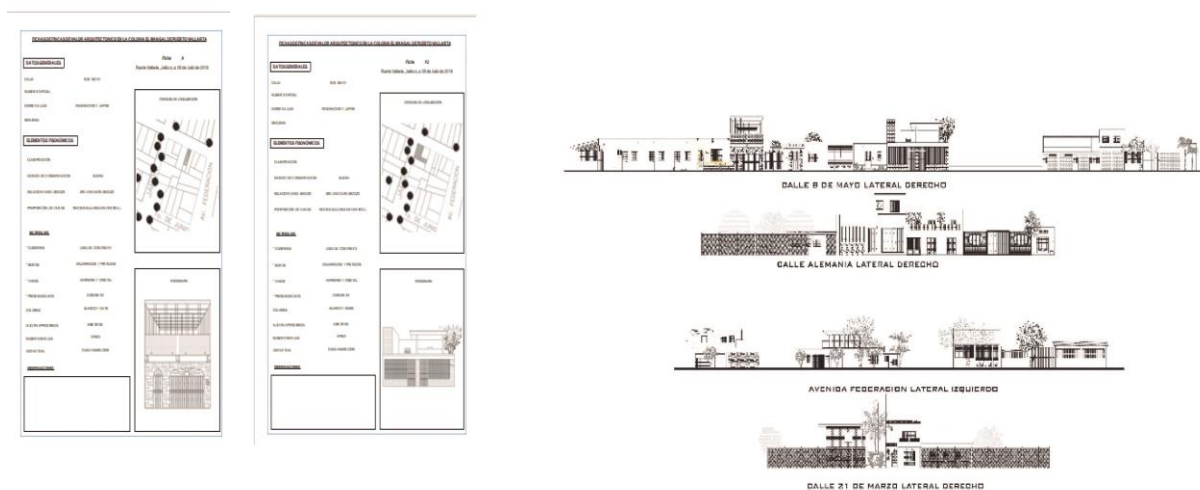

Figure 5: Field and sketches of the properties selected for the intervention.

At the time of the present publication, meetings are being developed to generate the participatory workshops with which the design and development of the chromatic intervention will be worked with the neighbors and the stakeholders. Three workshops were proposed for this.

In the first, participants are invited to work with images that allow them to express their needs and visualize the space they inhabit. They are used as sources, photographs, icons and words that are inserted in the cartography of the place. Including photographs as work material allows participants to carefully observe their surroundings and be able to detect their own needs and wishes.

The second workshop will invite the participants to tell and rescue stories of the town and their life in it, their journeys and daily experiences in the living space they share. The idea of expressing in urban words or small texts their urban experiences has the objective of making visible all those aspects of their context that they wish to preserve or modify.

The third workshop concludes with the proposal of chromatic intervention, the participants are presented with a color palette, taken from the diagnostic strips made and invited to select those colors with which they would like to intervene their facades and their urban context. In this workshop, you can also make a small conversation about sensitization towards color, which includes small pictorial experiences of play and combination of pigments. From there, the process of community self-management will begin to make the chromatic intervention a reality, where the design of the intervention, the necessary materials and the dates to specify it are planned and scheduled. The workshops will be guided by the teachers in charge of the project, accompanied by students of the ITMM Architecture degree, and the representation of authorities that commit to follow up and conclude all the necessary procedures for the management of the resources and the premises that they derive from collective practice.

## CONCLUSION

The work of carrying out a chromatic intervention as part of an urban image design improvement project in the university campus contexts located on the city borders, gives special emphasis on the role of color, as a leading element of the urban image. This means that color can build the visual memory of an urban area, as well as the vivid image of the city.

By including in the methodology of this project the participatory space in the planning, design and self-management of the intervention, the experiences of its inhabitants are involved and how they interact and coexist with the colors. The possibility of choosing a color palette to intervene their living space generates the opportunity to make visible their streets, their squares, their constructions, the natural context, their facades and their textures.

In the methodology of participatory workshops, the fact of working in a playful way with images, stories and color, offers the opportunity to understand and experience these visual and narrative elements as participants in the configuration of the identity of an area, and in the urban cultural construction of it.

The results, coming from the study and chromatic intervention, at the time of the presentation of this work show the need to link public universities with the contexts in which they are installed to offer and generate improvements with the active participation of the inhabitants and users as products of a joint and collaborative action between the university and the different social actors that participate in the community.

## REFERENCES

- Lenclos, J.-P., and D. Lenclos. 1999. *Couleurs du monde: géographie de la couleur*. Antony: Éditions du Moniteur. English translation by G. P. Bruhn, *Colors of the world: the geography of color*. New York: W. W. Norton & Company.
- Lynch, K. 1985. *La imagen de la ciudad*. Mexico: Gustavo Gili.
- Odetti, J. V. 2019. *Los colores de Puerto Vallarta, en la construcción cultural urbana de una ciudad turística: 1990-2016*. Buenos Aires: Universidad de Palermo, doctoral thesis.
- Signorelli, A. 1999. *Antropología urbana*. Mexico: Anthropos.
- Wirth, L. 2011. Leer la ciudad. Ensayos de antropología urbana. El urbanismo como forma de vida. *Revista de Estudios Sociales*, 110-115.
- Zybaczynski, V. 2016. [Colour studies] Re:placing colours. Evaluation of the chromatic interventions on the blocks of flats in Bucharest, Romania. In: *AIC 2016 Interim Meeting "Color in Urban Life: Images, Objects and Spaces"*, *Book of Proceedings*, Santiago de Chile, 18-22 October 2016, I. Calvo Ivanovic, ed. Santiago de Chile: Asociación Chilena del Color, 39-43.

# The extraction and application of regional features of urban colors: On China's urban color planning strategy in the context of globalization

Hongyu Guo

School of Architecture and Urban Planning, Guangzhou University, Guangdong, China  
guohongyu\_2000@163.com

## ABSTRACT

This paper discusses the decisive influence of natural environment and cultural environment on urban colors through studies of several urban color planning projects directed by the author. Based on these cases, it also elaborates on the extraction of urban color system with regional attributes through urban color research, chromatographic analysis and color image analysis to work out urban color planning strategies for the construction of urban color environment. The paper considers these approaches an ideal goal for China's urban color planning in the trend of global convergence, and a necessary way to conserve local color language and create a world of diverse colors each with its own individual beauty against the backdrop of global cultures.

**Keywords:** *regional features of urban colors, cultural environment, natural environment, urban color planning*

## THE VALUE OF REGIONAL URBAN COLOR FEATURES IN THE CONTEXT OF GLOBALIZATION

According to *La géographie de la couleur*, i.e., color geography, the color palette of a region or city, which is jointly defined by its natural geography and cultural environment, exhibits regional expression, thus establishing respective identity of urban colors. Therefore, regional genes and identities of urban colors serve as the most indigenous and historical elements of urban features and constitute a major basis for the formation of urban features.

In the waves of globalization, with increasingly convenient and frequent regional exchanges of information and materials, our building technologies and materials have become much more internationalized. With the introduction of internationally popular new building materials and architectural styles, building materials and construction technologies become more detached from regional environment, hence significantly reduced applications of local materials and practices and gradually fading regional features of urban architectural colors. This results in a worrisome urban color environment with prevailing similarity and weakening identity. Urban colors, which are

supposed as the first presence of a city, turn out to be the last defense of urban features. For this reason, the top priority of urban color research and practices in China at present is to study and explore regional features of urban colors and establish their very own color system for cities in various regions. An impressive urban colors image should thoroughly describe the local environment, naturally reflect the intrinsic cultures, and exhibit a presence naturally developed by the environment, instead of being a forceful implantation of something foreign.

From the perspective of color geography, this paper categorizes regional attributes of urban colors based on natural geographical and cultural zoning. Specifically, it explores the origin and analyzes regional attributes of urban colors of a city based on its natural geological location and cultural context. Through various means, in particular color research, chromatographic analysis, and color image analysis, color palette of the natural and cultural environment is extracted to analyze urban color features shaped in the typical natural and cultural environment.

In the following parts, this paper, by studying urban color planning projects in Jinan of Shandong province, Nanchang of Jiangxi province, and Suzhou and Wuxi of Jiangsu province, discusses the value of regional features in shaping up urban color image.

## **THE EXTRACTION AND APPLICATION OF COLOR FEATURES OF URBAN NATURAL ENVIRONMENT**

The natural environment, as a factor that still contains some local features against the backdrop of globalization, provides requisite conditions for the formation of unique urban colors. Soil, plants, sunlight, temperature and humidity, haze, etc. of the natural environment which jointly constitute the basic color of a city, directly affect the citizen's preference for color brightness and saturation and even the selection of hues. The resulting physiological perception of colors in turn serves as a basis for color psychology. Therefore, careful extraction and application of color genes of the natural environment is a major means to establish regional urban color image.

Soil color, among all, can reveal substantial information about the local environment, and pinpoint the climate zone, temperature and humidity, phytoclimatic zone and altitude of the region. Careful analysis of the Earth's color and basic soil color can provide a basis for the identification of the intrinsic genes of regional urban colors and the extraction of regional urban color system, thus providing a major means to establish an urban color image featuring "one region with one specific color". Therefore, in urban color planning for more than 16 Chinese cities, we generally started from the study of soil colors, not only collecting soil samples, extracting soil color palette, but also analyzing potential information about the natural environment, so as to find local color genes for the recommended urban color system.

In the author's urban color planning for three key areas of Jinan, Shandong province, we searched the natural genes of Jinan's urban colors through careful analysis of the city's soil and rock colors. In Jinan, where brown and cinnamon soils are densely distributed, cinnamon soil takes up the largest proportion, accounting for 74.1% of the total. Therefore, the overall soil color in Jinan is brown, a solemn tone for the city, which also defines the basic color of plants and seasons in this region. Based on in-depth study of the city's soil colors, comprehensive analysis of rocks, plants, climate and other natural environmental factors, and the extraction of corresponding color spectrums, we have reached a series of conclusions. First, the natural environment in Jinan, which is under moderate insolation, is dominated by medium-long wave colors such as Y and GY of medium-high brightness. Second, the seasonal colors of Jinan vary significantly. Third, the range of color hues of plants and flowers in the city is relatively narrow, involving a rich abundance of plants in green-yellow (GY) and green (G) of

low brightness, a great variety of flowers in red (R) and red-purple (RP) of medium brightness, and a few flowers in bright yellow-red (YR). As a result, the natural environmental colors of Jinan appear sullen, heavy, and plain (Figure 1).



Figure 1: Color palette of natural environment of Jinan (from color planning for Beihu area of Jinan).

In addition to soil, plants etc., daylight also significantly affects people’s perception and choice of urban colors. In urban color planning for three key areas of Jinan, we analyzed light environment through scientific measurement based on data from the weather station since 2001 and MICAPS-processed physical data statistics, and discovered that visual barriers in Jinan and surrounding regions mainly consisted of fog (63%), smaze (smog and maze) (28%), with fog accounting for the biggest proportion. Though insolation in Jinan remains at a moderate level in China, the light environment dominated by radiation fog leads to low perceptibility of urban colors. Moreover, due to poor natural ventilation, much dust in the atmosphere, serious air pollution, drought and less rainfall, dust and particles in the air scatter and weaken much daylight, thus lowering the shadow contrast and brightness of urban color samples, resulting in a blurring blue-gray tone of low saturation in the entire urban light environment. In such light environment, light climate impact of cold colors are more obvious than that of the neutral warm colors.

For this reason, in urban color planning for three key areas of Jinan, Shandong province, based on the analysis of soil environment and light climate impact on urban colors, we extracted and incorporated local soil colors of warm brown and yellow-brown into the base color of the recommended palette. To reduce blue-gray tone caused by radiation fog that reduces the perceptibility of urban colors, we incorporated cold cyan of medium-high brightness as a complementary color to adapt to the local light environment, forming a recommended region-specific urban color system featuring “brown soil under warm sunshine, clear water reflecting white clouds in the sky”. The recommended urban color system includes four major tones, i.e., bright sunshine color, warm brown soil color, elegant green-gray color, heavy and light blue-black colors. On this basis, we provided overall color planning guidelines for various areas (Figure 2) and key plots. In urban color design for key zones, we highlighted the factor of distance for analysis of light climate effect, and



developed color design of appropriate perceptibility in consideration of building height and volume (Figure 3). The project won the 7th China Color Grand Award for its scientific extraction of color genes from the natural and cultural environment and consequential color design.

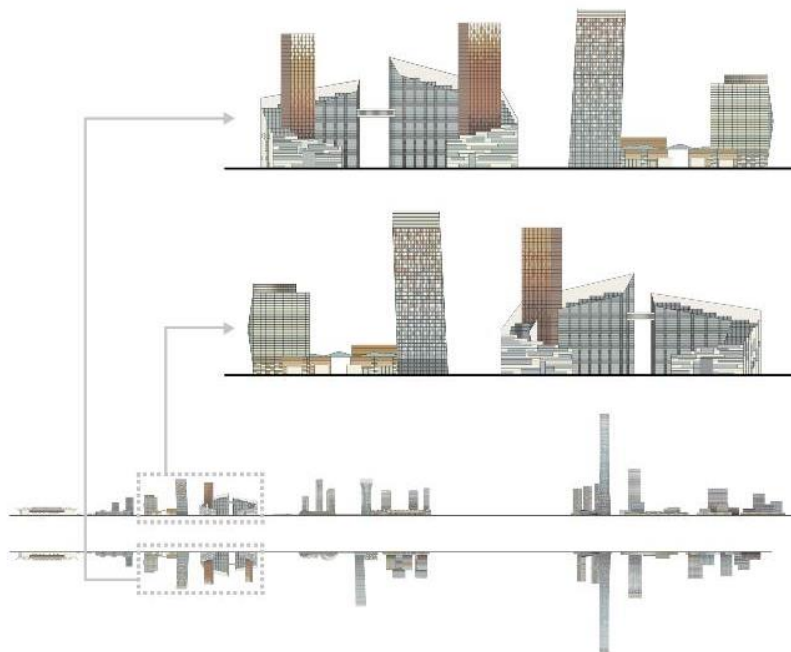

Figure 2: Urban color design guidelines for key plots of Jinan (from urban color planning for olympic sports center area of Jinan).

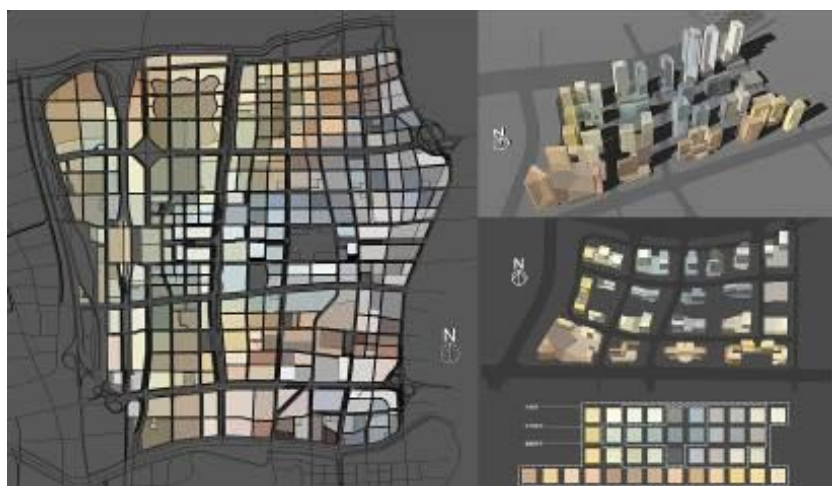

Figure 3: Overall urban color image and key areas guidelines of Jinan (from color planning for west station area of Jinan).

After that, we replicated the application of sunlight analysis technology in urban color planning for Nanchang. By simulating solar trajectory and intensity in typical seasons and analyzing the regional light climate features of the city, we proposed guidelines for architectural color design that could realize good visibility and rhythmic colors along the riverfront (Figure 4). The project won the 9th China Color Grand Award for its urban color system and color design adaptable to the local light environment.

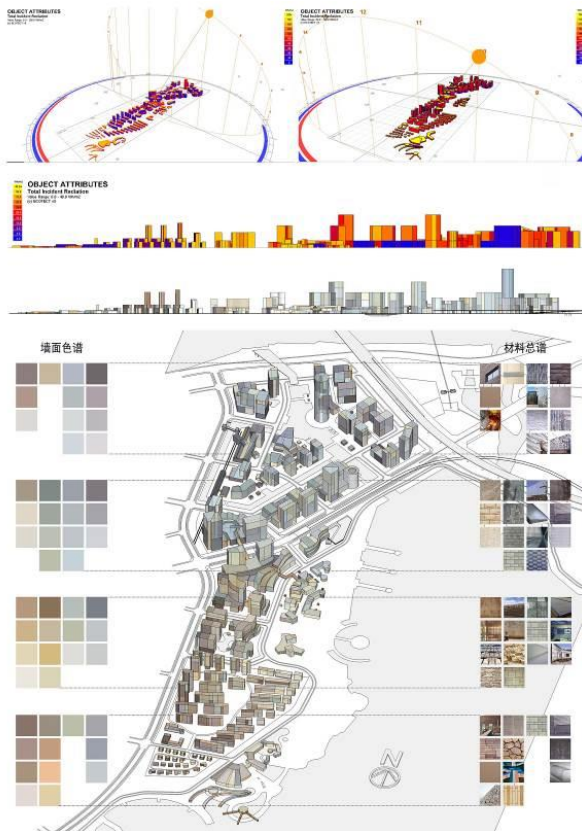

Figure 4: Color design of good visibility for riverfront buildings in Nanchang (from urban color planning for Nanchang).

## THE EXTRACTION AND APPLICATION OF COLOR FEATURES OF URBAN CULTURAL ENVIRONMENT

If natural environmental colors can differentiate between regions, cultural environmental colors serve to distinguish between populations and their homelands. The colors of cultural environment shape the cultural identity of regional urban color features and speak a language that delivers unique urban culture.

Jiangnan region, which is situated in the southeastern part of China, is well known for ancient literati, poetry and painting. Its distinctive cultural features lie in the literati's pursuit of a poetic life and their aspiration for spiritual freedom, so its cultural environment features the color tones of black, white and gray. Ancient literati in Jiangnan region express their lofty aspiration through the contrast between black, white and gray, and their pure morality through achromatic colors, demonstrating a cultural symbol of purity and freedom both physically and mentally. The urban color planning projects directed by the author in Suzhou, Wuxi, Shaoxing and Yangzhou, influenced by Jiangnan culture, are all identified culturally by black, white and gray color tones. In these projects, through urban color study and analysis, we extracted the color palette comprising black, white and gray of the traditional cultural environment in these regions, and incorporated it into the color environment of modern Jiangnan cities to establish a regional urban color image with rich traditional cultural connotations of Jiangnan region.

In urban color planning for Suzhou, after analyzing the historical culture and traditional color context of the city, we suggested that urban colors of Suzhou should not only showcase the typical colors tones of black, white and gray, but also highlight the application of white color that was more favored by ancient literati in Suzhou to express their lofty ambitions. This identity of urban colors as a result of its cultural environment significantly differentiates Suzhou from other cities in Jiangnan

regions such as Wuxi, Shaoxing and Yangzhou. Therefore, we used elegant and plain near-white colors, including yellow (Y), yellow-red (YR) and red (R) of high brightness and low purity, as basic colors, and ink colors including blue-purple (BP), blue (B) and N series achromatic colors of low purity and low brightness as complementary colors. In this way, we established the recommended urban color system and overall urban color image (Figure 5) interpreting the cultural meaning of “a vivid freehand expression of Jiangnan imagery in thick ink and light colors”, thus demonstrating the traditional urban cultural connotations of Suzhou. For example, in the urban color design of Guanqian and Pingjiang historical blocks of the ancient city, we adopt the recommended urban color system for the ancient city, in particular the then trendy color of white, to present an elegant and refined urban color image for the ancient city of Suzhou.



Figure 5: Guidelines for urban color image of Suzhou and color model of Guanqian/Pingjiang historical block (from urban color planning for Suzhou).

Wuxi, also in Jiangnan region, tends to favor gray among the shared color palette of black, white and gray in Jiangnan region. As the cradle of modern industrial and commercial economy in China, Wuxi features pragmatic and flexible business culture, gentle and kind business custom, so instead of strong contrast of black and white, it favors the inclusiveness and richness of gray. The gray tone in Wuxi's urban colors, which excludes almost all N series of achromatic gray, mostly includes red-purple (RP) and red (R) of low purity and medium-low brightness, as well as chromatic gray such as yellow (Y), yellow-red (YR) and blue-purple (BP) of medium-low purity, featuring a rich variety of colorful medium gray colors.

In urban color planning for Xidong new town business district of Wuxi, we studied and extracted the recommended urban color system by means of color derivation of the traditional cultural environment and complementation of contrast colors. For example, we adjusted the joyous red (R) and yellow-red (YR) in traditional festivals to historical crimson of low purity and medium-high brightness, and the blue-purple (BP) of blue printed cloth to more poetic smoky purple-gray of medium-high brightness and low purity. Moreover, we extracted the dark gray color of gray bricks and tiles in Wuxi's traditional housing, the green-gray color of Taihu stones, and the white color of pearls in Taihu lake. That enabled us to compose a recommended urban color system featuring “crimson of classical elegance, smoky purple of Jiangnan region, ink colors of varied shades, and charming landscape” for Wuxi Xidong new town (Figure 6). Consequently, we shaped up a color image dominated by chromatic gray with rich variety of hues, and applied the recommended color palette in the color design of key zones to showcase Wuxi's cultural tradition and features.

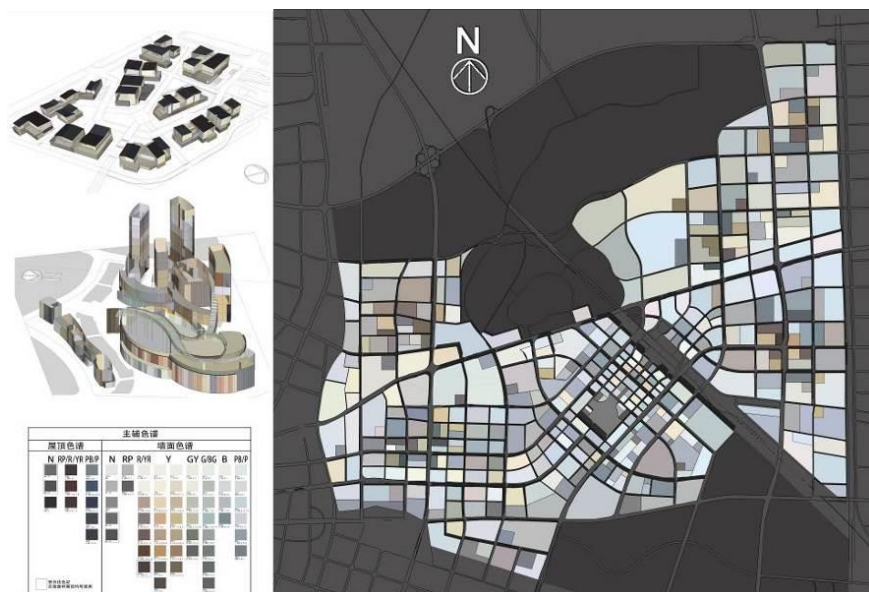

Figure 6: Overall urban color image and key plots color design for Xidong new town, Wuxi (from urban color planning for Xidong new town business district of Wuxi).

## CONCLUSION

In conclusion, this paper intends to establish recommended regional urban color system from the perspective of color geography. Through the application of recommended palette and color planning guidelines, it also aims to shape up unique urban color image, and, with the expression of colors, showcase urban cultures and features to counteract the trend of convergence as a result of globalization. This is exactly the significance of the extraction and application of regional urban color features in the context of globalization.

## ACKNOWLEDGEMENTS

This paper is funded by the Building Energy Conservation and Technology Division, Ministry of Housing and Urban-Rural Development, and 2017 Open Project of Beijing University of Civil Engineering and Architecture *Research on Climate Adaptive Color Design for Urban Space* (UDC2017010612).

# Color and heritage: analysis of the evolution of the methodology used in Italian color plans

Vanessa Peres Martins\*, Natalia Naoumova

Federal University of Pelotas (UFPEL), Pelotas, RS, Brazil

\* vanessa\_peresmartins@yahoo.com.br

## ABSTRACT

This article aims to analyze the evolution of the methodology used in the elaboration of Italian color plans, which are a reference when it comes to color planning, and applicability of this methodology in historical areas of Brazilian cities. In this study, the understanding and reflection regarding color planning are carried out through bibliographical research. We compare the first color plans of Turin, Italy —the *Piano regolatore del colore*, by Giovanni Brino (1978), and the *Progetto-Colore*, by Germano Tagliasacchi (1985)— and more recent color plans for the Italian cities of the province of Latina (2006), focusing on the following aspects: (i) color plan objectives, (ii) methodology, (iii) results and (iv) criticism.

**Keywords:** *color plans, chromatic methodology, historical colors, urban polychromy*

## INTRODUCTION

The colors of buildings express and allow us to identify the chromatic tradition of a place. Therefore, interventions in buildings in historical areas should consider both formal aspects and colors, to improve perception of the urban landscape and preserve the chromatic identity of the place. Understanding that cities are in constant renewal and historical areas are also subject to processes of transformation, it is possible to observe that the use of inappropriate colors for painting the façades of buildings with historical and cultural interest contributes to the disruption of the identity of these architectures. To prevent this, some color control must be proposed, through chromatic planning.

Color plans are often used in European countries, for preservation and appreciation of urban landscapes, especially in historical areas. However, even in these areas, it is important to highlight that the chromatic planning can be carried out with different goals, degrees of coverage and urban scale. Amongst the many purposes of color plans, it is possible to mention: the transformation of the visual perception of urban shape, as in the Zamosckvorechie area and in Arbat street in Moscow (Efimov 1992); the harmonization of colors of contemporary buildings and urban and natural

landscapes, based on local polychromy, as the ones for European cities carried out by Lenclos (1999) and Lancaster (1996).

The chromatic proposals carried out have confirmed the idea that in interventions, the buildings' colors cannot be approached in an isolated way, with no regard for urban or stylistic contexts; and several morphological factors must be considered together and accordingly with specific planning goals. Thus, in order to achieve the different goals that each chromatic plan can have, different methodologies can be elaborated. Some of these methodologies can be based on historical analysis of documents, physical surveys on buildings, quantitative and qualitative analysis of urban areas and also, evaluation about the perceptions of local users.

A way of controlling colors in the city may be the use of a tool called *color plan*. Usually, these plans aim at protecting and regulating the cities' historical colors. This way, they contribute for conservation and recovering of the place's identity. Color plans can be used as a tool for urban planning, when integrated to the cities' urbanistic plans, or as a guide, with instructions regarding chromatic interventions in façades. The methodology used for elaborating color plans is not closed nor stagnate. It evolves and modifies along time, incorporating different stages and complex components.

So, this article aims to analyze the evolution of the methodology used for elaborating Italian color plans, which are a reference in what concerns color planning, as well as the applicability of such methodology in historical areas of Brazilian cities.

### **Color plan: concept and elements**

A plan usually begins from the definition of its goal; followed by the elaboration of the methodology to be adopted; researches, both historical-documental and *in loco*; analysis and systematization of the obtained information; elaboration of graphic materials, such as color palettes, chromatic combinations; elaboration of the plan and control.

The general methodology of a successful color plan, according to Aguiar (2005: 374), would be composed of: research and analysis of useful information, surveys to characterize the current situation, determination of the color archeology, synthesis of the information obtained, transcription of these information to the plan-project, definitions about the forms of practical action and plan control.

In what concerns the form of action, Raimondo (1987: 53) states that color plans may be classified into three main types: *prince's plan*, *philologist plan* and *citizens plan*. Putting it into general terms, the first type is an imposed plan, which may be ordered from prestigious artists or well-known architects, or establish an image of the city that must be achieved through the plan. The second type, also imposed, consists in reconstruction of the color, based on the comparison of different documentation sources, searching that the individual architecture respects the collective construction, the image of the ensemble. The third kind, the citizens plan, is not imposed, as it calls for the population's participation, within given technical limits.

Regarding elements, color plans have several groups of documents that approach several stages through which chromatic planning in historical areas respond, such as: historical-critical, bureaucratic-administrative and operational. Besides that, the color plan itself, as a tool of orientation and control, is composed of written documents and drawings that allow its execution.

## Methodology

In this study, the understanding and reflection regarding color planning are carried out through bibliographical research. We compare the first color plans of Turin, Italy —the *Piano regolatore del colore*, by Giovanni Brino (1978), and the *Progetto-Colore*, by Germano Tagliacchi (1985)— and more recent color plans for the Italian cities of the province of Latina (2006), focusing on the following aspects: (i) color plan objectives, (ii) methodology, (iii) results and (iv) criticism. The choice for the Italian color plans for this analysis is due to the fact that they are pioneers in developing a methodology, which influenced both practical experiences in other countries and further research in this field.

## RESULTS AND DISCUSSION

### Characterization of the plans

Although the three plans analyzed are developed in historical areas, it is possible to identify that each one presents peculiarities in what concerns the scale of action, goals, coverage and intervention area.

The scale of action of the plans is quite different. It went from the city scale to the province scale. The first two plans analyzed regard one single city (Turin), whereas the color plan for the Italian cities of the province of Latina brings preliminary guidelines for chromatic and restoration interventions for the historical centers of six cities of the province.

Both Turin plans came from a need of the public administration to regulate intervention and maintenance of façades in historical areas. On the other hand, the province of Latina plan came from a possibility of public investment in restoration and rehabilitation of historical centers of cities in the region, through policies of urban requalification and stimulus to tourism.

The plan developed by Giovanni Brino, *Piano regolatore del colore* (1978), searched to establish a code of conduct that oriented intervention and maintenance in façades in the historical areas of Turin (Muratore 2010). The city's painting went through a strong mischaracterization, during the international expo *Italia 61*, in which the city was systematically painted with *giallo Torino* (Aguiar 2005). Brino's goal was to reestablish original colors in the historical area, through the elaboration of a plan based in documents found in the public administration files.

The elaboration of the *Progetto-Colore* proposed by Tagliacchi, in 1985, was less attached to historical-philological aspects and more related to the role of colors in the definition of urban spaces, historical contexts and morphological characteristics of façades. Its goals were the appreciation, conservation and custody of built heritage, purposes which turned it into a more conservative plan (Muratore 2010).

The third plan analyzed, color plan for the Italian cities of the province of Latina, aimed at achieving a better environmental quality for the city and especially for historical centers. This plan, in addition to presenting preliminary guidelines for chromatic interventions, has also brought guidelines for restoration interventions in buildings in historical centers. It considered not only remarkable buildings, but also minor accompanying architecture and their urban context.

The methodological base for the first Turin plan was essentially in documents from files found during researches in the city. These documents belonged to a program carried out in the 18<sup>th</sup> and

19<sup>th</sup> centuries, by the architects of the *Consiglio degli Edili* (1774-1841) (Muratore 2010). From these documents, it was possible to identify typological proposals for colors of main streets and squares and of several buildings, in addition to original recipes of the limewash paint, published in manuals at the time (Brino 1984).

The second Turin plan was also based on documents found in the archive, however, it has significantly broadened its coverage, as it was not limited to analyze these documents, but also started to look for physical evidence, with more detailed prospections and solid choices, focusing in restoring particular histories of each building and their contribution to urban context.

The intervention areas of the plans were also different, with focus turning from the building and the street, fixed at a historical period, like in the Brino plan; to the building in the city's historical context, considering the evolution of cities and their changing dynamics, with the Tagliasacchi plan; and finally arriving at the Latina plan, with an action developed in the complex urban scene, analyzing different kinds of values, such as: degree of visual mischaracterization and environments formed by buildings of several forms and periods, together with the cities' specific contexts.

Brino's plan was developed into the traditional limits of the consolidated city and brought orientation regarding the main ways and squares, working to reestablish the city's "original colors". It presented three main stages: registry of the chromatic preexistences (from surveys in the archive); treatment of this information, definition of the main chromatic typologies and creation of color palettes; and elaboration of the color plan and its regulation (Aguiar 2005).

Although Tagliasacchi worked in the same city as Brino (Turin), the methodology of his plan was developed more dynamically, with the creation of two parallel areas of action: direction and control activities; and investigation activities. The first one was related to the process of research, project, execution and inspection of the works, whereas the second one was related to the analysis of information about the buildings in Turin's urban context, registering these information in a historical-critical reference board, integrating results of the research and project activities, expanding the knowledge about the role of color in the history of Turin's architecture and urban environment. In the Tagliasacchi plan, color was not considered as something static, but as dynamic, following the evolution of the city and its artistic moods. Thus, there was no reduction of the cultural meaning of innovation, transgression and ruptures in the buildings' paintings (Tagliasacchi 1992, Aguilar 2005).

The color plan of the province of Latina searched, through its methodology, to understand the urban scene, or so to say, the buildings of several periods, together with the cities' contexts. In addition to historical characteristics of color, techniques, traditional paints and materials, it also approached the city's morphological-perceptive aspects. Its methodology can be divided into four stages: the first one is the elaboration of a structure for the general methodology, which shall point out which methodology must be adopted for a more efficient answer to the requirements of the color plan goals in each city. The second stage is the historical research and preliminary analysis of typo-morphological characteristics of urban tissue, urban perceptive structures and description of construction materials and techniques. The third one is related to the study of color and materials, in which there is an analysis of traditional and modern materials, the relation between type of building and color, the identification of materials, according to the place construction traditions and the constructions techniques used and to the buildings' functions. Finally, the fourth stage is the plan articulation, in which the plan guidelines and graphic elements are elaborated.

In what concerns typology, the color plans analyzed approximate to the classification by Raimondo (1987). Giovanni Brino's *Piano regolatore del colore* (1978) is a prince plan, for it was



requested by the public administration and its elaboration is attached to an image of the city as found in an archive, which ends up homogenizing the buildings' paintings, with no regard for the historical testimony of the city's architecture through different periods. The second Turin plan, *Progetto-Colore* by Germano Tagliaschi (1985), as it searched to harmonize different moments of paintings in buildings and their relation to the context in which they are, can be considered as a philologist plan. Finally, the plan for the cities in the province of Latina could be considered as a citizens plan, as it searches for harmony of historical colors and preservation of the landscape, based on documentation, and also allows the population's participation regarding the use of colors, within established technical limits.

In a general way, as results, the color plans analyzed have produced graphic materials and gathered data, such as: color palettes with color standards that represented the range of colors found, charts with color combinations that were most recurrent in surveys, drawings of façades with color proposals. In this sense, it is worth highlighting that the province of Latina color plan resulted, in addition to the materials mentioned above, into a value chart (indicating levels of degradation of buildings and where priority interventions are needed) and a values classification system (which contributes for the indication of areas of more urgent need of intervention, defining a graduation of scheduled interventions).

### **The evolution of the methodology used in the elaboration of Italian color plans**

It was possible to observe that there was significant historical-critical and technical-methodological evolution in the elaboration of color plans. This advancement comes with the *Progetto-Colore* by Germano Tagliaschi (1985), which introduced a new perspective in color plans: to plan and to design with new historical-critical awareness (Aguiar 2005), in contrast to the plan proposed by Brino, which searched to reestablish the polychromy of a specific given period, disregarding the evolution of each building along time and their contribution to the urban context. In what concerns technical-methodological issues, the methodology has started to consider morphological aspects of the city and to include restoration indications for buildings in imminent degradation.

The evolution of the plans analyzed also happened in what concerns multidisciplinary staffs, which elaborate them, their scale of action, the area of intervention and its coverage. The staff that elaborates the plan becomes multidisciplinary. In the case of the color plan for the Italian cities of the province of Latina, its elaboration happens from a study carried out by architect Luigi Piemontese, together with a technical-professional team formed by architects, historians and tourism professionals (Piemontese 2006). The scale of action went from city to region, proposing guidelines for an ensemble of cities which, depending on their characteristics, can opt for a more detailed color plan. The area of intervention of the plans has also changed, with focus turning from the building and the street to the complex urban scene. The plans coverage has evolved too, from an almost-exclusive analysis of historical documentation in the first one, they start to consider the documentation together with physical analysis of buildings and contribution of their colors to the urban context and finally, in the third plan, in addition to approaching the color related to the building and to the street and the contribution of the building to the context, they also considered the morphological-perceptive analysis of the urban environment.

### **Applicability of the color plans methodology in Brazilian historical areas**

The painting of façades, in Brazilian cities, is usually done by the buildings' owners, with no need of prior requests to the public administration. The exception is when chromatic interventions happen in buildings considered as historical heritage, for which one needs to present intervention projects and requests for painting. However, chromatic interventions are usually isolated, in isolated buildings, regardless of the context and the other buildings of the ensemble that composes urban landscape. Also, there is no specific legislation when it comes to the use of colors in historical centers. There are general guidelines, which do not consider the methodological tools studied in the color plans presented in this work.

Among the analyzed plans, we argue that for Brazilian historical centers, the citizens' plan typology would be more appropriate, with a methodology similar to the one used in the Latina plan, because it brings together the work with historical documentation and morphological-perceptive aspects, making it a more complete plan. In addition, considering the relationship of homeowners and façade painting in Brazil, it is important to consider the participation of the population in color planning.

### **CONCLUSION**

Chromatic planning for a historical area is a complex, multidisciplinary task, that involves cultural, theoretical and historical aspects. Color plans for historical areas aim to protect chromatic traditions and the cities' cultural identities. However, a color plan cannot be an intransigent tool that freezes urban images.

From an analysis of the color plans presented, one notices the methodological evolution that occurred from the first Turin color plan, the *Piano regolatore del colore* by Brino (1978), to the more recent province of Latina color plan (2006). The main changes to be highlighted are: the understanding about the contribution of buildings to the urban context; the inclusion of urban morphology and perception of environment issues; and the development of maps and valuation systems, with indications of areas where restoration interventions are more urgent.

The discussion about the methodology adopted in these chromatic plans is relevant because it allows to find out general principles that should be considered when developing an adequate methodology for the use of colors in Brazilian historical areas. Through the analysis of the methodology used in the chromatic plans, it is possible to observe historical-critical and technical-methodological evolution in the elaboration of the color plan, and the need to include formal and morphological aspects of the city in the color plan. Unfortunately, in Brazil, we are still at the beginning of a process of understanding the need for regulation of interventions on the surface layers of historical buildings, for their preservation and conservation, both in aesthetic and technological aspects.

## REFERENCES

- Aguiar, J. 2005. *Cor e cidade histórica: estudos cromáticos e conservação do património*. Porto: Edições FAUP.
- Brino, G. 1984. Il piano del colore di Torino: il problema del controllo delle tinte. *Bollettino d'Arte* 6: 115-116.
- Efimov, A. 1992. The colour of Moscow. In: *The colour of the city*, E. Taverne and C. Wagenaar, eds. Laren: V+K Publishing, 30-55.
- Lancaster, M. 1996. *Colourscape*. London: Academy Editions.
- Lenclos, J.-P., and D. Lenclos. 1999. *Couleurs du monde: géographie de la couleur*. Antony: Éditions du Moniteur. English translation by G. P. Bruhn, *Colors of the world: the geography of color*. New York: W. W. Norton & Company.
- Muratore, O. 2010. *Il colore dell'architettura storica: un tema di restauro*. Florence: Alinea Editrice.
- Piemontese, L. ed. 2006. *Progetto piano del colore: I piani del colore della provincia di Latina*. Rome: Gangemi Editore.
- Raimondo, C. 1987. *I piani del colore. Manuale per la regolamentazione cromatica ambientale*. Rimini: Maggioli Editore.
- Tagliasacchi, G. 1992. Metropolis: the recolouring of the city; reflection and chronicle. In: *The colour of the city*, E. Taverne and C. Wagenaar, eds. Laren: V+K Publishing, 68-83.

## Color ideas. Urban chromatic actions from teaching

**María Marta Mariconde<sup>a\*</sup>, María Inés Girelli<sup>a</sup>, Raúl Darío Suárez<sup>a</sup>,  
Marcelo Balián<sup>a</sup>, Sara Leonor Kenny<sup>a</sup>, Laura Suez<sup>a</sup>, Marcos Barboza<sup>b</sup>,  
Roberto Ferraris<sup>b</sup>, Victoria Ferraris<sup>b</sup>, Beatriz Ojeda<sup>b</sup>**

<sup>a</sup> Universidad Nacional de Córdoba, Facultad de Arquitectura, Urbanismo y Diseño,  
Instituto del Color, Córdoba, Argentina

<sup>b</sup> Universidad Nacional de Córdoba, Facultad de Arquitectura, Urbanismo y Diseño,  
Cátedra de Morfología Urbana, Córdoba, Argentina

\* mmmconde@gmail.com

### ABSTRACT

*Ideas de color* was a student competition whose purpose was to articulate actions between university and society. Specifically, knowledge about color, construction and strengthening of the urban image of the city of Córdoba, Argentina was transferred. Within this framework, a student competition was developed in 2017, stimulating the transfer of extension activities to the city from the teaching practices developed in the degree space of the chair of Urban Morphology, Faculty of Architecture, Town Planning and Design, National University of Córdoba. From the theme of color in the city, the intention was to develop the application of urban color learning practices, to a real design situation. Therefore, from the visit to the study sector, the construction of color palettes was carried out, and its subsequent application by means of a chromatic arrangement in the composition of the facade of the old Children's Hospital building.

**Keywords:** *urban color, teaching, urban morphology*

### INTRODUCTION

From a morphological approach, it is up to the city operators to study those instruments that contribute to the construction of the identity of the urban image, with a social commitment that makes each city unique, memorable and with insertion into the local framework and regional. In this framework, color is an essential tool for the revaluation of urban areas. Verify and maintain its performance, build, accentuate, or materialize the image, contribute to achieve the expression of a legible urban scenario.

The Faculty of Architecture, Urbanism and Design of the National University of Córdoba, is one of the advisory institutions for decision-making in different areas of urban action.

In this institutional framework, from the Institute of Color, and the chair of Urban Morphology, research, teaching and extension activities developed since 1996, in the field of urban morphology focused on the language of color (see Ávila and Polo 1996). This task is part of actions in the public sphere from the university to the community, to provide knowledge about colors, construction, and strengthening of the image of the city of Córdoba.

The work presented, recounts the experience of a student competition conducted in 2017, allowing the transfer in extension actions to the city from teaching, in the degree practices of the chair. Based on the study of urban color, it was proposed to transfer learning practices to a specific design situation in the city. The exercise carried out had different steps through which the selection of a color arrangement was applied, which was used after some adjustments. It made by professionals of the Color Institute, in the composition of the facade of the old Children's Hospital building, the current headquarters of the offices of SENAF, Ministry of Justice and Human Rights of the Province of Córdoba.

The tasks performed are framed in a collaboration agreement signed within the extension activities related to the Faculty of Architecture, Urban Planning and Design, and the Ministry of Justice of the Province of Córdoba, to generate a positive synergy. This agreement represents a real incentive for learning issues inherent in the construction of the image of the city, and the improvement of educational quality in the training process for students and teachers of the chair.

## **METHODOLOGY OF THE COMPETITION**

The competition was raised as a pedagogical experience, based on work methodology developed in the framework of the articulation between the institution of higher education, including teachers of the subject and Color Institute, and the provincial management body, the Ministry of Justice of the Province of Córdoba, in the figure of the responsible technician entrusted to act as a reference.

From the organizing team, the intention was to recreate the mechanics of a real competition of ideas, in the manner of the professional practice of urban operators that approach the urban image from a morphological approach. For this reason, the team designed the test tools, such as regulations, bases, the consultation instances, and the jury was appointed to evaluate the presentations. It was made up of four members: two teachers from the Morphology III of Faculty of Architecture, a representative of the Color Institute, and a representative from the Ministry of Justice and Human Rights of the Province of Córdoba.

Students interested in participating should register in a group of two or three people, through a web form. Likewise, the activity to be carried out would integrate their learning and practice about urban color, within the program of the subject. It would be a special learning instance compare to the rest of the students of the regular course.

In total, approximately 300 students from different courses of the subject participated.

In the presentation of the work to be developed, it presented the following objectives:

- To stimulate the transfer in actions of extension towards the city, of the teaching practices developed in the degree space of the chair of Morphology III, career of Architecture, FAUD, UNC.
- Promote the interest and motivation of the students of the chair, through a practice of transferring content about Urban Color, through a proposal of ideas about the building of the former Children's Hospital in the city of Córdoba, currently the headquarters of dependencies of SENAF, Ministry of Justice and Human Rights of the Province of Córdoba.

- Strengthen the knowledge and instrumentation acquired in the academic program of the chair of Morphology III, FAUD Architecture UNC career about urban morphology, specifically urban color.
- To explore the color from the construction of chromatic ranges by groups of students, to understand the contrasts and the chromatic interactions as a resource of chromatic design of urban exteriors.
- Develop creativity, the ability to work in a team in a design practice on a specific reality.
- To promote the dissemination of the works that, in the jury's opinion, obtain a prize and mention.
- Contribute to increase transfer actions from the university to the community, with interest in teaching practices committed to the city of Córdoba and the province.



Figure 1: The urban façade of the old Children's Hospital building, current headquarters of the dependencies of SENAF, Ministry of Justice and Human Rights of the Province of Córdoba.

## WORKDAYS

The activity was carried out in several days. The first consisted of a visit to the area to intervene, for the reading and perceptual registration of color in the Plaza de los Niños, Corrientes and Tránsito Cáceres de Allende streets. On that occasion, the teachers, together with the groups of participating students, relieved the real situation.

The second meeting was a workshop workday. Different color palettes and chromatic arrangements were exercised for the design of the facade of the building of the former Children's Hospital of the Province of Córdoba.

The guidelines for the construction of color arrangements consisting of a contrasting polychromatic palette between two groups of harmonic tones were raised (Itten 1992). Likewise, criteria for the composition of the urban façade were exposed, based on design premises derived from knowledge and interpretive reading. These criteria of application had to consider partial, total or punctual syntaxes in the typologies of the buildings, according to the morphological interest, the historical value, the situation in the fabric or the activities, among others.

To define the color palette, the students made some decisions such as the definition of value, temperature, and color saturation keys. Having as reference the building to intervene, they had to select the dominant shade or chroma and its distribution in the different areas or surfaces of the facade.

Before the final presentation, consultations were held for the teaching team, which acted as advisors to the contest. The final presentation to be evaluated by the jury consisted of the delivery of the requested graphic pieces. These included: a spreadsheet, with the detail of the color palette developed for application in the composition of the facade arrangement; the premise or criterion that generated the idea of color; the façade intervened chromatically from the technique of coloring with tempera or acrylic, defining the color surfaces; and pedestrian approaches with the verification of the proposed palette.

After the criticism of works selected by the jury, the final presentation of the graphic pieces was made, adjusted in their details as requested. The final presentation format was a Poster for subsequent exposure and dissemination. This panel included a descriptive report specifying the intentions considered in the proposed color design.

Finally, as a way of closing the competition process, a sharing was carried out with an assessment of the result of the activity by the jury, the students and all the actors involved, rewarding the best results. Once the practice finished, it was exposed in the FAUD.



Figure 2: Above, the winner project. Below, different steps of the competence: experiencing color palettes in a workshop, and the exhibition in the Faculty of Architecture, Córdoba, Argentina.

## RESULTS

The winning project presented an interesting arrangement to define the environmental color, based on a combination of warm colors that contrast with the existing facade in the opposite block.

The central idea of the project was to homogenize the color of the facade, maintaining a high-value color or luminosity as a base, and highlighting the moldings or details with low-value tones. The intervention respects and maintains the environmental color detected in the reading of the area, predominantly earthy colors.

The other winning works highlight in their proposals the incorporation of different strategies, equally valuable for the jury. Finally, to close the competition process, an exchange activity was carried out evaluating the results obtained. The jury, the students, and all the actors involved

participated. Subsequently, an exhibition was held at the Faculty of Architecture, Urban Planning and Design.

After all this process carried out in 2017, at the end of 2018 the facade was finally painted respecting the winning color project after the adjustments made by the Color Institute.

### **ACKNOWLEDGEMENTS**

We wish to express our gratitude to the Ministry of Justice and Human Rights of the Province of Córdoba and the Secretary of Science and Technique (SECyT), National University of Córdoba for the economic support to the Institute of Color.

### **REFERENCES**

- Ávila, M. M., and M. R. Polo. 1996. *Color urbano. Indagaciones en ámbitos de la ciudad de Córdoba*. Córdoba, Argentina: Eudecor.
- Itten, J. 1992. *El arte del color*. Mexico: Limusa.



# Color Education



# IACC colour training —IACC Academy Salzburg, Austria

**Edda Mally, Jin Hee Lee**

IACC Academy Salzburg ©, Austria  
eddamally@outlook.com, epleejh@gmail.com

## **ABSTRACT**

The International Association of Colour Consultants/Designers, in short IACC, is one of the oldest colour associations in Europe. Founded in 1956 in Hilversum, The Netherlands, it was established by colour scientists of different fields of knowledge and of many countries, in response to a total lack of trained colour experts. Since the beginning, the IACC has dedicated its full activity to colour education.

**Keywords:** *colour education, colour training, colour consultants, IACC Academy Salzburg*

## **INTRODUCTION**

The first president of the International Association of Colour Consultants/Designers (IACC), Dr. Heinrich Frieling, biologist, psychologist, author and artist of Marquartstein, Germany, was asked to create a training programme for a new type of specialist. Only with colours he should be able to design balanced environments for the wellbeing of humans, supporting their different professions as well as also their recovery and relaxation.

For 28 years as an IACC colour designer I have worked for the association, lecturing and organizing the IACC seminars. Now, as the actual head of the IACC Education Europe, it is with immense pleasure that I present the colour teaching curriculum of the IACC Academy Salzburg ©, Austria, to the AIC Colour conference in Buenos Aires.

Heinrich Frieling presented his first seminar in Salzburg in 1958, in the heart of Europe. So in 2018 we had the great pleasure celebrating our 60th anniversary of foundation, with guests from Canada, Europe, Japan, Korea, the United States and with congratulations of our IACC vice president of South Africa.

The colour training programme is a cycle of 4 seminars held over 2 years, the participants progressing deeper and deeper into an understanding of the medium of colour. The speciality of this colour teaching programme is to introduce the results of scientific research and perception as the base for the practical use of colour. Each seminar lasts 6 or 7 days, each with 8 hours of instruction and practical exercises. The study ends with a verbal examination of all presented subjects and, if

appropriate, a thesis. We are very pleased that these papers are collected and stored in the library of the University of Salzburg.

Seven to nine different experts lecture on various subjects such as physiology, psychology, light, aspects of colour in the internal as well as external environment, and medicine, just to name a few. This helps to develop an understanding of human responses to colour. Other subjects include information on different building materials, their surface, characteristics, colour variations and practical use.

For colour planning, the IACC curriculum does not advocate the use of computers. The two different ways of mixing colours, additive and subtractive, cause serious difficulties. These two worlds are never going to meet: one is light, the other material. This fact has to be respected, when dealing with colour in practice.

The human body is primed to receive various stimuli. Among them is colour. This means that working and living in a monotonous environment is stressful to the body. Research has shown that too strong and saturated colours also create stress. Balanced coloured surroundings have the under used property to diminish stress, especially when there is no connection with nature.

In the Austrian press, a recently published article on the internet stated that more than 75 percent of all illnesses are caused by stress. We, colour consultants, really need to pick up on this perception and create a harmonious colour climate for each type of environment and for any kind of work.

## GENERAL INFORMATION

The IACC Colour Academy starts the 1st seminar with an exercise, which is —in our view— very important for the whole profession: to make the students aware of what they really see, and not to see what they think they know. Analysing some special images and experiencing their own physical reactions help to educate the eye, the mind and the sentiments. The human senses are important for communication with the environment, including nature. What perception of colour design do we get when we test them in practice? What do we discover when observing an environment consciously? And what sensation do we have, when we walk —carefully guided through an environment—, or we taste something with covered eyes.

Colour theory comprises practical experience of using colours, such as systematic colour mixing, primary and secondary property of colours, harmonious and disharmonious colour sequences, colour contrasts, colour and optical weight, and their effect for colour design.



Figure 1:  
Discovering the sense of touch with covered eyes.



Figure 2: Students learn to mix colours systematically and to arrange wooden samples according to the rainbow.

## COLOUR AND MATERIAL

Practical information about colour and material and their importance for colour planning is a unique experience for our students. Each material has colour, even glass! The conscious and careful choice of materials and their specific colours is essential for a balanced colour climate indoors as well as outdoors. One of the exercises is to order stone and wood samples according to the colours of the rainbow.

Technical information and practical experience of painting materials for façades and internal facilities helps students to understand the work of professionals —where the difficulties are, and which possibilities are available to solve problems.

A guided tour through the centre of Salzburg regarding the quality of colour, paint and plaster on façades shows the participants the importance of the effect of the external environment on inhabitants and visitors. The shape, design or style of the façade, the quality of the surface of the plaster or other materials, the quality and effect of the colour as well as the sequence and change of the materials, form a pleasant and relaxing, or disturbing, or monotonous optical climate.

## THE METHOD OF COLOUR PLANNING

The method of colour planning and its professional presentation numbers also among the basic subjects of the IACC education. A new colour project is systematically analysed and characterized: where is it, what is it, when does the period of planning and execution start and finish, or with whom does the colour consultant have to cooperate? Using the “semantic profile” or “profile of polarity” the quality of the project can be specified and it is also a simple medium of (self) control.

As mentioned before, according to the IACC best practice, the results of colour planning are not executed on the PC monitor, but in the form of colour collages. To give the customer an authentic impression of what he/she is going to receive, the IACC Academy Salzburg decided to create colour collages made with the actual materials and their colours, chosen for use on the project. Therefore, the problem of how to get the colour from the monitor on to the wall or façade is avoided.

## DAYLIGHT AND ARTIFICIAL ILLUMINATION

Great attention is paid to daylight and artificial light and their consequences for humans and their environments. The quality of natural light changes during the day and has an enormous influence on human’s body regulation of its functions. The colour consultant has to note this reaction as well as

the change of colours in the whole environment. He/she has also to deal with the great change of colour under artificial illumination and the effects of brightness, reflection and dazzling.

The lecture on “Biological aspects of light and physiological reactions on colour stimuli” goes even deeper regarding the effect of light and colour on the human body. Scientific research in the fields of medicine, physiology, psychology and neurology is important especially for the colour planning of hospitals, institutions of health care and homes for retired people.

The students realize the importance of these theoretical instructions when the lecturer passes over to colour for hospitals and psychiatric departments. Colour has harmonising and healing capacities and helps also to diminish stress. Conscious use of colour and orientation has a definite importance in this kind of environment.

### **NEUROPSYCHOLOGICAL AND VISUAL-ERGONOMIC ASPECTS**

“Neuropsychological and visual-ergonomic aspects of colour planning” informs about the use of interdisciplinary scientific research. The participants learn how the human body reacts in detail to colour stimuli, what happens in the brain or skin, which glands are involved and how they react. As a consequence, the colour designer has to take these physical reactions into serious consideration, using them as basics for appropriate colour choice.

In the workshop called “How to present myself and my work” the participants themselves experience how to work as a professional colour consultant. This psychological training shows each one where his/her talents lie, where the weak points are and how to work with, or to compensate for them.

### **COLOUR AND ARCHITECTURE**

The theme of “Colour and architecture” starts with instruction of scientific research on human reactions to architectural environments. The proportions of the space, light, material and colour affect the well-being of the users. Therefore the colour consultant has great responsibility regarding his/her colour design.

“Acoustics and colour planning” is a relatively new subject of the IACC curriculum. The increasing presence and irritation of noise in our environment made it necessary to insert also the theme of acoustics into our education. In fact, the colour consultant has to collaborate with acoustics professionals regarding the form, surface and colour of the material.

With a short overview of architectural art history students are informed of the various architectural styles, forms and colours. Images of modern cities, urban units or single buildings show not only the change of materials used in buildings but also the great difference between the past and today.

In 2017, in a non-profit project, the IACC Academy had the chance to demonstrate the professional execution of colour planning in a town, creating a new palette for the city.

Sending my abstract to the AIC jury of this conference, it was mentioned, that in my lecture there is no connection with the main theme of this conference. OK, it was not mentioned in my abstract, but in fact, especially dealing with colour and town, you cannot overlook the intense influence of nature on the image of a city. In most of the old centres of small or large settlements, the colours of the natural stones or bricks, which were used indoors as well as outdoors define the colour climate.



Figure 3: Colour samples of an old and new palette / Colour collage of an old city / Colour collage of a new palette.

For the city of the mentioned project, stones—in the colour sequence from light whitish ochre to medium brown— were used as well as bricks, which also had a mainly light yellow ochre colour because of the high percentage of kaolin found in the surroundings. They are not red! And of course we had to respect the colour climate of this place as base for the new palette.

Recently we had three students who wrote their thesis exactly on this field of knowledge taking the colour material of the surrounding neighbourhood into consideration.

### COLOUR AND COMMUNICATION

The lecture regarding “Colour as communication” informs about the use of colour and form and its psychological meaning for publicity and marketing. By showing images and diagrams, the enormous effect of form and colour on clients or buyers and the quick change of the appearance of articles is discussed.

“Synesthesia – Colour and music” (CD cover design) and “Colour as psychological element of expression” underline again the effect of music and colour: hearing music and transforming the acoustic experience and feelings into a visual representation (in this case a cover design) is quite a challenge, but an interesting exercise: colours and forms shall interpret the content of music to catch attention and sell.

Showing images of paintings of great artists enables the students to experience the immense power of colour as a psychological expression. Van Gogh, Edvard Munch, Alexej von Jawlensky and Guassamin painted their sicknesses or sad or painful experiences, while Gustav Klimt expressed the mental troubles of others. For me he is the first social critic

### LIVING IN OLD AGE – MEDICAL ASPECTS. COLOUR PLANNING AND ILLUMINATIONS SYSTEMS

“Living in old age – Medical aspects”, “Colour planning and illumination systems for homes of retired people” is an other huge subject of the IACC colour education. Besides information on the statistical developments regarding this special theme, the medical aspects of physical conditions and the needs of elderly people are the absolute basics for colour planning in this sector. A speciality of our lecturer, Med. Dr. Stefanie Gurk is the presentation of overalls. She developed these clothes to simulate various sicknesses such as stroke—or Parkinson’s disease! Putting the overalls on, the participants learn much about the loss of capacity to walk normally, to sit comfortably on a chair and get up again, or the loss of clear sight. The colour consultant has to pay great attention to these facts and to do his/her best to compensate for these impairments.



Figure 4:  
Dr. Stefanie Gurk presenting the posture of an old body.

A visit and guided tour through a home for retired people is the next step to inform the students about the necessity of careful colour planning for this group of humans.

The collaboration with a specialist producing illumination systems for homes of retired people and hospitals offers the occasion to learn more about how to illuminate these institutions in the best way to help users with reduced sight and to prevent accidents.

### **COLOUR AND PRIVATE HOMES**

“Colour and living area / or private home” is linked to the user’s character and his/her personal needs. An exercise makes clear to the students how important it is, to have a balanced colour climate in the area where someone lives. The home —as place of shelter and relaxation— has the function to compensate for the over —or under— stimulation and above all the stress of the working area and the external environment.

### **COLOUR AND LIGHT ON STAGE**

The aim of the subject “Dramaturgy, light and colour on stage” is to train the participants to work in small groups of 3 or 4 persons. According to the context of a real opera, with text and music, each participant is responsible for one single part, such as stage design, light design, costumes, etc. They all have freedom to develop their creativity. Coordinating their single units with the other members of the group should present a total solution at the end.

### **HOMEWORK AS PRACTICAL EXPERIENCE**

Besides the lectures, our curriculum provides lots of exercises for homework, on the way this process is achieved in reality. The participants gain experience by planning offices, nursery schools, various other kind of schools, hospitals, places of work and industry, homes for retired people and colour in towns. The students are given plans of real projects with all the instructions and conditions, necessary for responsible colour planning. The solutions are carefully corrected by the lecturers in the following seminars.

## **CONCLUSION**

Working as an IACC colour consultant does not mean promoting one's own egoism, but serving people, to provide a human, coloured and balanced space in which it is worthwhile to live and work.

In 2015 the Munsell Foundation carried out a global study examining the colour education programmes of colour institutions. The IACC Academy Salzburg is very pleased having been nominated among the best first four.

Let me conclude with a short statement of our former IACC president Frank H. Mahnke:  
**COLOUR IS MUCH MORE THAN DECORATION.**



# Challenging current colour theory and practice using thermochromic and photochromic inks in textile design

**Marjan Kooroshnia**

The Swedish School of Textiles, University of Borås, Sweden  
marjan.kooroshnia@gmail.com

## ABSTRACT

This paper attempts to use two series of design experiments, which used reversible, water-based thermochromic and photochromic inks, to highlight the challenges that come with using them when studying, teaching, and designing with them. It stresses the fact that we, as textile teachers, researchers, and designers, need to rethink the ways in which we teach, study, and design with colours. The complexity of the challenge that we face today perhaps lies in the foundations of our colour knowledge and design processes, which are not appropriate when smart colours are involved. It may be that an entirely new colour system or model that can be applied to both static and dynamic colours should be established.

**Keywords:** *thermochromic inks, photochromic inks, textile design, dynamic surface patterns, colour theory and practice*

## INTRODUCTION

In the latter decades of the twentieth century, chromic colours that reversibly change colour according to external environmental conditions were introduced, and so became available to designers, including textile designers. Often referred to as ‘smart colours’, these included thermochromic inks (activated by heat), photochromic inks (ultraviolet [UV] light), electrochromic inks (electricity), hydrochromic inks (water), and piezochromic inks (mechanical pressure). These introduced new design possibilities for textile and fashion design, and challenged and questioned colour theory and practice.

Leuco-dye based thermochromic inks (referred to hereafter as simply ‘thermochromic inks’) are coloured when below their activation temperature and clear or have a very light hue above the activation temperature (Bamfield and Hutchings 2010). They are usually blended with static pigments in order to change from one colour to another.

Photochromic inks are clear when not activated, and become coloured after exposure to sunlight or other UV radiation for 5 to 10 seconds (Bamfield and Hutchings 2010).

A colour can be described with regard to three properties: hue, value, and saturation (Wong 1993, Itten 2003: 34-55). In practice, the primary colours of most types of pigment are pure yellow, pure red, and pure blue, and every other colour can be made by mixing two or more of these. When two pure primary colours are mixed, a secondary colour is created; these include orange, violet, and green (Osborne 2008: 4). When a pure primary colour is mixed with a nearby secondary colour, a tertiary colour is created, for example yellow-orange and red-orange (Feisner 2006: 9).

Over the centuries, colours have been mixed according to three basic colour-mixing systems; subtractive, additive, and partitive (Gordon and Gordon 2002: 72, Albers 2006: 22-27). These models have formed the foundations of colour systems for centuries. Although many such systems exist, some have had a greater impact on the development of colour theory and practice in both academia and industry than others. Colour wheels and systems are “colour arrangements or structures” (Feisner 2006: 8) that enable designers to organise and predict colours, colour mixtures, and their interactions, as well as to communicate colour choices to manufacturers, customers, and other designers (Itten 2003, Albers 2006, Hård and Sivik 1981).

Detailed theoretical and practical investigation of existing colour principles and systems raises a number of important issues. These systems allow textile designers, particularly those who are interested in textile printing techniques, to determine a colour, as well as to determine the reaction or interaction that a particular colour would cause in a specific scenario. They do not, however, support textile designers during design processes that involve thermochromic and photochromic inks, as they cannot predict the behaviour of thermochromic and photochromic inks in relation to external stimuli such as heat and UV light.

Although many textile practitioners and researchers have experimented with and investigated the design possibilities offered by thermochromic and photochromic inks (Melin 2001, Orth 2004, Berzina 2004, Berzowska 2005, Ledendal 2009, Worbin 2010, Robertson 2011, Hashida et al. 2011, Rajapakse et al. 2015), research into creating dynamic surface patterns for textiles has progressed relatively slowly. This may be due to a lack of understanding of the challenges that textile designers face when designing dynamic surface patterns using thermochromic and photochromic inks, the unchallenged status of existing colour principles and systems with regard to the properties of thermochromic and photochromic inks, and a lack of proposed solutions to these issues. This deficiency may have caused textile designers to see only complexity in the use of thermochromic and photochromic inks, rather than extensive and practical possibilities. This paper presents two series of design experiments that used reversible, water-based thermochromic and photochromic inks in order to highlight the challenges that are involved in studying, teaching, and designing using smart colours.

## **RESEARCH PROCESS**

### **Thermochromic inks: Experiment series 1**

This experimental research project began by using the printing paste recipes suggested in the author’s PhD thesis (Kooroshnia 2017: 43-57), consisting of thermochromic inks with activation temperatures of 31 and 15°C. The inks change colours, presenting different hues in non-heated, heated (or the end colour lose point), and cooled states (or colour returned point). This was achieved by mixing thermochromic slurry with activation temperatures of 31 and 15°C with extender in different proportions (Figure 1).

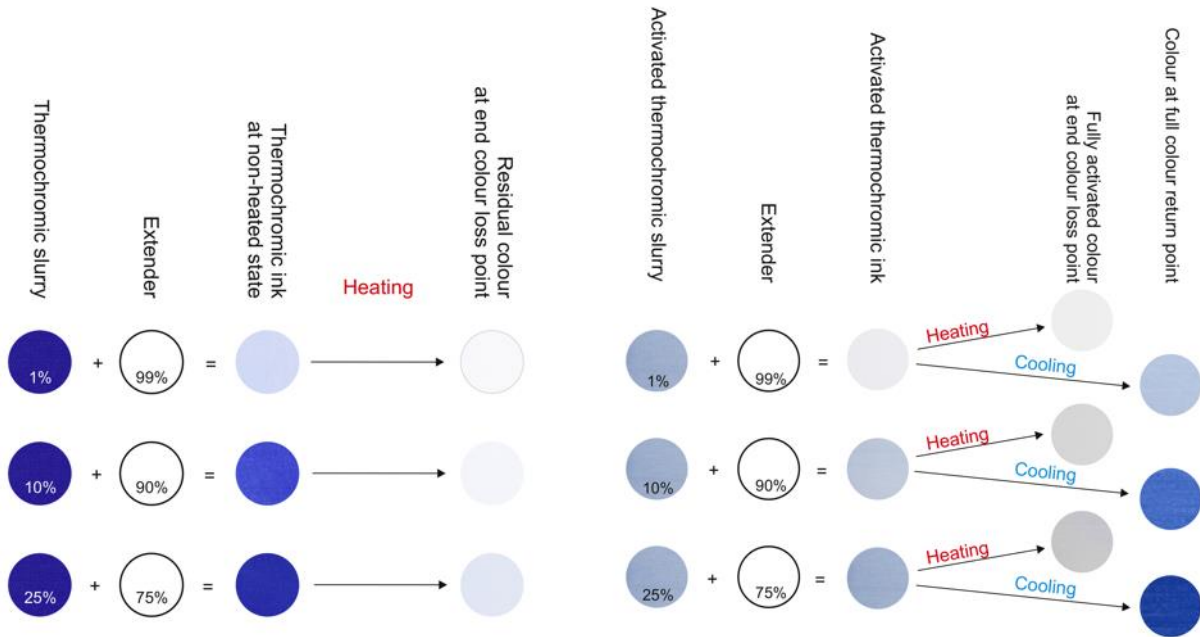

Figure 1: Printing paste recipes consist of thermochromic inks with activation temperatures of 31 (on the right) and 15°C (on the left). The inks change colours, presenting different hues in non-heated, heated, and cooled states.

A method of mixing colours to create a temperature-sensitive mixture of multiple inks (Kooroshnia 2017: 82-88) was then used to expand the range of ways of designing dynamic surface patterns in terms of revealing latent colours and designs. Four temperature-sensitive colour mixtures were produced; as the temperature was raised, the mixtures activated and began to change from dark brown to four different colours (Figure 2).

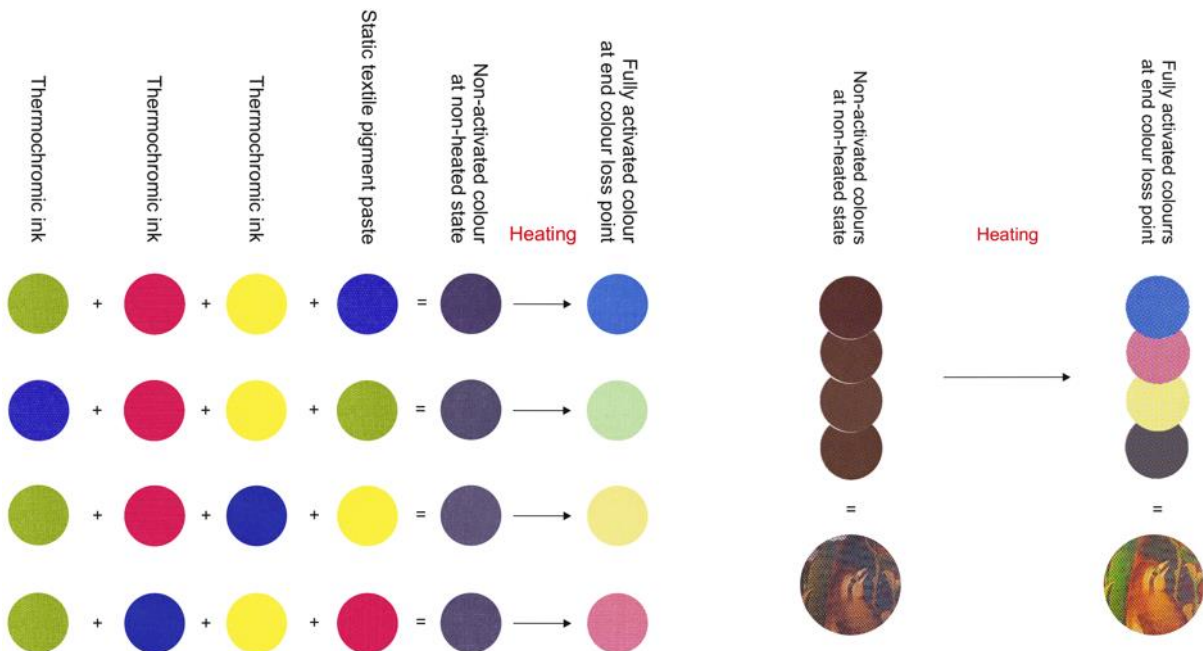

Figure 2: A method of mixing colours (thermochromic inks 31°C and static pigment paste) to create a temperature-sensitive mixture of multiple inks (on the right). A method for printing a complex dynamic pattern that combined the offset method of printing with a temperature-sensitive mixture of multiple inks (on the left).

Two or three different dynamic patterns were designed for each series of experiment. All of the patterns were inspired by Persian designs due to personal interest and cultural background, and featured flowers, birds, Islamic geometrical patterns, and arabesque designs.

The first pattern had three different visual expressions; one at non-heated state (ambient temperature), one in a heated state, and one in a cooled state. A dynamic pattern was created using thermochromic inks with activation temperatures of 31 (green) and 15°C (blue), and yellow static textile pigment paste (Figure 3).



Figure 3, from left to right: The printed fabric produced by inks with activation temperatures 31 and 15°C, the effect at non-heated state, the effect of heating and the effect of cooling the printed fabric.

For the second pattern, a printed fabric was produced using four temperature-sensitive colour mixtures (Figure 2); these consisted of thermochromic inks with an activation temperature of 31°C and extender, mixed in a ratio of 25:75. Magenta static textile pigment paste was used in the first mixture, yellow in the second, blue in the third, and green in the fourth (Figure 4).

For the third pattern, a textile printing method (Kooroshnia 2017: 108-111) that combined the offset method of printing with a temperature-sensitive mixture of multiple inks was used. A screen-printed pattern on 100% polyester fabric was produced using the temperature-sensitive colour mixture; the first layer consisted of cyan textile pigment paste, and layers of magenta, yellow, and then black textile pigment pastes were printed on top. When the temperature was increased, the temperature-sensitive ink mixtures were activated and changed from dark brown to vibrant colours (Figure 5). It should be noted that the figures used in this paper consist of photographs of the prints.

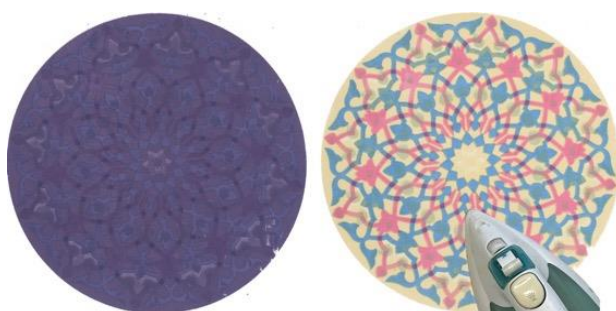

Figure 4, from left to right: The printed fabric produced using four temperature-sensitive colour mixtures consisting of thermochromic inks with activation temperatures of 31°C and static textile pigment pastes, the effect at non-heated state, the effect of heating the printed fabric.



Figure 5, from left to right: The printed fabric produced using four temperature-sensitive colour mixtures consisting of thermochromic inks with activation temperatures of 31°C and static textile pigment pastes, the effect at non-heated state, the effect of heating the printed fabric.

### Photochromic inks: Experiment series 2

This series of experiments began by using photochromic inks in primary colours (magenta, yellow, and blue), which were printed on a plain white woven poplin cotton fabric. Photochromic slurry was mixed with extender in a ratio of 50:50.

In order to explore colour mixtures when two different photochromic inks in primary colours are mixed, three colour scales were created. Mixing two photochromic inks in different proportions until the desired number of intermediate colours was obtained produced a gradated scale, progressing from one colour to another. In total, each scale had eleven steps/shades. The colour-changing effects were possible to observe through exposure to sunlight or UV light (Figure 6).

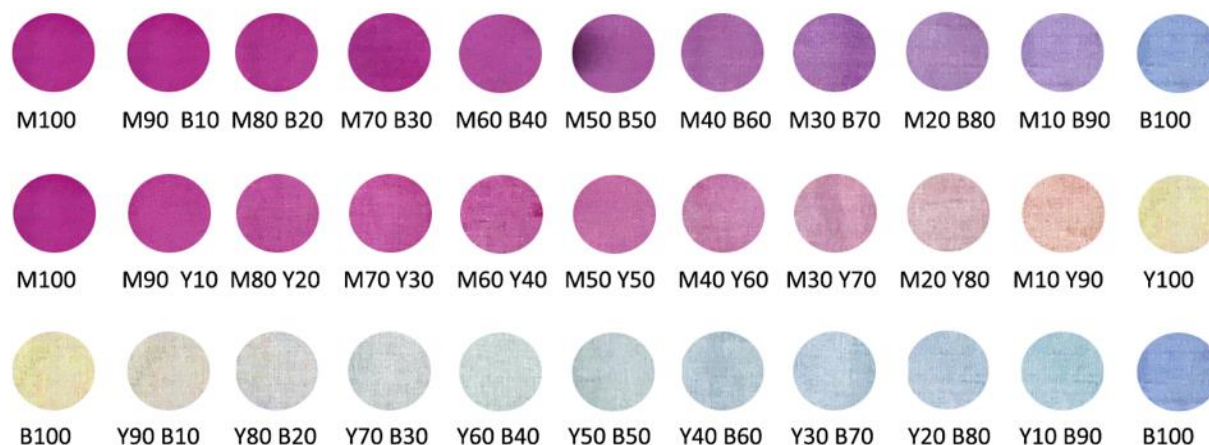

Figure 6: Three colour scales produced by mixture of two different photochromic inks in primary colours after exposing to sunlight.

Observation of the colour-changing effects suggested the idea of mixing photochromic inks with static textile pigment paste to expand the range of colour-changing effects. When this was put into practice, the results indicated that the static textile pigment paste prevented UV light from reaching the ink, inhibiting the colour-changing process of the photochromic inks. The best way to combine photochromic inks with static textile pigment paste seems to be to use the halftone technique, which allows UV light to reach and activate the photochromic inks.

A dynamic geometrical pattern was created using photochromic inks. The aim was to design a pattern which had only one visual expression after exposing to daylight and UV radiation (Figure 7).



Figure 7: from left to right: the printed fabric produced using photochromic inks, the effect at non-exposed state, the effect of exposing the printed fabric to sunlight.

For the second pattern, which was similar to the third pattern of Experiment 1, the offset method of printing was used to design a dynamic pattern. For the reasons stated above the halftone technique was later chosen in order to expand the range of colour-changing effects offered by photochromic inks. A screen-printed pattern on 100% polyester fabric was produced using photochromic inks; the first layer consisted of cyan, which was followed by magenta and yellow layers. This was then overprinted with a layer of black static textile pigment paste, as photochromic inks are not available in black. Exposure to sunlight activated the photochromic inks, which changed to vibrant colours (Figure 8).



Figure 8: from left to right: the printed fabric produced using photochromic inks overprinted with a layer of black static textile pigment paste, the effect at non-exposed state, the effect of exposing the printed fabric to sunlight.

## CHALLENGES

### Designing dynamic patterns

The fundamental skills required to successfully design a surface pattern include drawing expertise, knowledge of printing techniques, and the ability to understand the context of a design (Terashima 2009, Cole 2007). Traditionally, the surface pattern design process begins with a theme or brief as a guideline that directs the textile designer towards the desired visual elements (Wong 1993). During the process of visual development, colour plays an important role due to its ability to enhance, redefine, disguise, diffuse, or emphasise other design elements. Colour should be selected in such a way that the effect of the chosen colour is impossible to attain using another colour. Finally, textile designers must know how to turn their designs into a seamless, repeating pattern (Day 1999, Russell 2011).

The introduction of thermochromic and photochromic inks to textile printing, however, has challenged textile designers, offering a range of colours that can change the visual expression of textiles. As a result, textile designers also need to understand how thermochromic and photochromic inks behave under different conditions, and how this may impact the design process.

Moreover, textile designers need to know all possible printing paste recipes, as well as how each recipe behaves when temperature or light conditions change. A thermochromic slurry to extender ratio of 25:75, for example, produced a mixture with maximal colour intensity in a non-heated state and maximal residual colour in a heated state. A ratio of 1:99 produced a light colour in a cooled state, but less or even non-residual colour at ambient temperature (Figure 1). Based on this knowledge, a thermochromic, geometrical pattern was designed. Green thermochromic ink with an activation temperature of 31°C (thermochromic slurry mixed with extender in a ratio of 10:90) was used to produce less residual colour in a heated state. Blue thermochromic ink with an activation temperature of 15°C (thermochromic slurry mixed with extender in a ratio of 1:99) was used, and was invisible in a heated state and produced a light blue colour in a cooled state (Figure 3). A conversational photochromic pattern was printed based on the knowledge gained as a result of the creation of the recipes (Figure 8). Cyan (slurry to extender ratio of 50:50), magenta (slurry to extender ratio of 10:90), and yellow (slurry to extender ratio of 50:50) photochromic inks were layered. The reason for the ratio of magenta differing from the other two inks was that the scales representing the mixtures of yellow and magenta and blue and magenta showed that true orange or violet can be achieved if the percentage of magenta in the mixture is 10% (Figure 6).

In designing a dynamic surface pattern, inks and their behaviours, the quality of the chosen fabric, heat and UV sources (the sun or a UV bulb), and time should be considered as design variables from the beginning of a process, potentially simultaneously due to the fact that all have a strong impact on the overall aesthetic expression.

Textile designers must be able to predict the visual expressions that result from different conditions, and clearly visualise which colours are visible in a non-activated state and which are invisible or visible in an activated state, as well as which balance which others. Figure 3 shows a process in which colours and forms for the three different phases were decided simultaneously. Sometimes, the method of printing decides the order of colours. Combining the offset method of printing with a temperature-sensitive colour mixture, for example, is a complex process with regard to creating the temperature-sensitive colour mixtures, but it is fairly easy to decide the order of the layers and predict the colour-changing effects because the offset technique itself defines these (Figure 2).

These inks can be used on a broad variety of textile materials and thicknesses. The choice of textile has a significant impact on colour-changing effects, in that it can influence how quickly heat, for example, is conducted by the textile. A silk organza thermochromic printed fabric is very thin, and so as the temperature increases it changes from a coloured fabric to a colourless one in the blink of an eye. The heat that was transferred to the plain cotton fabric and polyester used in the sample prints, however, spread more slowly, giving a viewer more time to observe the thermochromic colour transition. In addition, the density of the chosen plain cotton and polyester fabrics provided a greater contrast with regard to observing the photochromic colour transition after exposure to sunlight.

Different heat and light sources create different colour-changing effects due to variation in thermal energy output, the time required for sufficient heating to take place, and the distribution of heat, which also influence how the forms and motifs of dynamic surface patterns change. The heat

generated by the iron that was used in this research project, for example, was high, meaning that the change in colour occurred so quickly that only two states were visible; one expression (colour) before, and another after. The heat generated by the body, on the other hand, is less intense, creating a gradual change in colour. The use of conductive threads in woven or knitted textiles creates another type of colour-change effect, in which the conductive threads themselves create a dynamic surface pattern that is influenced by the structure of the weave or knit (Worbin 2010, Dumitrescu et al. 2014). Similarly, light intensity and time of exposure affect the colour-changing effects produced by photochromic inks, in that the amount of UV light on cloudy and sunny days are different, for example, leading to different photochromic colour transformations.

With regard to digitally designing a dynamic surface pattern, finding the exact colour of thermochromic and photochromic inks in software packages such as Adobe Photoshop or Illustrator, as well as predicting the resulting colour transition, is difficult. Further research of a technical nature regarding graphical applications is required in order to create a colour index of thermochromic and photochromic ink transitions.

In addition to these factors, and how each affects colour-changing effects, the concept of dynamic colour interaction should be considered when planning a design process. Through Albers' (2006) concept of colour interaction, a textile designer gains an understanding of how to create optical illusions and predict which illusions will occur. Using thermochromic inks to create dynamic patterns on textiles offers the possibility of dynamic colour interaction and illusions at three different points in time; when the textile is in a non-heated state, when it is in a heated state, and when it is at a point in time between the two. An optical illusion can occur in a non-heated state and become another illusion in a heated state, or not be apparent in a non-heated state and be revealed in a heated state. Similarly, photochromic inks can create dynamic colour interactions, as is exemplified in the following examples.

The Bezold effect is an optical illusion wherein adding or changing one colour of a composition can, under certain circumstances, alter the colour of the entire design (Albers 2006: 33). Here, two identically coloured shapes are surrounded by a thin border; one is white and one is black, and so the colour of the latter appears to be darker than that of the former.

Thermochromic inks offer a variation on this concept: One of static textile pigment paste is surrounded by a thin border of black thermochromic ink. Red static textile pigment paste, for example, is surrounded by a thin black thermochromic ink border. The expression in a non-heated state is dark red, but when the textile is heated to the activation temperature of the ink, the thermochromic ink border becomes colourless, creating a lighter red colour.

Optical colour mixing occurs when two or more colours are placed in close proximity to one another against a white background. Using this technique, yellow, red, and blue dots on a white background combine to create orange, violet, and green. Using photochromic inks and the offset method of printing described above, a variation on this was achieved: Blue, magenta, and yellow photochromic inks and black static textile pigment paste were applied to textiles through offset printing, and exposing the print to sunlight caused viewers to perceive a colourful pattern due to the phenomenon of optical colour mixing (Figure 8).

A colour-movement illusion is created for example by choosing two coloured sections and altering their saturation or values that a continuous colour spectrum is created. By using thermochromic inks, however, colour movement can be achieved in another way. The thermochromic ink arabesque print was divided into eight individual parts; when each was heated, the colour-changing effect created led the eye in a certain direction (Figure 9).



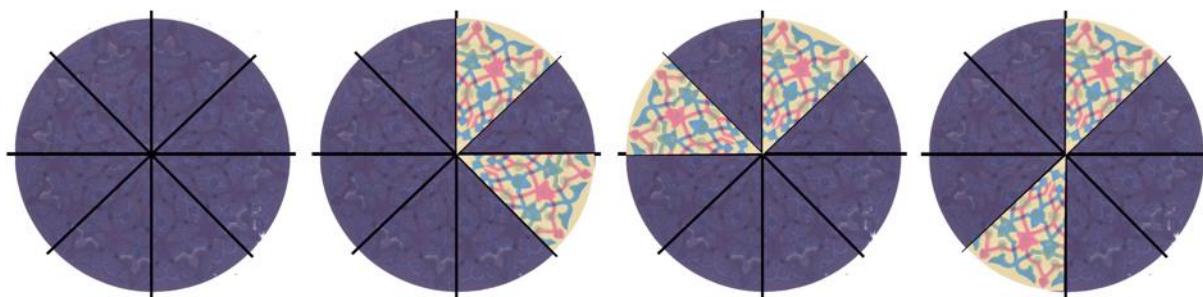

Figure 9: A colour movement illusion created by heating different parts of the thermochromic printed fabric.

Using smart colours when designing a dynamic pattern challenges the principles and elements of design. In *Colour*, Feisner states that “colour can reflect mood, emotion, time frame, and provide the symbolism” (2006: 65). Moreover, dark compositions give “feelings of night, darkness, mystery and fear” (Feisner 2006: 42). The conversational pattern that was created as part of this research had a dark-brown visual expression in a non-heated state. When the temperature was increased, the temperature-sensitive colour mixtures were activated, and the textile changed from dark brown to vibrant colours (Figure 5). Thus, the dark emotion of the inert textile changed to become a relaxed, less demanding expression. Feisner also argues that repeating hues creates rhythm and a feeling of movement (Feisner 2006: 66), and this links to the reversible colour-changing behaviour of the photochromic inks used in the design of the geometrical pattern: exposure to sunlight caused the pattern to exhibit a form of colour movement during the colour-changing process, and another with regard to the elements of the design (Figure 7). This indicates that thermochromic and photochromic inks not only interact with other principles and elements of design such as rhythm, balance, proportion, scale, emphasis, and harmony, as static colours do, but suggest dynamic alternatives to them.

Many designers consider the symbolism of colours (Feisner 2006) when designing a surface pattern. Within this concept, black, for example, has negative connotations relating to death, emptiness, depression, etc.; alternatively, it can have positive inferences of sophistication, power, luxury, etc. These meanings and associations pose the question of how colour symbolism can be utilised in relation to smart colours —when, for example, designing a product wherein black thermochromic ink changes to white as a result of an increase in temperature.

### Colour system

Textile designers are often visual learners, and thus learn through observing. This may be the reason why the colour circles and systems were established —to visually and verbally represent colour theory, to enable artists and designers to organise and predict colour mixtures (and their interactions), and to communicate colour choices to other artists and designers along with manufacturers and customers. This raises the question of whether these systems are able to verbally and visually describe the colour-changing effects of thermochromic and photochromic inks, and to factor in the use of heat and UV light as design variables. The answer to this question, however, is no; they are not able to visually represent the basic and complex colour transitions of thermochromic and photochromic inks. As is shown in figure 4 and 5, temperature-sensitive colour mixtures are able to change from one colour to multiple. Almost all existing colour systems or models explain the

alternating relationships between primary, secondary, and tertiary colours, as well as the relationship between each of these and black and white. The fact that they are unable to describe how temperature-sensitive mixtures can change from one colour to various others, and then back again to the first (from colour A to colours B or C, D, E, F, etc., and back again to colour A) indicates that there is a need to incorporate the dimensions of temperature and time into existing colour systems.

Lack of colour principles and systems that can assist textile teachers and designers in effectively communicating the possibilities of thermochromic and photochromic inks affects teaching, studying, making informed decisions, and predicting colour transitions for different environmental conditions when designing a dynamic surface pattern. Consequently, their absence affects design processes in terms of the repeatability of colour-mixing processes, as accurate printing paste recipes require colour measurement. Due to the current absence of a thermochromic and photochromic colour database with which to measure the dynamic prints using a spectrophotometer, it is impossible to put existing colour principles and systems into practice.

### Terminology

One challenge when studying, teaching, and designing with thermochromic and photochromic inks is the lack of appropriate terminology with which to describe and discuss the behaviour of them in relation to external stimuli such as temperature and UV light. In *The material of invention*, Manzini (1989) stresses the fact that exploring the design properties of new materials is not concerned solely with the discovery of new design possibilities; rather, the experiments should also suggest new terminology with which to discuss these design possibilities. It is near-impossible to teach and study the behaviour of thermochromic and photochromic inks by employing existing theories and practical terminology, which are intended for static colours.

As is shown in Figure 1, it was observed that a blue thermochromic ink with an activation temperature of 15°C (thermochromic slurry mixed with extender in a ratio of 1:99) was invisible at ambient temperature, and changed to light blue in a cooled state. In existing colour systems or models, a light colour is made solely by adding a large quantity of white to a colour; in this case, however, no white was added to the thermochromic ink, and instead heat and time were involved. This indicates that, at present, the lack of terminology makes it very difficult to describe a colour-changing effect without giving the audience the wrong impression when, for example, attempting to describe the behaviours of thermochromic inks at varying temperatures. Suggested new vocabulary could include terms such as ‘non-activated colour’ and ‘fully-activated colour’, rather than ‘colour change from a fully saturated colour to a light one’.

### CONCLUDING DISCUSSION

Over the course of the last two decades, time, heat, and UV light have become design variables, but theories and academic work have consistently failed to factor them in. In addition, the applications of these parameters are not limited to smart colours, as new technologies continually involve them further in the textile design area. Bethany Rose Coggins, a master’s student in textile design at the Kolding Design School in Denmark, explores the design properties and possibilities of dispersive dyes in digital heat transfer printing applications by working with heat and time. ‘Transfer printing’ is the term used to describe textile and related printing processes in which the design is first printed on to a specially designed sheet of paper, then transferred onto a textile using heat.

During her research project, Coggins has explored how heat and time can transform and affect the colour of dispersive dyes. She has created more than 550 different tints and tones from four original dispersive dyes (red, yellow, blue, and turquoise), which were heated at 185, 195, 205, and 215°C for periods of between 10 and 40 seconds.

This emphasis on heat, time, and UV light needs to be added to colour models and systems in order to facilitate improved understanding and design of surface patterns in the context of textile design.

Due to their colour-changing properties and ability to be controlled, thermochromic and photochromic inks have the potential to propose new forms of communication in terms of temperature, air pollution, sound, and so on. In order to skilfully use these smart colours, however, proper design and communication tools are needed.

## ACKNOWLEDGEMENTS

I would like to acknowledge to Smart Textiles, an initiative of the Vinnova Vinnväxt programme for financially supporting my research, as well as Bethany Rose Coggins, a master's student in textile design at the Kolding Design School in Denmark for sharing her research project.

## REFERENCES

- Albers, J. 2006. *Interaction of color*. New Haven, CT: Yale University Press.
- Bamfield, P., and M. G. Hutchings. 2010. *Chromic phenomena: the technological applications of colour chemistry*. London: Royal Society of Chemistry.
- Berzina, Z. 2004. *Skin stories: charting and mapping the skin*. London: University of the Arts, PhD thesis.
- Berzowska, J. 2005. Electronic textiles: wearable computers, reactive fashion, and soft computation. *Journal of Textiles* 3 (1): 2-19.
- Cole, D. 2007. *Patterns (new surface design)*. London: Laurence King.
- Day, L. F. 1999. *Pattern design*. New York: Dover Publications.
- Dumitrescu, D., M. Kooroshnia, and H. Landin. 2014. Exploring the relation between time-based textile patterns and digital environments. In: *Proceedings of Ambience 14&10*, Sept. 2014, Tampere, Finland.
- Feisner, E. A. 2006. *Colour; how to use colour in art and design*. London: Laurence King.
- Gordon M., and B. Gordon. 2002, *The complete guide to digital graphic design*. New York: Watson-Guptill.
- Hård A., and L. Sivik. 1981. NCS- Natural Color System: A Swedish standard for color notation. *Color Research and Application* 6 (3): 129-138.
- Hashida, T., Y. Kakehi, and T. Naemura. 2011. Photochromic sculpture: volumetric color-forming pixels. In: *Proceedings of SIGGRAPH 2011*, Vancouver, Canada.
- Itten, J. 2003. *The elements of color: A treatise on the color system of Johannes Itten based on his book The art of color*, ed. by E. van Hagen. New York: John Wiley & Sons.
- Kooroshnia, M. 2017. *On textile printing with thermochromic inks*. University of Borås, The Swedish School of Textiles, PhD thesis.
- Ledendal, M. 2009. *Chromatic chlorophyll - Conceptual hospital textiles with chromatic smart materials*. University of Borås, The Swedish School of Textiles, master thesis.

- Manzini, E. 1989. *The material of invention*. Cambridge, MA: The MIT Press.
- Melin, L. 2001. The information curtain: Creating digital patterns with dynamic textiles. In: *Proceedings of CHI '01 Extended Abstracts on Human Factors in Computing Systems*. New York: ACM, 457-458.
- Orth, M. 2004. Dynamic double weave. In: *Fashionable technology*, S. Seymour, eds. New York: Springer, 75.
- Osborne, R. 2008. *Colour influencing form: A colour course book*. London: Universal Publishers.
- Rajapakse, D., A. Briggs-Goode, and T. Dias. 2015. Electronically controllable colour changing textile design. In: *Proceedings of IASDR Interplay 2015*. Brisbane, Australia, 2-5 November 2015.
- Robertson, S. 2011. *An investigation of the design potential of thermochromic textiles used with electronic heat-profiling circuitry*. Heriot-Watt University, Edinburgh, United Kingdom, PhD thesis.
- Russell, A. 2011. *The fundamentals of printed textile design*. London: AVA Publishing.
- Terashima, A. 2009. *Pattern factory*. New York: Collins Design.
- Wong, W. 1993. *Principles of form and design*. New York: John Wiley & Sons.
- Worbin, L. 2010. *Designing dynamic textile pattern*. University of Gothenburg, Sweden, PhD thesis.

# Presenting colours in a museum: mediation and scenographic principles

Natacha Le Duff<sup>a\*</sup>, Anne Cogan-Krumnow<sup>b</sup>

<sup>a</sup> Museum of Colours, Berlin, Germany

<sup>b</sup> Kleio & Co.

\* natacha@museum-of-colours.org

## ABSTRACT

The association for a Museum of Colours (MOC) in Berlin works on different types of exhibitions to transmit knowledge about colours in their diversity, tackling their scientific, artistic and symbolic aspects. Since 2018, we defined the narration of a permanent exhibition, structured around five parts: perceiving, observing, producing and using, creating and interpreting colours. The first part, “The perception of colours”, became the focus of a collaboration with scenography students from the Technical University of Berlin. Together, we developed a methodology in order to transfer our narration into 3D space, using moodboards, models, and installations to scale. We also focused on the diversity of our audiences, and the variety of mediation means. This collaboration enabled the MOC to reach a new phase of concrete development.

**Keywords:** museography, scenography, interactivity, audience diversity

## INTRODUCTION

Since 2013, the Museum of Colours has worked on the conception of a permanent exhibition dedicated to the multidisciplinary topic of colours, with an anthropological approach. The planned permanent MOC will allow visitors to discover the topic by following five key pathways: perceiving, observing, producing and using, creating and interpreting colours.



Figure 1: Extract of a project file from November 2018, introducing the main ideas of each stage.

To demonstrate our way of introducing colours in a museum context, we will focus on the first part of the planned permanent exhibition, entitled “The perception of colours”. This is an especially interesting one, since it contains the introduction to the whole museum, and thus many diverse elements about the nature of colour. Although, the risk is to present everything into details and suddenly create too many divisions rather than connections to other parts of the museum. However, this introduction should be self-sufficient and self-understandable.

Currently there is a huge gap between the detailed narration of the permanent exhibition and the realisation of a museum. We wish to grow little by little to understand how our concept functions in three-dimensional spaces. Different scales can be observed: from showcasing exhibits to creating the organisation of the different rooms, through the creation of proper installations and original ways to display knowledge.

In order to start prototyping our vision, from October 2018 to February 2019, we developed a partnership with the Masters “Set Design and Scenic Space” of the Technische Universität Berlin, whose director was willing to have students collaborating with us. They helped us create innovative scenographic installations that provide accessible ways to experience new things about colours, such as to display elements of knowledge. Through a series of interactive lectures, they got to understand the main ideas and challenges of the MOC. This allowed them to dig deeper into different directions and work on how to implement specific topics.

Our key questions were:

- How to apply our narration concepts and principles into space?
- How to create special means of scenography that would best convey our ideas?

In order to transmit knowledge to a wide audience, we need to implement various mediation means, which adapt to the diversity of people’s background knowledge, but also their profiles, ages and ways of learning: learning by watching, reading, and also doing, experiencing, inhabiting, leaving a trace. This paper will examine the process of translating our narration into three dimensional spaces and installations.

## **CONTEXT AND METHOD**

After having established the five parts of the Museum and their contents, we wished to reach a new level of concretisation, which led us to contact the director of the Masters programme “Bühnenbild, Szenischer Raum” at the Technical University of Berlin, who showed a lot of enthusiasm towards our project and wished some of her students to get involved in it. After a short project presentation to the entire class, four students decided to contribute to the MOC as a semester side-project. Our collaboration was spread out over four months with various phases and weekly meetings.

Collective sessions first consisted of the introduction of the whole project and its narration, such as a detailed presentation of its first part, “The perception of colours”, which is made up to six sub-parts:

- Fundamentals about colour perception
- Variations in human colour perception
- Animals colour perception
- The five senses of colours
- Perception in question
- Naming colours

These sessions led us to answer many of the students' questions, but also to define certain scenographic requirements that we already had regarding this first part. Then, we choose the topics from which the students would be free to create their own projects. We deliberately let them be free to get creative with these topics, since our method is based on the belief that each collaborator of the project has their own unique point of view about colours, and that the MOC should be the result of the convergence of these visions. We believe this is a key element to enable us to address the real diversity of people.

Furthermore, especially as we work with a universal topic, inclusion is a central question for us. How can we address visitors with different cultural backgrounds and physical abilities? Which devices and furniture can we use to improve the accessibility?

Because we believe that colours affect everyone, we also wish to be able to address a wide audience, including children, babies, the elderly, and visitors experiencing different types of impairments (cognitive, physical, also visual!). We also consider cultural mediation through guiding and leading to be a meaningful form of transmission.

This led us to organise a session about accessibility in cultural institutions, in partnership with Anne Cogan-Krumnow, founder of Kleio & Co., a French-German association dedicated to cultural mediation. The multidisciplinary of the subject also suggests a diversity of exhibits, which has to be integrated into spaces following special criteria. Finally, the realisation of a general plan of the themes allowed us to spread out the themes and installations among the students.



Figure 2: Overview of the pathway “The perception of colours”.

Then, an individual working phase made of research and sketching, allowed the students to dig deeper into different topics and start finding intellectual and aesthetical affinities. They created various moodboards, which were collectively discussed. This enabled their vision to become more precise about what they intended to conceive.

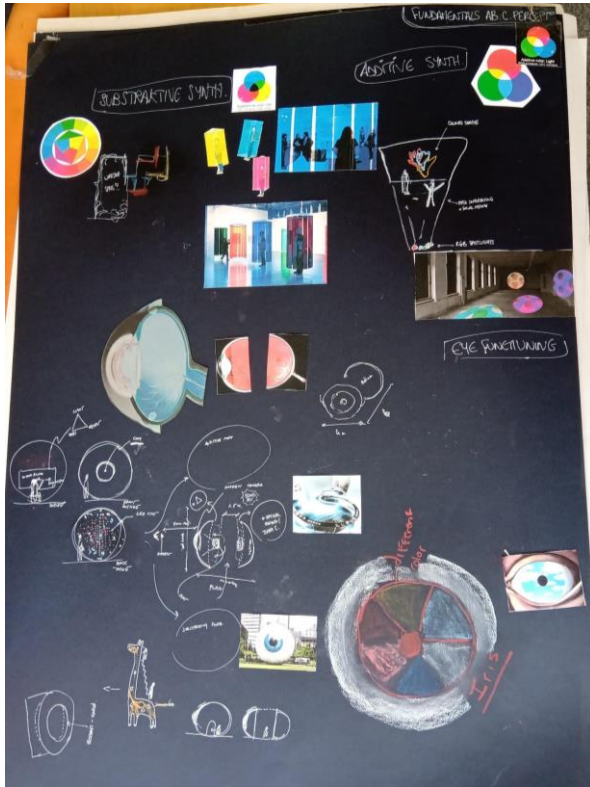

Figure 3:  
Moodboard "The fundamentals of colour perception".

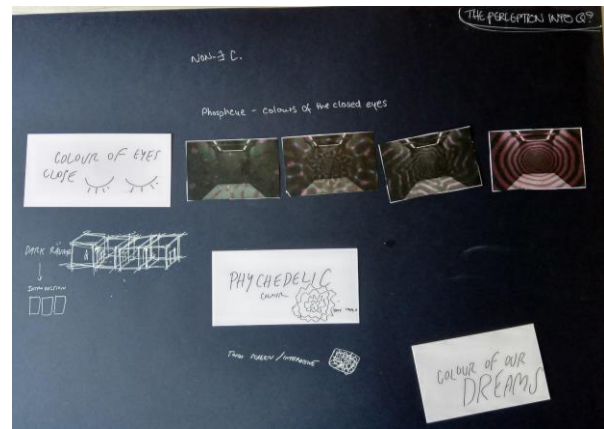

Figure 4:  
Moodboard "Perception in question".

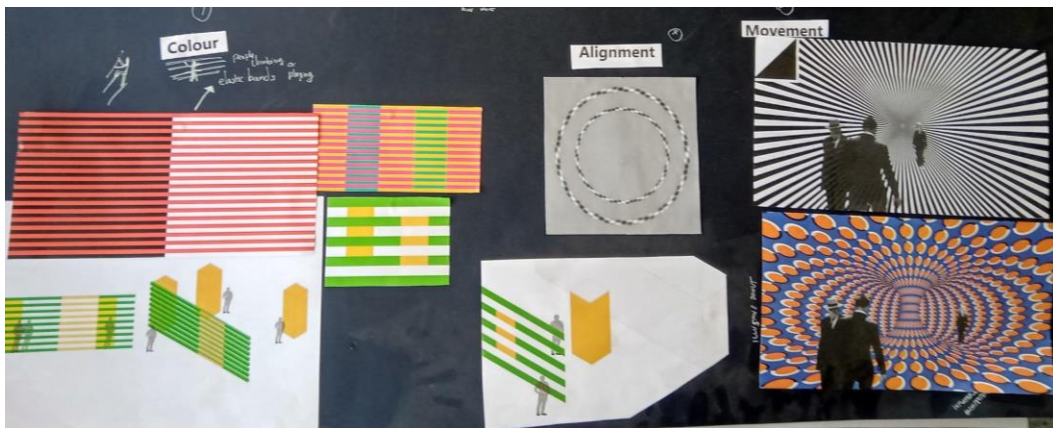

Figure 5: Moodboard "Optical illusions".

From these moodboards, the students created their own models, following the same basic rules of materials and scale, such as taking into account the number of potential visitors in each room.

A third step was the preparation of at scale installations. Each student selected one of their themes, to envisage how it could look in the permanent exhibition.

Finally, we assembled the different parts of the model and defined a general visitors' pathway. The final presentation to the teachers and Masters' director was an opportunity to critique the students' creations with a professional look. Beyond good grades, the students received very good appreciation from their teachers.





Figure 6: Overview of the different parts of the model.

## EXPERIMENTS

In this part, we will observe the transposition of our narration into three-dimensional spaces. The experiment went through two main steps: the realisation of a model, and the implementation of installations to scale. The creation of a model for the first part of the museum allowed us to transfer our narration and pedagogical requirements into potential spaces. It will help us to define more precisely our needs and thus to search for the right place to contain a permanent MOC.

We wish to create interactive scenographic devices to allow a better understanding of theories and concepts. For instance, we developed a game to implement the Stroop effect on our visitors. The Stroop effect is the cognitive dissonance which is created by reading a colour word written using another colour, for instance: **blue**. This game takes the form of a “Stroop dance revolution” where one would have to step on the colour that is written, not the one that they can perceive. Points will accumulate with each right answer, starting slowly to allow an adaptation time and then going faster, to provide the audience a physical sense of what the Stroop effect is. The best players will have the chance to add their names to the game’s billboard. The principle of this game is based on a simple mediation reflection: how to encourage our visitors to be physically active to help them understand and remember concepts? A version made out of buttons would allow more people to play.

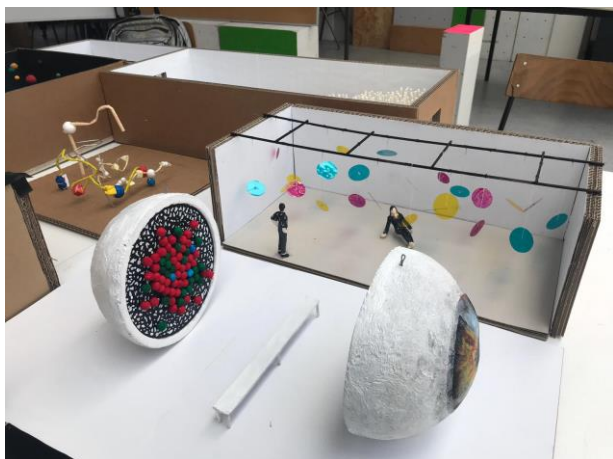

Figure 7: Model of an eye and installation to illustrate the subtractive synthesis.



Figure 8: Model of the "Stroop dance revolution".

Immersion is a key-concept in our scenographic approach to colours. For instance, to give a better understanding of the colours which appear with closed eyes, we will create a phosphenes' room: a dark room with 360° projection of patterns corresponding to what humans can see with closed eyes. The visitors will be invited to switch the patterns until finding the one that resembles their personal experience the most. They will then be invited to vote for their corresponding pattern, thus leaving a trace of their personal perception of colours in the museum.



Figure 9: Representation of phosphenes.

Scenography can also help to convey knowledge: to illustrate Berlin & Kay's theory of the evolution of words to name colours, we picture a structure in seven steps corresponding to the development of languages. These steps will be surrounded by a field of sticks with multilingual labels corresponding to the colours of each stage. Information can also be displayed on each platform. By involving the physicality of climbing steps, our visitors should not only understand but also feel the evolution of colours' words in languages. A wheelchair ramp should be integrated into the installation.

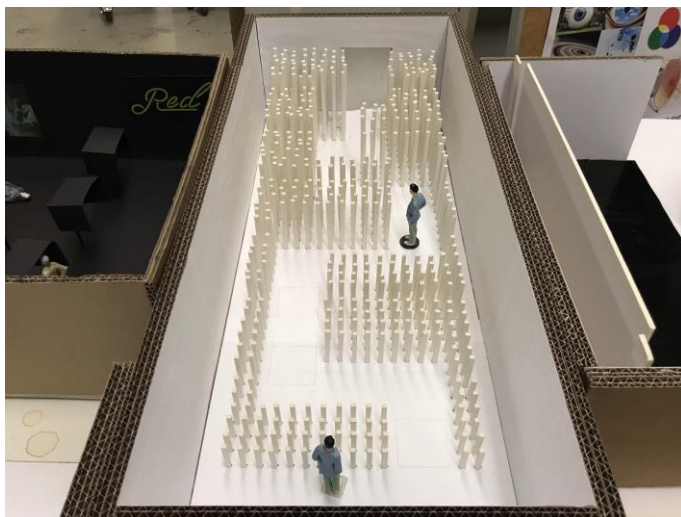

Figure 10:  
Model of the installation to illustrate  
Berlin & Kay's theory about colour naming.

In order to introduce the diversity of animals' perception of colours, one of the students started picturing a sort of planetarium, where planets would be replaced by animal eyes. She imagined that animals with the same number of cones' types would be on the same concentric circle (orbit), and that one would find the mantra shrimp —with its fourteen types of cones— at the center of this circle.



Figure 11: "The planetarium of animals' eyes".

## RESULTS AND DISCUSSION

Working with young curious scenographers who originally did not know much about the project was very challenging, since their questions required us to justify each and every decision that we took about the logical connections inside the Museum. Colours can be perceived as a whole, and connections can exist between many different fields, following different logic. Through this process, we noticed that coming back to the anthropological perspective deeply grounded our approach.

Defining contents is about setting limits: to introduce the perception of colours, it is necessary to start with light and a few basic explanations. Though, we should not evoke Newton's theory yet, since it would require us to connect it to other colour theories, which will be addressed later in the Museum. Following our anthropological approach, Newton and the diffraction of light should be attached to their cultural context and set in perspective with other colour theoreticians.

Understanding a few key concepts, they quickly got creative and brought new perspectives to our museographic concepts. In this context, leaving freedom to creative minds led to many good inputs.

Because the students were evaluated individually, they also had to produce individual models and installations, which brought some lack of continuity and transition spaces. Some more general aesthetic logic of the whole space could have been implemented. Meanwhile, a closing session together with the work of one of the students with a degree in architecture allowed us to conceive a general plan of all subparts connected together. Furthermore, the students knew each other since more than a year and were used to collaborating; one of them quickly identified as their team coordinator.

More time would have allowed us to estimate a production budget, such as implementing more installations to scale.

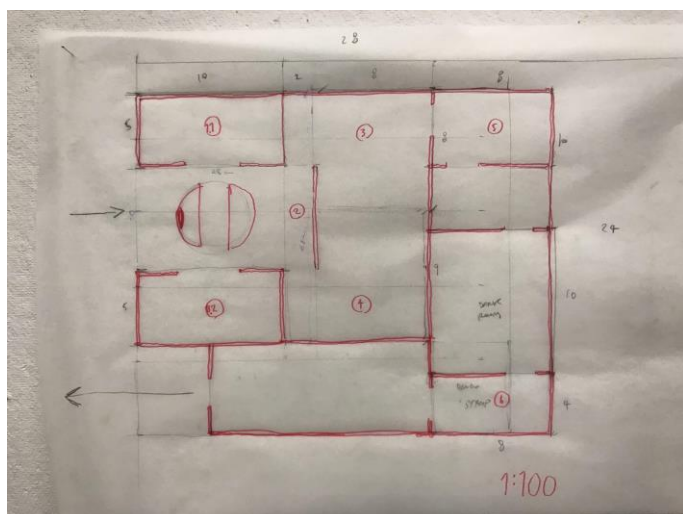

Figure 12:  
General plan of “The perception of colours”.

## CONCLUSION

Our concept for a Museum of Colours has been evolving constantly since 2013, with more concrete ideas continually emerging for the establishment of a permanent museum. Each new step brings us to more refined possibilities. Thus, we can start estimating the dimensions of the whole permanent exhibition, which can apply to different buildings.

The whole process will lead us to prepare a three-dimensional preview of the first part of the MOC. For this purpose, we will work with architects and virtual reality, to provide an intense immersion feeling. We plan to renew the experience with a new group of students and set our focus on “Producing and using colours”, which is the third part of the MOC, from November 2019 on.

## ACKNOWLEDGEMENTS

We wish to especially thank Kerstin Laube, director of the Masters programme Bühnenbild, Szenischer Raum (Technische Universität) and her students: Alejandra Alarcon Bautista, Mara Barnabo, Svenja Stannat and Klong Suriya. We also warmly thank Anne Cogan-Krumnow, founder of Kleio & Co, a French-German organization dedicated to cultural mediation about history and archeology. We finally wish to thank Cath Carver for her help by the redaction of this article.

# Assessing the color learners' competence in multiple topics of essential color knowledge

Tien-Rein Lee<sup>a</sup>, Wen-Yuan Lee<sup>b</sup>, Pei-Li Sun<sup>c</sup>, Tsuei-Ju Hsieh<sup>d\*</sup>

<sup>a</sup> Department of Information Communication, Chinese Culture University, Taipei, Taiwan; Taiwan Association of Color Application (TACA)

<sup>b</sup> Department of Industrial Design, Tatung University, Taipei, Taiwan; Color Association of Taiwan (CAT)

<sup>c</sup> Graduate Institute of Color & Illumination Technology, National Taiwan University of Science and Technology, Taipei, Taiwan; Taiwan Association of Color Application (TACA)

<sup>d</sup> Department of Information Communication, Chinese Culture University, Taipei, Taiwan; Color Association of Taiwan (CAT)

\* tracy.tjhsieh@gmail.com

## ABSTRACT

To accelerate spreading color knowledge and to elevate color proficiency for local industry, Color Association of Taiwan (CAT), Industrial Technology Research Institute (ITRI), and Taiwan Association of Color Applications (TACA) have jointly developed a standardized system for color teaching, training, and certification. This system has been established and maintained by color experts in academic and industrial fields, and the Taiwan government authorizes it. The color learners enrolled in the system would acquire sufficient knowledge and skills, and those who pass the certification exams would be issued "Certified Color Planning and Managing Color Specialist" (CPMCS). *Basic Color Science* is a required exam subject to whoever chooses the field of color planning or engineering. The subject comprises multiple essential topics in the color area, and one's score of the subject fairly represents his/her basic literacy of color. This study presents the assessment results of *Basic Color Science* in the first certification in 2018. We examined over one thousand exam takers' scores in answering a total of 80 multiple-choice questions that are evenly covering central aspects of color knowledge. By comparing the correct rates between the exam topics and between the exam takers' backgrounds, we reveal the color learners' competence in various sub-areas of color, and this would be valuable information for the certification developers and color educators to dedicate to improve the system.

**Keywords:** color knowledge, Certified Color Planning and Managing Color Specialist (CPMCS)

## INTRODUCTION

Various industrial applications provide products or services involving the users' visual experience, such as displays, printing, textile, paints, product design, etc. Many of the employees within these

industries are expected to be capable of mastering the skills of color. Our previous survey on Taiwan's industrial needs for color professionals indicated that color is a popular, desirable specialty among the employment market of a manufacturing-based economy like Taiwan (Hsieh et al. 2018). However, we found that the systematic color education for the practical purpose was not readily accessible to general color users or learners, as the color knowledge encompasses a wide range of multiple domains (Witcher 2016). With the expectation of promoting color proficiency for local industry, in the past three years, Color Association of Taiwan (CAT), Industrial Technology Research Institute (ITRI), and Taiwan Association of Color Applications (TACA) have jointly developed a standardized system for color teaching, training, and certification. This government-authorized system with a well-organized training and certification plan is now known as "Certified Color Planning and Managing Color Specialist" (CPMCS). The detailed description addressing the establishment of the CPMCS system is given in our previous publication (Hsieh et al. 2018). The certification of the associate level of the CPMCS is further divided into two fields, color planning, and color engineering. *Basic Color Science* is a required exam subject for both certification fields, while the other two elective exam subjects are *Practice of Color Planning* (for CPMCS Color Planner) and *Colorimetry* (for CPMCS Color Engineer). The exam subject *Basic Color Science* comprises multiple essential topics in the general color area. As the subject content was designed through a rigorous procedure involving experts consulting, the question bank developing and pretesting, and numerous refining, we believe that the examinee's score in this subject would fairly represent his/her basic literacy of color. This study presents the assessment method and results of *Basic Color Science* in the first certification in 2018.

## METHODS

Figure 1 depicts the overall flow of organizing CPMCS exam. The preliminary works concentrate on investigating expectations of color-related industries, as well as integrating the inputs from academics. All these constructive suggestions from empirical surveys were submitted to the committee board responsible for establishing the Occupational Competency Standards (OCSs) of CPMCS. The establishment of OCSs is a theory-based (Smith and Keating 2003) regularization procedure advised by the Industrial Development Bureau (MOEA) of Taiwan, and OCSs would serve as a basis for further development of teaching material, training courses, and finally the exam design.

With the well-defined OCSs as a backbone that would form the outline of exam content, we recruited color experts from diverse academic and industrial backgrounds to generate and review a comprehensive questions bank for three exam subjects. All the exam questions had been carefully reviewed and refined through an examination procedure holding double-blind evaluation and pretest.

The subject in concern, *Basic Color Science*, covers four major exam topics entitled 1. Color Phenomenon, 2. Basic Color Application, 3. Color Psychology, and 4. Principles of Color Harmony. As shown in the detailed list in Table 1, each of the four exam topics within *Basic Color Science* scores at a rate of 35%, 35%, 18%, 12%, respectively, with each sub-topic scores approximately at 6%. These topics with reasonably proportioned scores constitute the exam scoring of *Basic Color Science*. The form and the amount of the exam questions are 80 multiple choice questions with only one correct answer each. The questions correspond to every sub-topics and are formulated in the above-mentioned proportion. Such scoring provides an adequate assessment of the learners' competence in various topics of essential color knowledge. The national-wide CPMCS exam is held in mid-May and mid-December annually. The three organizations, CAT, TACA, and ITRI, are responsible for different parts of the CPMCP exam.

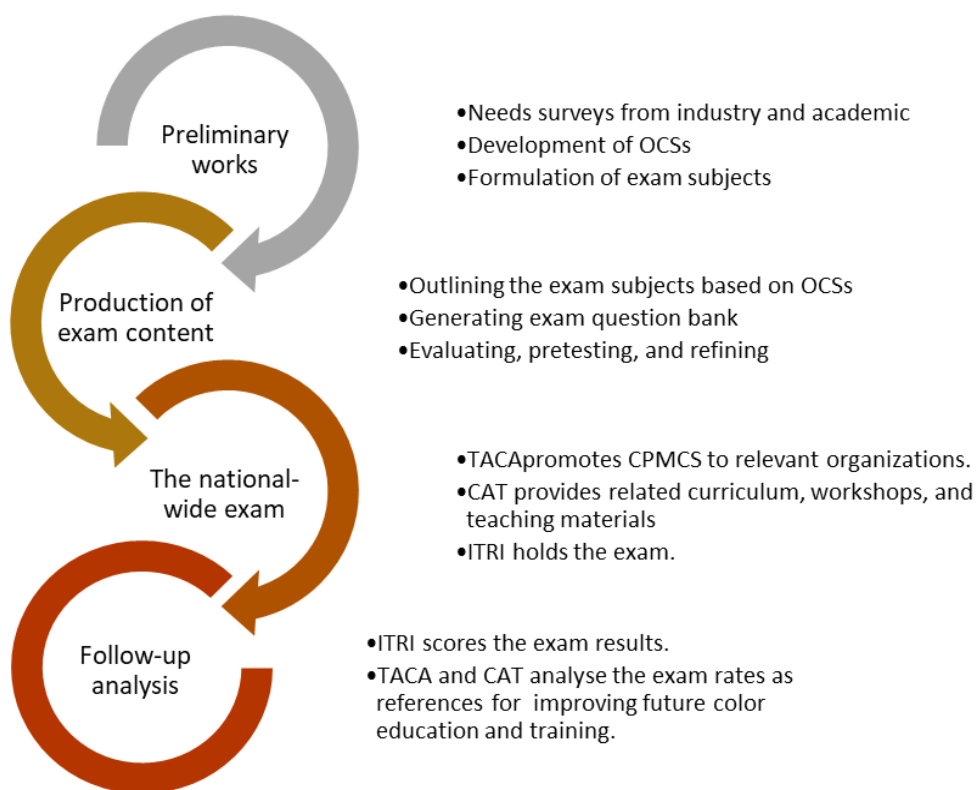

Figure 1: The overall flow of the preparation, organization, and executive works of CPMCS.

Exam Subjects	Exam Topics	Proportion (%)	Exam sub-topic
Basic Color Science	1. Basic Color Theories	35%	1-1. Seeing Color
			1-2. Color Vision Theory
			1-3. Color and Lighting
			1-4. Elements of Color Vision
			1-5. Color Order System
			1-6. Principle of Color Mixing
	2. Basic Color Application	35%	2-1. Digital Color
			2-2. Basic Colorimetry
			2-3. Color Reproduction
			2-4. Basic Color Planning
			2-5. Basic Color Management
			2-6. Basic Electro-optical Color
	3. Color Psychology	18%	3-1. Color Perception
3-2. Color Visibility and Saliency			
3-3. Color Contrast and Assimilation			
4. Principles of color Harmony	12%	4-1. Tone-based Color Harmony	
		4-2. Hue-based Color Harmony	

Table 1: The exam topics, sub-topics, and each scoring rate of the required subject, *Basic Color Science*.

### PRELIMINARY RESULTS

As the flowchart is shown in Figure 1, after holding the national-wide CPMCP exam on specified dates, ITRI scores the exam takers' results and provides the grades to TACA and CAT. TACA evaluates the certified rates correlating to the exam takers' organizations and adjusts their promoting strategy for

the next round of CPMCS exam. CAT members responsible for developing materials and curriculum examine the distribution of detailed scores/correct rates and review the actual teaching and training methods, and improve their educational works for the potential exam takers in future exams.

Figure 2 presents the preliminary results of the subject *Basic Color Science* in the 2018 CPMCS exam. The histogram shows the mean correct rate corresponding to each sub-topics among the overall examinees (N = 1638) along with the results of a compared group (N = 218). The exam takers of the compared group were upperclassmen or graduate students from the college of journalism or mass communication. The majority of the group studied visual communication and graphic design, while a few of them had a science or engineering background. The purpose of showing the results of a specific group is to demonstrate that the score analysis would be beneficial for whom intends to compare the performance between different groups of background. Several facts revealed in Figure 2 are worth mentioning. The sub-topic *Basic Color Planning (2-4)* results in an accuracy rate of over 95%, while *Color Visibility and Saliency (3-2)*, and *Hue-Based Color Harmony (4-2)* both reach 90%. The high accuracy rates indicate that the exam questions regarding these phases could be too easy to discriminate the examinees' knowledge level. On the other hand, the topics *Basic Color Management (2-5)* and *Basic Electro-optical Color (2-6)* resulted in relatively low accuracy rates. The discrepancy between the compared group and the overall is noticeable in the topic *Elements of Color Vision (1-4)* and *Principle of Color Mixing (1-6)*. The lecturers and trainers find the comparison if these scores helpful for preparing their students to attend the next exams.

The CPMCS exam has stepped into its second year of becoming the only regularly-held official color certification in Taiwan with considerable growing numbers of enrolled learners and exam takers. In the foreseeable future, we expect there will be thousands of people certified by CPMCS enter the color-related industries or get promoted as a result of the certification.

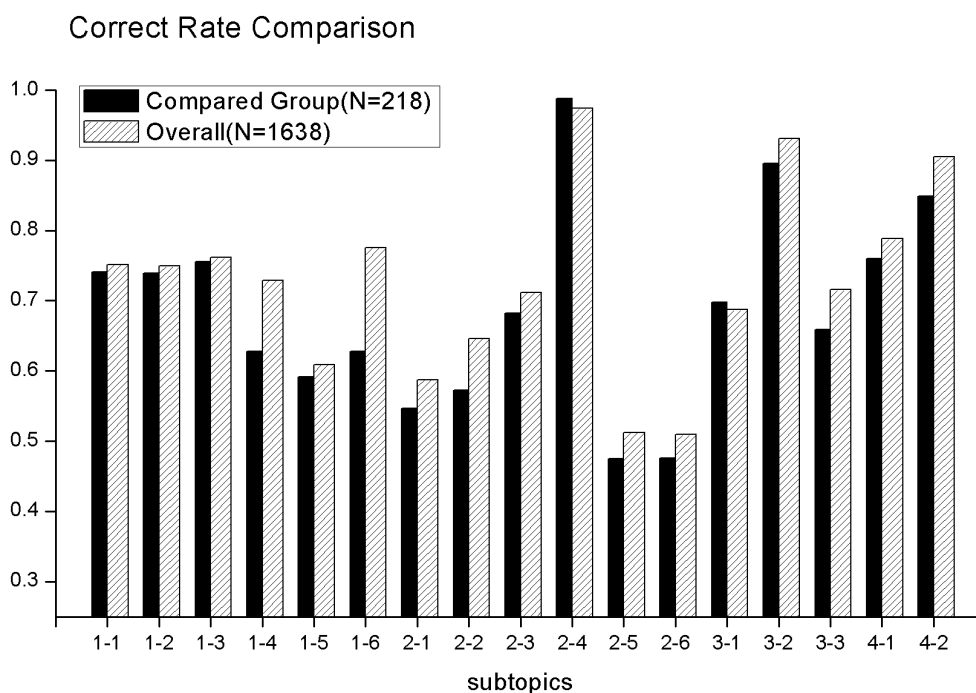

Figure 2: Correct rate comparison between sub-topics among all examinees and a compared group of examinees.



## REFERENCES

- Hsieh, T. J., P. L. Sun, W. Y. Lee, T. R. Lee, and W. I. Chen. 2018. Towards establishing an educating and certification system for color specialty: The experience of Taiwan. *Journal of the International Colour Association* 22: 41-51.
- Smith, E., and J. Keating. 2003. *From training reform to training packages*. Tuggerah Lakes, NSW, Australia: Social Science Press.
- Witcher, D. T. 2016. *Color fields: What designers need to know about color*. Austin: The University of Texas, master thesis.

# The Shillito Design School: an influential colour curriculum with historical links to the Bauhaus

Zena O'Connor

Design Research Associates, Sydney, Australia  
zena@zenaoconnor.com.au

## ABSTRACT

From 1962 to 1979, the Shillito Design School in Sydney was a landmark educational institution that represented a unique Australian link to the Bauhaus. The School's colour and design curriculum was so effective and influential that a lasting legacy includes the many former students who rose to prominence in Australia as well as the subsequent design schools in Sydney that adopted Shillito's colour and design curriculum. This paper honours the eminent status of the School by examining and recording the origins, extent and practical nature of the School's colour curriculum.

**Keywords:** *colour curriculum, colour education, colour theory and application, Bauhaus*

## INTRODUCTION

Founded in Sydney in 1962, the Shillito Design School offered a comprehensive and highly practical colour and design curriculum that had strong pedagogical links to the Bauhaus (O'Connor 2013). This paper acknowledges the landmark status of the Shillito Design School as well as the 100<sup>th</sup> anniversary of the founding of the Bauhaus in 1919 (BDF 2019). In particular, the colour component of the Shillito Design School's curriculum is examined and patterns of similarity with the colour theories of the Bauhaus curriculum, Johannes Itten and Josef Albers are highlighted. Drawing on recollections and portfolios of former Shillito Design School students, this paper provides an invaluable record of the School's colour curriculum. In an era when colour curriculum is often sidelined in tertiary education or shifted to online delivery, this paper will serve as a record of one of Sydney's influential design schools.

## PHYLLIS SHILLITO AND THE SHILLITO DESIGN SCHOOL

Phyllis Sykes Shillito (1895-1980) was born in England and taught art and design from 1919 until immigrating to Australia in 1923, where she taught design in Brisbane. Shillito subsequently taught at

East Sydney Technical College (ESTC) and was asked by James Nagle, NSW superintendent of technical education, to found a school of applied art and industrial design. This she did and the first design diplomas were awarded in 1936. Shillito retired at age sixty-five in 1960 and within two years, she opened the Shillito Design School at 36 Grosvenor Street, Sydney in 1962. The School, which offered a three year design and colour certificate course, continued at its location until Shillito died in early 1980 (Kent 2002, Morrow 2005).

Shillito's ideas about design and colour had roots in the Arts and Crafts movement as well as Modernism (Morrow 2005). However, strong patterns of similarity exist between her curriculum, and the Bauhaus foundational Basic Course as well as the colour theories of Johannes Itten and Josef Albers. The Bauhaus Basic Course was initially devised by Itten when the school was established in 1919, under the direction of Walter Gropius. Subsequently, the Bauhaus moved to Dessau in 1925 and then Berlin in 1932, and Itten was succeeded by Paul Klee, Wassily Kandinsky and eventually Albers until the school was closed in 1933 (Albers 1963, Bayer et al. 1975, Itten 1961, 1963).

It's been noted that Shillito "borrowed progressive ideas from ... schools in Ulm and Munich" (Kent 2002). It is highly likely that Shillito was referring to the Ulm School of Design, located an hour east of Munich and it's rumoured that Shillito attended this school at some stage. Founded by Max Bill (former Bauhaus student) in 1953 along with Inge Aicher-Scholl and Otl Aicher, the Ulm School of Design adopted a design and colour curriculum similar to the Bauhaus (UDS 2019). When classes started in August 1953, the teaching staff included former Bauhaus educators Albers and Itten. Like the Bauhaus, Ulm students completed a foundational course in the first year before choosing a specialty, that included visual communications, product design and architectural design.

When Shillito developed her colour curriculum, colour theory featured foundational colour concepts and relationships. As such, colour theory reflected music theory, which also features foundational elements such as notes, scales, and chords which can be arranged to form any number of different music compositions and genres. Similarly, Shillito's students learned and applied basic colour concepts and strategies in tandem with design principles and practices. Shillito considered these integral to professional design practice: 'A student who has mastered the basic principles of design can design anything from a dress to a kitchen stove', an oft repeated dictum akin to the pedagogical approach of the Bauhaus. While Shillito's colour curriculum was taught before the advent of digital colour, there are many concepts that remain relevant to digital colour design.

## **SHILLITO DESIGN SCHOOL COLOUR CURRICULUM**

Shillito's course involved exploring and applying substance colour (with reference to formula colour products such as Pantone) rather than colour in the form of light-waves (Green-Armytage 2006).

Shillito's colour curriculum began with basic colour identification and classification concepts which were applied to design exercises. Students explored a range of simple through to more complex and nuanced colour relationships. These colour relationships represented colour strategies that could be applied to design and the built environment. In addition, various colour effects were studied along with techniques to manage or counteract these effects in applied design.

As per Itten's colour theories and colour theories in general at the time, the study of colour was underpinned by the notion that substance colour has three key attributes: hue, saturation, and tonal value. Hue was defined as the general category and perception of a colour labelled 'red', 'blue' or 'yellow'. Saturation was defined as the level of chromatic intensity or purity, along a continuum from

weak chromatic intensity to full chromatic intensity. Tonal value was defined as the lightness or darkness of a colour, with all colours having an inherent tonal value.

Students were encouraged to explore variations of hue, tonal value and saturation level, within the context of practical colour design exercises. These exercises were essentially assessment tasks, and students painted and often repainted these to a high standard and then collated them in a portfolio. All colour exercises were completed using gouache paint (Winsor & Newton) and students were restricted to eight colours: cadmium yellow, lemon yellow, vermilion red, carmine red, ultramarine blue, Prussian blue, white and black. By completing these colour/design exercises, students gained valuable insight and practical experience of colour mixing and creation, colour relationships, and colour application. In this respect, the course mimicked that of the Bauhaus as well as Itten's assertion that "only through painting can the student discover the secrets of the world of colours" (Itten 1963: 32).

Shillito's colour curriculum can be divided into three main sections: basic colour concepts; simple through to nuanced colour relationships (colour strategies), and colour effects. Students used a limited colour palette which enabled them to fully explore colour, create colour nuances and experiment with basic through to more nuanced and sophisticated colour relationships.

**Basic colour concepts** **primary colour** and **secondary colour** were explored and their inter-relationships examined within the context of the Shillito colour wheel. Shillito's colour wheel model featured three primary colours (red, yellow, blue), reflecting substance colour theory traditions of the time. The model featured three key secondary colours (green, orange, purple) plus perimeter colours: red, red-orange, orange, yellow-orange, yellow, yellow-green, green, blue-green, blue, blue-purple, purple, red-purple. Shillito's primary and secondary colours reflected those of Itten, and her colour wheel was identical to Itten's colour wheel (Itten 1961, 1963) (Figure 1, left).

**Tonal value** was another basic colour classification included in the curriculum. Students explored tonal value by painting a grey scale, a vertical column of squares which featured white at the top, black at the bottom and seven greys in between. Students designed and painted illustrations that demonstrated variations of tonal value as well as a tonal value wheel, whereby the inherent tonal value of each colour from the colour wheel was identified (Figure 1, center). Shillito advised that tonal value and contrast were key elements in design and advocated the careful allocation of these to create focus and mood, while avoiding visual dissonance arising from harsh contrasts. Hence, a number of colour exercises explored ways to explore and address tonal value. Similarly, students of Itten, Albers and the Bauhaus were encouraged to explore achromatic colour, tonal contrasts and grey scales, plus create designs that illustrated variations of tonal value and their impact on mood and ambience.

**Chords and keys** represent specific tonal value groupings, and Shillito's students explored six chords and keys to examine how they contributed to focus, mood and ambience in applied design. Minor chords were considered to contribute to calmer ambience due to the absence of strong contrast but less effective in creating focus due to the relative absence of tonal value contrast. Major chords were considered equally effective in contributing to mood and ambience, as well as attracting attention and creating focus, given the stronger contrasting tonal values.

- High key, minor chord – predominantly light tonal values.
- High key, major chord – predominantly light tonal values with a smaller proportion of dark tonal values.
- Intermediate key, minor chord – predominantly mid tonal values.
- Intermediate key, major chord – predominantly mid tonal values with a smaller proportion of light tonal values and dark tonal values (Figure 1, right).
- Low key, minor chord – predominantly dark tonal values.
- Low key, major chord – predominantly dark tonal values with a smaller proportion of lighter tonal values.

Students painted multiple variations of chords and keys in achromatic and chromatic variations. Similarly, students of Itten, Albers and the Bauhaus were encouraged to explore tonal value and Itten referred to the 'subjective timbre' of chords and keys, and the impact on visual evaluation. Bauhaus students were encouraged to analyse the hues, tonal values, chords and keys of paintings by well-known artists such as Goya and Giotto; an exercise that was replicated at the Shillito Design School.

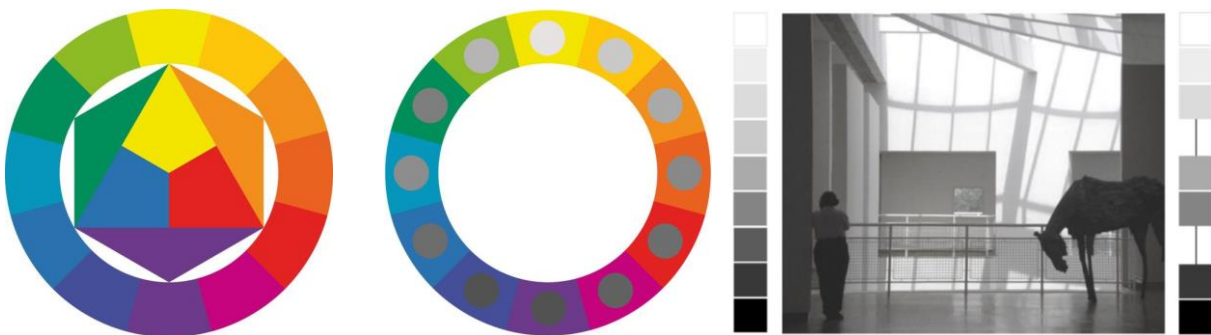

Figure 1: Shillito colour wheel (left); tonal value colour wheel with grey scale (center); intermediate key, major chord illustration (right).

**Colour contrast** featured in the curriculum. As per Itten, contrasting colours (also referred to as complementary colour) were defined by Shillito as hues that sit opposite each other on the colour wheel and which tend to intensify each other when placed in close proximity. Students explored colour contrast by painting a colour contrast wheel and designs that illustrated the impact of contrasting colour, including variations in tonal value and saturation. Shillito's course included seven types of contrast as identified by Itten: Contrast of hue, light-dark contrast, cold-warm contrast, complementary contrast, simultaneous contrast, contrast of saturation and contrast of extension.

**Simple harmonies** and **extended harmonies** were among the first in a series of nuanced colour relationships included in the curriculum. Simple harmonies (analogous colour) were described as a group of colours that exhibited hue similarity and which sit alongside each other on the colour wheel, such as yellow, yellow-green and green. Extended harmonies were described as a group of colours that shared hue similarity with the addition of a few colours that are marginally different in hue. Students painted simple designs to illustrate simple harmonies and extended harmonies colour strategies in variations of saturation level and tonal value. These exercises were similar to those devised by Itten and Albers to illustrate similar colour strategies.

**Tints and shade**, another category of nuanced colour included in Shillito's curriculum, were explored by painting a tints and shades chart and colour star (Figure 2, left and center). Shillito defined tints as colours with white added; while shades were created by adding small proportions of black, grey or a colour's contrasting colour as per the Shillito colour wheel model. Tints and Shades represented additional colour strategies for applied design and the built environment. Similarly, Itten's colour star illustrated the tints and shades of colour wheel hues and Bauhaus students also explored variations of tints and hues and the impact these have in colour design.

**Monochromatic colour** and **monotone** were additional nuanced colour classifications in Shillito's curriculum. Monochromatic colour was defined as a colour strategy based on one hue only, with variations of saturation and tonal level of that one hue. The relative consistency of hue despite the variations of saturation and tonal value helped to contribute to visual cohesion. Monotone was defined as a group of different hues, all of which featured the same tonal value level. The consistency of tonal value ensured a strong level of visual cohesion despite the range of different hues (Figure 2, right). This colour strategy was considered to contribute to a sense of calmness in the built environment; however, due to the relative lack of tonal value contrast, this colour strategy could be problematic in respect to creating strong focal points in graphic design.

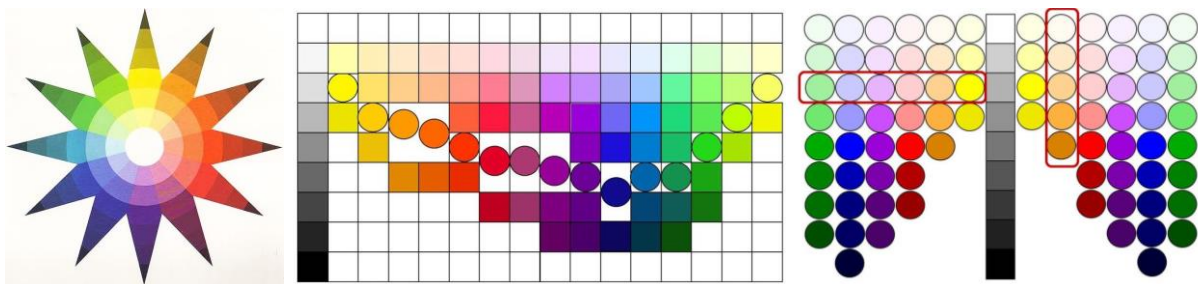

Figure 2: Tints and shades colour star (left) and chart (center); monotone colour and monochromatic colour (right).

**Chroma reduction** and **reduced contrasts** were additional nuanced colour strategies included in the curriculum. Chroma Reduction was defined by Shillito as colour reduced by the addition of grey (shadow palettes) or another (often contrasting) hue. Reduced contrast was defined as pairs of contrasting hues that have had the intensity of contrast reduced. This variant of chroma reduction was achieved by adding a small proportion of contrasting colour to its opposite colour to reduce the intensity of contrast, thereby providing a lively but more subtle contrasting colour strategy.

**Split complementary (triadic) colour** and **double complementary (tetradic) colour** represented nuanced colour strategies based on contrasting colour. Split/triadic complementary colour was defined as featuring a key hue and two hues drawn from either side of the key hue's contrasting colour, conveying visual variety with less intense contrast levels. Double/tetradic complementary colour was defined as two pairs of contrasting hues; thereby providing lively colour variety especially with hues high saturation level. Triadic complementary colour was defined as three colours taken from the colour wheel at approximately equidistant locations. Shillito advised that all contrasting colour strategies could be represented in a range of different tonal value and saturation levels. Albers references these colour strategies; however, he concluded that such strategies may not lead to positive evaluations due to the factors that impact responses to colour.

**Tertiary colour** represented another nuanced colour classification. Shillito defined tertiary colours as those that occur when a secondary colour such as orange (comprised of the primary colours, red and yellow) is mixed with the remaining primary colour, blue. As such, tertiary colour represented a large gamut of hue variations and students explored these by creating a tertiary colour wheel plus colour compositions based on tertiary colour. Certain tertiary colour palettes were assigned names reflecting their hue composition. For example, 'forest' colour palette featured tertiary hue gradations between orange and green; 'desert' colour palette featured hues between orange and purple, and 'mountain' colour palette featured hues between green and purple. Alternative variations of tertiary colour arose from the hue gradations between blue and orange, red and green, and yellow and purple.

**Simultaneous contrast** was among a number of colour effects included in the curriculum. Shillito advised students to be aware of colour effects due to their capacity to influence the appearance of colour in applied design. Shillito's definition of simultaneous contrast matched that of both Albers and Itten: an effect that occurs when context colour influences the appearance of a hue. Simultaneous contrast may generate an apparent change in hue, tonal value as well as saturation level. Shillito encouraged students to create designs that illustrated simultaneous contrast and the changes in hue, tonal value and luminosity that can occur as a result of simultaneous contrast.

**Colour discords, broken colour, vibrating colour, Bezold effect, dirty colour** as well as techniques to harmonise irritating colour combinations were included in Shillito's colour curriculum to illustrate colour effects and colour reactions that may impact colour design. Colour discords (also referred to as colour inversions) were deemed to occur when the 'natural' tonal order of a pair of colours is reversed. 'Natural' in this context was defined as the tonal value of hues as per the Shillito colour wheel and the tonal value wheel. Broken colour occurs when a hue is altered from its original colour wheel appearance by the addition of white, black, grey or contrasting colour; or, broken indirectly via the addition of a pattern overlay such as small dots or dashes. Vibrating colour occurs when two hues of similar saturation and tonal value appear to vibrate when in close proximity. The Bezold effect was defined as an effect whereby a change of one colour in a coloured pattern design changes the overall appearance of the design. Students painted a number of examples of the Bezold effect to illustrate its impact. Dirty colour is a variation of simultaneous contrast and was defined Shillito as an effect that could occur when the appearance of a hue was influenced by the colours surrounding it, making a bright, pure hue appear less so due to the influence of surrounding colours. Both Albers and Itten devised colour exercises that illustrated various colour effects including broken colour, vibrating colour and the Bezold effect, and made reference to instability of colour and the impact on colour design.

**Proportion and distribution of colour** within the context of applied design was considered important and Shillito advised that a 'good' colour scheme depended on effective and contextually relevant hue, tonal value and saturation relationships. To explore the proportional allocation of colour, students created and evaluated designs that varied hue, tonal value and saturation allocations, in varying proportions such as 60:30:10 (dominant, auxiliary and accent colour). In addition, like Bauhaus students, Shillito's students analyzed the proportional allocation and distribution of colour (hue, tonal value and saturation) in familiar paintings by well-known artists.

## THE SHILLITO DESIGN SCHOOL COLOUR CURRICULUM: AN INFLUENTIAL AND LASTING LEGACY

In an era when colour curriculum is being sidelined or shifted to online delivery, this paper will serve as an accessible record of the colour curriculum of one of Australia's most influential design schools. The colour and design curriculum of the Shillito Design School was so effective that a lasting legacy are the many former students who rose to prominence in Australia plus the subsequent schools that adopted the same or a very similar colour and design curriculum.

Shillito graduates include three of the six founding members of Society of Interior Designers of Australia (SIDA, established in 1951): Edmund Sykes, Donald Johnson and Mary White. White and Sykes were SIDA presidents, 1963-1964 and 1967-1968 respectively. The SIDA amalgamated with the Design Institute of Australia (DIA) in 1998 and a number of DIA hall of fame inductees and life fellows are Shillito graduates including Langdon Badger, Paul Schremmer and David Denne (former head of Postgraduate Design at the University of Technology, Sydney) and Olga Kardos (former head of Design Studies, Design Centre, Enmore TAFE).

After the Shillito Design School closed in 1980, former Shillito students Eva Fay and Prue Leith replicated the School's colour and design curriculum when they established the School of Colour and Design, Sydney, in 1983. The author taught at this school in 1999-2000 and can attest to the strong similarity in the colour and design curriculum between the two schools. In turn, the colour and design curriculum was adopted by the Sydney Design School in 2009, albeit with reference to requirements relating to the VET Quality Framework, a national system of qualifications in Australia.

## ACKNOWLEDGEMENTS

Thanks are due to Shillito graduates who advised on this paper: Victoria Ciddor, Jeni Hawkins, Kate Murphy, and Melissa Ward. Illustrations created by Zena O'Connor, a Shillito Design School graduate.

## REFERENCES

- Albers, J. 1963. *Interaction of color*. New Haven, CT: Yale University Press.
- Bayer, H., W. Gropius, and I. Gropius, eds. 1975. *Bauhaus 1919-1928*. London: Secker & Warburg.
- BDF. 2019. *Bauhaus Dessau Foundation – History*. Retrieved 4 June 2019, from <http://www.bauhaus-dessau.de/index.php/history>.
- Green-Armytage, P. 2006. The value of knowledge for colour design. *Color Research and Application* 31 (4): 253-269.
- Itten, J. 1961. *The art of color*, revised ed. New York: John Wiley & Sons, 1973.
- . 1963. *Design and form: The basic course at the Bauhaus and later*, revised ed. New York: John Wiley & Sons, 1975.
- Kent, C. J. 2002. Phyllis Sykes Shillito (1895-1980). *Australian Dictionary of Biography* 16: 235-236.
- Morrow, C. A. 2005. *Women and modernity in interior design: A legacy of design in Sydney, Australia, from the 1920s to the 1960s*. Sydney: University of New South Wales, PhD dissertation.
- O'Connor, Z. 2013. The Shillito Design School: Australia's link with the Bauhaus. *The International Journal of Design in Society* 6 (3): 149-159.
- UDS. 2019. The Ulm School of Design. Retrieved 18 May 2019, from <https://museumulm.de>.



# Colour harmony: a 2020 perspective

**Zena O'Connor**

Design Research Associates, Sydney, Australia  
zena@zenaoconnor.com.au

## **ABSTRACT**

Theories and guidelines that focus on colour harmony abound in the literature and occur across many sectors including art, design, physics, psychology and digital technology. Mainstream media is also awash with a range of colour harmony strategies, guidelines and formulae sourced from the literature on colour and used in applied design and digital colour application. However, the interface between colour and human response is complex and many of these colour harmony strategies and formulae do not reflect the range and variability of responses to colour. Advances in research as well as critical, theoretical analysis have prompted an updated colour harmony model plus additional colour strategies for applied design and digital colour application in an effort to address the complexity of colour and the range and variability of responses to colour.

**Keywords:** *colour harmony, colour theory, colour strategies, aesthetics, human response to colour*

## **INTRODUCTION**

Colour harmony is considered 'a sense of accord and balance among colours in a visual composition or design, resulting in a positive affective response and/or cognitive judgment about colour combination' (Nemcsics, O'Connor and Pompas 2016). While the logic of this statement is evident, it provides little insight into the complexity of colour or the variability of human response to colour.

As the year 2020 approaches, an opportunity exists to present an updated colour harmony conceptual model which aims to bring additional acuity to this construct. In addition, the existing range of colour harmony guidelines and formulae is extended to acknowledge the complexity of colour including three key attributes of colour, the highly variable nature of responses to colour and the practicalities of applied design and digital colour application.

## COLOUR HARMONY THEORIES – THEORETICAL AND ONTOLOGICAL PERSPECTIVES

Numerous colour theorists dating from antiquity have discussed colour harmony and presented colour harmony theories, strategies, guidelines and formulae. Many of these strategies and formulae have gained currency due to their long-term ubiquity and familiarity across mainstream media.

However, there are divergent views on colour harmony and the literature reveals three main approaches to this construct: Colour harmony underpinned by colour order and proportional colour selection; colour harmony arising from ‘balance’ in terms of contrasting/complementary colour; and colour harmony arising from similarity of colour attributes: hue, tonal value and chroma (saturation).

The divergent views on colour harmony can be partly explained by theorists focusing on different categories of colour as per Green-Armytage (2006): *Conventional colour* is the subjective perceptions and understanding implied by terms such as ‘red’ and ‘blue’. *Formula colour* refers to proprietary colours devised by paint, dye and industrial colour manufacturing companies, and represents specific hues defined by formula and assigned names such as ‘antique white’. *Substance colour* is colour in the form of pigments and dyes, and colour theorists who focused primarily on this category include Chevreul, Munsell, Ostwald, and Itten. *Spectral profile colour* refers to colour in the form of light waves (including computer and television monitors, human visual perception, and digital colour). Colour theorists that focused on this colour category include Newton, Goethe, and Hering.

The literature also reveals two divergent ontological assumptions that underpin colour harmony theories. The first of these suggest that a causal link exists between colour and human response which may be a function of evolutionary inheritance, and that responses to colour occur on a universal basis. This ontological approach,<sup>1</sup> which has largely been discounted, is evident in the simplistic colour response theories of Goldstein (1942) and the writings of Birren (1961, 1978).

A second ontological perspective suggests that human response to colour does not represent a cause-and-effect mechanism but may arise due to learned colour associations and culturally-acquired colour symbolism and beliefs. This ontological approach suggests that responses to colour may be context dependent, highly idiographic and therefore highly variable (as per Albers 1963, O’Connor 2008, 2010, Osgood, Suci and Tannenbaum 1975, Wise, Wise and Beach 1988).

## THE INTERFACE BETWEEN COLOUR AND HUMAN RESPONSE

The interface between colour and human response is complex and there are no ‘hard-wired’ linkages between colour and affective, cognitive and behavioural response (Wise, Wise and Beach 1988). Research indicates that there are many factors that tend to influence this interface and these include individual differences (age, gender, preference, personality, affective state, stimulus screening capacity, and so on), variations in cultural background, beliefs and experience; as well as various perceptual, contextual and temporal variations (Nasar 1994, O’Connor 2008, 2010).

In addition, Osgood, Suci and Tannenbaum (1975) suggest that responses to colour are multidimensional and are not fixed but may vary according to changing ambient conditions. The factors that influence the interface between colour and human response are illustrated in Figure 1.

---

<sup>1</sup> Ontology has to do with the nature of the lens through which a theorist views their subject of theory or research (Moore 1997). Many colour harmony theories assume a causal link between colour and positive affective response, irrespective of other intervening factors. Some colour theories are characterised by the theorists’ personal assumptions and beliefs. For example, Faber Birren was convinced that colour impacted human response and his theories and writings exhibit this ontological bias (Birren 1961, 1978).

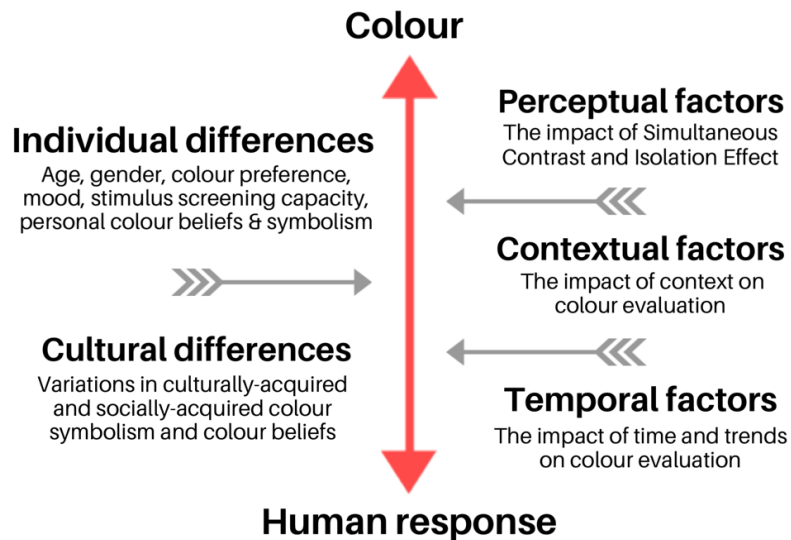

Figure 1: The factors that influence the complex interface between colour and human response.

An updated colour harmony conceptual model is proposed in response to a previously published model (O'Connor 2010). This model acknowledges the factors that impact the interface between colour and human response, and allows for a broader and more diverse range of colour strategies which address the variability of responses to colour.

$$\text{Colour harmony} = f(\text{Colour strategy } X) \times (\text{ID} + \text{CE} + \text{CX} + \text{PE} + \text{TI})$$

Under this model, evaluation of a specific colour strategy ( $X$ ) is viewed in a contextual manner as opposed to in isolation. In addition, positive response to colour is a function of individual differences (ID) such as age, gender, preference, affective state and so on; plus differences in cultural experience and background (CE) including culturally and socially-acquired colour beliefs and symbolism; plus the context (CX) in which the colour strategy will be viewed and evaluated; plus perceptual effects (PE) such as simultaneous contrast that may impact colour strategy perception and evaluation; plus, temporal impact factors (TI) such as colour trends that may influence evaluation of colour strategy. This colour harmony conceptual model allows for a range of colour strategies and it is recommended that colour strategies devised to appeal to a specific target audience or market segment are subject to evaluation by participants drawn from that cohort.

## COLOUR – A COMPLEX PHENOMENON

Colour is a complex phenomenon. It occurs across a range of manifestations and contexts, and includes pigments, dyes, substances, metallics and materials, as well as light and digital applications, semiotics, accumulated cultural beliefs and memory.

In addition, we can discern a huge range of colour nuances, estimated to be between 1.8 and ten million hue variations (Judd and Wyszecki 1975, Pointer and Attridge 1998). These estimates pale into comparison with the Hex colour coding system, a hexadecimal colour coding system that allows for 16,777,216 individual colour variations —by far the most extensive colour coding system.

Hard and Sivik (2001) acknowledged the complexity of colour and observed the “almost infinite” range of possible colour combinations (Hard and Sivik 2001: 4). Similarly, Albers also noted the

complexity of colour, leading him to assert that well-known “rules of thumb of complementaries, whether complete or split and of triads and tetrads ... are worn out” and that, in respect to the notion of colour harmony strategies, “no mechanical system is flexible enough to precalculate the manifold changing factors ... in a single prescribed recipe” (Albers 1963: 42).

Caivano (2018) recently drew attention to a broader understanding of colour that includes colour gradations and transformations, and other dimensions of colour appearance beyond the usual colour taxonomic colour divisions. Caivano notes that virtually all colour notation systems do not allow for differentiation of millions of colour nuances nor for colour gradations and transformations.

## TRADITIONAL COLOUR HARMONY GUIDELINES, RULES AND FORMULAE

The idea of linking colour harmony with order gained currency during the Age of Enlightenment. At this time, scientific inquiry focused on a search for order, which was aligned with geometric proportion and harmony in a broader sense. Newton asserted that light was composed of “the original or primary (‘prismatic’) colours ... red, yellow, green, blue, and a violet-purple together with orange and indigo and an indefinite variety of intermediate gradations” and he correlated colour, harmony and the proportions of the diatonic musical scale (Newton 1671: 3082).

Goethe advocated the notion of complementary (‘completing’) colour and he focused on colour and the mechanics of visual perception: “the eye especially demands completeness”; quoting Aristotle in this regard: “We are delighted with harmony because it is the union of contrary principles having a ratio to each other” (Goethe 1840: 60). The notion of linking ‘complementary’ colour to colour harmony was given added credence by Chevreul, whose *Principles of harmony and the contrast of colours and their application to the arts* became influential. Chevreul suggested that maximum contrast of complementary colours is equated with colour harmony.

During the late nineteenth and twentieth century, it was suggested that complementary colours combine to produce a state of neutrality in the eye and visual ‘balance’ could be achieved when pairs of opposing or contrasting colours produced a neutral grey in the retina (as per Hering 1874, cited in Hard 1975). Along with complementary colour, the notion of ‘balance’ was also aligned with colour harmony: “(Colour) harmony implies balance; symmetry of forces” (Itten 1961: 65).

Over time, prescriptive colour harmony guidelines underpinned by colour order, balance and proportional colour selection became accepted wisdom. Colour theorists such as Munsell (1921) and Ostwald (1916) devised colour harmony rules, guidelines and formulae aimed at achieving colour harmony, and advised that “colour (harmony) is order (Ostwald 1916: 24). These rules and guidelines segued into a now ubiquitous range of colour strategies that are commonly aligned with colour harmony (for example, see Sawahata and Eldridge 2007, Hornung 2012).

In respect to digital colour application, a range of colour scheme generators, apps and websites exist that include online tools aimed at creating harmonious colour schemes. These tools provide users with hue libraries and a very limited range of colour strategies based on traditional colour harmony formulae including analogous colour, monochromatic colour, contrasting/complementary colour, triadic and tetradic colour schemes. Digital colour scheme generators that feature such tools include Color Harmony Android App, Paletton and Color Supply.

The drawbacks of traditional colour harmony guidelines, formulae and online tools include: a) relatively limited range of colour strategies; b) the primary focus on hue selection; and c) a relative absence of guidelines that address or allow for a greater range of hue, tonal value and chroma variations including tertiary colours, chroma-reduced colours, metallics, and so on.

## COLOUR STRATEGIES FOR APPLIED DESIGN AND DIGITAL COLOUR

These colour strategies include traditional colour harmony guidelines and formulae drawn from the literature which have gained currency due to their ubiquity and familiarity. Additional strategies are presented which aim to appeal those whose colour preferences may extend beyond the relatively narrow confines of traditional colour guidelines. Furthermore, options are included which allow for variation of tonal value and chroma levels depending on requirements for visual cohesion, mood and ambience, focus, and contrast legibility (see Figure 2).

- 1) **Analogous colour strategy** – features hue similarity and includes colours that sit in proximity on colour wheel models. Similarity of hue contributes to visual cohesion. Variations in tonal value and chroma contribute to the creation of focus and contrast legibility.
- 2) **Contrasting colour strategy** – features contrasting (complementary) hues, which enliven each other and enhances hue intensity. Variations of tonal value and chroma levels can either subdue or enhance intensity, create focus, mood/ambience, and contrast legibility.
- 3) **Triadic ('split complementary') colour strategy** – a contrasting colour strategy, this features a key hue plus two hues drawn from either side of the key hue's contrasting colour. Variations of tonal value and chroma level subdue or enhance colour complexity, focus, and contrast legibility.
- 4) **Triadic (equidistant hues) colour strategy** – features hues drawn from equidistant positions around colour wheel models such as the common trio of red, yellow and blue; or, more unusual trio of orange, green and purple. To create visual cohesion with these disparate combinations, use similarity of tonal value and chroma levels but tweak to create focus, contrast legibility.
- 5) **Tetradic colour strategy** – features two pairs of contrasting colours as per colour wheel models. Each hue in this strategy tends to be intensified by its contrasting hue. Tonal value and chroma variations can be varied to subdue or enhance colour visual complexity, focus, mood/ambience.
- 6) **Pentadic colour strategy** – features five hues, contributing a highly colourful effect. Variations of tonal value and chroma levels need to be monitored to ensure visual cohesion and create effective focus, and avoid visual colour complexity, unless this is the aim.
- 7) **Monochromatic colour strategy** – features one hue at different tonal value and chroma levels. The monochromatic strategy has inherent visual cohesion due to similarity of hue. Variations of tonal value and chroma level can contribute to focus, contrast legibility and mood/ambience.
- 8) **Monotone colour strategy** – features different hues pegged at the same/similar tonal value. Tonal value similarity adds a sense of visual cohesion but minimises the capacity to create focus and contrast legibility. Chroma level variation adds visual variety and creates mood/ambience.
- 9) **Colour discord colour strategy** – features hues wherein the 'natural' (that is, ubiquitous or familiar) tonal value of hues has been reversed. Colour discords represent atypical, unfamiliar colour combinations. Varying tonal value and saturation adds focus, contrast legibility.
- 10) **Vibrating colour strategy** – features colours that appear to vibrate at the boundary between each colour. Colour vibration tends to occur with contrasting hues at the same chroma level and tonal value and can enhance or distract from contrast legibility.
- 11) **Darks + Brights colour strategy** – features predominantly dark toned hues in a low key, major tonal chord that is offset with hues that are lighter and appear brighter against the dark hues. The lighter, brighter hues tend to form the key focus point and support contrast legibility.

- 12) **Chroma reduction (tints) colour strategy** – features a set of hues that have been chroma reduced using white to create soft, pastel colours. High key, minor chord hues create visual cohesion based on similarity of tonal value but the scheme may lack focus and contrast legibility.
- 13) **Chroma reduction (grey) colour strategy** – features a set of hues that have been chroma reduced using grey. This ‘shadow’ colour palette has inherent visual cohesion based on similarity of the grey undertone. Variations of tonal value can create focus and contrast legibility.
- 14) **Chroma reduction (tertiary colours) strategy** – tertiary hues traditionally arise from intermixture between two secondary colours; or, one hue and its contrasting hue. Tertiary hues include earthy, less familiar and unusual hues. Tonal value and chroma variations enhance contrast legibility.
- 15) **Neutrals + Colour strategy** – features predominantly neutral or achromatic hues plus accent hues. The achromatic context allows for the selected hue to form the key focus point. Tonal value and saturation can be adjusted to enhance contrast legibility.
- 16) **Polychromy colour strategy** – features multiple hues. Tonal value and chroma levels can be varied to enhance visual cohesion, focus and contrast legibility.
- 17) **Simultaneous contrast strategy** – features a range of hues combined to create simultaneous contrast, making one colour appear to change in hue, chroma level or tonal value.
- 18) **Achromatic colour strategy** – features hues that are predominantly achromatic: white, greys, black. Tonal value variations create focus and contrast legibility.
- 19) **Warm + Cool colour strategy** – features hues associated with imagery depicting warm or cool contexts, substances or themes. Contrast of hue and tonal value creates focus, contrast legibility.
- 20) **Colour gradation colour strategy** – features colour gradations or hue transformations between two or more hues. Contrast of hue, chroma and tonal value enhance focus and contrast legibility.



Figure 2: Twenty colour strategies developed for applied design and digital colour application.

In conclusion, an updated colour harmony conceptual model is presented that responds to advances in research and ontological theoretical analysis. The model acknowledges that responses to colour are highly variable and open to the impact of a range of different factors. Twenty colour strategies are also presented, representing a larger range of colour combination guidelines and formulae currently available. These strategies allow for more diverse, variable responses to colour. They also feature foundational colour concepts and relationships that are common in the literature on colour (such as ‘primary colour’ and ‘secondary colour’); are underpinned by formulae linked to hue, tonal value and chroma levels, and are adaptable as algorithms for digital colour application.

## REFERENCES

- Albers, J. 1963. *Interaction of color*. New Haven, CT: Yale University Press.
- Birren, F. 1961. *Color psychology and color therapy; a factual study of the influence of color on human life*. New Hyde Park, New York: University Books.
- . 1978. *Color and human response*. New York: John Wiley & Sons.
- Caivano, J. L. 2018. Colour from a gradualist perspective. In: *Proceedings of the International Colour Association (AIC) Conference 2018*, Lisbon, 25-29 September 2018, M. Gamito and M. J. Durão, eds. Newtown, NSW: International Colour Association, 31-38.
- Goethe, J. W. 1840. *Theory of colours*, translated from the German by C. L. Eastlake. London: Murray.
- Goldstein, K. 1942. Some experimental observations concerning the influence of colors on the function of the organism. *Occupational Therapy & Rehabilitation* 21 (3): 147-151.
- Green-Armytage, P. 2006. The value of knowledge for colour design. *Color Research and Application* 31 (4): 253-269.
- Hard, A. 1975. NCS: A descriptive order and sacling system for environmental design. *Man-Environment Systems* 5 (3): 161-167.
- Hard, A., and L. Sivik. 2001. A theory of colors in combination: A descriptive model related to the NCS color-order system. *Color Research and Application* 26 (1): 4-28.
- Hornung, D. 2012. *Color: A workshop for artists and designers*. London: Laurence King.
- Itten, J. 1961. *The art of color*, revised edition. New York: John Wiley & Sons, 1973.
- Judd, D. B., and G. Wyszecki. 1975. *Color in business, science and industry*. New York: John Wiley & Sons.
- Moore, G. T. 1997. Toward environment-behaviour theories of the middle range. In: *Advances in environment, behaviour, and design*, vol. 4, G. T. Moore and R. W. Marans, eds. New York: Plenum Press.
- Munsell, A. H. 1921. *A grammar of color*. Accessed from [www.gretamacbeth.com](http://www.gretamacbeth.com).
- Nasar, J. L. 1994. Urban design aesthetics: The evaluative qualities of building exteriors. *Environment Behavior* 26: 377-401.
- Nemcsics, A., Z. O'Connor, and R. Pompas. 2016. Color harmony. In: *Encyclopedia of Color Science and Technology*, M. R. Luo, ed. New York: Springer, 322-328.
- Newton, I. 1671. A letter of Mr Isaac Newton, Professor of the Mathematicks in the University of Cambridge; containing his new theory about light and colours. *Philosophical Transactions of the Royal Society*, vol. XVI (179): 3075-3087.
- O'Connor, Z. 2008. *Façade colour and aesthetic response: Examining patterns of response within the context of urban design and planning policy in Sydney*. University of Sydney, PhD thesis.
- . 2010. Colour harmony revisited. *Color Research and Application* 35 (4): 267-273.
- Osgood, C. E., G. J. Suci, and P. H. Tannenbaum. 1975. *The measurement of meaning*. Urbana: University of Illinois.
- Ostwald, W. 1916. *Die Farbenfibel (The colour primer)*. Cited in J. Gage (2000) *Colour and meaning - Art, science and symbolism*. London: Thames & Hudson.
- Pointer, M. R., and G. G. Attridge. 1998. The number of discernable colours. *Color Research and Application* 23: 52-54.
- Sawahata, L., and K. Eldridge. 2007. *Complete color harmony workbook*. Gloucester, MA: Rockport.
- Wise, B. K., J. A. Wise, and L. R. Beach. 1988. *The human factors of color in environmental design: A critical review*. Moffett Field, CA: NASA Ames Research Centre, NASA Grant No. NCC 2-404, 1988.

# Local colour and patterns

**Glenn McArthur**

OCAD University, Toronto, Canada  
gmcarthur@faculty.ocadu.ca

## ABSTRACT

As the colour course leader for first-year design students at OCAD University, one of the challenges I face, as always, is to find projects and exercises that stimulate, inspire and creatively stretch students, while meeting the course outline and objectives. The “Local Colour & Patterns” project was created last year in an attempt to address this challenge and to get students to think how geographically specific colour palettes and patterns of local flora and fauna and environmental objects that can be used as a starting point in the process of creating a contemporary design that would reflect an essence of place.

This project was partially inspired by the work of French designer and colourist Jean-Philippe Lenclos, which had a focus on identifying and working with site-specific colour palettes and by the poetic sensibilities expressed in Petr Král’s 2012 publication, *In search of the essence of place*. The aim of my poster presentation that was exhibited at the AIC conference in Buenos Aires in the fall of 2019, was to highlight and showcase the final results of student’s efforts.

**Keywords:** *colour education, local colour, two-dimensional design*

## INTRODUCTION

OCAD University is the largest art-and-design-specific university in Canada and the fourth largest in North America. The first-year design student body intake is usually around seven hundred students (the art stream intake is about four hundred) majoring in the disciplines of environment, industrial, graphic, illustration, advertising and material arts and design. These students come from many different educational backgrounds and experiences and their artistic skill sets range from the novice to the exceptional in traditional and or digital media. First year students were required to take the course entitled Colour and Two-Dimensional Design, which is described in the following outline:



This course introduces students to the basic elements and principles of design and colour as well as those interactions and harmonic relationships that can be considered for two-dimensional compositions. Exercises and assignments germane to contemporary design practices focus on form generation and composition, applied vocabulary, contextual colour applications, spatial sensitivity and the development of practical two/three dimensional compositions.

The content for the course is built around the textbook that I wrote, *Colour and two-dimensional design* (McArthur 2017), and consists of twelve units, one per week. The student work-load over the semester consists of weekly online quizzes, eight exercises and two three-week projects. The first project is usually a self-portrait, where the students are instructed to conduct research into the colours that make up their world (clothing, living spaces, favorite objects, etc.). It is meant to be a self-reflective exploration of the colour palettes in their life. From this introspective research, two self-portraits are required, one with the student's favorite colour scheme and one with colours they hate. This project usually consumes the first half of the semester and for the latter half of the semester the student's second project moves them away from their inner world to a more external global theme.

## THE PROJECT

The "Local Colour & Patterns" project was my second attempt at trying to create a site-specific colour project. The first attempt asked students to travel to a particular neighborhood of their choice within the city of Toronto and identify the colours in that locale. With over fifty different ethnic communities in the city there is no shortage of local colour. Unfortunately, this was out of the comfort zone for most of our first-year students and only a few actually made the effort to physically go to a site and do a colour analysis of the local colour schemes. It appears students were uncomfortable taking local transportation to get to sites and used the internet instead to do their research. Lesson learned. The second iteration of this project as mentioned was inspired by Jean-Philippe Lenclos (2019) and informed by the failings of my first effort.

The "Local Colour & Patterns" project consisted of three phases: first, students selected a geographic location and conducted visual research on it from either the internet or, if that had visited the location, they could use their own images. To extract the colour information from the images they uploaded them to one of the many colour identification websites or used Photoshop's colour picker to create a multi-hued palette (ideally about twenty-four colours were to be selected). For the second phase, students were instructed to create a composition that was atmospheric or abstract in nature, using the colour palette they had extracted. This composition was to be used as a background for their final design. Then the students had to conduct additional research on the local wildlife, flora and fauna, built or natural forms in order to find decorative patterns or a theme from their site's local environment that would serve as the basis for a foreground design. They were instructed to allow themselves to be inspired by local conditions and then transform these inspirations into a contemporary design. For the final phase, students combined their abstract image and pattern into one design and then applied it to either a two-dimensional or three-dimensional object or surface.

## CONCLUSION

The results from this project were impressive. Normally, in any given class, the number of “A” grade project marks is about 10 to 20% of the class size or about four students (which usually suits the course’s bell curve). This project presented me with marking challenges, because the number of outstanding “A” grade work was significantly higher and in some classes was 50 to 60% or ten to twelve students. This created some interesting challenges with trying to fit these results into my marking rubric. The success of this project will ensure that it continues as one of the main semester projects in successive years and hopefully will continue to open students’ eyes to the possibility of finding inspiration in local environments.



Figure 1: Above, is the geographic location of Niagara Falls, Canada, that the student selected and on the right is the extracted colour palette from the image. Image and project credit: Karina Lee.



Figure 2: Additional visual research was conducted to identify site specific patterns or features that could be used as a source of inspiration for the composition’s foreground pattern. Image and project credit: Karina Lee.

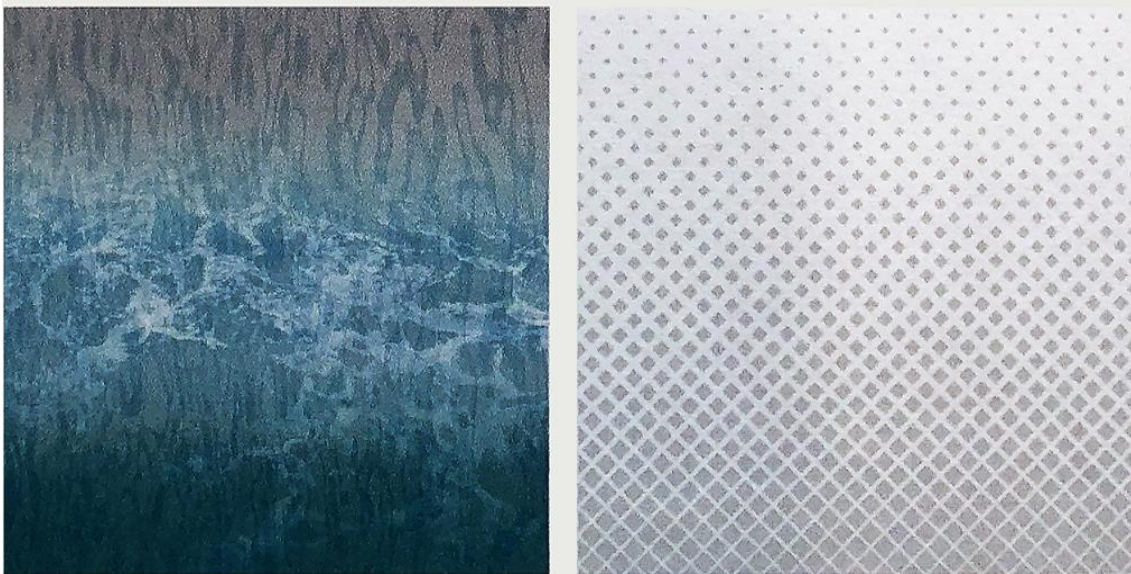

Figure 3: On the left is the background composition that was inspired by the water's texture and the patterns of the foam and ripples found at the base of the falls. On the right is the foreground pattern inspired by the rising mist from the waterfalls. Image and project credit: Karina Lee.

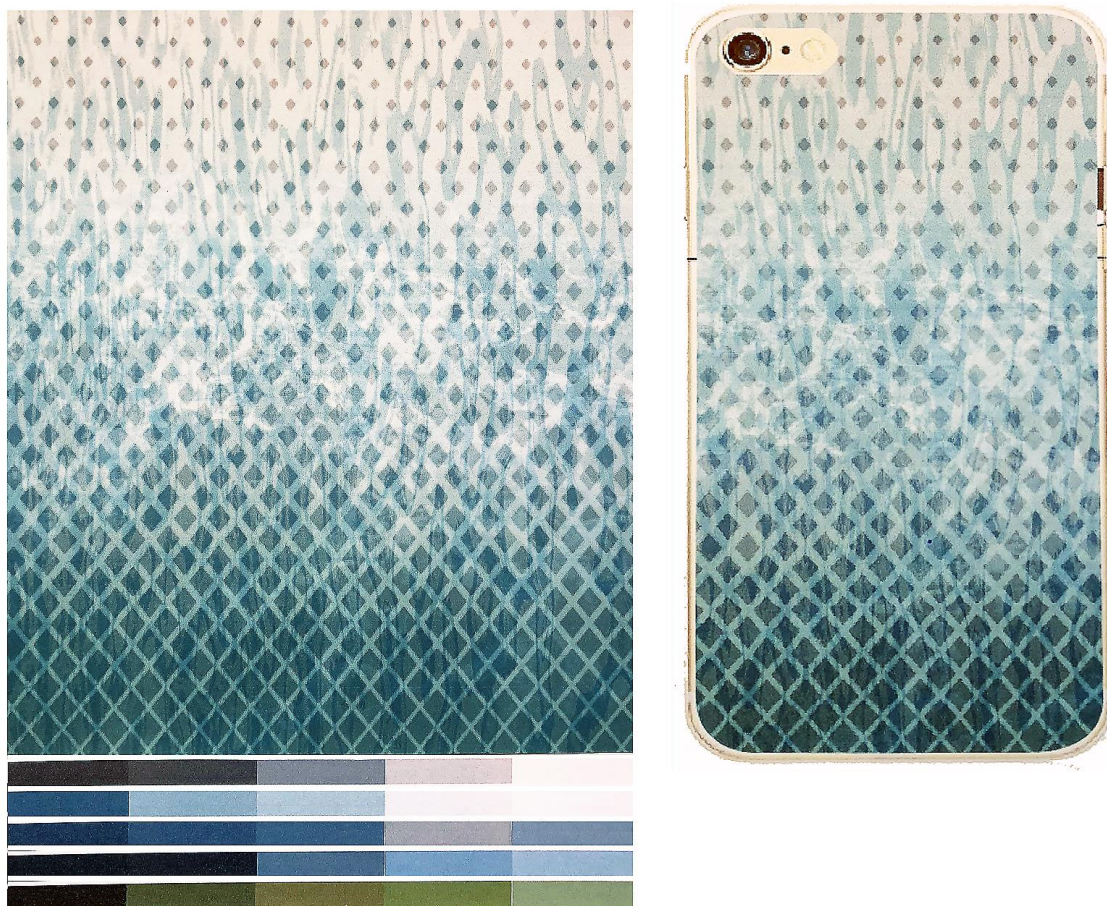

Figure 4: on the left the background design and foreground pattern are combined into a single composition with the colour palette below. On the right the design is applied to a three-dimensional object (smart phone). Image and project credit: Karina Lee.

# Local Colour & Patterns

Glenn McArthur: OCAD University, Toronto, Canada

**Objectives:** This project encouraged students to think about colour and patterns from specific geographic and cultural locations and how local colour may be used in contemporary design, evoking and celebrating the essence of a place.

This is a first year project for design students in a *Colour and Two-Dimensional Design* course. It consisted of three phases: first, students selected a geographic location and conducted visual research on it from both the internet or their own images. Next, they uploaded those images to a colour identification website and extracted the colour information. For the second phase, students were instructed to create a composition that was atmospheric or abstract

in nature, using the colour palette they had extracted, which they were then to use as a background for their final design. Additional research was conducted to find decorative patterns from their sites' local environment (plants, animals, built forms, etc.) and then transform it into a contemporary design. For the final phase, students combined their abstract image and pattern into one design and then applied it to either a 2D or 3D object or surface.

Comments? Please share any thoughts by email: [gmcArthur@ocad.ca](mailto:gmcArthur@ocad.ca) or [glennmcArthur@gmail.com](mailto:glennmcArthur@gmail.com)

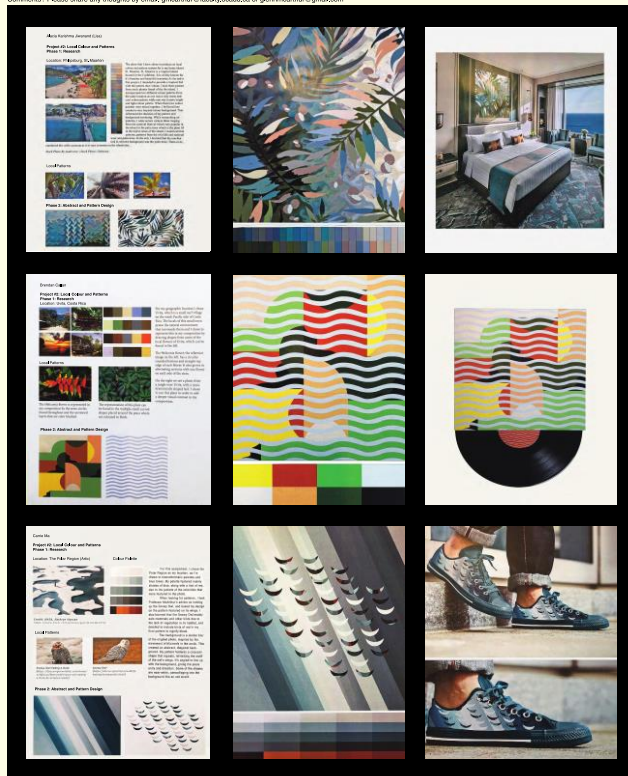

Figure 5:  
This poster was exhibited at the AIC Conference 2019 in Buenos Aires, and won one of the Robert W. G. Hunt Poster Awards (see Appendix, in this book).

## ACKNOWLEDGEMENTS

Acknowledgements must go to my first-year colour course students at OCAD University that allowed me to exhibit their projects. See list below.

Figures 1, 2, 3, 4: Local Colour and Patterns, Niagara Falls, Canada. Karina Lee, 2018.

Figure 5: First row of images: Local Colour and Patterns, Boardwalk, Philipsburg, St. Maarten; Alacia Karishma Jiwanand (Lisa), 2018. Middle row of images: Local Colour and Patterns, Uvita, Costa Rica; Brendan Callan, 2018. Bottom row of images: Local Colour and Pattern, The Polar Region (The Arctic / Antarctica); Carrie Ma, 2018.

## REFERENCES

Král, P. 2012. *In search of the essence of place*. London: Pushkin Press.

Lenclos, J.-P. 2019. *Colour Architecture*, Atelier 3D Couleur. <http://www.a3dc.paris>. Accessed: 22 September 2019.

McArthur, G. 2017. *Colour and two-dimensional design*. Toronto: OCAD University Press.

# Project work experiences in post-graduate education on color design

Maurizio Rossi<sup>a\*</sup>, Ingrid Calvo Ivanovic<sup>b</sup>, Alessandro Rizzi<sup>c</sup>

<sup>a</sup> Dipartimento di Design, Politecnico di Milano, Italy

<sup>b</sup> Departamento de Diseño, Universidad de Chile, Chile

<sup>c</sup> Dipartimento di Informatica, Università degli Studi di Milano, Italy

\* maurizio.rossi@polimi.it

## ABSTRACT

In this paper we expose some of the most significant color design experiences and results conducted in the Master Program in Color Design & Technology, organized by Politecnico di Milano in cooperation with Associazione Italiana Colore and Università degli Studi di Milano. This Master aims to provide advanced multidisciplinary training to professionals, so as to enable them to understand and manage the technological and design issues, often across many disciplinary areas, typical of all the professional and research sectors in which the use and management of color are essential. This one-year post-graduate master program consists of three main phases: the first phase is composed of lectures on color fundamentals by different academics and professionals; the second phase, which we expose here, is composed of five specialized extended workshops about Color in Communication, Fashion, Interior, Product and Urban Design. In the last phase, the students go through an Internship period, to establish contacts between the academia and companies who work with color in the field of design, architecture, textiles and paints, among others.

**Keywords:** *color theory, color science, color education, post-graduate, master program*

## INTRODUCTION

Since it has been established, one of the most remarkable characteristics of this post-graduate program has been an approach to color with a multidisciplinary attitude with regard to the teaching of contents. This master has also been promoting cross-cultural backgrounds and profiles of the students with university degrees in architecture, art history, engineering, fashion design, graphic design, industrial design and product development, interior design, psychology, visual and performing arts. In 2019 the students come from 9 different countries (Chile, France, Guatemala, Ireland, Italy, Mexico, Russia, Spain and USA). The multidisciplinary nature is emphasized in the recognition of color as a complex, multi-scale element, which can and must be addressed from different

background and know-how. Color, because of its relativity, is a place where different disciplines can be mixed and becomes an interesting challenge for designers, artists and architects professionals who works together, contributing with their different knowledge and methodologies to solve the proposed requirements.

## PROJECT WORKS ON COLOR DESIGN

The project works phase consists in a series of three-weeks workshop in which students are required to work as a team of 2 or 3 people. This teams are formed by students with different backgrounds (graphic designers, interior designers, product designers, architects and artists) in order to facilitate cooperation and complement among students and face multidisciplinary assignments. In the conformation of groups, it was also advised to gather students with different origins, embracing multiculturalism. At the begin of each project work, teachers give the guidelines for one or more assignments to be developed during the three weeks, and require a final presentation of results.

In the first project work, on Color in Communication Design, taught by teachers Lia Luzzatto and Elisabetta del Zoppo, students were introduced to the world of color language, and their possibilities to communicate and structure a visual message. They begin by establishing parallels between concepts and images, developing mental maps, where they have to link specific colors with sensations related to 'hearing', 'sight', 'touch', 'taste/smell', 'personality' and 'emotions', understanding color as a powerful meaning resource. With this information, they develop a moodboard of the different concepts in order to create a color chart and they test different color palettes to be applied in a brand they have to imagine and define. Some other exercises of this project work are related to color modification of famous brands in order to imagine a different messages, different brand personality and different target public or users. Also, as part of this project work, the students practice with the communication of colors in the different color management systems, such as RGB, CMYK, Pantone, Munsell and NCS, among others, in a final printed project of editorial design (Figure 1).



Figure 1: Project work one, color change proposal for Indian McDonald's; students S. Cares & C. Boretz.

In the second project work, on Color in Fashion Design, taught by teachers Arturo Dell'Acqua Bellavitis and Maria Grazia Soldati, students explored in the design of pattern for fashion. Through the choice of one of the different geographical regions of Italy, the students performed a brief research about the geography, architecture, image, identity and cultural elements of the specific region, with the aim of visual materials or photographs. In parallel, they explored with geometry and

gave shape to the different patterns. From the color research, they managed to create a moodboard and a set of colors to be applied in the patters. Finally, they virtually simulated the application of the different patterns to fashion objects and products, such as fabrics, clothes and accessories, in order to propose a collection. During this project work, the color and textile researcher Renata Pompas held a session of empowerment for the students, helpful to understand the color ordering inside the color books and the formal presentation of fashion collections (Figures 2, 3, and 8).



Figure 2: Project work two, color proposal for fashion patterns, based in Bologna pasta sauce; students S. Suarez & C. Ruiu.



Figure 3: Project work two, color applications in fashion patterns; students S. Ahmad & S. Camporeale.

In the third project work on Color in Interior Design, taught by teachers Lorenzo Morganti and Arturo Dell'Acqua Bellavitis, the students were ask to design a color proposal for the International Art Design Center (IADC) at Shenzhen, China. The project started with a color analysis of the context and a brief search of other design museums, labeled as 'competitors and best practices'. Then, the students had to made a visit to the Museo del Design Italiano Collection in the Triennale at Milano, from where they had to choose and analyze the color of one specific artwork and get in touch with color design of interior exhibitions. With these experiences, they structured a color proposal for IADC thinking in the visual, material and spatial dimensions. They decided color palettes for branding, interior signage, packaging, furniture for the museum interior, welcome and store desks, exterior façades and interior spaces design. They presented the proposal by the using of sketches, blueprints, photomontage and 3d renders (Figure 4).

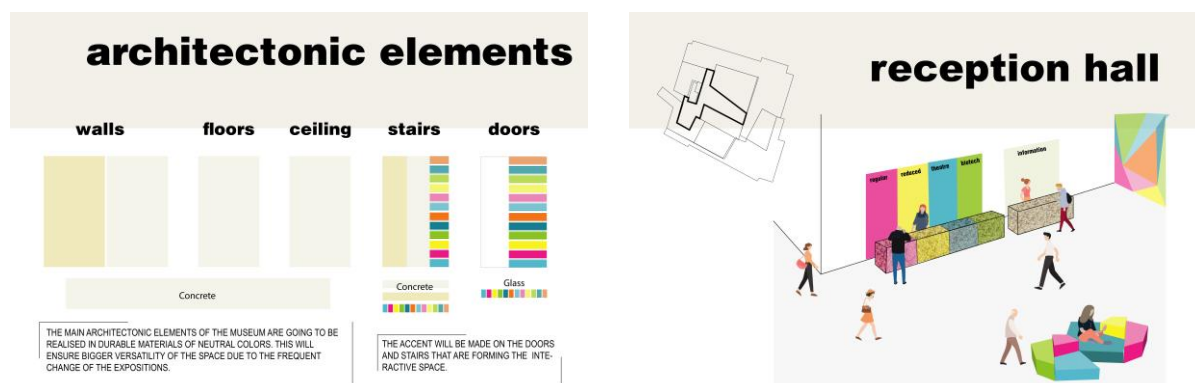

Figure 4: Project work three, color proposal for architectonic elements and application of colors in simulated reception hall of the International Art Design Center (IADC); students E. Kushnirenko & A. Pérez.

In the fourth project work, on Color in Product Design, taught by teachers Francesca Valan and Ilkka Suppanen, the students designed a collection of tableware prototypes made of wood. The project began with the analysis of references of tableware design and conceptualization. In this project work the explorations of materials and different natural colors of wood was fundamental. Then, every student had to propose the shape design and color chart and palettes for two dishes by the using of 'cold hues', 'warm hues' and finishing specifications, such as 'bright', 'opaque' and 'matte'. Finally the prototypes were industrially created and painted in ICA factory, at Milano, and are going to be presented in a final exhibition before the end of the Master program (Figures 5 and 6).

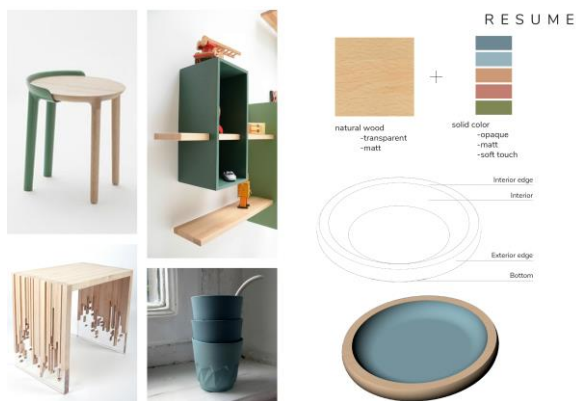

Figure 5: Project work four, color analysis of wood tableware; students S. Suárez & C. Ruii.

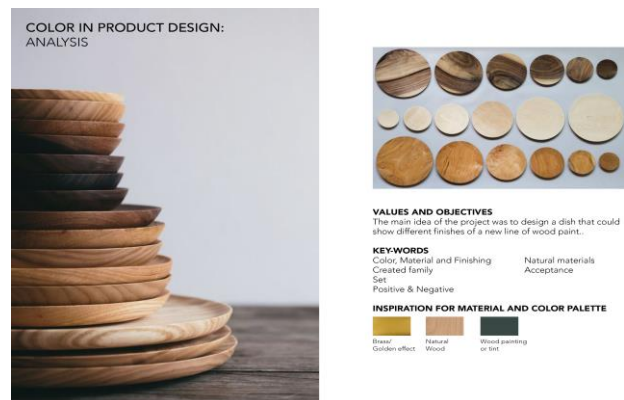

Figure 6: Project work four, color proposal for wooden objects; students S. Ahmad & S. Camporeale.

In the final project work, on Color in Urban Space, taught by teachers Aldo Bottoli and Giulio Bertagna, the students were asked to design a color proposal one of the most controversial landmarks of the Italian city of Genoa: *la Sopraelevata*, an elevated street that cuts the city heart separating the seaside from the center, running from east to west, and that runs along the coastal edge of the city, with the idea of creating a link between the water and the rest of the city; a door of continuous communication and linkage between the port and the rest of the population. The project started with an analysis to best practices in urban design in different places of the world evaluating color identity, urban furniture design, material color, integrated areas for public transportation and colored paths and pattern intervention, regarding the different needs of the proposed space, besides an exploration of the environment and historical heritage of the city of Genoa (Figure 7). Then the different proposals should consider the color design for signage, engineering structures, public and private transportation pathways, street art and pedestrian pathways. Finally, each group had to present the color concept, applications and definitions in the NCS color system.

As indicated before, each project work finished with an oral presentation of the groups, where students had to comment about the process they developed, the problems and needs they found, and the results to which they arrived (Figure 9).



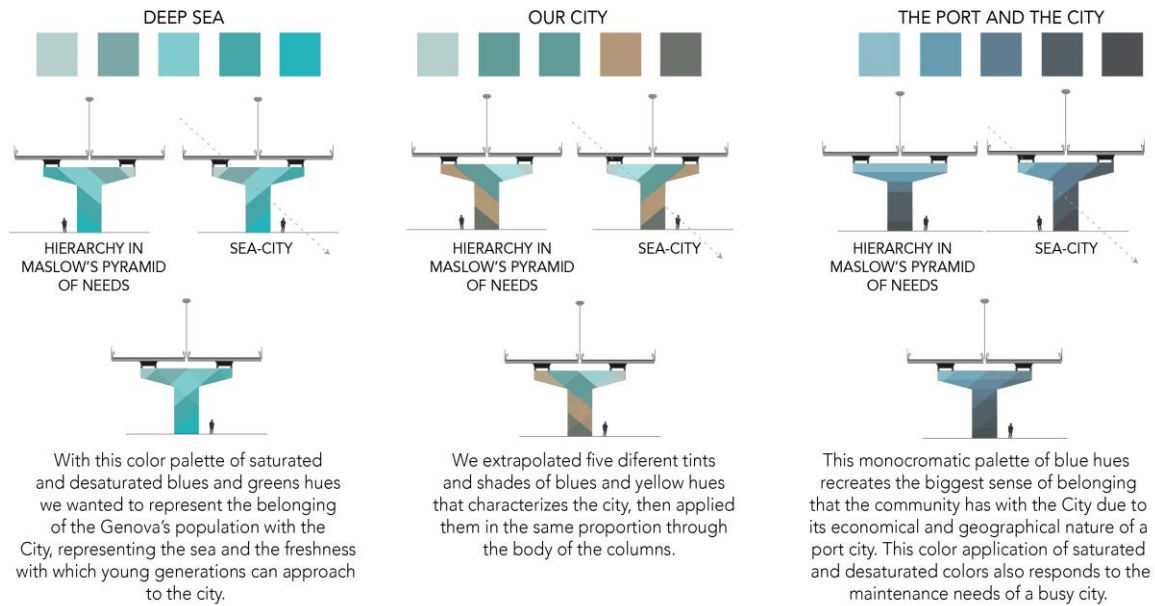

Figure 7: Project work five, color proposal for *Sopraelevata's* structural elements; students S. Suarez & C. Ruiu.



Figure 8: Color ordering in a fashion book, project work two, lesson with Renata Pompas.



Figure 9: Students S. Suárez and C. Ruiu presenting their project to classmates and teachers.

## RESULTS AND CONCLUSIONS

During the project works phase of the Master program, the students get in touch, some of them for the first time in their lives, with real color design needs, and understand color as a fundamental element of the design discipline. Color is no longer understood as a decorative element at the end of the design project, rather a key resource in order to communicate, create, intervene and change the daily lives of users. In the different assignments, the process starts with color as the main key to conceptualize and to solve the problems presented. One of the strengths of the program, which becomes evident in this phase is multidisciplinary, because for each assignment it was necessary to join the different competences of the students, contributing to the valuation of color as a complex element of architecture, design and art. In addition, the approach to color from different disciplines and real needs allows students to visualize future development possibilities for their careers, which often did not appear before on their future horizon.

## GENERAL BIBLIOGRAPHY

- Ahmad, S., and S. Camporeale. 2019. Final presentation: Project Work 4, Product Design. Presented at the Master in Color Design & Technology, Politecnico di Milano.
- Ball, P. 2003. *Bright earth: art and the invention of color*. Chicago: The University of Chicago Press.
- Berlin, B., and P. Kay. 1969. *Basic color terms; their universality and evolution*. Berkeley, CA: University of California Press.
- Bertagna, G., and A. Bottoli. 2009. *Perception design. Contributi al progetto percettivo e concetti di scienza del colore*. Rimini: Maggioli Editore.
- Borettaz, C., and S. Cares. 2019. Final presentation: Project Work 1, Communication Design. Presented at the Master in Color Design & Technology, Politecnico di Milano.
- Braddock, S. E., and M. O'Mahony. 1999. *Techno textiles: revolutionary fabrics for fashion and design*. London: Thames & Hudson.
- Fletcher, A. 2004. *Beware wet paint*. London: Phaidon Press.
- Goethe, J. W. 1810. *Theory of colours*, translated by C. L. Eastlake. London: John Murray, 1840.
- Kushnirenko, E., and A. Pérez. 2019. Final presentation: Project Work 3, Interior Design. Presented at the Master in Color Design & Technology, Politecnico di Milano.
- Lefteri, C. 2001. *Plastics - materials for inspirational design*. Hove, East Sussex: Rotovision.
- Rossi, M. 2016. Colour education: a basic methodology and a framework of experiments for colour and lighting design teaching. In: *AIC 2016 Interim Meeting "Color in Urban Life: Images, Objects and Spaces"*, *Book of Proceedings*, Santiago de Chile, 18-22 October 2016, I. Calvo Ivanovic, ed. Santiago de Chile: Asociación Chilena del Color, 239-243.
- Ruiu, C., and S. Suarez. 2019. Final presentation: Project Work 5, Urban Space. Presented at the Master in Color Design & Technology, Politecnico di Milano.
- Valan, F. 2012. The evolution of colour in design from the 1950s to today. *Journal of the International Colour Association* 8: 55-60.

# Fundamentals of color teaching in post-graduate education

Alessandro Rizzi<sup>a\*</sup>, Alice Plutino<sup>a</sup>, Maurizio Rossi<sup>b</sup>

<sup>a</sup> Dipartimento di Informatica, Università degli Studi di Milano, Italy

<sup>b</sup> Dipartimento di Design, Politecnico di Milano, Italy

\* alessandro.rizzi@unimi.it

## ABSTRACT

In this research we present a framework on the theory of color culture and science education in the context of a master program in Color Design & Technology organized in Italy since 2014. The master is organized in three main phases: Fundamentals, Project Work and Internship. The first phase is composed of lectures and theoretical lessons that gives the students a base from theory and technique, relating to disciplines such as physics, optics, colorimetry, psychology and perception. Fundamentals give all the base knowledge that the students are then asked to integrate in the project works, to propose and develop color projects for different design assignments, and in the Internship, that establish a link between the academia and companies who work with color in various fields like design, architecture, textiles and paints. Here the Fundamentals will allow the students to build up their future professional experience in the chosen field.

**Keywords:** *color design, color education, post-graduate education, multidisciplinary teaching*

## INTRODUCTION

The Specializing Master in Color Design and Technology, held in collaboration with Associazione Italiana Colore and Politecnico di Milano, aims to provide advanced training to professionals, to enable them to understand and manage the many technological and design issues, across many disciplinary areas. In fact, in many different industrial and professionals sectors the use and management of color is fundamental.

In the master's program the students have the possibility to face with different areas where color is an issue, like fashion, advertisement, product design, architecture, entertainment and urban planning. In this context color is not considered as a simple attribute of objects, but as a mean of expression and design useful to communicate, transmit messages and interact with the reality. Particular attention will be paid to color perception, from a physiological point of view, but also from a psychological and emotional ones.

This post-graduate master is organized in three main phases, the Fundamentals, the Project Work and the Internship. The first phase focuses on the theory to train students on the technical aspect of measurement, reproduction, comparison and design of colors, employing disciplines like physics, optics, colorimetry, chemistry, psychology and perception. The second phase focuses on the practical application of the methods learned during the lessons on different areas like interior design, urban spaces, industrial products, fashion and communication. At the end of the Fundamentals and Project Work, the students have the possibility to work in strict contact with professionals during the internship phase.

In this work we want to focus on the Fundamentals, that are dedicated to developing basic skills in terms of the theories, methods and tools of color design.

The Fundamentals are frontal lessons divided in four main subjects that are the bones of color consulting: History and perception of color, Colorimetry and color systems, Digital color and Color applications. The lessons are held by specialists, professionals and academics who provide contributions in the research and application of color perception and design.

## **FUNDAMENTALS**

The Fundamentals are organized during the first three months of the master giving to the students the possibility to face with all the different purposes of colors study and to see all the applications in heterogeneous domains.

At the beginning, we present the theme of color from a physical point of view, as electromagnetic radiation, and we show application on how the light interacts with different materials. Hence, we link the study of the physics of colors with material diagnostic and pigment/colorants characterization. Considering the analysis of the materials some lessons are dedicated to the chemistry of colors and to them contributes also the experience of some of the biggest producers of varnish for interior/exterior design.

The study of the materials is combined with lessons about the psychology of color and color naming. Different experts from those fields are called to teach the bond between color, culture, linguistic and psychology. In this context, the multicultural environment deriving from students coming from different countries and nations turns on the class discussion increasing the learning ability.

A particular attention is given to light and light design in the process of formation and valorization of color. Experiments are set up in the classrooms and the students in first person have the possibility to learn how to use different instruments for light measurements and to understand how the lights asset can change the perception of colors.

During the Fundamentals the students have the possibility to interact with experts in design application such as jewelers, fashion designer and interior designer, but also to discuss about copyright and law, and to discover how to manage the digital color for advertisement or film restoration (Figure 1).

The Fundamentals are composed by four main didactic units: History and perception of color, Colorimetry and color systems, Digital color, and Color applications.

## History and perception of color

“What is color for you?”. This is one of the first question that we make to our students and it is one of the hardest to answer. We are surrounded by colors and for us them have strong emotional, cultural and symbolic valence, since the antiquity. Colors are used to provoke emotions or highlights actions and messages. Due to this it is important to understand and learn what is a color. In this module the study of color is presented starting from an historical, social and artistic point of view and then the aspect of visual perception is investigated (Ball 2003, Rossi 2016). The perceptual mechanisms that affect the color and vision in general will be examined and understood in order to enable the student to recognize, anticipate and design them (Hoffman 2009).

Furthermore, students learn also the basis of color naming in different cultures and through the history, to better understand the development of the culture of color in different world area and in the civilization process (Berlin and Kay 1969).

## Colorimetry and color systems

We use to define this module as “the mathematical side of color”, because it is dedicated to the color physics, chemistry and optics (Wyszecki and Stiles 2000). Despite the cultural and subjective characteristics of color studied during the first module, colorimetry is a fundamental means to manage and communicate color. It allows to measure, standardize and represent colors in an accurate way. Here we present the basis of physics of color formation, starting from the electromagnetic radiation to notion of matter-light interaction, then the basis of perception and colorimetry are presented (Oleari 2008). In this module, students learn the main difference between different color modes and color spaces and the methods to calculate color differences.

To the students are presented the main color systems in use among science, arts and industry like Munsell, Pantone, NCS and RAL. This module allows the student to manage the basis of color design and gives them the essential skills that are at the base of color design techniques.

## Digital color

Nowadays for color managers, colorists and color designer it is fundamental to face with new technologies and to be able to control color physically and digitally. This module provides the theoretical and practical fundamentals to manage, view and reproduce digital color in different media. At first the students learn what is a digital color and how digital devices reproduce it, notions of color calibration, characterization and gamut are given (McCann and Rizzi 2011). The module provides a comprehensive knowledge of the processing chain and digital reproduction, with particular attention to the limits and the issues associated with the use of different color profiles (Ramanath et al. 2005).

In addition, students are given the possibility to make different application of color correction and color grading for advertisement or artistic purpose, facing with the great potentials that the digital means offers.

## Color applications

The module of color application is spread all along the Fundamentals lessons and gives to the students the possibility to learn from experts, professionals and artists from different fields like architecture, jewelry, interior design, photography and many others.

Color applications aims to provide the students with consciousness of color choices based on experience, preparation and diligence. In this module different examples and case studies are provided from different contexts like marketing, visual communication, restoration of cultural heritage, film and more. The aim of this module is to show how the knowledge acquired in the previous modules can be applied in most professional fields and applications (Braddock and O'Mahony 1999, Fletcher 2004, Lefteri 2001).



Figure 1: Pictures taken during the Fundamentals.

## CONCLUSION

In this paper we have presented the structure of the first part of the Master in Color Design and Technology and we have demonstrated the importance to give to the students a multidisciplinary base knowledge to face with professionals and experts.

At the end of this specializing master, students will be able to professionally manage different aspects of color thanks to the interdisciplinary nature of the course. The professional figure resulting from is widely demanded by the market, with advanced technical and design skills concerning color use and control and color design in research and in several sectors.

## REFERENCES

- Ball, P. 2003. *Bright earth: art and the invention of color*. Chicago: University of Chicago Press.
- Berlin, B., and P. Kay. 1969. *Basic color terms; their universality and evolution*. Berkeley, CA: University of California Press.
- Braddock, S. E., and M. O'Mahony. 1999. *Techno textiles: revolutionary fabrics for fashion and design*. London: Thames & Hudson.
- Fletcher, A. 2004. *Beware wet paint*. London: Phaidon Press.

- Hoffman, D. 2009. The interface theory of perception: natural selection drives true perception to swift extinction. In: *Object categorization: computer and human vision perspectives*, S. Dickinson, A. Leonardis, B. Schiele, & M. Tarr, eds. Cambridge, UK: Cambridge University Press, 148-166.
- Lefteri, C. 2001. *Plastics - materials for inspirational design*. Hove, East Sussex: Rotovision.
- McCann, J., and A. Rizzi. 2011. *The art and science of HDR imaging*. New York: John Wiley & Sons.
- Oleari, C. 2008. *Misurare il colore*. Milan: Hoepli.
- Ramanath, R., W. Snyder, Y. Yoo, and M. Drew. 2005. Color image processing pipeline. *IEEE Signal Processing Magazine* 22 (1): 34-43.
- Rossi, M. 2016. Colour education: a basic methodology and a framework of experiments for colour and lighting design teaching. In: *AIC 2016 Interim Meeting "Color in Urban Life: Images, Objects and Spaces"*, *Book of Proceedings*, Santiago de Chile, 18-22 October 2016, I. Calvo Ivanovic, ed. Santiago de Chile: Asociación Chilena del Color, 239-243.
- Wyszecki, G., and W. S. Stiles. 2000. *Color science: concepts and methods, quantitative data and formulae*, 2nd ed. New York: John Wiley & Sons.

# Environmental Color Design





# The French period in the history of environmental colour design

Verena M. Schindler<sup>ad\*</sup>, Yulia A. Griber<sup>bd\*</sup>, Martine Bouchier<sup>c</sup>

<sup>a</sup> Art and Architectural Historian, Zollikon, Switzerland

<sup>b</sup> Smolensk State University, Smolensk, Russia

<sup>c</sup> École nationale supérieure d'architecture de Paris-Val de Seine, France

<sup>d</sup> Co-Chair of the AIC Study Group on Environmental Colour Design

\* ecd.studygroup@yahoo.com, y.griber@gmail.com

## ABSTRACT

Until now, there has been little research in the vast, diverse literature on environmental colour design that is devoted to the important French period as a comprehensive artistic phenomenon. Moreover, there has not been any study of the influence of the ideas of the French colour consultants and designer colourists on the tradition of environmental colour design. The present paper addresses this lack. A qualitative oral history approach was used to conduct a series of semi-structured interviews with six French colour consultants: Bernard Lassus, Michel Albert-Vanel, André Lemonnier, Jean-Philippe Lenclos, Yves Charnay, and Victor Chérubin Grillo. Applying an inductive approach and implementing a 'thematic analysis' for the interpretation and representation of the interview data revealed key spiritual, intellectual, philosophical influences on these colour consultants as well as their sources of inspiration, teachers, and mentors, uncovering a heritage which has already left an indelible mark on the history of environmental colour design.

**Keywords:** *environmental colour design, colour consultant, designer colourist, colour methodology, French context*

## INTRODUCTION

The term 'environmental colour design' came into being relatively late in the 1940s. It was invented in response to a new reality in which increasing attention was being paid to how human activities interact with colour and associated natural factors, e.g., geographical, solar, climatic, etc. Two tendencies were crucial to the development of the term. On the one hand, through various trends, colour was considered to play a significant role in the architectural and urban environment. For example, the Art Deco movement at the turn of the 19<sup>th</sup> century combined materials and colours to meet new technological and social demands; while through Expressionism, De Stijl, the Bauhaus, and Modernism, light, openness, and simplicity were introduced into architecture as fundamental qualities. On the other hand, starting in late 19<sup>th</sup> century Europe, cognitive and experimental

psychology induced a wave of interest in the visual language and psychological meaning of colour and colour associations. Experimental psychology became a scientific field of research and colour was part of it. The arts contributed substantially to the search for the meaning of colour. In the early 20<sup>th</sup> century, Bruno Taut and Le Corbusier —two prominent architects, who also were dedicated to painting— developed a conscious and thorough application of colour in architecture and considered colour a powerful means to modify interior and exterior environments.

In the 1950s and 1960s, colour designers in France began to develop colour concepts not only for one single building or an interior space, but also for residential developments, new towns, city districts, and also for industrial buildings, public spaces, and infrastructure. Colour was applied at a monumental scale with supergraphics visually widening, distorting, or enhancing spaces and volumes. Colour provided a new dynamic and movement to environments. This understanding has shaped the Postmodernist city and has also had a significant impact on the development of environmental colour design in the sense that it sparked the birth of a new profession —the colour consultant. In collaboration with architects, engineers, town planners, industrialists, or commissioned for specific projects by public or private companies or governmental agencies, the colour consultant has become part of a multidisciplinary team (see, e.g., Prieto 1995, Caivano 2006, Schindler 2012, Jean-Philippe Lenclos 2017).

Various renowned colour consultants working in France have left an indelible mark on the history of environmental colour design: Jacques Fillacier, Georges Patrix, Fabio Rieti, Bernard Lassus, André Lemonnier, Jean-Philippe Lenclos, Michel Cler and France Cler, and Victor Grillo among others. Their influential colour projects and research have addressed colour for new buildings, historical city centres, and local or regional urban landscapes. Works of these colour experts are included in the Centre Pompidou's collection and have been exhibited in two group shows: *Environnements polychromes* in Paris (2011-2013) and *Éloge de la couleur* in Roubaix (2017). As well, their theoretical insights and practical approach to colour, often published in books, professional magazines, and newspapers, have been crucial to environmental colour design, colour research, and colour education in the arts and architecture. In the vast and diverse literature on environmental colour design, however, there hasn't been any research devoted to this important French period as a comprehensive artistic phenomenon. Moreover, there has been no study of the influence of the ideas of the French colour consultants and designer colourists on the tradition of environmental colour design. The present paper addresses this lack.

## RESEARCH METHOD

### 1) Data-gathering technique

Following a qualitative oral history approach, a series of semi-structured interviews was conducted with six French colour consultants. This data-gathering technique was especially valuable because it made it possible to explore subjective viewpoints (Flick 2009) and gather in-depth accounts of the experience of persons who have contributed to the history of environmental colour design. The semi-structured interviews focused on questions that facilitated conversation about the interviewee's life experiences relating to a particular historical event or period. These relatively unstructured interviews not only allowed the interviewees enough space to answer on their own terms, but also at the same time provided a framework for making cross comparisons (cf. Edwards and Holland 2013).

## 2) Topic guidelines

The topic guidelines for the interviews included five groups of exploratory, open-ended questions:

- 1) What has had a significant spiritual, philosophical, intellectual influence on you? What has been a source of inspiration?
- 2) Who taught you how to work with colour?
- 3) Who are your successors using your ideas? Do you have successors of whom you are proud? Do you have successors from abroad?
- 4) What does environmental colour design mean to you? How do you see the evolution of colour in the environment?
- 5) How do you prefer to practice colour?

In addition, the scheduled interview included an introduction that involved ensuring that the participants were aware of the purpose of the research; allowed the interviewees to give their informed consent; and, verified that they agreed with having the interview recorded. The interview guidelines that were employed enabled the researchers to address a defined topic while allowing the interviewees enough leeway to answer on their own terms and discuss issues pertinent to them (Choak 2012). Within the parameters of each of the pre-determined interview topics, any responses could be followed up if necessary with supplementary questions.

## 3) Participants: recruitment and sampling

As is often the case in qualitative research (see, e.g., Edwards and Holland 2013), the sample, i.e., properties and categories of the interview data, was constructed as the research progressed. Handling the interview data through 'sampling' relied on the grounded theory approach as developed by Glaser and Strauss (1967). Selection of interviewees was based on the nature and design of the study, the aims and research questions, as well as on the relevance to the theory of environmental colour design.

Interviews were conducted with the following six French colour consultants:

- 1) Bernard Lassus (b. 1929), landscape architect and visual artist, with a major solo exhibition *Jardin monde* (2017) at the Centre Pompidou.
- 2) Michel Albert-Vanel (b. 1935), colour designer, inventor of the Planetary Colour System, Professor Emeritus EnsAD, and author of many books on colour.
- 3) André Lemonnier (b. 1937), painter, colour visual artist, colour researcher, inventor of patented colour tools and atlas, and colour designer for architecture and industry.
- 4) Jean-Philippe Lenclos (b. 1938), colour designer, painter, Professor Emeritus EnsAD, colour researcher, and creator of the concept 'The Geography of Colour'.
- 5) Yves Charnay (b. 1942), visual artist, painter, creator of a patented colour-light device, designer of light installations, author, and Professor Emeritus EnsAD.
- 6) Victor Chérubin Grillo (b. 1944), visual artist, colour designer for architecture and industry, Professor Emeritus École Nationale Supérieure d'Arts de Paris-Cergy.

All inherently interested in the research project, the interviewees live and work in France and have already made a substantial contribution to the history of environmental colour design.

## 4) Planning and conducting the study

The interviews were conducted and video-recorded in May 2019 at the homes or studios of the interviewees. Each individual interview lasted from forty to ninety minutes. Participants were offered breaks in between the interview questions to allow the interviewee time to collect his thoughts. One

sample, i.e., session, included several of the invited colour consultants and thereby entailed multiple interviews yielding considerably more data than a single, snapshot study.

## RESULTS AND DISCUSSION

### 1) Data analysis

The first step of the data analysis was to transcribe the video recordings so that the material was easier to work with. As researchers, we transcribed all the data ourselves and took notes at the same time as a useful step in becoming familiar with and immersed in the data. All levels of detail were included, not only words, but also phatic utterances, pauses, and intonations.

Applying an inductive approach and implementing a ‘thematic analysis’ for the interpretation and representation of the interview data, patterns within the data were identified and studied from a constructivist methodological position to deduce the meaning that the interviewees attached to their experience, the significance this has had for their lives, and, more broadly, their own particular social construction of this influence (see, e.g., Evans 2017).

### 2) Impact of spiritual, philosophical, intellectual influences and sources of inspiration

As expected, each of the interviewees indicated unique spiritual, philosophical, intellectual influences and the sources of inspiration that have had an impact on their understanding of colour.

**Bernard Lassus** told us that he did not have any influential spiritual, philosophical, intellectual teachers and that his source of inspiration was his own work, or rather, the questions he raised and goals he set himself.

Responding to the question about spiritual, philosophical, intellectual influences, **Michel Albert-Vanel** mentioned Jean Bernard, a stonecutter and member of the *Compagnon* (French organization of craftsmen and artisans dating from the Middle Ages), who in 1941 in Lyon founded the journal *Compagnonnage*, reimagining the tradition of the worker association or ‘brotherhood’ of *Compagnonnage du Devoir et du Tour de France*, a fellowship which included taking a tour (*Tour de France*) as a journeyman to complete various apprenticeships with masters. In the context of the formation of the theory and practice of environmental colour design, Albert-Vanel’s reference to Bernard as an influence was completely unexpected. As researchers, we asked Albert-Vanel to explain exactly how Bernard might have influenced his ideas about colour. It turned out that Bernard was like a second father for Albert-Vanel, because Albert-Vanel’s mother and Bernard’s wife were very close friends. J. Bernard was son of painter Émile Bernard (1868-1941), who also did sculpture and woodcuts and whose work can be admired today at the Musée d’Orsay. Attributing great importance to colour, J. Bernard had a large studio in Neuilly where he painted. Taking Albert-Vanel under his wing, J. Bernard played an important role in developing Albert-Vanel’s taste for colour. Other influences impacting Albert-Vanel’s own development include Marcel Gromaire (1892-1971), André Pierre Léon Arbus (1903-1969), and even Mahatma Gandhi, as he describes, “...not directly, but somehow because he lived in the mental sphere.” As well, important sources of inspiration for Albert-Vanel are Buddha and Buddhism.

**Jean-Philippe Lenclos** stated that his understanding of colour was mostly influenced by artists: Claude Monet (1840-1926), Pierre Bonnard (1867-1947), Henri Émile Benoît Matisse (1869-1954), Paul Klee (1879-1940), and Sonia Delaunay (1885-1979). Each of these painters affected his theory and work in their own way. From Monet he learned about an emotional, intuitive use of colour; Bonnard’s freedom, creativity, and special ability to apply colour in combination with light impressed

him; Matisse's art of combining colours and using colour contrasts served as a powerful example; Klee's development of reflecting theoretically in an encompassing way strongly influenced him as well as the artist's creative use of colour and skilful manner of expressing feelings through colour; and, finally, Delaunay played a special role in shaping his attitude to colour: she was an artist who not only had amazing talent and intuition concerning colour, but also achieved impressive results in various practical applications, e.g., in painting and also in the design of artefacts for everyday life such as in fashion and interior decoration. Furthermore, the way she did it —perceiving colour as a part of the human environment— is of great importance to Lenclos.

The most important philosophical, intellectual influence for **André Lemonnier** is Michel-Eugène Chevreul (1786–1889), a great scholar and organic chemist who developed his own colour system that significantly shaped certain movements in painting including Impressionism, Neo-Impressionism, and Cubism. The most substantial source of inspiration for Lemonnier is the cosmos.

Reflecting on his foremost influences and sources of inspiration, **Yves Charnay** said that he cannot single out any specific person: “There is not one person, but there was a set of people, there was also a system of references from reading, from experiments, and also from encounters and conferences.” Colour came to his life more through coloured light than through painting, and also when he discovered the world of colours in the reproduction processes used in printing factories.

**Victor Chérubin Grillo** clearly identifies two major influences on his understanding of colour. First of all, there is the work of philosophers: Baruch Spinoza (1632-1677), Vladimir Jankélévitch (1903-1985), Gaston Bachelard (1884-1962), Michel Serres (1930-2019), and Michel Onfray (b. 1959). Secondly, he mentioned artists who have influenced his understanding of colour: Mark Rothko (1903-1970), a prominent representative of Abstract Expressionism and one of the creators of the Colour Field Painting movement; Caspar David Friedrich (1774-1840), a German Romantic landscape painter; and, Piero della Francesca (c. 1415-1492), an Italian painter and theorist of the Early Renaissance.

### 3) Teachers and mentors

When asked about teachers, almost all the interviewees noted that in the art schools where they studied (e.g., at the School of Decorative Arts, EnsAD, in Paris), although colour was discussed, there wasn't any specialized teaching or courses as such, as described by Jean-Philippe Lenclos, “We touched a little the subject of colour by realizing a chromatic circle that was the basis of our reflection and the learning of colour.”

Interviewee	Teachers and mentors
Bernard Lassus	Fernand Léger (1881-1955), François Desnoyer (1894-1972), Pierre Francastel (1900-1970), Léon Gischia (1903-1991)
Michel Albert-Vanel	Marcel Gromaire (1892-1971)
André Lemonnier	Jacques Fillacier (1913-1986)
Jean-Philippe Lenclos	Johannes Itten (1888-1967)
Victor Chérubin Grillo	Jean Prouvé (1901-1984), Jacques Bertin (1918-2010), Alain Wisner (1923-2004), Roger Tallon (1929-2011)
Yves Charnay	Jacques Fillacier (1913-1986), Claude Weisbuch (1927-2014)

Table 1: Teachers and mentors of the interviewees.

The list of teachers and mentors mentioned by the interviewees includes representatives of different epochs and fields (Table 1). These are not only artists and designers, but also include philosophers, writers, architects, urban planners, ergonomists, psychiatrists, and sociologists. Interestingly only one name in this list of teachers occurs twice: both Lemonnier and Charnay mention Jacques Fillacier, with Lemonnier referring to him as a 'great pedagogue'.

## CONCLUSION

In general, this study provides depth and detail to a broad schema or general picture of the history of environmental colour design, a sketch which has great potential for further development. The present research contributes to our understanding of theoretical, conceptual, and methodological approaches to the study of colour in urban space as well as to our understanding of key aspects of the evolution of environmental colour design. Representatives of the first generations of French colour design embody unique experience and knowledge, whose value will increase over time: If this heritage had not been collected and analyzed now, much would have been lost forever. A paper on some aspects of the present research has also been presented at the First Russian Congress on Colour, which took place on 18-20 September 2018 at Smolensk State University.

## ACKNOWLEDGEMENT

The interviews that were conducted are part of a broader project that examines the French period in the history of environmental colour design. The project is funded by the Mechnikov Program of the Embassy of France in Moscow.

## REFERENCES

- Caivano, J. L. 2006. The research on colour in architecture: brief history, current developments, and possible future. *Color Research and Application* 31 (4): 350-363.
- Choak, C. 2012. Asking questions: Interviews and evaluations. In: *Research and research methods for youth practitioners*, S. Bradford and F. Cullen, eds. London: Routledge, 90-112.
- Environnements polychromes*. 2011-2013. Group show as part of the exhibition 'Contemporary collections: from the 1960s to the present,' Centre Pompidou Paris, Level 4, Hall 16.
- Edwards, R., and J. Holland. 2013. *What is qualitative interviewing?* London: Bloomsbury.
- Éloge de la couleur*. 2017. Catalogue. An exhibition on the occasion of the 40<sup>th</sup> anniversary of the Centre Pompidou. Roubaix: La Piscine – Musée d'art et d'industrie André Diligent.
- Evans, C. 2017. *Analysing semi-structured interviews using thematic analysis: exploring voluntary civic participation among adults*. Thousand Oaks, CA: SAGE Publications.
- Flick, U. 2009. *An introduction to qualitative research*. London: SAGE Publications.
- Glaser, B. G., and A. L. Strauss. 1967. *The discovery of grounded theory: strategies for qualitative research*. Reprint 2006. New Brunswick and London: Aldine Transactions.
- Jean-Philippe Lenclos: painter and designer*. 2017. Jinan: Shandong Publishing.
- Prieto, S. 1995. The colour consultant: a new professional serving architecture today in France. *Color Research and Application* 20: 4-17.
- Schindler, V. M. 2012. *Polychrome Environments at the Centre Pompidou in Paris: the work of France and Michel Cler, architect-colour consultants*. *Óbuda University e-Bulletin* 3 (1): 325-337.

# Chromatic identity of urban historical settings: chromatic typology analysis

Natalia Naoumova<sup>a\*</sup>, Maria Cristina Dias Lay<sup>b</sup>

<sup>a</sup> Federal University of Pelotas (UFPel), Pelotas, RS, Brazil

<sup>b</sup> Federal University of Rio Grande do Sul, Porto Alegre, RS, Brazil

\* naoumova@gmail.com

## ABSTRACT

An improvement of the visual image of the city, aiming at restoration and conservation of its identity, requires, among other tasks, an elaboration of specific coloring strategies. This work proposes a methodology of analysis of urban polychromy based on the concept of chromatic typology, which is considered as an active element in formation of the site identity. The underlying study was performed in four Brazilian cities in the state of Rio Grande do Sul - Pelotas, Piratini, Jaguarão and Bagé. The results of coloring definition for three partially overlapped historical periods (colonial, eclectic and pre-modern) confirmed the feasibility and validity of the proposed methodology. In addition, the study made it possible to identify the chromatic preferences of inhabitants of historical areas. In this way, the research reveals constant and innovative chromatic components and, therefore, creates references to guide possible interventions in historical areas at urban scale.

**Keywords:** *color scheme, urban polychromy, historical heritage, environmental perception*

## INTRODUCTION

Any historical center, due to its formal evolution over the years, has a certain morphology and spatial structure, with peculiar characteristics of the ambiances formed by specific sets of buildings, streets and squares, which provide different types of perception through their physical appearance. The urban polychromy incorporated in this context provokes several visual phenomena, suggesting a series of interpretations of formal and symbolic elements, which result in a specific perception by each person.

Evaluated in the context of a complex environment subject to continuous changes, the historical areas trigger the same ambiguity from the beginning. On hand, they include the historical buildings of various styles, whose treatment requires a balance among the painting patterns adequate to the different historical styles and, on the other hand, one cannot ignore that these buildings are placed in the living environment of the city (Norberg-Schulz 1980).

Spontaneous development of polychromy (through the repainting of buildings) leads to the creation of new painting rules and standards of adjustment, which cause the inevitable transformation of the aesthetic perception of historical areas. The majority of specialists in the area agree that, in order to perform the effective conservation of urban heritage, specific colors based on the historical content should be used (Aguiar 2005). However, the perception and evaluation of different chromatic building attributes by inhabitants have rarely been considered for urban planning decisions. An adequate introduction of aesthetic considerations (coherent with chromatic identity) in the study of colors makes it possible to turn the public places of the historical areas more pleasant for local residents.

Stamps (1989, 2000) has gathered enough evidence to assert that carefully arranged urban environments attract people and make them feel better: this is a necessary condition to maintain these places alive and safe. One of the important elements of these arrangements is the use of colors. Therefore, it is essential to describe colors in buildings of different languages and styles and also to evaluate their visual impact by inhabitants. These procedures make it possible to perform chromatic adjustment according to both aesthetic preferences of the current residents of the historical areas and adequate visualization of the buildings in heterogeneous urban context.

To reduce the subjectivity of color choice in historical buildings, in this study we search for more objective criteria for the definition of painting schemes. To this end, we propose the methodology of urban polychrome analysis through a chromatic typology concept. We show the viability of this methodology, which allows us to determine the coloring characteristics of buildings in different periods of the past and to reveal their aesthetic evaluation according to actual perception of color schemes by inhabitants. In this way, we show the relationship between historical and current chromatic identity of urban setting.

## **EXPERIMENTS**

The definition of the chromatic typology is based on the notion of typology proposed by Norberg-Schulz, considered to be intrinsic to place identity. According to this author, the places (and consequently the buildings and their paintings) are not an infinite sequence of different cases, but a limited universe of identifiable similar models and schemes (Norberg-Schulz 1984). In this study, the chromatic typology is defined as a result of interaction between morphological characteristics of historical constructions and their colors, as well as a union of formal and chromatic aspects, which are considered to be typical for each analyzed historical period and style. This concept is applied to both historical and perceptual aspects of painting of buildings. Based on the statements advocated in the literature (e.g. Efimov 1990), three groups of characteristics are considered for the formation of chromatic scheme typology. They are related to color palette, color structuring (distribution of colors on the facades) and color dynamic (changes in the structure of palette).

In the search for operational criteria for the definition of typological schemes of the specific historical style, we consider the features related to the interconnection between form and color as fundamental. The following analysis of historical buildings is made: 1) comparison of back and detail coloration; 2) evaluation of the relationship between color and form limits (if they correspond to form contours or not); 3) proportion of colored areas in relation to the elements; 4) visual effects provided by the façade reading; 5) dynamics of coloring changes. According to the concept of chromatic typology defined in this study, dynamics refers to the range of chromatic variations allowed in a certain group of schemes without losing the essence of their style typology.



The investigation consisted of two stages. First, we studied the groups of buildings with architectural *styles* representative of three overlapped historical periods, which exemplify the most significant traces of architecture in the state of Rio Grande do Sul, Brazil, namely, colonial, eclectic and pre-modern styles. The relevant data were collected using complementary techniques such as, prospections (stratigraphic prospects) of buildings, survey of historical records and descriptions, analysis of images and study of projects with colored facades kept in historical archives (Naoumova and Dias Lay 2007, 2007a).

In the second stage, the chromatic typologies identified in this research were examined by the four groups of respondents, residents of the selected cities Pelotas, Piratini, Jaguarão and Bagé. The choice of these cities was driven by the fact that they have significant historical building heritages of the selected architectural styles. The study of chromatic schemes and the identification of characteristics that have contributed to their positive or negative evaluation were performed through the analysis of aesthetic preference (indication of *beauty*), arousal value - attractiveness (understood as *catching visual attention*), and suitability for a building (*adequacy* to a specific style).

To measure the aesthetic impact, a set of 60 chromatic schemes was created. This set has included the original authentic color schemes corresponding to the patterns used in historical periods and the non-historical schemes, corresponding the current painting of buildings in urban environment. The following characteristics of chromatic schemes were examined by respondents: 1) dominant *color component*, determined by four hues - blue, pink, yellow and gray; 2) schemes of *color structuring* including three types - with *light details*, with *dark details* and painting without distinction, named *one color*; and 3) *complexity of color composition*, also divided on three levels - *low, medium and high*. The obtained data were analyzed by statistical methods and tests: Gama association, Kendall W and Kruskal-Wallis (Naoumova 2009).

## RESULTS AND DISCUSSION

### Chromatic characteristics of the buildings of Luso-Brazilian, eclectic and pre-modernist language

The results of the first stage of the study supported the assumption that buildings with distinct stylistic architectural characteristics present identifiable and consistent color attributes (in terms of palette, structuring and dynamics). The methodological procedures adopted in the investigation allowed the elaboration of the typical chromatic schemes for each corresponding architectural style.

The chromatic typology of the *colonial style* (Luso-Brazilian language) was established by a palette with a narrow range: a) walls mainly in light tones (white, yellows, pinks), among them the ochre and faded pink could appear as more saturated; b) details in ochre, gray, less frequently in blue and faded pink; c) openings with dark colors in reddish brown, green and blue. The distribution of colors on the facades followed a combination of two or three hues that mark salient elements or a scheme with no highlight, with similar painting on background wall and details.

For the *eclectic style*, chromatic typologies were defined by palettes with a wide range of hues: a) walls with colors of medium lightness and medium saturated colors (blue, aqua green, pink, salmon, yellow, ochre); b) details in white colors, light yellow and beige tones. The structuring of these colors on the facades indicates the presence of at least three hues and harsh contrast between details in white and significantly darker walls. The results indicate that the coloring of buildings of the eclectic style presented much more chromatic diversity than buildings of colonial period.

The historical typology of the pre-modern style was characterized by the group of neutral shades (gray, ocher and beige). Facade decoration, concentrated on friezes and niches, was accentuated by texture and pigmented cements in ocher, reddish brown, pink and white. The research of color structuring on the facades showed soft combinations without strong contrast between elements and background wall, performed using small variations of the same shades.

### Aesthetic analysis: perception and evaluation of the historical typologies by residents

The historical chromatic typologies were analyzed in order to reveal how the original paintings of the old buildings are perceived aesthetically by the current inhabitants. In particular, we look for the answer to the question of whether these aesthetic evaluations vary with the different styles.

The respondents have assessed the suggested schemes of building paintings according to the three criteria: *beauty*, *suitability* and *attractiveness*. The indices of approval were obtained for each historical style using the five-step scale of the evaluation and also the ranking of each scheme according to the Kendall W test (Figure 1).

























n°	1	2	3	4	5	6	7	8
schemes								
	<b>C1</b>	<b>B1</b>	<b>M1</b>	<b>T1</b>	<b>R1</b>	<b>H1</b>	<b>K1</b>	<b>S1</b>
B	62,8%(13,1)	48%(11,6)	45,9%(11,5)	44,6%(11,1)	42,6%(10,9)	41,2%(10,4)	29,1%(8,6)	27,7%(9,3)
S	64,9%(12,5)	49,3%(10,8)	<b>67,6%(12,7)</b>	<b>69,6%(12,6)</b>	57,4%(11,2)	50%(10,8)	43,2%(9,7)	39,9%(9,7)
A	35,1%(9)	52,0%(11)	46,6%(12,2)	16,9%(6,7)	20,9%(7,5)	66,2%(12,6)	<b>75,7%(13,5)</b>	4,1%(3,7)
▲ Historical chromatic schemes of the colonial style (Luso-Brazilian language)								
schemes								
	<b>H2</b>	<b>B2</b>	<b>M2</b>	<b>L2</b>	<b>J2</b>	<b>C2</b>	<b>E2</b>	<b>O2</b>
B	76,4%(13,8)	73,0%(13,9)	71,6%(13,5)	70,3%(13,3)	64,9%(12,5)	50,7%(11,3)	50%(11,1)	27%(8,4)
S	85,8%(13,5)	89,9%(14,8)	79,1%(13,5)	80,4%(13)	65,5%(11,3)	68,9%(12,3)	56,8%(10,4)	29,1%(7,2)
A	49,3%(9,2)	63,5%(10,8)	39,2%(8,5)	<b>73,6%(12,5)</b>	40,5%(8,7)	56,1%(10,3)	34,5%(8)	43,9%(9)
▲ Historical chromatic schemes of the eclectic style								
schemes								
	<b>M3</b>	<b>N3</b>	<b>S3</b>	<b>J3</b>	<b>P3</b>	<b>R3</b>	<b>O3</b>	<b>E3</b>
B	54,7%(12,8)	47,3%(12,1)	42,6%(10,8)	39,5%(10,5)	37,2%(10,5)	36,5%(10,4)	35,8%(10,6)	16,2%(6,4)
S	70,3%(12,5)	61,5%(11,6)	56,8%(11,3)	45,3%(9,9)	55,4%(11,3)	53,4%(10,7)	55,4%(11,1)	23,6%(6,6)
A	27%(8,2)	27,7%(8,3)	5,4%(4,4)	38,5%(9,3)	7,4%(5,7)	8,8%(5,8)	23,6%(7,9)	55,4%(10,9)
▲ Historical chromatic schemes of the pre-modern style								

Figure 1: Evaluation of historical chromatic schemes of buildings according to the three criteria: *beauty* (B), *suitability* (S) and *attractiveness* (A). The values in each row show: 1) (left) frequency of positive evaluations and 2) (right) mean rank of scheme on complete style set (Kendall W test).

The brief discussion of the results for each of three criteria are exposed below.

**Beauty.** The highest favorable perception of the historical typologies occurred in the eclectic style, in which five schemes (H2, B2, M2, L2 and J2) were indicated among the most beautiful models of the entire set. In the colonial style, only one historical scheme (C1) was among the favorites of the set, and in the pre-modernist style - no historical scheme was chosen.

**Suitability.** As in the beauty assessment, the agreement between the current and historical adequacy was greater for the eclectic period. This indicates that the original paintings of this style are more similar to the chromatic patterns of suitability currently associated with such buildings. One of probable cause of this is the continuity of the painting traditions of these buildings. In the colonial group, relatively low indications of the historical schemes have shown that judgment on suitability degree has changed significantly over time. Also one can notice a significant dispersion in responses on the classification of the models. These results revealed that, on one hand, some typologies historically appropriate for colonial buildings were recognized as such by approximately two-thirds of the respondents. On the other hand, the current understanding of the suitability of the colonial chromatic schemes is broader, because other paintings with heavy colors, historically inadequate, were also pointed out with a high degree of suitability.

Since the small number of pre-modernist historical schemes was considered suitable to such buildings and also they were not indicated with high frequency, one can conclude that the majority of the respondents did not properly recognize these schemes. The low rankings also evidence the lack of agreement among the respondents on the evaluation of these typologies. The fact that the pre-modern historical schemes showed low indications of suitability, when compared with the other schemes of the complete set, indicated that the current chromatic pattern of the suitability of the painting of buildings of these style differs significantly from the original historical pattern.

**Attractiveness.** The original schemes of all styles were not considered attractive by most people, and the pre-modern historical typologies were evaluated as least attractive. Analysis concluded that people of today appreciate more eclectic historical schemes and enjoy less colonial and pre-modernist historical paintings. It's possible that this effect is caused by the lack of attractiveness due to the simplicity of the colonial building form and insufficient chromatic complexity of the pre-modern style.

**Chromatic attributes.** The results confirm that the evaluation of stylistic buildings is influenced by the chromatic attributes. Some attributes contribute in large-scale to a positive aesthetic evaluation of all buildings, and others, only to buildings of specific styles. A likely explanation is that the differences in evaluation occur due to perception not only of the formal aspect, but also the cognitive aspect, related to mental comparison of color features with iconic image of a specific style. Such findings corroborate the theoretical definitions of Kaplan and Kaplan (1983), who suggest that each artifact can be judged according to their suitability. It also confirms the assumptions of the Purcell (1984), about prototypicality of attributes (that is, the correspondence between a studied object and its typical pattern). The results suggest that color schemes are judged according to the existing patterns and in correspondence with the idea about the adequacy of their attributes to the building of a particular style or type. The work confirms that there are essential chromatic attributes of each style that qualify it better than others.

## CONCLUSION

The study showed the existence of strong influence of colors on aesthetic perception and evaluation of buildings of different styles. It was found that the increase of overall complexity of urban environment and intensity of color changes affect the perception and evaluation of historical built heritage in such a way that a lot more colors and chromatic combinations are currently perceived as suitable for historical buildings. Moreover, it was revealed that the current standard of color suitability is wider compared with the historical ones. Today, the tolerance of people to more saturated colors, strong contrast combinations and high complexity of color composition increased significantly. The fact that the majority of the historical schemes were assessed as unattractive proves this observation. It was shown that the methodology applied with the use of the concept of chromatic typology is an effective tool for the study of both historical schemes and people's preferences, and it can be used for the analysis of the evaluation of building colors, as well as serve as a basis for chromatic planning of the historical areas.

We may conclude that the search for differences and similarities in color evaluation of different building styles is important, because it helps to identify the variations of aesthetic responses in certain historical environment and, consequently, elucidate the possibility of favorable color changes. This information helps researchers to find the optimal level of flexibility of chromatic attributes, and also enables us to select the general attributes that can be successfully used in complex environments with multiple styles, and other more specific attributes that are appropriate only for specific style context. Moreover, the identification of differences between historical and current color patterns helps professionals to highlight the critical points of people's evaluation and, in this way, it becomes useful for color planning, allowing the development of the appropriate strategies to reduce color conflict in historical areas.

## REFERENCES

- Aguiar, J. 2005. *Cor e cidade histórica*. Porto: Edições FAUP.
- Efimov, A. 1990. [*The city polychromy*]. Moscow: Stroiizdat.
- Kaplan, S., and R. Kaplan. 1983. *Cognition and environment: Functioning in uncertain world*. Ann Arbor, MI: Ulrich's Bookstore.
- Naoumova, N. 2009. *Qualidade estética e policromia de centros históricos*. Universidade Federal do Rio Grande do Sul, Porto Alegre, doctoral thesis. <https://lume.ufrgs.br/handle/10183/16472>.
- Naoumova, N., and M. C. Dias Lay. 2007. Historical polychromy and chromatic identity of urban settings. In: *Proceedings of the 38th Annual Conference of the Environmental Design Research Association (EDRA)*, Sacramento, CA, vol. 1. Edmond, OK: EDRA, 90-95.
- . 2007a. Chromatic topology as a tool for analysis of urban historical polychromy. In: *Proceedings of the XIV Seminar on Urban Form*, Ouro Preto. Belo Horizonte: ISUF/UFNG.
- Norberg-Schulz, C. 1980. *Genius loci*. New York: Rizzoli.
- . 1984. *The concept of dwelling*. New York: Electra.
- Purcell, T. 1984. Aesthetics, measurement and control. *Architecture Australia* 73 (4): 29-38.
- Stamps III, A. E. 1989. Are environmental aesthetics worth studying? *The Journal of Architectural and Planning Research* 6 (4): 344-355.
- . 2000. *Psychology and the aesthetics of the built environment*. Boston: Kluwer Academic Publishers.

# Color territories: the colors of Boyaca, a palette for its identity

Carlos Mario Rodríguez\*, Elisa Teresa Violante

Universidad de Boyacá, Tunja, Colombia

\* carrodriguez@uniboyaca.edu.co

## ABSTRACT

The following paper shows the progress of the research project: “Color territories in Boyaca”, carried out by the Xisqua research group belonging to the University of Boyacá, Colombia. This formative research idea has brought together students from the Architecture and Graphic Design programs for a study of color in the urban landscape. This project analyses color as a means of expressing the identity of a region. As a cooperative project, it has been developed by the two aforementioned programs using their distinct perspectives which promotes a collaborative and interdisciplinary approach. The methodology consists of the analysis of color in the environment of each city or town taking into account their physical dimensions, such as urban landscape and housing, as well as their inhabitants’ perspectives. As a comparative study, it shows a chromatic map of the territory and a new way to understand the identity of a region.

**Keywords:** *urban color, landscape color, territorial identity, environment*

## INTRODUCTION

Boyaca is a department located in the central region of Colombia, this is a region considered to be culturally and naturally wealthy. Many of its towns are historical and natural landmarks as well as possessors of a series of local customs and traditions expressed through festivals, religious celebrations, handicrafts, artistic performances and particular gastronomy.

Providing these cultural traits, the recognition and value they deserve is a way to comprehend the identity of this region and, it is also one of the main objectives of the Xisqua research group. Under this perspective, the study of color in the environment has been considered a resource in order to characterize the towns’ identity and, in the long term, to establish a chromatic interpretation of the landscape as a portrait of the traditional culture of Boyaca’s people.

This research project followed a descriptive and comparative approach. Its main techniques are direct observation and collaborative work with the communities. Likewise, this proposal was structured as an interdisciplinary practice in formative research. For this reason, a work team of students from the Graphic Design and Architecture programs was created and as a result, the Gama

students' research group was established with the purpose of studying color in an urban environment in a holistic manner.

The methodology implemented is based upon the studies on chromatic analysis (Rodríguez 2014) that were developed inside the research group. The pilot exercise was made in the city of Tunja, which is also the capital city of Boyaca, and it allowed the identification of two different contexts of the study of environmental color: firstly, the context of physical color related to natural and artificial landscapes, and secondly, the imagined color context related to the popular consciousness that emerge from the perception of its inhabitants and the semiotic relationships established with color.

The current progress of this project includes the analysis and characterization of seven towns. The first comparative results are presented through the definition of different color palettes, resulting in the elaboration of a chromatic map of the department. Nevertheless, the process of approaching popular consciousness through color has revealed both positive and negative aspects concerning the current situation of each town. In that sense, the physical dimension of color is not the only fundamental factor which characterizes identity, because in that regard, it is also important to take into account all of the links and meanings established in the relationship between an individual and the territory.

## METHODOLOGY

This project is structured through the encounter of two disciplines: Architecture and Graphic Design, and in this context, to involve students from both programs by means of the promotion of collaborative and interdisciplinary work.

The two lead researchers of the project are Elisa Violante (architecture) and Carlos Mario Rodríguez (graphic design) who also act as mentors for the data collection process carried out by the students of the Gama research group, who had to pair up in order to conduct a task in each town.



Figure 1: Fieldwork performed by a group of students from the research group.

As for the data collection techniques, as well as the design of the instruments, they were developed by the lead researchers; however, once the students take part of the research group, they are trained and given the freedom to adapt the instrument to each specific case. This means that both teachers and students are responsible for the project and the results of the study are constituted as a co-authorship between the lead researcher and the student researcher.

In order to approach each town, certain variables that condition the environmental color have been taken into account (Boeri 2010). Some of those are related to the existence of random colors provided by the changes in light, weather and season. Similarly, permanent colors linked to the stable elements within the environmental images, such as monuments, streets and building facades. In this sense, the group's work has made it possible to characterize two contexts in order to understand the territory: the physical color and the imagined color (Rodríguez 2014)

Each town is analyzed by groups of two students who analyze both contexts, the physical and the imagined from which, the chromatic study is carried out. Thus, this research exercise constitutes a collaborative process of information gathering in which one of the students focuses on the context of physical color and the other one on the context of the imagined color, this is done with the purpose of both students complementing each other's process.

The analysis of physical color includes the environment's seasonal situation (weather and nature variations) and the spatial situation (building materials, facades' paintings, lighting). In this case, the objects of study are: the color of the constructed environment, architecture (building facade and streets), natural environment color (landscapes, flora and fauna) and the color of the cultural performances or popular expressions (handicrafts, festivals). A direct observation technique and instruments like sample recollection as well as photographic records especially based on Jean-Phillipe Lenclos' methodology (1999) as well as the colors pattern analysis developed by Universidad de Caldas (Gómez Alzate et al. 2006). Charts are designed in order to systematize the information gathered and the results are general and specific summary pallets of the chromatic values.

The imagined color analysis includes all the cultural aspects of the studied population, which entails historical, social and subjective factors from the citizens like gender, age, residence time as well as the experiences and memories related to the territory. In this context, the perceptions and social consciousness of each town's inhabitants are the objects of this study. Techniques like surveys and public participation workshops as well as instruments such as drawing workshops and group mapping were used. The methodological design was based on the study of the urban imaginaries theory proposed by Armando Silva (2006) and the methodology presented by Rodríguez (2013). The results of the study are chromatic readings that characterize a population from color linked to social aspects.

## **PRELIMINARY RESULTS AND CONCLUSIONS**

At this point, the study has made a chromatic reading of Tunja, Nobsa, Tibasosa and Ráquira, and other towns such as Moniquirá, Tenza and Monguú are being carried out at the moment.

The results obtained in each place have made it possible to perform a chromatic synthesis, expressed through color palettes developed under the Natural Color System. This enables the understanding of the different dimensions of color, and when they are seen from a broader perspective, they slowly define a color reading of the region.

The interdisciplinary nature of the research group allows these palettes to have different uses according to the interest and particular knowledge of the students. As an example, some design pieces have been developed such as tourist posters, didactic material and architectural proposals in order to revalue zones of historical interest and degraded urban environment.

In the same way, the synthesis based on the palettes allows the formulation of a "urban color plan" which constitutes a useful planning instrument for the municipal administrations in order to regulate the preservation of buildings and urban plans at historical centers.

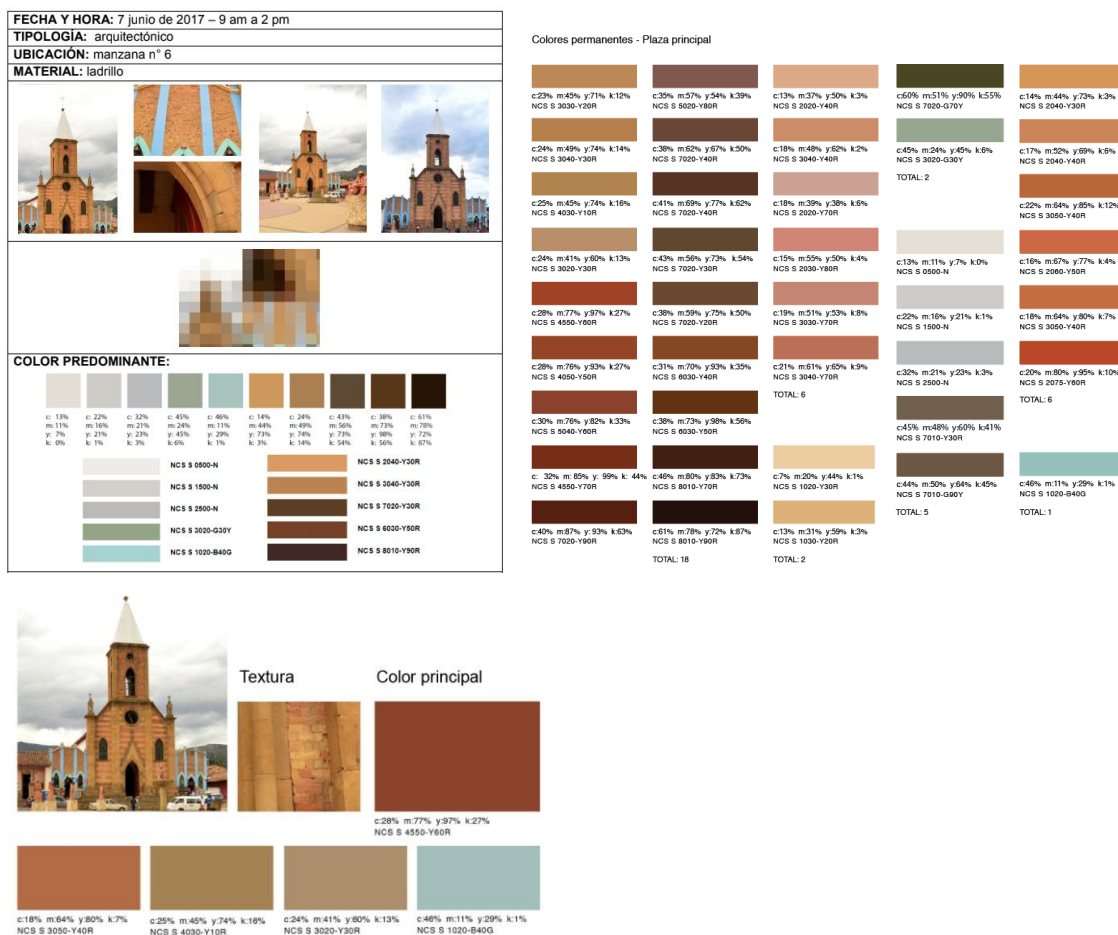

Figure 2: Process and result of the color palette construction from some elements of the constructed environment. Developed by student Elizabeth Zorro from the Gama students' research group.

On the other hand, the analysis of the perceptions and the imaginaries have generated a reflection around each population's dynamics and they allow the establishment of the relationship between the inhabitants and the environment. To quote some of them, in places such as Ráquira (Patiño and Rodríguez 2018), despite the results of the physical color analysis which show a multicolor palette, the inhabitants perceive the place as gray due to the pollution coming from the everyday production of the ceramic factories' ovens which are the economic axis of the town. In places like Tibasosa, the memories of the town were analyzed according to the information provided by elderly people and the narratives told on the murals which are painted on the majority of the houses in the town center. In Nobsa, a reading of the color was established by using the handicraft products and the production of wool fabrics.

Finally, the process continues with the integration of new students into the students' research group. In each town an experience is formed, and it validates or modifies the research procedures which are then replicated in new studies. According to Marc Augé (2000) identity is the element that fuses, gathers and joins the population in a place. Is well know that, globalization leads to homogenization of identity and the loss of the particular characteristics of towns, in this manner, the project has the purpose of strengthening local culture and their identity which are, metaphorically, expressed through the unique chromatic values found in each locality.





Figure 3: Process of the graphic synthesis of color imaginaries. Developed by the student Milena Vargas from the Gama students' research group.

## REFERENCES

- Augé, M. 2000. *Los "no lugares" espacios del anonimato – Una antropología de la sobremodernidad*. Barcelona: Gedisa.
- Boeri, C. 2010. A perceptual approach to the urban color reading. In: *Color and light in architecture*, P. Zennaro, ed. Verona: Knesesi, 459-463.
- Gómez Alzate, A., C. Jurado Grisales, and W. Castañeda Marulanda. 2006. *Patrones de color – Interpretación visual de los valores cromáticos regionales en Caldas*. Manizales, Colombia: Universidad de Caldas, Cuadernos de Investigación 24.
- Lenclos, J.-P., and D. Lenclos. 1999. *Couleurs du monde: géographie de la couleur*. Antony: Éditions du Moniteur. English translation by G. P. Bruhn, *Colors of the world: the geography of color*. New York: W. W. Norton & Company.
- Rodríguez, C. M. 2013. *Cromatología de la ciudad imaginada*. Tunja: Ediciones Universidad de Boyacá.
- . 2014. ¿De qué color son las ciudades? Metodologías de apreciación cromática urbana. *Designia 2* (2): 14-35.
- Silva, A. 2006. *Imaginarios urbanos: hacia la construcción de un urbanismo ciudadano. Metodología*. Bogotá, Colombia: Convenio Andrés Bello, Universidad Nacional de Colombia.
- Patiño, J. M. V., and C. M. Rodríguez. 2018. Territorios del color: análisis del imaginario del color de Ráquira. *Designia 5* (2): 102-119.

# Color, identity and space in digital games

Anamaria Rezende<sup>a\*</sup>, Nivia B. Ferreira<sup>b</sup>

<sup>a</sup> Universidade de Sao Paulo, Faculty of Architecture and Urbanism, Sao Paulo, Brazil

<sup>b</sup> Universidade Anhembi Morumbi, School of Exact Sciences, Architecture and Design, Sao Paulo, Brazil

\* anarezendeg7@gmail.com

## ABSTRACT

In game design, color has many functions and is widely used as a tool to facilitate the identification of objects, evoke emotions, create ambiance or even reduce emotional impact. According to its expression and language, it assists in the identification of the vocation as a casual game or a core game, has the ability to give a visual hierarchy to the elements explored as well as facilitate the perception of the passage of time and space. Some games explore color in order to generate the perception of new mechanics, that is, color is exploited as a resource for intuitive understanding by players, as it is used by designers as an Identifier to clarify the properties of an element in the game, being an item or an area, since color can communicate whether these elements are interactive or not and how they can (or should) be used.

This article aims to analyze and understand how color contributes to the generation of identity and meaning of space by the player in digital games that present more elaborate fictional worlds. Based on the questions “Does color confer identity and meaning to the game space?” and “how the player gives significance to the space?” we intend to analyze the roles of color in games, using the concepts of landscape, space and place according to geography, understand how these are represented in digital games and how the decisions in the aesthetic dimension of the game reverberates to the narrative, mechanical dimensions and technology considering the concept of *magic circle*.

The relationships between colors and fictional worlds and how they are part of the digital game associated with rules and narrative will be analyzed and discussed. This study seeks to identify repetitive practices, to serve as a reference to the designer supporting his creative process, as well as providing him and the player the meaning of space, and also generating a new stimulus to the motor and spatial intelligences immersing the players into a space unknown compared to their everyday life. The hypothesis outlined in this article is driven by concepts of information design and how colors contribute to the identity and significance of space by the player, using case studies as references. It is glimpsed that the inherent complexity of the field of game design is fertile ground for investigation and elucidation of events around the landscape and color as expression and information.

**Keywords:** *color in game design, identity, space, digital color*

# Color in residences for the elderly: ideas competition for scholars

Juan Serra-Lluch\*, Javier Cortina-Maruenda, Ana Torres-Barchino

Grupo de Investigación del Color en Arquitectura, Instituto de Restauración del Patrimonio,  
Universitat Politècnica de València, Spain

\* juanserra@ega.upv.es

## ABSTRACT

We explore the possibilities of color to improve the quality of living in existing residential buildings for the elderly. We show some of the interior design projects developed by scholars enrolled in the Master in Architecture in Valencia who participated in the “Gesmed ideas competition: Color in residential buildings for the elderly”. Every color project started from the analysis of the needs detected in current spaces like disorientation in big size rooms and a particularly concerning general lack of cosines. Together with these initial needs, the chromatic resources explored by other artists and architects in noteworthy buildings were analyzed to guide the final formal solution. The goal is to help elder people to feel like at home and maintain their memories by using simple interior design interventions.

**Keywords:** *color in architecture, interior design, elderly, Gesmed*

## INTRODUCTION

The disposition of color is a good starting point to reflect about the architectural possibilities for an interior design project. Course after course, scholars enrolled in the subject “Graphic and Chromatic Design” of the Master in Architecture, accept the challenge of updating an existing inner space by using simple architectural actions: redistribution of rooms, refurbishment, graphic design and color. The places to work in are existing buildings where users find problems or the owners consider that need a renewal. A company external to the university is involved in the activity and awards the best project in an architectural ideas competition. In previous editions, students worked in the offices of the international enterprise [Guzman Global](#), the rooms of the research center LabHuman, or the waiting rooms of [La Fe hospital](#).

In the course 2018-2019, scholars have been working in three residences for elderly people of public ownership, managed by the Gesmed company near the city of Valencia: Manises, Chiva and Velluters. In each residence there is an architectural intervention in a living room and in the spaces that give access to it, as well as a global graphic solution for the signs of the building. Every project

pays a special attention to the use of color, to favor the visual comfort of the residents, responding to the functional, compositional, aesthetic, cultural and any other aspects that concur in the design of the interior space. A video presentation of all the projects is available [online](#).

### **CURRENT STATE OF PUBLIC RESIDENCES FOR THE ELDERLY IN VALENCIA**

The residential centers for the elderly are an architectural typology that is becoming very relevant in the context of the accelerated aging of the European population. The growing demand for places in these centers as an alternative to housing, invites to reflect on the most appropriate architectural conditions to accommodate the elderly. These residences become elder people's own house and therefore they should become their home, promoting and facilitating an optimal welfare state. It is necessary, therefore, to improve the stay of the elderly from an optimally developed physical environment, where the resident is stimulated in a functional, perceptual and emotional way.

To develop the architectural project for each one of the three residences selected, scholars and professors visited the places and recorded all the information needed, not only about the forms and colors of the existing buildings, but also about the problems that users and staff perceive in day to day. In the case of Velluters, Chiva and Manises, the architectural spaces were characterized by having a chromatic scene that tended towards white and neutral or very clear colors (Figure 1). From a perceptual point of view, the spaces were cold and impersonal, thus being spaces of an institutional aesthetic. Some of the most common needs detected were difficulties related with glare, disorientation in big size rooms and a particularly concerning general lack of cosines. Definitely, users would like to feel like at home.



Figure 1: Current state of the residences in Manises (a) and Chiva (b).

### **CHROMATIC RESOURCES TAKEN FROM OTHER EXAMPLES**

Together with the information collected on site, every color project started from the cast of the chromatic resources assimilated in a previous work of analysis of existing noteworthy architectures. It is important to emphasize that color is an effective vehicle to achieve architectural intentions connected with the ideation. Depending on the main idea that drives the design, the different color

projects developed in this experience can roughly be categorized in three groups: (1) projects in which color relies on the function, (2) projects that seek for nature and vegetation, and (3) projects that opt to recover memories. Some chromatic possibilities like dynamism, kinetics in spaces, anamorphisms and other optical effects were left aside because of their disturbing effect for elder people; despite scholars studied some of these interesting resources in other contexts after some artists like Felice Varini, Olafur Eliasson, Carlos Cruz Díez or Boa Mistura.

## COLOR AND FUNCTION

Color may interfere in the functional organization of the architectural spaces, in the orientation of the users and their circulations, or in the characterization of the functional destiny, after the critical reading of some buildings by Norman Foster (Arnoldi 2007), Richard Rogers or Renzo Piano.

In the project “[Colourful Chessboard](#)” (Figure 2), the room of a wide corridor is divided in different zones intended for different activities and colors help in the description of these smaller areas. With a similar concept, in the project “[Feel at Home](#)”, the main idea is to create integrated areas, divided but keeping the unity. Other times, like in “[El día que mi abuelo se volvió color](#)”, the living spaces are drawn after the expression of the activity flows, by displaying different concentrations of holes in the ceiling. In this case, colors are subtle and display a neutral environment for living, after the understanding of specific architectures by RCR architects, Selgas Cano, or Peter Zumthor.

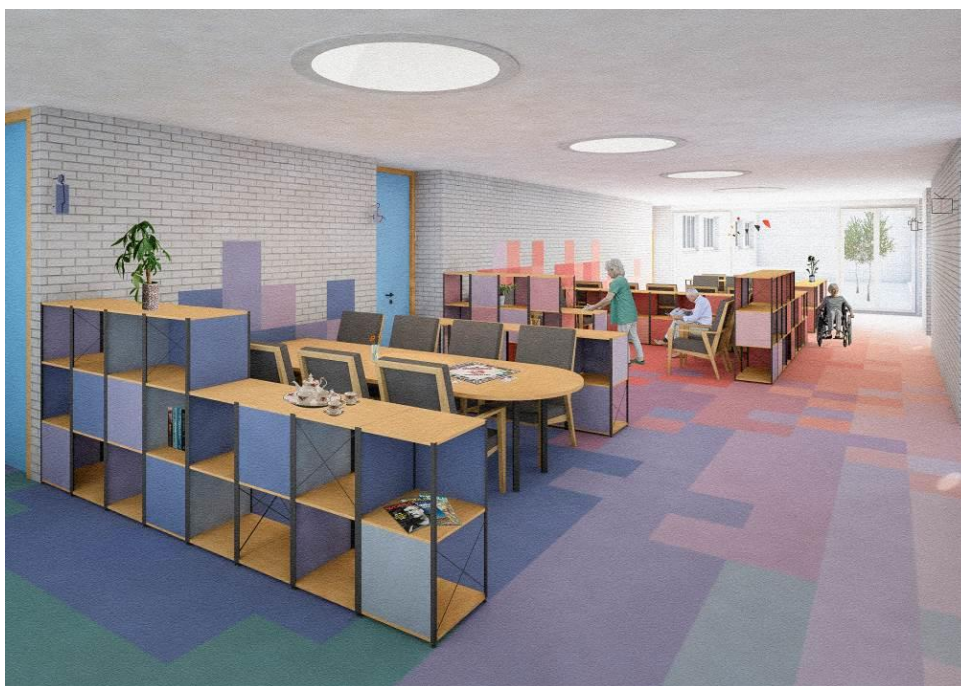

Figure 2: “Colourful Chessboard” by Mattia Tonini & Simon Hagen.

The project “[PATHofLIGHT](#)” (Figure 3) takes the color palette from the canvases of the famous Valencian painter Sorolla to reorganize the functional distribution of the different areas and help elder people in their way finding. A similar ideas was developed in the project “[Color Tube](#)”, but taking the illustrative language of the metro plans as a reference. This clear and direct visual language helps in the orientation. While the color of the symbol always relates to a specific use or activity, the background color points out on which floor of the building they are.



Figure 3: "PATHofLIGHT" by Claudia Galván Zuloaga, Iñaki Millán Omar & Rocío Gramage Micó.

### COLOR AND NATURE

Sometimes color and the general design tries to link inhabitants with nature displaying greenery or evoking the sense of a landscape, after the critical reading of projects with roots in the ecological utopians from the sixties and contemporary sustainable architecture (Serra-Lluch 2019).

The project "We all love nature. Don't we?" (Figure 4) is confident in the presence of vegetation to improve the quality of living in the residence. The main idea is to create the interior of the corridor in a way reminiscent of nature. Going out from the private rooms (the only private spaces in the residence) should be a metaphor of going out from houses for a walk to the forest and make elder inhabitants feel fresh, relaxed, and cozily.

The project "Circular Nature" works with the idea of an abstraction from nature. The colors are displayed on the glass walls in the form of silhouettes of the vegetation present in the garden behind it by using a self-adhesive foil on the windows. The silhouettes of the different types of plants or trees are completely made up of circles. Just like the very simple and easily understandable circular icons designed for the signals.

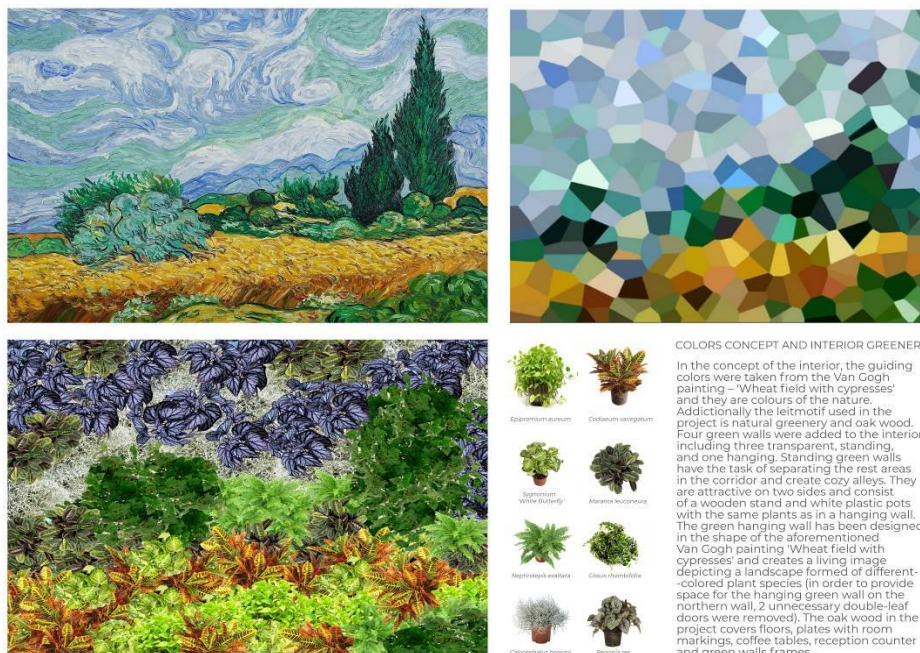

Figure 4: "We all love nature. Don't we?" by Olliwia Golenia & Anna Miroforidu.

## COLOR AND MEMORY

Some of the proposals tried to connect with the visual universe, the color codes and other cultural conventions that are usual for people in the range between 70 to 90 years old. Some different design strategies like the reuse of existing objects, vintage furniture or graphics from ancient advertisements, are some of the resources to help elder people to maintain their roots and not to lose their memory.

The project “[rightDIRECTION](#)” in Manises, develops a reinterpretation of the ceramic industry which was historically so important in this village. The colors and shapes for the signals, walls and furnishing are taken from the traditional Valencian tiles with two dominant hues: yellow and blue. “[The Tiled Cenefa](#)” also takes the ceramic tradition as a starting point. The variety of possibilities of a simple tile allows to play with a pattern in many ways and to find modern approaches and solutions for the traditional use of ceramic tiles. The color palette is taken from the ceramic tiles of the Modernist Central Market in Valencia (Hidalgo Delgado et al. 2010).

Memories are connected to specific objects which are familiar to us. Following this idea, the project “[Recuerdos, sueño, hogar...](#)” (Figure 5) uses photographs, texts, postcards etc. to reach a deeper connection between spaces and inhabitants. Similarly, the project “[...stand by them with colours](#)” (Figure 6) uses the iconography of ancient objects in different colors to help in the functional description of corridors which are too similar and banal.



Figure 5: “[Recuerdos, sueño, hogar...](#)” by María Montserrat Cadena Velasco & Florencia Stilman.

Residents are involved in the creation of a new color image for the interiors in the project “[Wood warm wool](#)”. With a very sensitive intervention, the proposal incorporates wood and wool to cover architectural elements as hand railings and columns. Wool handcraft is also used to create signage elements to replace the existing ones.

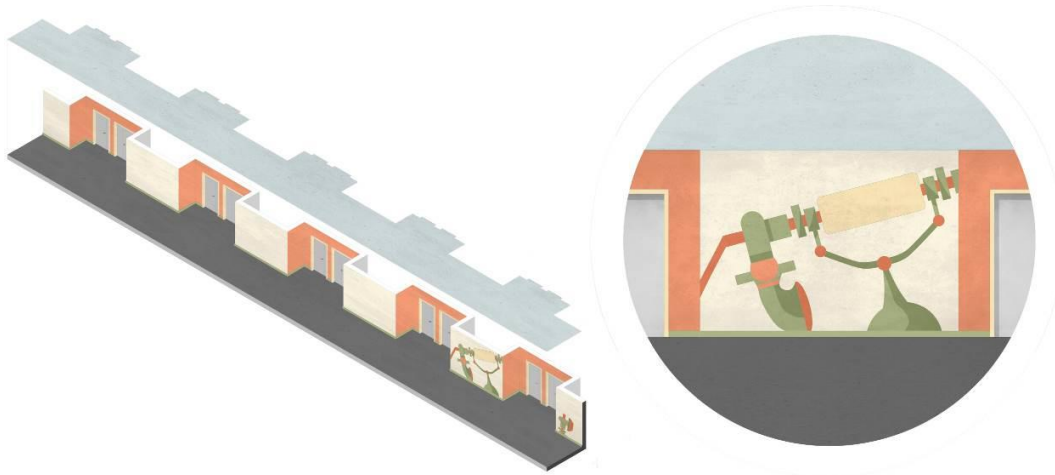

Figure 6: “...Stand by them with colours” by Jannis Sprenger, Manuel Rossi & Pablo Fillit.

## CONCLUSIONS

We have explored the possibilities of color to improve the quality of living in existing residential buildings for the elderly. We show some of the interior design projects developed by scholars enrolled in the Master in Architecture in Valencia who participated in the “Gesmed ideas competition: Color in residential buildings for the elderly”. Every color project started from the analysis of the needs detected in current spaces like disorientation in big size rooms and a particularly concerning general lack of cosines. Together with these initial needs, the chromatic resources explored by other artists and architects in noteworthy buildings were analyzed to guide the final formal solution.

We have pointed out three design strategies to improve the quality of living in existing residential buildings for the elderly: projects in which color relies on the function, projects that seek for nature and vegetation, and projects that opt to recover memories. All these projects demonstrate that it is possible to help elder people to feel like at home and maintain their memories by using simple interior design interventions.

## ACKNOWLEDGEMENTS

This paper is framed within the activities of the research project “Modifications of the Visual Comfort in Residential Centers to improve the Quality of Life for the Elderly” founded by the Ministerio de Economía y Competitividad de España.

## REFERENCES

- Arnoldi, P. 2007. *Colour is communication: Selected projects for Foster+Partners 1996, 2006*. Basel: Birkhäuser.
- Hidalgo Delgado, F., A. M. Torres-Barchino, J. Serra-Lluch, J. Llopis Verdú, and A. García Codoñer. 2010. The color of the tiles in the architecture of Valencia’s central market (Spain). In: *AIC 2010, “Color and Food: From the Farm to the Table”, Proceedings of the Interim Meeting of the International Color Association*, Mar del Plata, Argentina, 12-15 October 2010, J. L. Caivano and M. A. López, eds. Buenos Aires: Grupo Argentino del Color, 73-76.
- Serra-Lluch, J. 2019. *Color for architects*. New York: Princeton Architectural Press.



# Chromatic applications in interior spaces for the elderly in the P. Borja Geriatric Center of the Fontilles Foundation

Ana Torres-Barchino\*, Juan Serra-Lluch, Anna Delcampo-Carda

Grupo de Investigación del Color en Arquitectura. Instituto de Restauración del Patrimonio, Universitat Politècnica de València, Spain

\* atorresb@ega.upv.es

## ABSTRACT

The interior space in architecture is one of the most important concepts throughout the history of architecture. There are many characteristics that define the three-dimensional aspects of space in order to obtain a more habitable place. This communication is focused on a particular chromatic study, carried out in three interior spaces at the P. Borja Geriatric Center of the Fontilles Foundation (Alicante), where the appropriate chromatic modifications have been made to achieve improvements in their habitability. This Geriatric Center is specialized in the care of elderly people with varying degrees of dependency. This study is part of a research project carried out by the UPV Architecture Color Group, approved by the Ministry of Industry and Competitiveness of the Spanish Government (2016-2019). The aim of this research project is to establish parameters and chromatic modifications in built interior spaces of the public centers of the Valencian Community, where older people live.

**Keywords:** *color in architecture, interior design, elderly, space*

## INTRODUCTION

The facilities of the P. Borja Geriatric Center of the Fontilles Foundation (Alicante) present outstanding architectural features to be taken as a case study because it is a building located in a unique natural landscape, and it offers a climate especially suitable to accommodate people with certain dependency. It is a very different place from other centers that have been built in an urban area. This Foundation seeks to help the most vulnerable, it was created at the beginning of the 20th century, offering and carrying out various medical research projects. Thus, P. Borja Geriatric Center, that was constructed also at the beginning of the 20th century, is a benchmark of social compromise, where various studies on health and wellness are carried out. In this context, our study focuses, firstly, on an analysis of the original color of the most common rooms of this center; and, secondly, on the elaboration of new chromatic proposals that allow to improve the interiors spaces. The spaces

analyzed in this study are, today, the most used by residents in their daily lives: a multipurpose room where group activities are carried out, a corridor and its transit to other rooms, and a standard bedroom. All the chromatic modifications have been made in this pilot center.

### THE P. BORJA GERIATRIC CENTER: CASE STUDY

The P. Borja Geriatric Center, that is located on the town of Fontilles (Alicante), is part of the Sanatorium of Fontilles, an autonomous complex for the integral treatment of leprosy. Currently, the Center works according to the new model of Integral Person-Centered Care (AICP) since 1998, improving the well-being and quality of life of people and achieving the recertification of ISO 9001 / 2015 in 2017 ([fundacionfontilles.org](http://fundacionfontilles.org)). The building has been selected from about twenty of the public centers that have been analyzed in our color study of the Valencian Community because it is a historical building with particular characteristics that other centers in the region do not have; moreover, its architecture has undergone multiple modifications (Llopis 2017). Its presence, with a great volumetric impact, is characterized by the unique place where it is located, that is, its natural environment and landscape surrounding (Figure 1), as well as its wide interior spaces, that are not common compared with the rest of the residences analyzed.



Figure 1: Current state of the P. Borja Geriatric Center, in Fontilles, Alicante. Location and relationship with the natural environment.

The building was deeply modified in the second half of the 50s, with interventions such as the compartmentalization of rooms in smaller residential units to adapt the original project to modern hospital requirements.

Its natural environment of the Vall de Laguar (Alicante) allows to contemplate a landscape surrounded by large areas of Mediterranean woodland that offers a generous and quiet shading. At the same time, there are rest areas around the building that allow residents and family to walk. Therefore, the landscape and the climate generate a conducive environment with favorable conditions. The colors of the nature of the place: the blues of the sky, the greens of the vegetation and the ochres of the land, accentuate the feeling of well-being.

This set of conditions, such as its unique location and its great proportions, play an important role in the creative process of chromatic proposals that help to improve the perception of its spaces by offering a compositional design adapted to its architecture.

At the same time, in our Research Project on chromatic interventions in architecture for the elderly, color is considered as one of the elements that help to improve the visual comfort and mood of the residents, avoiding it being regarded merely as an element associated with the aesthetics of the building.

## THE PILOT CENTER: CASE STUDY

It should be noted that, before the chromatic intervention, the interior of the center was characterized, in its entirety, by the typical uniform yellow color in all its walls, and a dark green color in the metallic details such as handrails, carpentry and other elements of design. These colors promoted a hospital image that did not follow any previous study neither any habitability condition. Thus, it has been necessary to carry out an exhaustive analysis to elaborate a color chart determined by the organization of the space, the type of activity that is carried out in each area, as well as the need to update the spaces design to bring the resident closer to society.

A final objective of this study, is to establish chromatic modifications that help the perceptual improvement of residents (Torres-Barchino et al. 2017). To do this, as a previous phase to the chromatic intervention in real spaces, two types of analysis are established: firstly, to determine the visual state of the elderly through a deep literature review (Delcampo-Carda et al. 2019) as well as objective tests carried out in small groups (focus group) of elderly people aged between 70 and 90 years (VV.AA. MODIFICA 2019) (Figure 2).



Figure 2: Focus groups conducted in small groups of older people, to know their visual status and color preferences.

The conclusions drawn in this first theoretical-practical analysis determined the second phase of the analysis, that is, a survey consisting of a test based on images, of the best known rooms by the residents, visualized by virtual reality glasses in their original chromatic state and the same images modified in other color schemes previously selected by residents.

In these images, 4 different color schemes (mainly based on value and hue contrast modifications) of the three specific rooms were shown. Subsequently, the test aimed to collect the responses about the best perception of the spaces and the particular chromatic preference before carrying out the painting process in the center's facilities. For this, a questionnaire was prepared for each participant, consisting of 3 different parts, based on the evaluation of the three main real spaces existing in the Geriatric Center. Each of these spaces was presented individually. The participants needed to assess each space from 0 to 5 (Table 1), and provide a word that suggested that space, to know their most specific opinion (Figure 3).

0	1	2	3	4	5
Indifferent	Unsatisfactory	Average	Good	Very Good	Excellent

Table 1: Rating scale.



Figure 3: Test conducted to residents and staff of the P. Borja Geriatric Center. Visualization by virtual reality glasses of the images of the best known rooms by the resident: multipurpose room, corridor and bedroom.

It should be noted that spaces with color were better rated than white spaces, practically unanimously (Torres-Barchino et al. 2017). This result is coherent with previous scientific studies that analyze the disadvantages of spaces with a predominantly white use, since they promote monotony and lack of stimulation in the user (Dalke et al. 2006), prevent the orientation process as spaces lack of visual information (Delcampo-Carda et al. 2016), being able to cause anxiety and depression (Ainsworth 1989) and even visual fatigue due to the high levels of light reflectance (Mahnke and Mahnke 1987).

The chromatic proposals offered in our study for these spaces by using the new technologies of virtual reality, have given the possibility to visualize and select chromatic compositions before painting them. The combinations have been defined as a result of the previous study through geometric patterns that suggest harmony and dynamism, as well as the unquestionable participation of the older residents and the staff. Finally, the color compositions best valued by residents have been chosen for their intervention in each of the indicated rooms of the center. In addition, the natural lighting, orientation of the rooms or size, have been, among other spatial characteristics, the basic factors to define the set of chromatic interventions.

## RESULTS

As a result, various compositions were designed with geometric patterns and color variations between warm and cold shades (Figure 4). The difference of each one of the spaces studied, does not depend only on its dimensions, but on the lighting (natural light entrances and artificial light spots). Furthermore, the route that the resident makes during the day, has been a fundamental characteristic to determine any variation or color approach in the whole space. Depending on the activity to be developed in each room, we seek three different types of perceptions:

To perceive and generate an *attention space for transit time*: corridors.

To perceive a *balanced space for resting time*: bedroom.

To perceive a *dynamic space for action time*: activity or multipurpose room.



Figure 4: Before and after the chromatic intervention. Final result.

The result of this work has been carried out in the facilities of the P. Borja Geriatric Center for three years and culminates during this year 2019. The implementation of the color chart and its application in the indicated spaces, has demonstrated a new perception of them in the case study center, in which both residents and staff participated in the process in the different compositional designs intended for this place.

This research project, leads to the reflection of the study and application of color, as well as the idea of generating designs that help to improve the original built spaces whose modifications allow to improve the quality of life of older people with certain degrees of dependency.

Likewise, we believe that a common color chart cannot be established for all buildings of this type. The particular study for each type of center must be considered based on its own characteristics, as well as knowing the people who inhabit them.

## CONCLUSION

Currently, the residents of the center show a more positive mood after the color intervention in the inhabited spaces. The activity-multipurpose room as a group room and game room, has managed to improve the attitude of the resident. It is still too early to draw definitive conclusions. These conclusions should be determined throughout the rest of this year to assess the satisfaction results of resident users.

In short, our study is a pioneer in this type of experience in the Valencian Community, so a theoretical-graphic document is being prepared with the results of the tests based on the organization of color in residential spaces that will soon be revealed in a "White Paper", especially indicated to designers and architects.

## ACKNOWLEDGEMENTS

This paper is framed within the activities of the research project "Modifications of the Visual Comfort in Residential Centers to improve the Quality of Life for the Elderly" founded by the Ministerio de Economía y Competitividad de España.

## REFERENCES

- Ainsworth, R. A. 1989. *Color in the work environment*. Oregon State University, master thesis.
- Dalke, H., J. Little, E. Niemann, N. Camgoz, G. Steadman, S. Hill, and L. Stott. 2006. Colour and lighting in hospital design. *Optics & Laser Technology* 38 (4-6): 343-365.
- Delcampo-Carda, A., A. Torres-Barchino, and J. Serra-Lluch. 2016. El color como estrategia para mejorar la orientación y capacidad sensorial en la arquitectura destinada a personas mayores. In: *Dibujar, construir, soñar. Investigaciones en torno a la expresión gráfica aplicada a la edificación*, F. Felip Miralles, J. Gual Ortí, M. Cabeza González, and C. García García, eds. Castellón: Tirant Lo Blanch, 229-244.
- . 2019. Chromatic interior environments for the elderly: A literature review. *Color Research & Application* 44 (3): 381-395.
- Fundación Fontilles. Geriátrico Borja. Online: <https://fundacionfontilles.org/centro-geriatrico-borja>.
- Llopis, J. 2017. *Arquitectura y paisaje en el Sanatorio de Fontilles*. Col. Universitat Politècnica de València.
- Mahnke, F., and R. Mahnke. 1987. *Color and light in man-made environments*. New York: Van Nostrand Reinhold.
- Torres-Barchino, A., J. Serra-Lluch, J. Llopis Verdú, and A. Delcampo-Carda. 2017. Studies on color in residential architecture for the elderly. In: *AIC 2017, 13th Congress of the International Colour Association, "Being Color With Health", Proceedings*, Jeju, Korea, 16-20 October 2017. Seoul: Korean Society of Color Studies, OS03-04.
- VV.AA. MODIFICA. 2019. National Research Project *Modificaciones del confort visual en centros residenciales para la mejora de la calidad de vida de las personas mayores*. Valencia, Spain: AEI/FEDER, UE.

---

**Note:** This research was presented in poster format at the AIC 2019 Conference in Buenos Aires, and won one of the Robert W. G. Hunt Poster Awards (see Appendix, in this book).

# Color Vision and Psychophysics



# Experimental consideration on the effect of ipRGC for color reproduction on display device

Kota Akiba<sup>a</sup>, Midori Tanaka<sup>b</sup>, Takahiko Horiuchi<sup>c\*</sup>

<sup>a</sup> Graduate School of Science and Engineering, Chiba University, Chiba, Japan

<sup>b</sup> College of Liberal Arts and Sciences, Chiba University, Chiba, Japan

<sup>c</sup> Graduate School of Engineering, Chiba University, Chiba, Japan

\* horiuchi@faculty.chiba-u.jp

## ABSTRACT

This study aimed to experimentally confirm the impact of intrinsically photoreceptive retinal ganglion cells (ipRGC) on color reproduction of general display. Perceptual color matching of the color patch and the display were performed under 6000 K LED illumination in our experiment. The display used a high brightness liquid crystal display to control the influence of the rod. The color matching findings were significantly out of colorimetric color reproduction. We derived a correction formula of CIE XYZ obtained by correcting each value of CIE XYZ with the ipRGC absorption rate by regression. This formula derivation considers the fact that ipRGC may affect the color reproduction of the display. Based on the result, it is possible to demonstrate the color of the real object faithfully on a display device by using a color difference formula. This takes into consideration the influence of ipRGC different from CIE Delta E color difference.

**Keywords:** *ipRGC, color reproduction, color perception, display*

## INTRODUCTION

At the beginning of this century, cones and new photoreceptors separated from rods were discovered on the retina of mammals and were called intrinsically photosensitive retinal ganglion cells (ipRGCs) (Berson et al. 2002). IpRGC is a special ganglion cell containing the visual substance melanopsin. The spectral sensitivity function shown in Figure 1 was defined by the Commission Internationale de l'Eclairage (CIE 2018). In earlier research, it was believed that ipRGC had an impact on non-image-forming functions such as regulation of circadian rhythm and the pupil light reflex (Hattar et al. 2002). However, latest studies have increasingly revealed influences on visual perception such as brightness perception (Brown et al. 2012). However, as shown in Figure 1, the sensitivity functions of the LMS cones and the ipRGC overlap; all of the reports were based on experiments in a tightly controlled environment.



The color reproduction has been performed colorimetrically in conventional displays based on the perception quantity of the LMS cone at the photopic vision. In addition to the amount perceived by the LMS cone, it is also necessary to consider the effect of ipRGC on color reproduction of display devices. The consideration is appropriate in case of the ipRGCs influence on color perception as indicated in the recent reports. In this study, we aim to experimentally verify the effect of ipRGC on color reproduction of a display device.

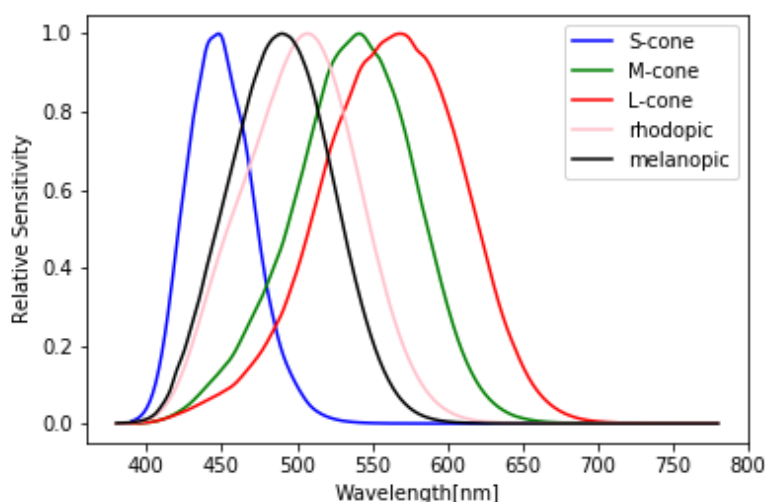

Figure 1: Relative sensitivities of cone, rhodopic and melanopic (ipRGC).

## EXPERIMENTS

In the experiment perceptual color matching was performed between color patches and color patches were reproduced on a display under 6000 K by 4500 lx LED illumination. The spectral distributions of both color stimuli are different. Therefore, matching results are expected without the smallest color difference, in case of the ipRGC impact on color perception. To control the influence of the rod we used a high-brightness liquid crystal display (Sharp PN-A601). As the real color patches, we used the X-Rite ColorChecker. Seven colors (red, blue, moderate red, blue sky, magenta, cyan, and white) with comparatively high reproducibility from 24 color patches were used as the color stimuli in this experiment. Many short wavelength components and many long wavelength components containing a color were selected in addition to confirm the effect at around 490 nm, which is the peak of the visibility of ipRGC. The reproduction accuracy was 1.5 on average with CIE 1976 Delta E color difference.

The experimental environment is demonstrated in Figure 2. A viewing distance was set on 150 cm. Thus the pixels on the display were not visible. On the other hand, when at this viewing distance, a patch of about 4 × 4 cm was placed side by side, the viewing angle was too small and matching was difficult. Therefore, the viewing distance to the patch was set to 60 cm and the stimuli were juxtaposed visually. The viewing angle of each stimulus was adjusted to 3.4 degrees. It was shielded from light by black paper except for the part displaying the color of the display. The color matching procedure was performed by independently adjusting the hue, saturation, and lightness. The colorimetric reproduction color with the smallest color difference was displayed for each stimulus as

the initial color. The experiment was performed after the training process. The adjusted color on the display device was measured using a spectroradiometer (Konica Minolta CS-2000) after the color matching experiment.

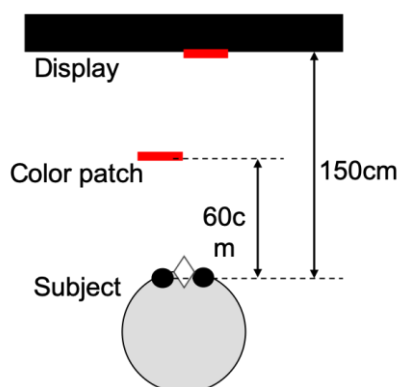

Figure 2: Experiment environment.

## RESULTS AND DISCUSSION

The CIE 1976 Delta E color difference of the reproduced color was calculated after the color matching and the color patch. The average statistical result of 10 subjects for each color stimulus was shown in Figure 3 together with the color difference of colorimetric color reproduction (initial color). The color difference average of the seven colors of colorimetric color reproduction was 1.5, whereas the color difference average after color matching was 9.5. The ratio of color difference was  $(\Delta L^* : \Delta a^* : \Delta b^*) = (0.74 : 0.14 : 0.12)$ , and the difference of  $L^*$  perception was the main influence. This outcome is consistent with the several recent reports that brightness perception is influenced by ipRGC. The effect of the difference in appearance mode was also examined. The hypothesis that it was strongly influenced by the difference in appearance mode was difficult to agree to, owing to high outcome of brightness stimulus. Focusing on the blue stimulus overlapping with the sensitivity of ipRGC, the color difference ratio was  $(\Delta L^* : \Delta a^* : \Delta b^*) = (0.50 : 0.11 : 0.39)$ , and the color difference of  $b^*$  was large. This result can indicate that ipRGC may also contribute to the color vision pathway.

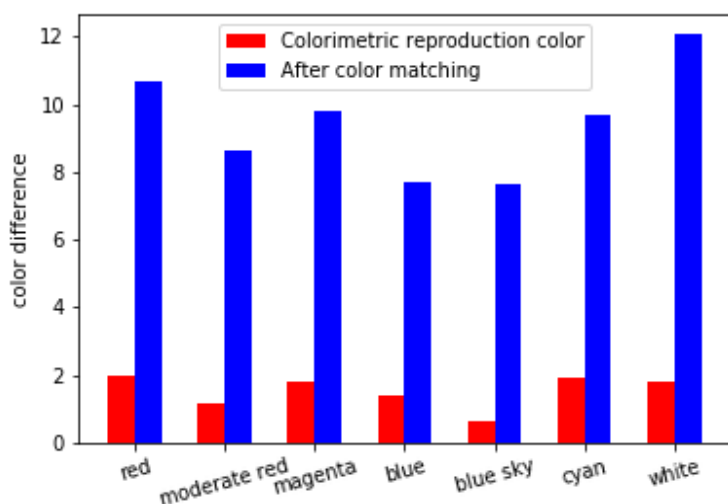

Figure 3: Average color difference of 10 subjects.

Previous opinions for a ganglion cell reported that ipRGC was acting after absorbing the tristimulus values. Therefore, the correction formula of CIE XYZ obtained by correcting each value of CIE XYZ with ipRGC absorption rate was derived by regression with the dependent variable as “CIE XYZ of a real color patch” and the independent variables as “ipRGC absorption rate” and “CIE XYZ” of the reproduced color on the display after color matching. The ipRGC absorption rate was determined based on the spectral sensitivity of ipRGC and the spectral distribution of the reproduced color on the display device. The modified XYZ values,  $X_{ipRGC}$ ,  $Y_{ipRGC}$  and  $Z_{ipRGC}$ , are derived as follows, including ipRGC effect:

$$X_{ipRGC} = 14.43 + 17.25 \times ipRGC + 1.45 \times X_m \quad (1)$$

$$Y_{ipRGC} = -2.02 + 72.42 \times ipRGC + 1.45 \times Y_m \quad (2)$$

$$Z_{ipRGC} = -60.77 + 433.38 \times ipRGC + 1.23 \times Z_m \quad (3)$$

where,  $X_m$ ,  $Y_m$  and  $Z_m$  represent the CIE XYZ values of the reproduced color on display device after the color matching including impact of ipRGC. The variable  $ipRGC$  means the ipRGC absorption rate of the reproduced color. By adopting the modified XYZ values Figure 4 presents the average color distinctions of 10 subjects. According to the description in the figure, The CIE Delta E color difference after color matching was 9.5 on average. After applying the modified XYZ values, it was improved to 3.4. Considering this result we can confirm that it is possible to display the color of the real object faithfully on display device by using a color difference formula that takes into account the influence of ipRGC different from CIE Delta E color difference.

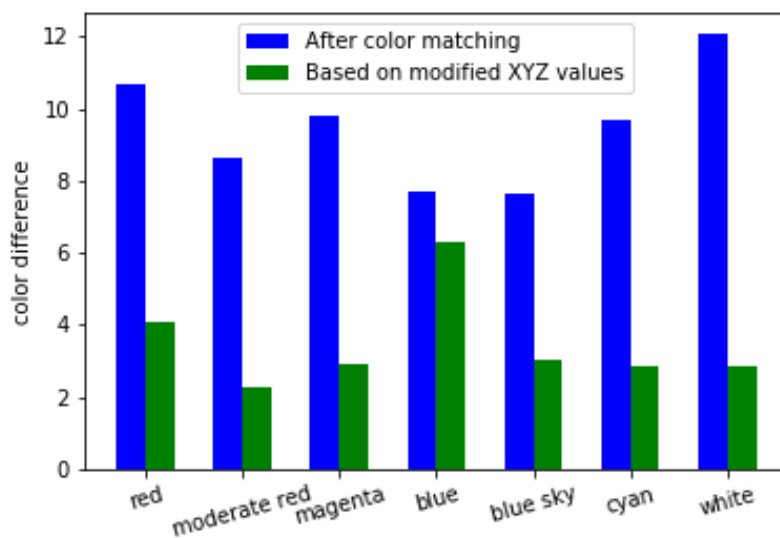

Figure 4: Average color difference of 10 subjects after applying the modified XYZ values.

## CONCLUSION

In this study, we experimentally verified the ipRGC effect on color reproduction of a general display device. The CIE 1976 color distinction was large, and the obtained matching results were different from colorimetric color reproduction. Thus, we assumed that the LMS signal was biased by ipRGC in ganglion cells. The study also provided derivation of the correction formula of CIE XYZ acquired by correcting each value of CIE XYZ with ipRGC absorption rate. The color difference was improved, and also suggested the necessity of ipRGC in the color perception of the display.

## ACKNOWLEDGEMENT

This work was supported by Grant-in-Aid of JSPS KAKENHI Grant Numbers 19K12038 and 15H05926.

## REFERENCES

- Berson, D. M., F. A. Dunn, and M. Takao. 2002. Phototransduction by retinal ganglion cells that set the circadian clock. *Science* 295: 1070-1073.
- Brown, T. M., S. Tsujimura, et al. 2012. Melanopsin-based brightness discrimination in mice and humans. *Current Biology* 22: 1134-1141.
- CIE (Commission Internationale de l'Éclairage). 2018. CIE system for metrology of optical radiation for ipRGC-influenced responses to light, CIE S 026/E:2018.
- Hattar, S., H. W. Liao, et al. 2002. Melanopsin-containing retinal ganglion cells: Architecture, projections, and intrinsic photosensitivity. *Science* 295: 1065-1070.

# Do color matching functions explain individual differences in color appearance?

Yasuki Yamauchi<sup>a\*</sup>, Tomonori Tashiro<sup>a</sup>, Yuki Kawashima<sup>b</sup>, Atsushi Konno<sup>a</sup>,  
Kunihiro Hatakeyama<sup>a</sup>, Takehiro Nagai<sup>c</sup>

<sup>a</sup> Yamagata University, Yonezawa, Japan

<sup>b</sup> NIST, Gaithersburg, USA

<sup>c</sup> Tokyo Institute of Technology, Yokohama, Japan

\* yamauchi@yz.yamagata-u.ac.jp

## ABSTRACT

It is well known that there exist individual differences in color appearance. In order to evaluate such individual differences, it is required to evaluate them quantitatively. Color matching functions (CMFs), which indicate the intensities of three primaries necessary to match reference light, is known that there are certain amounts of differences among observers. Moreover, it is reported that CMFs differ in shorter wavelength region depending on the method adopted to measure. We measured CMFs of an observer with two methods, maximum saturation method (MSM) and Maxwell's matching method (MMM). Moreover, we conducted metameric color matching experiments by using an LCD display to present the reference stimulus and a programmable light source was used to present the test stimulus. The residual color difference between the reference and the test stimulus, matched by each observer, was calculated using several CMFs (CIE1931, MSM and MMM). It turned out that for the less saturated reference color, the residual color differences were smaller with CMF obtained with MMM, while for more saturated colors, those with CMF obtained with MSM were smaller.

**Keywords:** color vision, color matching functions, metameric color matching, individual difference

## INTRODUCTION

It is well known that there exist individual differences in color appearance (e.g. Asano 2015). In order to evaluate such individual differences, it is required to evaluate them quantitatively. Color matching functions (CMFs), which indicate the intensities of three primaries necessary to match reference light, is known that there are certain amounts of differences among observers. There are two major ways for the measurement of CMFs: maximum saturation method (MSM) and Maxwell's matching method (MMM) (Wyszecki and Stiles 1967). There are several studies which reported that CMFs differ in shorter wavelength region depending on the method adopted to measure (e.g. Crawford 1965,

Yaguchi 1993). Pokorny et al. (2012) reported that the CMFs measured in saturated condition and less-saturated condition showed different trends between 410 and 510 nm.

In this research, we try to clarify which CMFs is an appropriate index to describe quantitatively individual differences in color appearance. For this aim, we need to measure CMFs of an observer with two methods and also collect metameric color matching data on the same observer.

## **EXPERIMENTS**

### **a) Color matching function measurement**

#### *Apparatus and stimulus*

We have built a compact apparatus to measure color matching functions as reported in Suzuki et al. (2011). In this apparatus, we used 20 different LEDs to measure the CMFs with three primaries of 471, 523 and 629 nm. We used this apparatus to measure CMFs with maximum saturation method.

For CMFs with Maxwell's matching method, we build an apparatus which can show the reference and the test stimulus with different light sources. The test stimulus was composed of the mixture of 20 LEDs, including the three primaries of 471, 523 and 629 nm. The reference stimulus was presented either with an LCD or with a programmable light source (OneLight). The subject could change the intensities of three LEDs: two LEDs used as a primary, and one LED for the test wavelength.

#### *Subjects and procedure*

Thirteen subjects participated in the experiment. In the experiments, the subjects first practiced how to change the color of the test stimulus to match the reference color. Then, the subjects conducted the matching for randomly presented reference colors. Each subject repeated three times for each reference color.

### **b) Metameric color matching experiment**

#### *Apparatus and stimulus*

For the experiment, the apparatus used for the measurement of CMFs with Maxwell's matching method were used to present the stimuli. In this experiment, two different conditions were adopted: less-saturated condition and saturated condition. For the less-saturated condition, the programmable light source was used to present the reference stimulus, and the subject changed the intensities of R, G, and B LEDs to match the reference color. For the saturated condition, the LEDs were used to present the reference colors, and the subject changed the color of the LCD by controlling a trackball attached to the PC.

For the saturated condition, 9 different reference colors were used. Each reference color was controlled so that they were included in the gamut of the LCD. For the less-saturated condition, 7 different reference colors were used. Chromaticities of the reference colors are shown in conjunction with those of the experimental results in the same graph.

#### *Subjects and procedure*

Two subjects participated in the saturated condition, while 3 subjects participated in the less-saturated condition.

Before starting each session, the subjects dark adapted for three minutes in an experimental booth. In the saturated condition, the subject changed the intensities of the LEDs (R,G, or B) until the appearance of the test stimulus matched to that of the reference stimulus. In the less-saturated condition, the subject changed the chromaticities of the LCD until the appearance of the test and the reference matched. There was no restriction of the time for the matching. Each subject repeated three times (less-saturated condition) and nine times (saturated condition) for each test color in 3 different days.

## RESULTS AND DISCUSSION

### a) Color matching function measurement

Figure 1 shows the color matching functions obtained in two different methods. Red, blue, and black lines denote CMFs by maximum saturation method, Maxwellian matching method, and those of CIE 1931 standard observer, respectively. Error bars denote one standard deviation.

As is clearly shown in the graph, the CMFs were different between those obtained in MSM and those in MMM. This is especially striking in the shorter wavelength range. This is the same trends with those reported in the preceding studies. On the other hand, the deviations for the longer wavelength range are very small regardless of the method adopted.

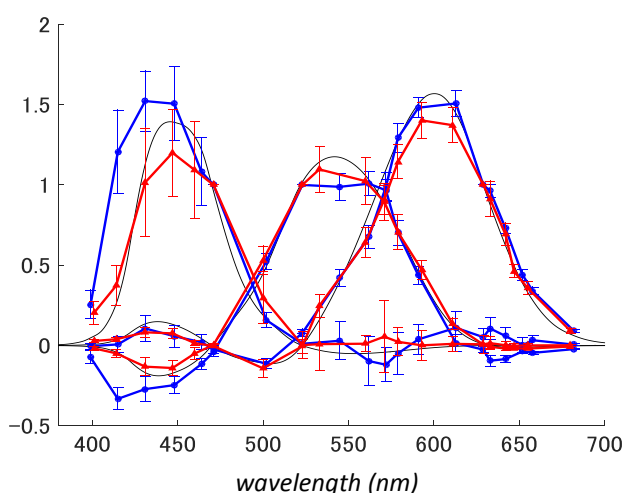

Figure 1: Average color matching functions among 13 observers. Red, blue, and black lines denote color matching functions by maximum saturation method, Maxwellian matching method, and those of CIE 1931 standard observer, respectively. Error bars denote one standard deviation.

### b) Metameric color matching experiment

Figure 2 shows the results of metameric color matching experiment. Panels (a) and (b) indicate for the saturated and less-saturated conditions, respectively. These panels are plotted with the chromaticities calculated with CIE1931 standard observer. Black symbols denote the chromaticities of the reference color, while red and blue dots indicate the chromaticities for each matching result.

As is shown in the figure, the chromaticities of the test stimulus were not identical for each matching in both cases.

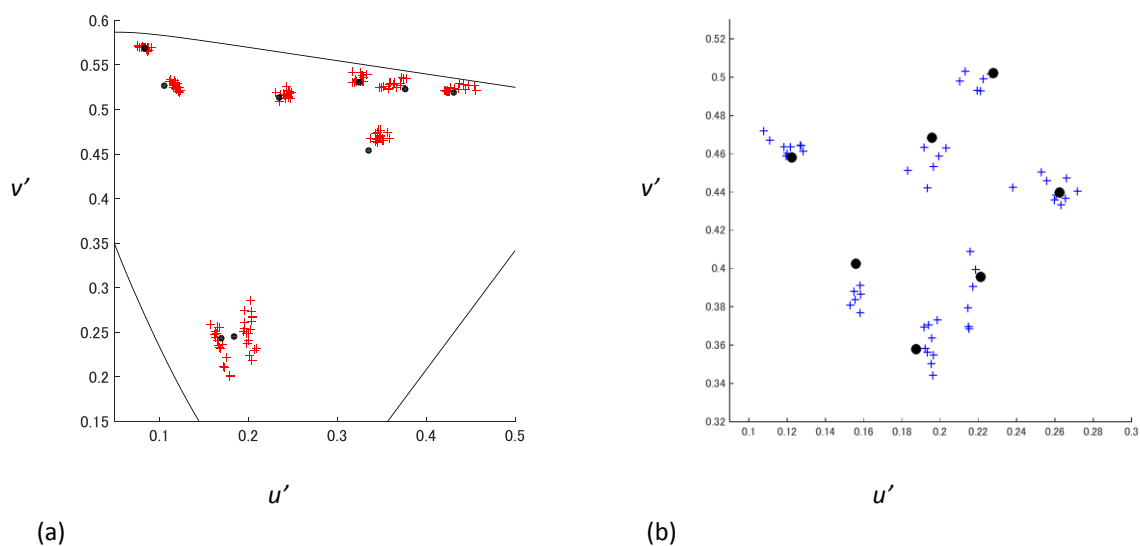

Figure 2: The results of metameric matching. Panel (a) and (b) indicates saturated and less-saturated condition, respectively. Black symbols denote the chromaticities of the reference color, while red and blue dots indicate the chromaticities for each matching result.

### Compensation using individual color matching functions

Finally, the two experimental results were dealt with together. Individual CMFs obtained in two methods were applied to the metameric matched spectral data, then calculated the tristimulus values for each setting. As was shown above, tristimulus values obtained using CIE1931 CMFs were not matched for the test and reference stimulus. If the compensation using individual CMFs is perfect, we would expect to obtain a complete fitted line with the slope of 1.

Figure 3 and 4 show the correlation between the chromaticities compensated for each observer obtained in saturated and less-saturated condition, respectively. As an example, in this paper, the B intensities calculated with blue CMFs. X axis denotes the B intensities of the reference stimulus, while Y axis denotes those of the test stimulus. Panel (a) and (b) indicates CMFs obtained with Maxwellian matching method and maximum saturation methods, respectively. Each point is the data obtained from all the matching made by all the subjects.

In the saturated condition shown in Figure 3, the correlation factor, which can be considered as a value of the slope of the best fit line, was higher for maximum saturation method than Maxwell matching method. The other primaries showed the similar trends, though the difference was smaller. The correlation factors are higher than those of CIE 1931 comparison.

The less-saturated condition, shown in Figure 4, showed a opposite trend. The correlation factor was higher for Maxwell matching method than for maximum saturation method. However, the difference was quite smaller.



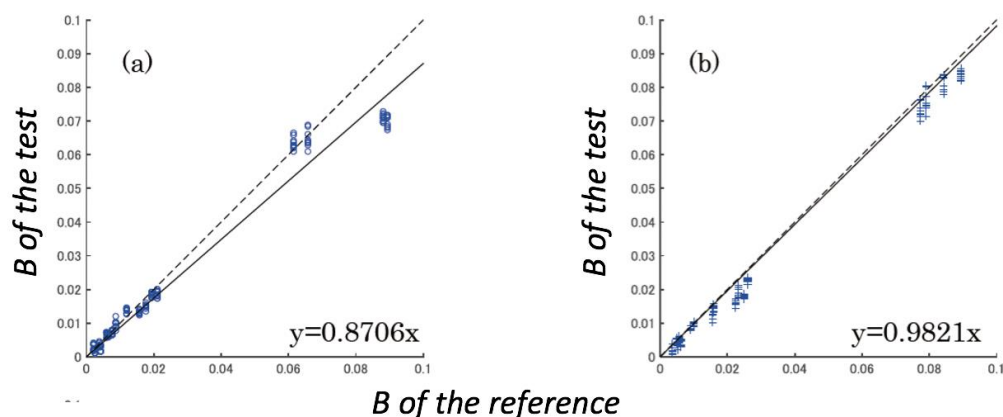

Figure 3: The correlation between the chromaticities compensated for each observer obtained in saturated condition. X axis denotes the B intensities calculated using individual CMFs of the reference stimulus, while Y axis denotes those of the test stimulus. Panel (a) and (b) indicates CMFs obtained with MMM and MSM methods, respectively. Solid line is the best fit line, and the equation is described in the panel.

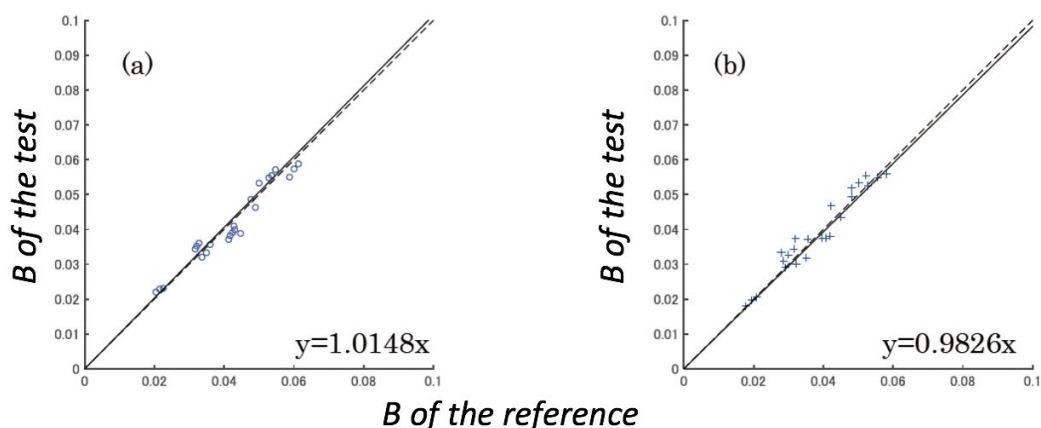

Figure 4: The correlation between the chromaticities compensated for each observer obtained in less-saturated condition. X axis denotes the B intensities calculated using individual CMFs of the reference stimulus, while Y axis denotes those of the test stimulus. Panel (a) and (b) indicates CMFs obtained with MMM and MSM methods, respectively. Solid line is the best fit line, and the equation is described in the panel.

## CONCLUSION

We verified that the individual color matching functions (CMFs) exist, and the CMFs are different values when measured in different ways (maximum saturation method and Maxwellian matching method). We also conducted metameric color matching experiment on the subjects whose CMFs were measured with two methods mentioned above. Residual color difference between the reference and the test stimulus, matched by each observer, was calculated using multiple CMFs (CIE1931, MSM and MMM). It turned out that for the less saturated reference color, the residual color differences were smaller with CMF obtained with MMM, while for more saturated colors, those with CMF obtained with MSM were smaller.

## ACKNOWLEDGEMENTS

Part of this research is supported by Topcon Technohouse.

## REFERENCES

- Asano Y., M. D. Fairchild, L. Blonde, and P. Morvan. 2015. Color matching experiment for highlighting interobserver variability. *Color Research and Application* 41: 530-539.
- Crawford, B. H. 1965. Color matching and adaptation. *Vision Research* 5: 71-78.
- Pokorny, J., V. C. Smith, and J. Xu. 2012. Quantal and non-quantal color matches: Failure of Grassmann's laws at short wavelengths. *Journal of the Optical Society of America A* 29: 324-336.
- Suzuki, T., M. Suzuki, Y. Yamauchi, and K. Okajima. 2011. Development of simple color bipartite apparatus using single light source with LEDs and measurement of individual color matching functions. In: *AIC 2011, "Interaction of Colour and Light", Proceedings of the Midterm Meeting of the International Color Association, Zurich, 7-10 June 2011*, V. M. Schindler and S. Cuber, eds. Zurich: pro/colore, 763-766.
- Wyszecki, G., and W. S. Stiles. 1967. *Color science: concepts and methods, quantitative data and formulae*. New York: John Wiley & Sons.
- Yaguchi H. 1993. Comparison between colour matching functions by the Maxwell method and those by the maximum saturation method obtained by a single observer. *Proceedings of CIE Symposium*, 93: 85-87.

# A framework and methodology for spectral color vision deficiency imaging

Raju Shrestha

OsloMet – Oslo Metropolitan University, Oslo, Norway  
raju.shrestha@oslomet.no

## ABSTRACT

People with color vision deficiency (CVD) face difficulties in everyday life and may get frustrated when they miss some of the important features in an image because of their inability to perceive differences between certain colors that can be distinguished by normal color vision people. This can affect access to education and choice in their career. In order to help millions of people affected by color blindness worldwide, a method known as daltonization is used, which tries to modify colors in a photographic image in order to increase the color contrast and bring back the missing features, thus improving the accessibility of the images in terms of retrieving information content for CVD people. A daltonization algorithm to work successfully, accurate conversion of a color image to a corresponding CVD image is vital. Many CVD simulation methods have been proposed, and most of them rely on color appearance theories and models that are imperfect. In addition, these methods are based on a generalization of CVD models and types. Moreover, color imaging has well-known limitations like environment dependency, metamerism problem, and it is limited to the visual spectrum. Since spectral imaging addresses these limitations effectively, spectral imaging-based simulation of CVD can produce individualized and more accurate results. In this paper, we present a framework for spectral image-based CVD imaging, which we call spectral CVD imaging, which can acquire an accurate personalized CVD image of a scene real-time under an uncontrolled illumination condition.

**Keywords:** *color vision deficiency (CVD), color blindness, simulation, spectral CVD imaging*

## 1. INTRODUCTION

Color blindness or color vision deficiency (CVD) is an anomaly or defect in a person's vision system that causes the person not to be able to enjoy the full-color world as do the normal vision people. Because of the anomaly, people with CVD cannot perceive the difference between certain colors and can miss some of the important features in an image. For example, some CVD people may not be able to distinguish between colors of a traffic light, while some others cannot differentiate between tomato,

lime, and orange. This can be extremely annoying and cannot only lead to frustration but also can affect access to education and choice in their career.

Depending upon type and number of defective cones among the three types of cone cells (L – long or red, M – medium or green, and S – short or blue) in our human vision system, CVD can be broadly categorized into three types: anomalous trichromat, dichromat, and monochromat. CVD with one cone whose absorption spectrum is shifted with respect to the spectrum of a normal viewer is called anomalous trichromats and depending on whether the L, M, or S cone is affected, the condition is called protanomaly (red-weak), deuteranomaly (green-weak), and tritanomaly (blue-weak) respectively. CVD, where one cone does not function because of the absence of or reduced sensitivity are called dichromats and based on whether L, M, or S cones are affected; they are respectively called protanopia (red-blind), deuteranopia (green-blind), and tritanopia (blue-blind). There are people with both red-green color deficiency (both protanope and deuteranope). Those with blue-yellow deficiency, which is rare, falls within the tritan case. People with two or three non-functioning cones are called monochromats, and they are completely colorblind, i.e. they cannot see color at all. There are 7-10% of males who have some form of red-green color deficiency, 2.4% males and 0.03% females have some form of dichromacy, and 6.3% of males and 0.37% of females have some form of anomalous trichromacy (Wong 2011, color-blindness.com 2019). Different techniques are used to diagnose CVD such as Ishihara tests, color arrangement tests such as Fransword D-15 and D-100, anomaloscopes, and pseudo-isochromatic plates (Birch 1982). Altogether, there are millions of people worldwide affected by CVD, among them about 8% are men and 0.05% are women (colorblindawareness.org 2019). A study with multi-ethnic children found that the prevalence of CVD in preschool boys varies by ethnicity, with the highest prevalence in non-Hispanic white and lowest in black children (Xie et al. 2014).

Daltonization is a process which attempts to recolor (modifying the color of) a photographic image intended for color blinded people to increase the color contrast so as to bring back the missing features. Daltonization aims for improving the accessibility of the images in terms of retrieving information content for CVD people. Several daltonization methods and techniques have been proposed (Anagnostopoulos et al. 2007, Kim et al. 2012, Kotera 2012, Milic et al. 2015, Simon-Liedtke and Farup 2015). Almost all these daltonization methods use simulated CVD images. Since CVD image simulation is an important step before applying daltonization that determines the effectiveness of the daltonized image, this is our main focus in this work.

Many methods have been proposed for simulating CVD images. As most of these methods are based on CVD models, which rely on color appearance theories and models that are imperfect, these methods are not accurate. Moreover, these CVD models are based on trichromatic color imaging, which has several limitations such as environment dependency, suffers from metamerism, and limited to the visual spectrum. Therefore, the generated CVD images are far from perfect. Moreover, as most of the color vision deficiency models are generic models, they may not reflect the perceptual capabilities of an individual with a specific color vision deficiency.

Since spectral imaging mitigates the limitations of the trichromatic color imaging, and with the availability of fast, simple, and inexpensive multispectral imaging technologies, an accurate simulated color vision deficiency image can be generated for a given type of color vision deficiency using a spectral image (Shrestha 2016). As an extension to this work, this paper presents a framework for a real-time personalized CVD imaging under an uncontrolled environment (illumination condition). We have named this imaging technique as spectral color vision deficiency imaging.

After this introduction, section 2 describes various related works on CVD image simulation. The proposed framework for a spectral CVD imaging is presented next in section 3. Section 4 describes experiments, and present and discuss experimental results. Finally, section 5 concludes the article.

## **2. CVD IMAGE SIMULATION**

Among many CVD simulation methods proposed in the literature, most of the state-of-the-art methods are model-based that are derived from the observations from unilateral dichromats (people with dichromacy in only one eye, while the other eye has normal color vision). These observations found that both the normal and anomalous eyes perceive achromatic colors similarly (Graham and Hsia 1959, Judd 1945). An early technique by Meyer and Greenberg (Meyer and Greenberg 1988) mapped achromatic colors in approximate wavelengths of 475 nm and 575 nm for protanopia and deuteranopia, and 485 nm and 660 nm for tritanopia in XYZ color space and drew confusion lines representing directions along which there is no color variation according to dichromats color perception. The simulated deficient color is then defined by projecting the colors through the confusion lines on the reduced gamut. Brettel, Viénot, and Mollon (1997) obtained dichromatic colors by projecting the original color on the semi-planes in the LMS color space by constraining the direction of confusion lines to be parallel to the direction of the color spaces axes L, M, or S, depending on whether the dichromacy type is protanopia, deuteranopia, or tritanopia respectively. These techniques produce reasonably good results for dichromacy; however, they are not usable for anomalous trichromacy. Jim (2019) has provided a similar simulation model based on sRGB-LMS conversions.

Yang et al. (2008) proposed a simulation technique for anomalous trichromacy, based on the conversion of colors from RGB color space corresponding to a typical CRT monitor to anomalous LMS, and then converting back from LMS to RGB space. Machado (2010) found that the simulated images from this technique contain colors that are not the ones perceived by individuals with color vision deficiency. As a solution, he proposed a physiologically-based model based on the two-stage opponent color model of human color vision, which he claimed to perform better in terms of preserving achromatic colors and simulating both anomalous trichromacy and dichromacy (Ingling and Tsou 1977).

All the CVD models described are based on general models hence may not reflect the perceptual capabilities of an individual with CVD. Flatla and Gutwin (2012) proposed an empirical model-based approach for a more accurate color representation of what a particular person with CVD actually sees. A physiologically-based CVD simulation model has been proposed which claimed to consistently handle normal color vision, anomalous trichromacy, and dichromacy in a unified way (Machado, Oliveira, and Fernandes 2009). Both these models are still based on color imaging model, they suffer from all the limitations of color imaging.

To address the limitations of color imaging-based CVD image simulation, spectral imaging-based CVD image simulation method has been proposed (Shrestha 2016). This work has been extended further hereby incorporating real-time CVD image acquisition capability.

### 3. PROPOSED FRAMEWORK AND METHODOLOGY FOR SPECTRAL CVD IMAGING

Shrestha and Hardeberg (2014) proposed a novel a concept and methodology for spectral imaging, named as spectrogenic imaging, which can acquire a spectral image of a scene under an arbitrary illumination condition. A spectrogenic imaging system is built with a 6-band camera system that acquires two images of a scene, a normal RGB and a filtered RGB. The illuminant under which an image is captured is estimated using a chromagenic based algorithm (Finlayson, Hordley, and Morovic 2005; Shrestha and Hardeberg 2012), and the system is calibrated automatically using the estimated illuminant. A spectral reflectance image of the scene is then estimated using an appropriate spectral estimation method.

The proposed spectral CVD imaging use this spectrogenic imaging system in order to generate an accurate simulated CVD image of the scene under the given illumination condition for an individual CVD person having individualized cone sensitivities using the spectral reflectance image (Shrestha 2016). **¡Error! No se encuentra el origen de la referencia.** illustrates a complete framework and workflow for the proposed spectral CVD imaging.

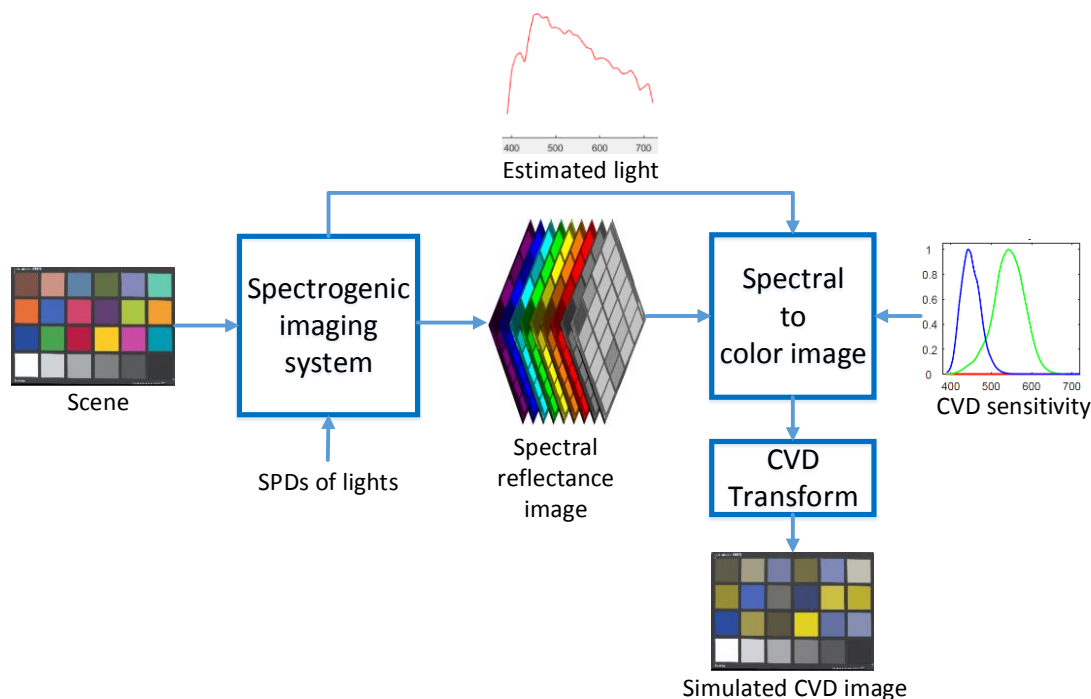

Figure 1: Schematic diagram of the proposed framework for spectral CVD imaging. The diagram shows SPD of D65 illumination and LMS sensitivities (Stockman and Sharpe 1999) for a protanope with a missing S-cone, as an example.

The spectral image-based simulated CVD images from Shrestha (2016) simply generates a simulated color image for a given CVD type using a standard color and spectral imaging model equations. This results in greenish, pinkish, and yellowish images in cases of protanope, deutanope, and tritanope respectively, which are not correct. Protanomaly and deuteranomaly images can also be refined further. This is done by adding a CVD transformation step in the CVD imaging framework. In this step, the color image generated from the spectral image is transformed into a simulated CVD image, where each channel of the CVD image is obtained as a linear combination of the three channels. Weights for the linear combination can be calculated by using certain constraints from the fact that some colors perceived in a CVD type remain the same as the colors perceived in normal color vision.

Let  $\mathbf{C}i = [c_{i1}, c_{im}, c_{is}]^T$ , where  $i = \{1, 2, 3\}$  denote the LMS color values of the three matching colors generated for a CVD in a vector notation and  $\mathbf{C}i^n = [c_{i1}^n, c_{im}^n, c_{is}^n]$  the corresponding color values for the normal color vision, the CVD transformation can be modeled by the following matrix equation.

$$\begin{bmatrix} c_{11}^n & c_{21}^n & c_{31}^n \\ c_{1m}^n & c_{2m}^n & c_{3m}^n \\ c_{1s}^n & c_{2s}^n & c_{3s}^n \end{bmatrix} = \begin{bmatrix} w_{11} & w_{1m} & w_{1s} \\ w_{m1} & w_{mm} & w_{ms} \\ w_{s1} & w_{sm} & w_{ss} \end{bmatrix} \begin{bmatrix} c_{11} & c_{21} & c_{31} \\ c_{1m} & c_{2m} & c_{3m} \\ c_{1s} & c_{2s} & c_{3s} \end{bmatrix} \quad (1)$$

Denoting the left matrix in this equation as  $\mathbf{C}^n$ , the weights matrix in the middle as  $\mathbf{W}$ , and the rightmost matrix as  $\mathbf{C}$ , the weights can be calculated using the equation,  $\mathbf{W} = \mathbf{C}^n \mathbf{C}^{-1}$ . We use white, green and blue as the matching color constraints for protanomaly, and white, red, and blue for deuteranomaly. In case of the dichromats, one channel output results in zeros as they have one cone missing. The missing channel output is calculated as a linear combination of the other two channels. Therefore, we use just two matching colors constraints in Equation 1. For protanope and deuteranope, white and blue, and for tritanope, white and red are used as the matching color constraints (Kulesza 2018). The third color  $\mathbf{C}3$  is set to  $[1, 0, 0]^T$  for protanope,  $[0, 1, 0]^T$  for deuteranope, and  $[0, 0, 1]^T$  for tritanope; and  $\mathbf{C}3^n$  is set to  $[0, 0, 0]^T$  in all the three cases.

In order to display a simulated CVD image on a screen, the image is white balanced, then converted from the LMS space to standard XYZ color space using the Hunter-Ponter-Estevéz transformation (Fairchild 2013), and then this image is finally converted to sRGB color space.

Since the spectrogenic imaging can be realized using different types of camera design and setup, such as using a stereo camera (Shrestha and Hardeberg 2012a) or using a custom spectral filter array (Shrestha and Hardeberg 2013), a spectral CVD imaging system can be realized easily using off-the-shelf cameras and by feeding an individualized or generic CVD cone sensitivities (standard ones for the people with normal color vision); and used in real practice.

#### 4. EXPERIMENTS, RESULTS, AND DISCUSSION

A prototype 6-band stereo-camera based spectral imaging system built with a Fujifilm FinePix REAL 3D W1 stereo camera and Omega XF1078 filter in front of one of the camera lenses from Shrestha and Hardeberg (2014) is used. A hyperspectral image of bear and fruit gray images acquired under the blue light from Brainard (2004) is used for the simulated output spectral image from the spectrogenic imaging system under a standard CIE D65 illumination. This test image is chosen because it contains several different types of objects including a Macbeth ColorChecker (MCC), bear, fruits, and books. The resulting spectral image is then used to simulate the five different CVD images, protanomaly, deuteranomaly, protanope, deuteranope, and tritanope as discussed in Shrestha (2016), using the proposed spectral CVD imaging framework as described above. As tritanomaly is rare, it is skipped here. The white, red, green, and blue color patches in the MCC are used to calculate weights in the CVD transformation (Equation 1) step to generated simulated CVD images. Figure 2 shows the five simulated CVD images along with the normal vision color image resulted from the spectral CVD imaging system.

From the resulting simulated CVD images, we can see how people with different CVD face difficulty distinguishing some colors. It is hard to verify the accuracy of the simulated CVD images without psychophysical experiments with a number of people having different types of CVDs. However, we find that the resulting simulated images are similar to the results from the most widely used simulator

Coblis-Color Blindness Simulator (color-blindness.com 2019). It is to be noted here that, the red, green, and blue colors used in the CVD transformation from the Macbeth ColorChecker are not pure primary colors. By using colors closer to pure primary colors, further improved results can be anticipated.

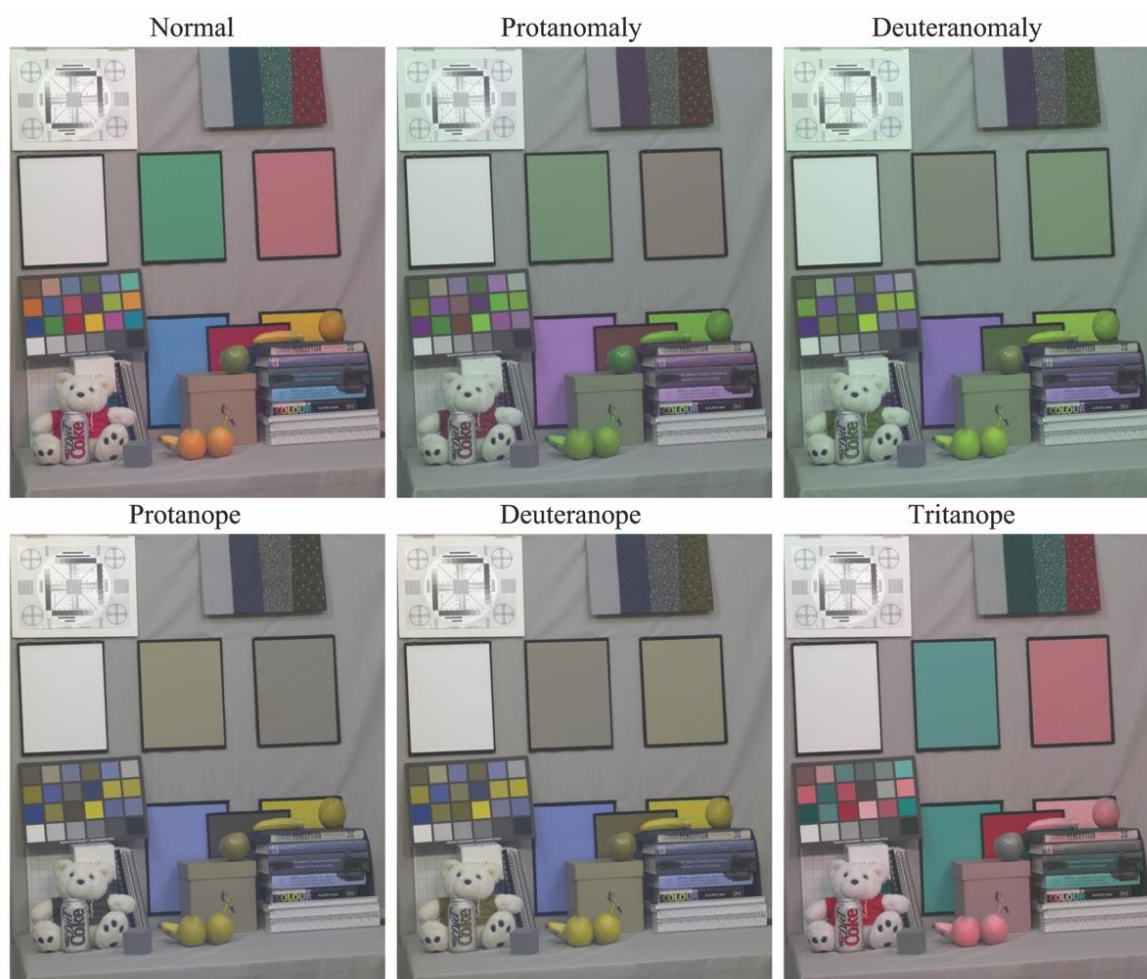

Figure 2: Simulated CVD images of the Bear and Fruit Gray image (Brainard 2004) in sRGB color space, generated from the spectral CVD imaging.

The main advantage of the proposed spectral CVD imaging is that a system based on the framework can acquire and generate a CVD image for an individual with a personalized CVD type, under an uncontrolled illumination condition in real-time by pre-calibrating and characterizing the system with custom cone sensitivities. Since the simulation is based on spectral imaging, we can anticipate more accurate simulation compared to a classic color imaging-based simulation. Also, having a spectral image, a simulated CVD image can be obtained under any given illumination. Moreover, the system can be incorporated with an in-built daltonization algorithm adapted to the personalized CVD type so that it can produce an enhanced image to minimize feature loss due to the CVD problem.

A limitation of the system is that the accuracy of estimation of illumination under acquisition depends on the richness of the dataset of spectral power distribution of light sources, which has the one close to the test illumination. Moreover, we assume that an individualized cone sensitivity is available to use it as a parameter in the system. However, in case of the unavailability of such data, the system can still be used with a standard cone sensitivity data for a specific type of CVD.



## 5. CONCLUSION

A spectral color vision deficiency imaging system based on the proposed framework and methodology can be used to acquire a simulated CVD image under an arbitrary illumination condition in real-time. Such a system can be built using off-the-shelf camera systems. The system can be customized or individualized for a person with a specific type of CVD by using his/her individual cone sensitivities, or by using cone sensitivities of a standard CVD type close to his/her. The system can be further extended with an in-built daltonization method for that particular CVD type to build a full-fledged camera system which can produce a daltonized image that brings back the missing features because of the CVD.

## REFERENCES

- Anagnostopoulos, C. N., G. Tsekouras, I. Anagnostopoulos, and C. Kalloniatis. 2007. Intelligent modification for the daltonization process of digitized paintings. In: The 5th International Conference on Computer Vision Systems.
- Birch, J. 1982. Diagnosis of defective colour vision using the Nagel anomaloscope. *Documenta Ophthalmologica. Proceedings Series* 33: 231-235.
- Brainard, D. H. 2004. Hyperspectral Image data. <http://color.psych.upenn.edu//hyperspectral>.
- Brettel, H., F. Viénot, and J. D. Mollon. 1997. Computerized simulation of color appearance for dichromats. *Journal of the Optical Society of America A* 14 (10): 2647-2655.
- color-blindness.com. 2019. Color blindness - Learn all about it. <https://www.color-blindness.com>.
- colorblindawareness.org. 2019. Colour blind awareness. <http://www.colourblindawareness.org>.
- Fairchild, M. D. 2013. *Color appearance models*, 3rd ed. New York: John Wiley & Sons.
- Finlayson, G. D., S. D. Hordley, and P. Morovic. 2005. Chromagenic colour constancy. In: *AIC Colour 05, Proceedings of the 10th Congress of the International Colour Association*, Granada, Spain, 8-13 May 2005, 2 vols., J. L. Nieves and J. Hernández Andrés, eds. Granada: Comité Español del Color, 547-550.
- Flatla, D. R., and C. Gutwin. 2012. So that's what you see: Building understanding with personalized simulations of colour vision deficiency. In: *Proceedings of the 14th International ACM SIGACCESS Conference on Computers and Accessibility*, 2012.
- Graham, C. H., and Y. Hsia. 1959. Studies of color blindness: a unilaterally dichromatic subject. *Proceedings of the National Academy of Sciences, USA* 45 (1): 96-99.
- Ingling, C. R., and B. H.-P. Tsou. 1977. Orthogonal combination of the three visual channels. *Vision Research* 17 (9): 1075-1082. <http://www.sciencedirect.com/science/article/pii/004269897790013X>.
- Jim. 2019. Color blindness simulation research. <https://ixora.io/projects/colorblindness/color-blindness-simulation-research>.
- Judd, D. B. 1945. Standard response functions for protanopic and deuteranopic vision. *Journal of the Optical Society of America* 35 (3): 199-221. <http://www.osapublishing.org/abstract.cfm?URI=josa-35-3-199>.
- Kim, H. J., J.-Y. Jeong, Y.-J. Yoon, Y.-H. Kim, and S.-J. Ko. 2012. Color modification for color-blind viewers using the dynamic color transformation. In: Consumer Electronics (ICCE), IEEE International Conference. <https://doi.org/10.1109/ICCE.2012.6162036>.
- Kotera, H. 2012. Optimal daltonization by spectral shift for dichromatic vision. *Color and Imaging Conference 2012* (1): 302-308. <http://www.ingentaconnect.com/content/ist/cic/2012/00002012/00000001/art00054>.

- Kulesza, J. A. 2018. Peacock. <https://github.com/jkulesza/peacock>.
- Machado, G. M., M. M. Oliveira, and L. A. F. Fernandes. 2009. A physiologically-based model for simulation of color vision deficiency. *IEEE Transactions on Visualization and Computer Graphics* 15 (6): 1291-1298. <https://doi.org/10.1109/TVCG.2009.113>.
- Machado, G. M. 2010. A model for simulation of color vision deficiency and a color contrast enhancement technique for dichromats. Federal University of Rio Grande do Sul.
- Meyer, G. W., and D. P. Greenberg. 1988. Color-defective vision and computer graphics displays. *IEEE Computer Graphics and Applications* 8 (5): 28-40.
- Milic, N., M. Hoffmann, T. Tomacs, D. Novakovic, and B. Milosavljevic. 2015. A content-dependent naturalness-preserving daltonization method for dichromatic and anomalous trichromatic color vision deficiencies. *Journal of Imaging Science & Technology* 59 (1): 10504-1-10504-10. <http://www.ingentaconnect.com/content/ist/jist/2015/00000059/00000001/art00007>.
- Shrestha, R. 2016. Simulating colour vision deficiency from a spectral image. *Universal Design 2016: Learning from the Past, Designing for the Future* 229: 392-401.
- Shrestha, R., and J. Y. Hardeberg. 2012. Computational color constancy using chromagenic filters in color filter arrays. *Sensors, Cameras, & Systems for Industrial/Scientific Applications XIII*.
- Shrestha, R., and J. Y. Hardeberg. 2012a. Simultaneous multispectral imaging and illuminant estimation using a stereo camera. In: *Image and signal processing*. Berlin: Springer, 45-55.
- Shrestha, R., and J. Y. Hardeberg. 2013. CFA based simultaneous multispectral imaging and illuminant estimation. In: *Computational Color Imaging*. Berlin: Springer, 158-170.
- Shrestha, R., and J. Y. Hardeberg. 2014. Spectrogenic imaging: A novel approach to multispectral imaging in an uncontrolled environment. *Optics Express* 22 (8): 9123-9133. <http://www.opticsinfobase.org/oe/abstract.cfm?uri=oe-22-8-9123>.
- Simon-Liedtke, J. T., and I. Farup. 2015. Spatial intensity channel replacement daltonization (SiChARdA). <http://dx.doi.org/10.1117/12.2079226>.
- Stockman, A., and L. T. Sharpe. 1999. Cone spectral sensitivities and color matching. In: *Color vision: From genes to perception*, K. Gegenfurtner and L. T. Sharpe, eds. Cambridge, UK: Cambridge University Press, 51-85.
- Wong, B. 2011. Points of view: Color blindness. *Nature Methods* 8 (6): 441.
- Xie, J. Z., K. Tarczy-Hornoch, J. Lin, S. A. Cotter, M. Torres, and R. Varma. 2014. Color vision deficiency in preschool children: The multi-ethnic pediatric eye disease study. *Ophthalmology* 121 (7): 1469-1474.
- Yang, S., Y. M. Ro, E. K. Wong, and J.-H. Lee. 2008. Quantification and standardized description of color vision deficiency caused by anomalous trichromats - part II: Modeling and color compensation. *Journal on Image and Video Processing* 2008 (3): 1-12. <http://dx.doi.org/10.1155/2008/246014>.

# Influence of the color of lighting on taste threshold

Hiroshi Takahashi\*, Daisuke Saito

Kanagawa Institute of Technology, Atsugi, Japan

\* htakahashi@ele.kanagawa-it.ac.jp

## ABSTRACT

We assess the flavor of food not only based on taste, but with all of our senses based on color, smell, texture and sound. However, there are few research reports on the relationship between environmental color and taste sensation. Therefore, in this study, we aimed to clarify the influence of the color of lighting on taste threshold sensitivity. In this experiment, red, green and blue colored lighting were used. Three kinds of taste solutions (sweet, salty and sour) were prepared at nine different concentration levels. In the case of sweet, the threshold was high under red lighting and low under green lighting. In the case of salty, no effect of lighting color was observed. In the case of sour, the threshold was high under green light and low under blue light.

*Keywords: light color, taste threshold, sweet, salty, sour*

## INTRODUCTION

We assess the flavor of food not only based on taste, but with all of our senses based on color, smell, texture and sound. Maga (1974) reported that the color green decreased the threshold sensitivity of tasting sweetness and increased the threshold sensitivity to tasting sourness and the color red increased the threshold sensitivity to tasting bitterness. Maga (1974) also reported that color did not significantly affect the threshold sensitivity to saltiness. Jin et al. (2005) reported that lighting was an important factor affecting taste sensation. However, there are few research reports on the relationship between environmental color and taste sensation. Therefore, in this study, we aimed to clarify the influence of the color of lighting on taste threshold sensitivity.

## EXPERIMENTS

In this experiment, red, green and blue colored lighting were used. The light colors used in this experiment are marked on the chromaticity diagram shown in Figure 1. The illuminance of the table surface was set to 200 lx. Three kinds of taste solutions (sweet, salty and sour) were prepared at nine

different concentration levels. Table 1 shows each solution concentration. The following procedure was used in the experiment:

- 1) Subjects were given 3 minutes to adapt to white lighting at 200 lx.
- 2) Subjects were given 3 minutes to adapt to the experimental lighting condition.
- 3) Taste threshold was measured.

The experiment was basically conducted once a day. However, when multiple experiments were conducted on the same day, we set an interval of more than 1 hour between experiments. To assess taste threshold, subjects tasted a taste solution at a specific concentration and were asked to select how the solution tasted from four choices of “sweet”, “salty”, “sour” and “I don’t know”. The presentation order of the concentration of the taste solution was as shown in Figure 2 with reference to the work of Jin et al. (2005) and Byung et al. (1997). One-factor analysis of variance (ANOVA) was performed in this study. The factor was lighting color, and multiple comparisons were performed using Fisher’s least significant difference method.

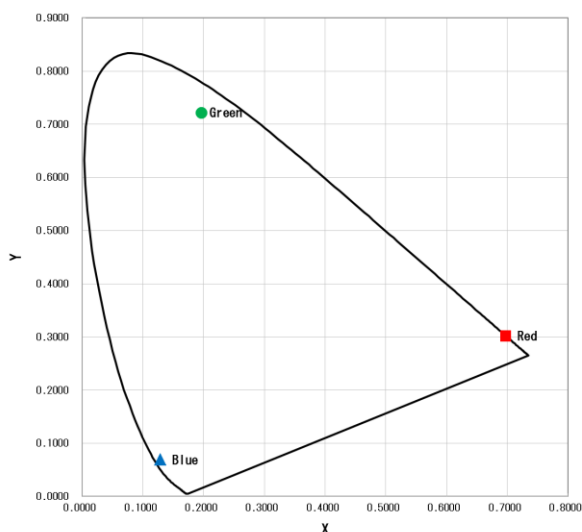

Figure 1: Experimental light colors on the CIE 1931 chromaticity diagram.

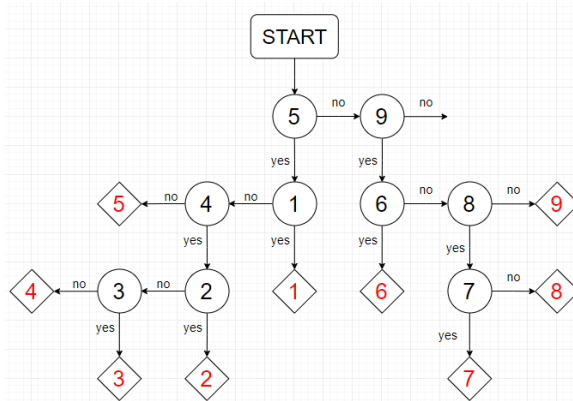

Figure 2: The presentation order of the concentration of the taste solution.

Concentration number	1	2	3	4	5	6	7	8	9
Sweet	0.1	0.15	0.2	0.25	0.3	0.35	0.4	0.45	0.5
Salty	0.05	0.075	0.1	0.125	0.15	0.175	0.2	0.225	0.25
Sour	0.0005	0.001	0.002	0.004	0.006	0.008	0.01	0.012	0.014

Table 1: Taste solution concentration (%).

## RESULTS AND DISCUSSION

Figure 3 shows the average of the taste thresholds of all subjects. It was found that light color caused a change in taste threshold. However, since the influence of individual differences was large, the

taste threshold was normalized. Figure 4 shows the average rate of change of the normalized taste threshold. Normalization was performed based on the average taste threshold of all colors of lighting for each subject. In the case of sweet, the threshold was high under red lighting and low under green lighting. In the case of salty, no effect of lighting color was observed. In the case of sour, the threshold was high under green light and low under blue light. ANOVA results showed a significant difference ( $p < 0.05$ ) between red and green lighting in the case of sweet. No significant difference was observed under the other conditions.

A similar trend in taste threshold by color was observed between this study and a previous study (Maga 1974) on different colored taste solutions. For sweet, the threshold was high for red and low for green. For sour, the threshold was high for green. For salty, no change in the threshold was observed due to the influence of color.

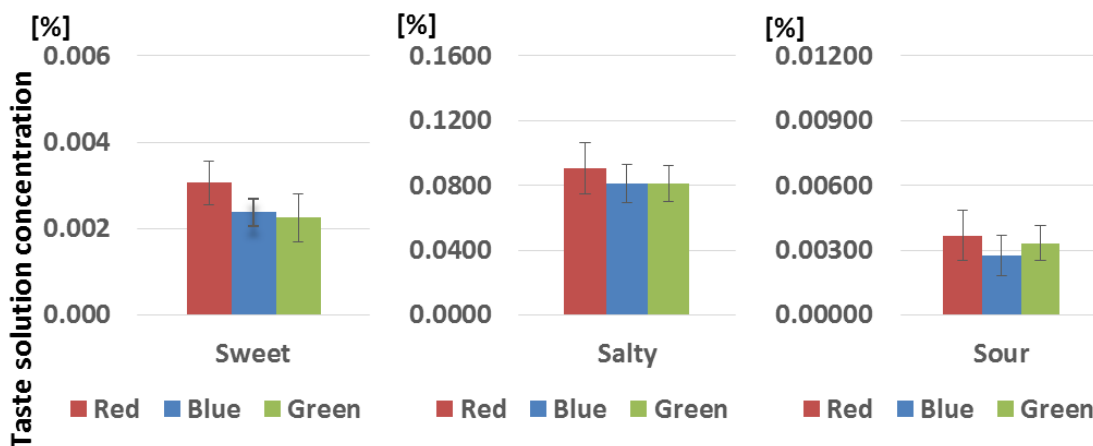

Figure 3: The average of the taste thresholds of all subjects.

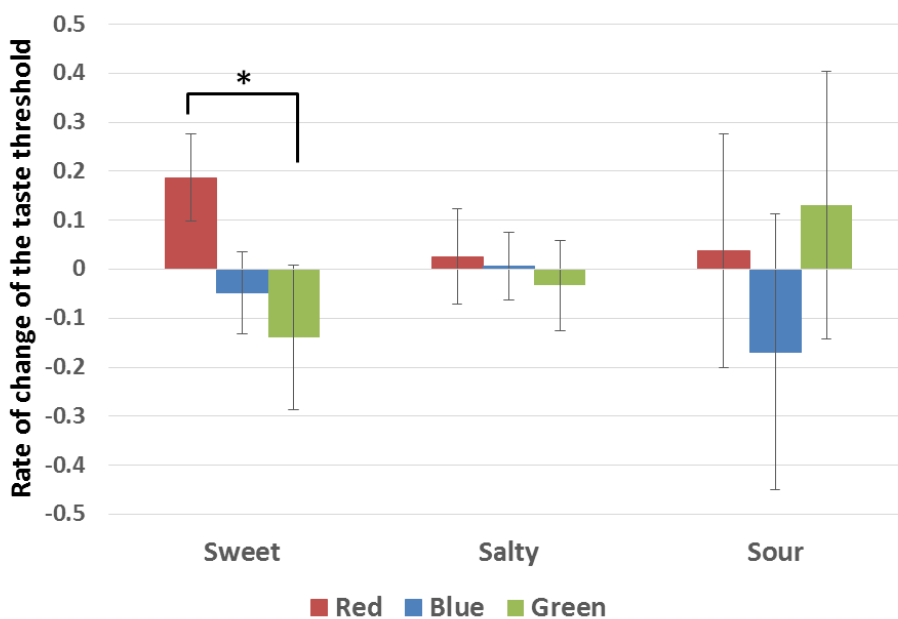

Figure 4: The average rate of change of the normalized taste threshold (\*represents a  $p < 0.05$ ).

## CONCLUSION

In this study, we examined the effect of lighting color on taste threshold. The results are summarized as follows:

- 1) Changes in taste threshold due to the color of lighting differ depending on taste.
- 2) The taste threshold for saltiness was not affected by the color of lighting.
- 3) Similar changes in taste threshold may occur between the case of changing the light color and changing the color of the taste solution.

## REFERENCES

- Byung, C. M., and K. Sakamoto. 1997. An analysis of gustatory evoked potentials for the four taste qualities with a special reference to individual taste thresholds. *The Japanese Journal of Taste and Smell Research* 4 (1): 43-54.
- Jin, X., T. Katsuura, K. Iwanaga, Y. Shimomura, and M. Inoue. 2005. Effects of different lighting on the amount of saliva and taste threshold in Japanese and Chinese. *Japanese Journal of Physiological Anthropology* 10 (1): 9-16.
- Maga, J. A. 1974. Influence of color on taste thresholds. *Chemical Senses and Flavor* 1: 115-119.

# Does melanopsin help to explain color constancy in natural environments?

Pablo A. Barrionuevo<sup>a\*</sup>, Dingcai Cao<sup>b</sup>

<sup>a</sup> Instituto de Investigación en Luz, Ambiente y Visión, CONICET - UNT, Tucumán, Argentina

<sup>b</sup> Department of Ophthalmology and Visual Sciences, University of Illinois, Chicago, IL, USA

\* pbarrionuevo@herrera.unt.edu.ar

## ABSTRACT

The aim of this work was to assess whether melanopsin excitation could help to achieve a better color constancy in natural environments.

Data from hyperspectral natural images and 21 daylight illuminants were used to compute L-, M-, S-cone and melanopsin excitations for each pixel. The geometrical distance in the cone chromaticity diagram  $[L/(L+M)$  and  $S/(L+M)]$  was computed between daylight illuminants and the reference illuminant (D65) for each pixel in each image. These distances were related to melanopsin excitation. Our analysis showed that to achieve a better color constancy, melanopsin contribution to afferent chromatic pathways depends on the correlated color temperature (CCT) of illuminants. For CCT values related to clear sky conditions, signals in the  $S/(L+M)$  axis need a positive melanopsin contribution, and the  $L/(L+M)$  axis a negative contribution. Instead, scenes such as those related with dawn and dusk, have worse constancy when melanopsin is considered.

**Keywords:** *color constancy, melanopsin, natural environment*

## INTRODUCTION

Human color vision in photopic conditions is mediated by three cone types (L, M and S). The cone excitations are conveyed by three post-receptoral pathways, including magnocellular (MC), parvocellular (PC) and koniocellular (KC) pathways, reviewed by Lee (2004). The MC-pathway combines L- and M-cone signals with the same sign to mediate luminance information. The PC-pathway combines L-cone and M-cone signals with opposite signs to provide red-green chromatic information. Finally, the KC-pathway combines S-cone signals in opposition to L- and M-cone signals to provide blue-yellow chromatic information.

Cones are not exclusive retinal photoreceptors detecting light in photopic conditions. In the beginning of this century, it was demonstrated that a group of retinal ganglion cells (ipRGCs) are intrinsically photosensitive (Berson et al. 2002, Hattar et al. 2002). These cells express the photopigment melanopsin (Provencio et al. 2000). IpRGCs projections include centers for non-image forming functions, but also the Lateral Geniculate Nucleus (LGN) and superior colliculus that are involved in image-forming visual processes (Hattar et al. 2003).

Color constancy is a perceptual ability by which we are able to maintain a relatively stable color perception to objects despite of changes in illumination (Foster 2011). This ability is important since color provides information about object properties (Brainard and Radonjić 2014).

Several models have been proposed trying to understand how the visual system achieves color constancy. These models can be classified as so-called lightness algorithms, estimators of the illumination spectrum, low-dimensional linear models, or Bayesian models, for a review see Foster (2011). However, most of the existing research thus far didn't focus on the statistical properties of natural environments (Arend 2001, Foster 2011).

Mice studies showed that melanopsin activation not only improves the LGN capacity to codify natural visual information and to work as an independent irradiance measurement to control visual adaptation in retinal level (Allen et al. 2014), but also a subset of LGN units can detect modest changes in irradiance employing melanopsin signals (Davis et al. 2015). Furthermore, macaque studies showed an important feature of melanopsin as an irradiance meter (Dacey et al. 2005). Therefore melanopsin may be a potential candidate for being involved in color constancy in natural environments. The objective of this exploratory analysis is to assess how melanopsin activation could help to achieve a better color constancy in natural environments.

## METHODS

### Natural images and illuminants

The excitation of each type of photopigment was computed from the combination of the reflectance of hyperspectral images with natural illuminants. Four hyperspectral images of rural scenes were downloaded from the website of Dr. David Foster's laboratory (<http://personalpages.manchester.ac.uk/staff/david.foster/default.htm>) (Foster et al. 2006). These images contain primordial foliage information and spectral reflectance information at each pixel. The scenes were acquired using a tunable bi-refringent filter mounted in front of the lens of a progressive-scanning monochrome digital camera (Nascimento et al. 2002), with image sizes of 820 pixels × 820 pixels. For this exploratory analysis we used a central patch of 800 pixels × 800 pixels (Figure 1a).

Natural daylight illumination was represented by 21 "D" illuminants with correlated color temperature (CCT) from 3600 K to 25,000 K (Linhares and Nascimento 2012), covering different phases of the day, from moon light to sun light (Wyszecki and Stiles 2000: 11, Stair and Johnston 1953). The spectral power distributions of the illuminants were normalized with the peak values of 1. The normalized illuminant spectral distributions are shown in Figure 1b.



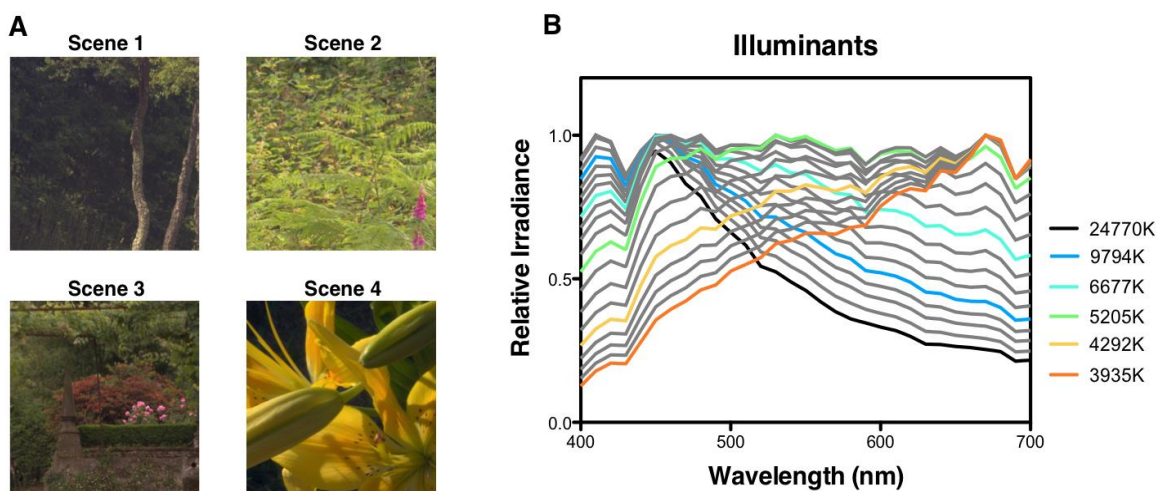

Figure 1:

- Scenes used for the computation of the cone and melanopsin chromaticities.
- Normalized daylight illuminants spectrum.

## Analysis

For each combination of illuminant and scene, the illuminant power was multiplied by the reflectance value at each wavelength between 400-700 nm in 10 nm steps to obtain the spectral radiance values at each pixel. We then computed the L-cone, M-cone, S-cone, and melanopsin-mediated ipRGC excitations for each pixel. The cone excitations (L, M, S) were computed based on the Smith and Pokorny (1975) cone fundamentals applied for the CIE 1964 10° standard observer.

The melanopsin-mediated ipRGC excitation ( $I$ ) was computed according to the melanopsin spectral sensitivity function (Enezi et al. 2011). The photoreceptor spectral sensitivity functions were normalized such that the areas under the curves were equal to 1.

We also computed the quantities  $l = L/(L+M)$ ,  $s = S/(L+M)$  and  $i = I/(L+M)$ . Note that  $l$  and  $s$  are two cardinal axes in a MacLeod & Boynton equiluminant cone chromaticity space (MacLeod and Boynton 1979), corresponding to the PC- and KC-pathways, respectively (Lee et al. 1990, Derrington et al. 1984). In such a space, luminance is specified as  $L+M$  because S-cones do not contribute to  $V(\lambda)$ . We used the same approach to normalize melanopsin excitations by cone luminance at each pixel.

Using D65 illuminant as a reference, the geometrical distance  $d$  in the cone chromaticity diagram ( $l$  vs  $s$ ) was computed between daylight illuminants and the reference illuminant for each pixel in each image. We also used an equal energy spectrum (EES) illuminant as the reference for a control purpose, which allowed representing the chromaticities of the objects in the scene. Distance  $d$  data were correlated to melanopsin chromaticities ( $i$ ) using different multiplicative coefficient for each cardinal axis. All of the analyses were carried out in MATLAB (Mathworks Inc.).

## RESULTS

### Rationale

Chromaticity values  $l$  and  $s$  for scene 1 are shown in Figure 2. Chromaticities considering the 21 illuminants form the blue data cloud ( $l_b, s_b$ ). While the red data cloud represent chromaticities ( $l_r$  and  $s_r$ ) considering only D65 illuminant (Figure 2, left) or EES illuminant (Figure 2, right). Therefore, a pixel ( $p_{xy}$ ) has one representation in the red cloud but 21 representations in the blue cloud. In order to achieve color constancy the illuminant effect should be discounted. The distance ( $d$ ) in the chromaticity diagram between a blue point for one illuminant ( $j$ ) and a red point for pixel ( $p_{xy}$ ) can be computed as  $d_l = l_{bj} - l_r$  and  $d_s = s_{bj} - s_r$ . If melanopsin helps to achieve color constancy discounting the illuminant effect, then  $d$  should be function of melanopsin excitation removing luminance ( $d = f(i_b)$ , Figure 3). We tested only the assumption that  $d$  is linearly related to melanopsin chromaticity. Therefore  $d$  and  $i$  are related by scaling factors  $F$ , i.e.,  $d = F * i_b$ .

Then:  $l_b = F_l * i_b + l_r$  (Eq. 1)

and  $s_b = F_s * i_b + s_r$  (Eq. 2)

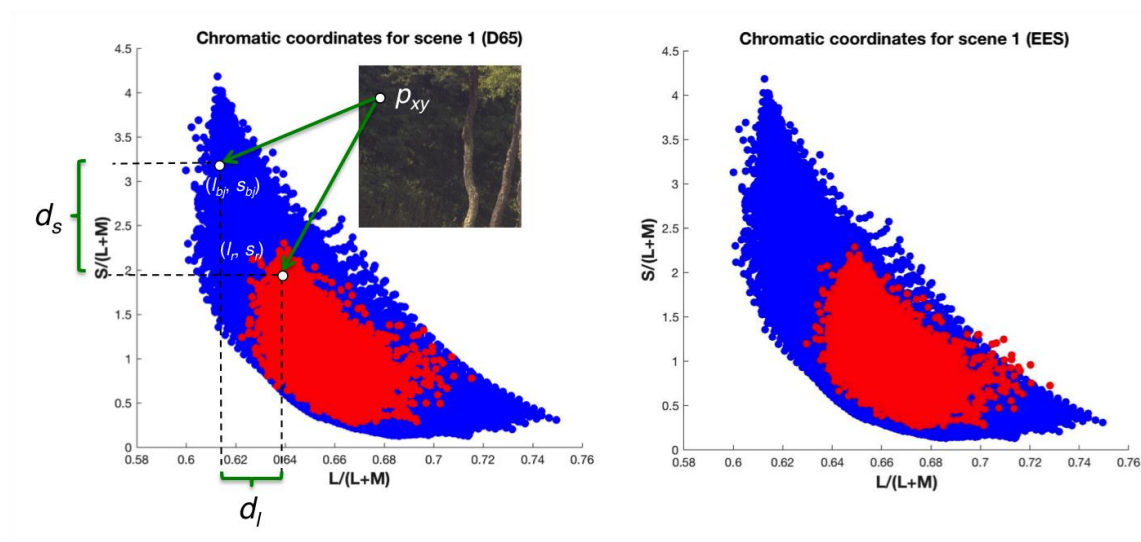

Figure 2:

Blue dots represent chromaticities for all illuminants computed by the reflectance of each pixel.

Red dots represent chromaticities computed considering only one illuminant, D65 or EES.

### Melanopsin excitation

Melanopsin excitation normalized by luminance ( $i$ ) results for the four scenes considering the 21 illuminants from lowest CCT value to highest CCT value are shown in Figure 3. As expected, the normalized melanopsin excitation increased in function of CCT of the illuminant for the four scenes.

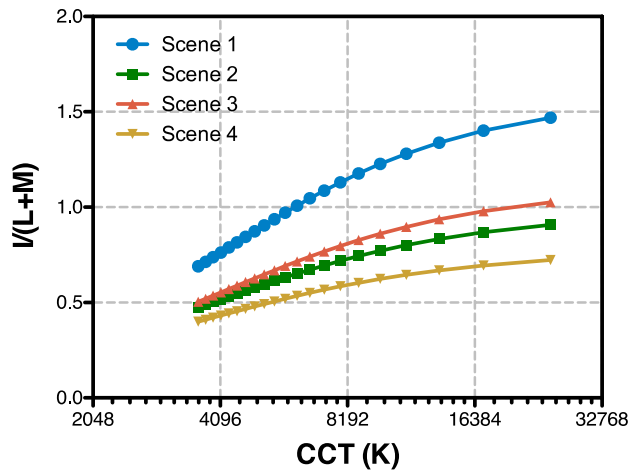

Figure 3: Averaged data of melanopsin excitation normalized by luminance in each pixel. Error bars are standard errors. Each panel represents the data for each scene.

### Factors

Factors  $F_s$  and  $F_l$  were computed for each scene following equation 1 and 2 respectively, considering D65 illuminant and EES illuminant as references ( $I_r, s_r$ ). Results are shown in Figure 4. For the four scenes, with increasing CCT value, the value of  $F_l$  that is needed in the  $I$  coordinate is reduced from positive to negative values, while the value of  $F_s$  factor increased from negative to positive values. Of course the zero value for  $F_l$  or  $F_s$  indicated when red points were equal to blue points in Figure 2.

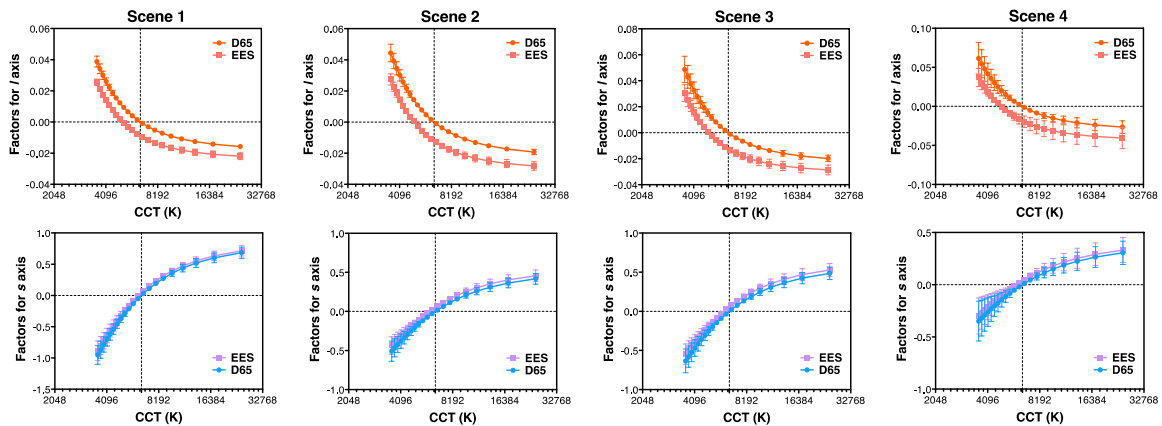

Figure 4: Factors for D65 and EES illuminants as references. Upper row panels contain factor values for  $I$  axis. Lower row panels contain factor values for  $s$  axis. Error bars are standard deviations.

### DISCUSSION

We showed that potential linear contribution of melanopsin to color constancy should affect in opposite ways the KC- and PC-pathways, but the sign depends on the CCT of the illuminant. For high CCT, a better color constancy requires that melanopsin has a positive contribution to the KC-pathway

but a negative contribution to the PC-pathway. For low CCT illuminants, however, a better color constancy requires that melanopsin has a negative contribution to the KC-pathway but a positive contribution to the PC-pathway. These results are similar either considering as reference a D65 Illuminant, which represents roughly a midday natural lighting conditions; or Equal energy spectrum illuminant, which give information about the spectral reflectance of the scene objects.

Part of this simple analysis is supported by previous studies. It has been shown that most of the reflectance variability in natural scenes is related to changes in luminance and in KC-signals (Ruderman et al. 1998, Barrionuevo and Cao 2014). We previously showed that melanopsin contributes positively to the MC and KC pathways (Barrionuevo and Cao 2014). Linear relation between melanopsin and KC-signals was demonstrated for pupil control (Barrionuevo and Cao 2016). According to these antecedents it is possible to think that melanopsin helps to achieve color constancy with high CCT illuminants, such as clear sky conditions.

Explanations about color constancy consist on cognitive, sensorial and computational components (Smithson 2005), suggesting that this visual ability is a multi-stage process. From an evolutionary perspective it is important to consider how illuminant changes in natural environments can be discounted, since constancy is better achieved under natural than artificial illumination (Lucassen and Walraven 1996). One possible explanation is considering melanopsin intrusion, since it has photon-counting properties (Dacey et al. 2005). Our exploratory analysis provides the possibility of the involvement of melanopsin in color constancy.

## ACKNOWLEDGEMENTS

Agencia Nacional de Promoción Científica y Tecnológica PICT 2016-3312 (PB). Consejo Nacional de Investigaciones Científicas y Técnicas P-UE 0114 ILAV (PB). Fulbright Visiting Scholar Program (PB). UIC core grant for vision research P30-EY001792, Unrestricted Departmental Grant (DC).

## REFERENCES

- Allen, A., R. Storchi, F. Martial, R. Petersen, M. Montemurro, T. Brown, and R. Lucas. 2014. Melanopsin-driven light adaptation in mouse vision. *Current Biology* 24 (21): 2481-2490.
- Arend, L. 2001. Environmental challenges to color constancy. In: *Human Vision and Electronic Imaging VI*, 4299. International Society for Optics and Photonics, 392-399.
- Barrionuevo, P., and D. Cao. 2014. Contributions of rhodopsin, cone opsins, and melanopsin to postreceptoral pathways inferred from natural image statistics. *Journal of the Optical Society of America A* 31 (4): 131-139.
- . 2016. Luminance and chromatic signals interact differently with melanopsin activation to control the pupil light response. *Journal of Vision* 16 (11): 29.
- Berson, D., F. Dunn, and M. Takao. 2002. Phototransduction by retinal ganglion cells that set the circadian clock. *Science* 295 (5557): 1070-1073.
- Brainard, D., and A. Radonjić. 2014. Color constancy. In: *The new visual neurosciences*, J. S. Werner and L. M. Chalupa, eds. Cambridge, MA: The MIT Press, 545-556.
- Dacey, D., H. Liao, B. Peterson, F. Robinson, V. Smith, J. Pokorny, K. Yau, and P. Gamlin. 2005. Melanopsin-expressing ganglion cells in primate retina signal colour and irradiance and project to the LGN. *Nature* 433 (7027): 749-754.

- Davis, K., C. Eleftheriou, A. Allen, C. Procyk, and R. Lucas. 2015. Melanopsin-derived visual responses under light adapted conditions in the mouse DLGN. *PLOS ONE* 10 (3): e0123424.
- Derrington, A., J. Krauskopf, and P. Lennie. 1984. Chromatic mechanisms in lateral geniculate nucleus of macaque. *The Journal of Physiology* 357 (1): 241-265.
- Enezi, J., V. Revell, T. Brown, J. Wynne, L. Schlangen, and R. Lucas. 2011. A 'melanopic' spectral efficiency function predicts the sensitivity of melanopsin photoreceptors to polychromatic lights. *Journal of Biological Rhythms* 26 (4): 314-323.
- Foster, D. 2011. Color constancy. *Vision Research*, Vision Research 50th Anniversary Issue: Part 1, 51 (7): 674-700.
- Foster, D., K. Amano, S. Nascimento, and M. Foster. 2006. Frequency of metamerism in natural scenes. *Journal of the Optical Society of America A* 23 (10): 2359-2372.
- Hattar, S., H. Liao, M. Takao, D. Berson, and K. Yau. 2002. Melanopsin-containing retinal ganglion cells: architecture, projections, and intrinsic photosensitivity. *Science* 295 (5557): 1065-1070.
- Hattar, S., R. Lucas, N. Mrosovsky, S. Thompson, R. Douglas, M. Hankins, J. Lem, M. Biel, F. Hofmann, R. Foster, and K. Yau. 2003. Melanopsin and rod-cone photoreceptive systems account for all major accessory visual functions in mice. *Nature* 424 (6944): 75-81.
- Lee, B. 2004. Paths to colour in the retina. *Clinical and Experimental Optometry* 87 (4-5): 239-248.
- Lee, B., J. Pokorny, P. Martin, A. Valberg, and V. Smith. 1990. Luminance and chromatic modulation sensitivity of macaque ganglion cells and human observers. *Journal of the Optical Society of America A* 7 (12): 2223-2236.
- Linhares, J., and S. Nascimento. 2012. A chromatic diversity index based on complex scenes. *Journal of the Optical Society of America. A, Optics, Image Science, and Vision* 29 (2): A174-181.
- Lucassen, M., and J. Walraven. 1996. Color constancy under natural and artificial illumination. *Vision Research* 36 (17): 2699-2711.
- MacLeod, D., and R. Boynton. 1979. Chromaticity diagram showing cone excitation by stimuli of equal luminance. *Journal of the Optical Society of America* 69 (8): 1183-1186.
- Nascimento, S., F. Ferreira, and D. Foster. 2002. Statistics of spatial cone-excitation ratios in natural scenes. *Journal of the Optical Society of America. A, Optics, Image Science, and Vision* 19 (8): 1484-1490.
- Provencio, I., I. Rodriguez, G. Jiang, W. Hayes, E. Moreira, and M. Rollag. 2000. A novel human opsin in the inner retina. *The Journal of Neuroscience* 20 (2): 600-605.
- Ruderman, D., T. Cronin, and C. Chiao. 1998. Statistics of cone responses to natural images: implications for visual coding. *Journal of the Optical Society of America A* 15 (8): 2036-2045.
- Smith, V., and J. Pokorny. 1975. Spectral sensitivity of the foveal cone photopigments between 400 and 500 nm. *Vision Research* 15 (2): 161-171.
- Smithson H. 2005. Sensory, computational and cognitive components of human colour constancy. *Philosophical Transactions of the Royal Society B: Biological Sciences* 360 (1458): 1329-1346.
- Stair, R., and R. Johnston. 1953. Ultraviolet spectral radiant energy reflected from the Moon. *Journal of Research of the National Bureau of Standards* 51: 81-84.
- Wyszecki, G., and W. S. Stiles. 2000. *Color science: concepts and methods, quantitative data and formulae*, 2nd ed. New York: John Wiley & Sons.

# Pupil role in color brightness perception in relation with “the dress” explanations

Andrés Martín<sup>ab\*</sup>, Juan Ignacio Contino<sup>a</sup>

<sup>a</sup> Instituto de Investigación en Luz, Ambiente y Visión (ILAV), Universidad Nacional de Tucumán (UNT)  
Consejo Nacional de Investigaciones Científicas y Técnicas (CONICET), Tucumán, Argentina

<sup>b</sup> Universidad Tecnológica Nacional (UTN), FRT, Tucumán, Argentina

\* amartin@herrera.unt.edu.ar

## ABSTRACT

It is well known that pupil size is determined mainly by the illumination level and that the entire pupil's reflex mechanism is controlled by the sympathetic and parasympathetic nerves, in an almost exclusively bottom up fashion. On the other hand, it is a less known issue how the pupil size affects perception, and in particular, color perception. Recent studies, triggered since “the dress” image was scientifically considered by the vision community, suggest that pupil size plays an important role in the perception of brightness of colored patches. Our research suggests the existence of two groups of observers: those who have a “big pupil” and perceive colors in a dimmer way and those who have a “small pupil” and perceive colors in a brighter way. Further analysis is needed to grasp these results in a family theoretical framework.

**Keywords:** *pupil size, brightness perception, color perception, “the dress”*

## INTRODUCTION

In a recent study, Vemuri et al. (2016) have shown that the average pupil size in observers who reported seeing the colors of the dress as black / blue were significantly higher than those who perceived the dress as white / gold. The authors conclude that there is evidence supporting the use of the way observers perceived the colors of the dress as a grouping factor that explains some pupil size differences among observers. However, as the researchers expected to find a “differential response to colors from the lower or higher wavelengths (blue or red)” according to this grouping factor, they arranged an experimental set up where color luminances were allowed to vary. This luminance variation has a disadvantage at the moment of pupil size measurement: it blends the effects of luminance and color. Therefore, to analyze how much membership in one of these groups contributes to the size of the pupil, such an experimental design generates data with a lot of noise.

To quantify the effect of belonging to one of these groups on pupil size, we designed an experimental set up where we kept luminance constant. In this way we can isolate and quantify the differences in pupil size for both groups which would allow us to calculate the differences in retinal illuminance. Finally, our hypothesis is that this change in retinal illuminance would play a role in the perception of the dress colors.

## **EXPERIMENT**

To perform this study, we use a high power projector. Onto the center of a screen we displayed a circular stimuli of 10° field of view. Ten different hues at four different luminance values (4, 20, 40 and 80 cd/m<sup>2</sup>) have been used as test stimuli. One equal-energy white stimulus with an equivalent luminance was added to be used as a reference. All the stimuli were characterized through a spectroradiometer. The background was maintained always black (2 – 4 cd/m<sup>2</sup>). Forty test stimuli were presented to each observer randomly, always alternating with the reference stimulus. The perceived brightness was evaluated with the magnitude estimation method, in which the observers must estimate the brightness of the test stimuli by assigning numerical values relative to the perceived brightness of the reference stimulus (that has preassigned a brightness value of 100). Pupil size was measured using an EyeTracker while each observer was doing the brightness estimation.

## **RESULTS AND DISCUSSION**

Figure 1 shows the pupil size (y axis) across luminance range (panels) and for each displayed color (x axis). Dots colors encodes the way observers perceive the dress: blue dots for Gold/White; red dots for Black/Blue.

In general, pupil behaves as expected: increasing the luminance causes smaller pupils. However, the first panel shows a clear differentiation between the groups. Those who perceive the dress in “dark” colors have, in general, a larger pupil than those who perceive the dress in “light” colors. This result is similar to that reported by Vemuri et al. (2016) (Figure 1a) for luminances of around 1 cd/m<sup>2</sup>. Therefore, our results combined with theirs suggest that, whatever the mechanism that is causing the group differentiation according to the perception of the dress, its operation depends on the luminance and its effect on pupil size can be recorded with low luminances.

On the other hand, we show on Figure 2 the results of brightness perception. Color codes are the same: red dots for observers who perceive a black/blue dress and blue ones for those who perceive the dress as gold/white.

A visual inspection of Figure 2 reveals the obvious: regardless of the luminance level of the stimuli, perceived brightness is the same for the two hypothesized groups. It is important to highlight that in our experimental set up, the judgment of color brightness were made in an unrelated way. This experimental detail is key to understanding the difference with what was reported in other works (e.g. Gegenfurtner et al. 2015, Lafer-Sousa et al. 2015, Witzel et al. 2017), where it is stated that between the groups there is a difference in the perception of brightness.

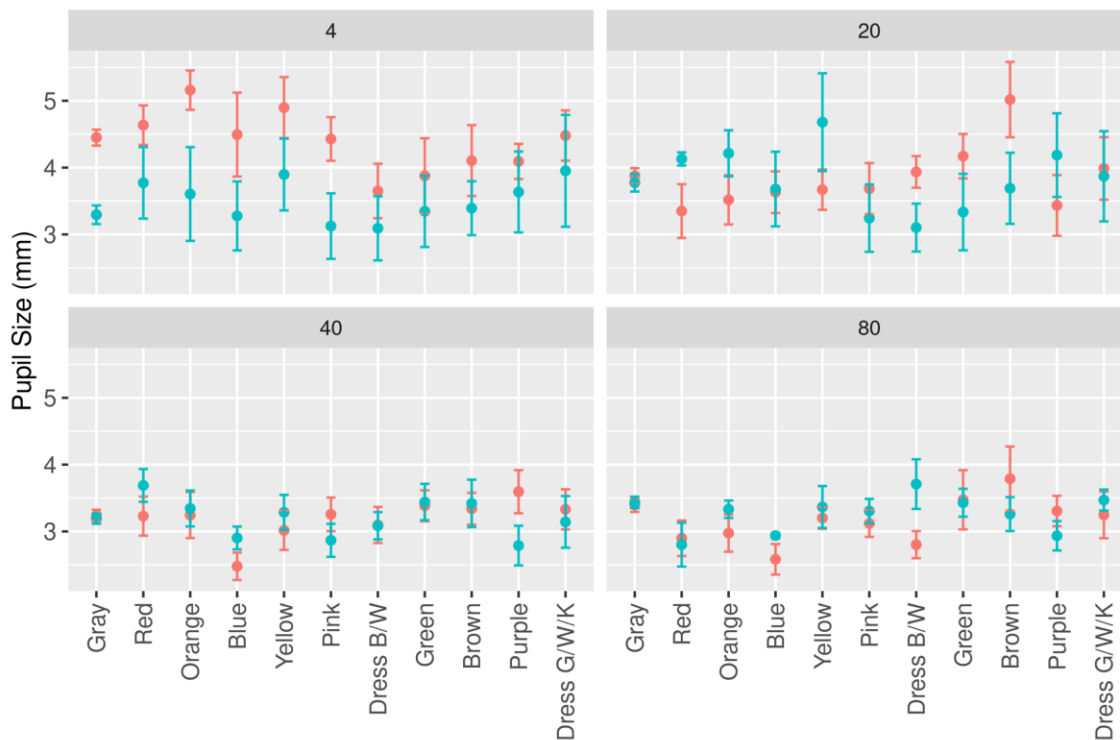

Figure 1: Pupil size depending on the luminance (panels) and the color stimuli. Errors lines represent one standard error above and below the mean. Dot colors encodes how the observers perceive the dress: red dots, Black / Blue; blue dots, Gold / White. Each dot was obtained from at least three seconds of pupil size measurement.

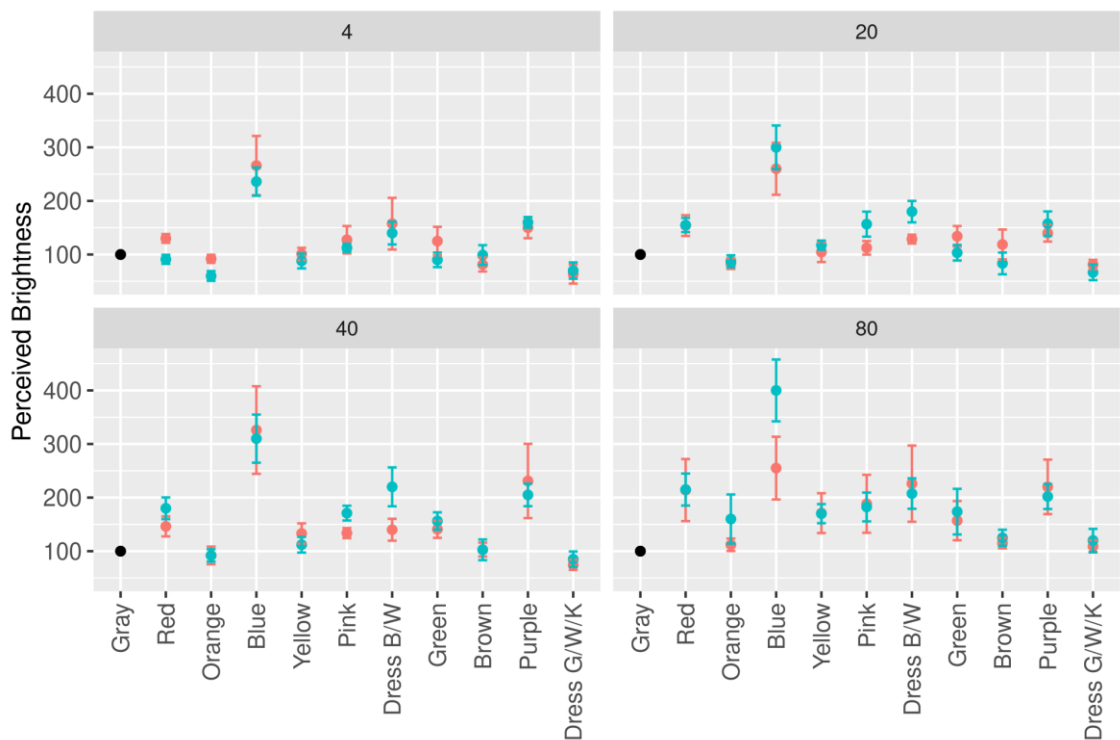

Figure 2: Perceived brightness depending on the luminance (panels) and the color stimuli. The reference was a gray stimulus (black dot) that has preassigned a brightness value of 100. Errors lines represent one standard error above and below the mean. Dot colors encodes how the observers perceive the dress: red dots, Black / Blue; blue dots, Gold / White.



## CONCLUSION

We think there is enough evidence to claim the existence of two people groups: those who have "small" pupils and those who have "larger" pupils. Until the irruption of the dress image, there was no way to classify which category each individual belongs to, which is possible today. Far from being innocuous, belonging to one of these groups has consequences on how colors are perceived.

It remains to investigate what is the origin of these groups and the mechanism by which they affect the perception of color.

## REFERENCES

- Gegenfurtner, K. R., M. Bloj, and M. Toscani. 2015. The many colours of "the dress". *Current Biology* 25 (13): R543-R544. <https://doi.org/10.1016/j.cub.2015.04.043>.
- Lafer-Sousa, R., K. L. Hermann, and B. R. Conway. 2015. Striking individual differences in color perception uncovered by "the dress" photograph. *Current Biology* 25 (13): R545-R546. <https://doi.org/10.1016/j.cub.2015.04.053>.
- Vemuri, K., K. Bisla, S. Mulpuru, and S. Varadharajan. 2016. Do normal pupil diameter differences in the population underlie the color selection of "the dress". *Journal of the Optical Society of America A* 33 (3): A137. <https://doi.org/10.1364/JOSAA.33.00A137>.
- Witzel, C., C. Racey, and J. K. O'Regan. 2017. The most reasonable explanation of "the dress": Implicit assumptions about illumination. *Journal of Vision* 17 (2): 1. <https://doi.org/10.1167/17.2.1>.

# Improving the appearance of HDR images based on visual characteristics

Shogo Nishi\*, Takuto Katanozaka

Osaka Electro-Communication University, Neyagawa, Japan

\* s-nishi@osakac.ac.jp

## ABSTRACT

The present paper proposes an image reproduction method based on visual characteristics using an image appearance model. We proposed two kinds of tone compression methods and realized the gradation control of an HDR scene image by integrating into the conventional method. In the experiment, 40 HDR images were used. These images were classified according to the brightness and composition of the scene, and the proposed method was evaluated. As a result of tone compression by the proposed method, it was confirmed that the unnatural luminance change in the output image was suppressed and it became a natural appearance image. Furthermore, the effectiveness of the proposed method was shown by conducting subjective evaluation experiments.

**Keywords:** *high dynamic range image, tone compress, visual characteristic*

## INTRODUCTION

The cityscape has mainly been considered about the daytime view, but nowadays urban activities are carried out day and night. Therefore, nighttime view is also considered as an important aspect to form a cityscape. The use of images has become commonplace in the formation and maintenance of cityscape. However, it is well known that the cityscape image acquired by the camera and human perception are different. This is because human vision understands scene information through non-linear processing such as chromatic adaptation and brightness adaptation. Furthermore, in both daytime urban landscape and nighttime urban landscape, there is a region where the contrast ratio is large. Because the dynamic range of the human visual system and color devices are different, high dynamic range (HDR) imaging is used to acquire images of such areas. However, since the dynamic range of a general display is 8 bits, it is necessary to finally perform tone mapping to a low dynamic range (LDR) image. Therefore, it is necessary to develop a method for reproducing the appearance of an HDR scene image taking visual characteristics into consideration.

In this research, we propose an image reproduction method based on visual characteristics using an image appearance model. We considered iCAM06 (Kuang et al. 2007) as a conventional method

for the image appearance model. We proposed two kinds of tone compression methods and realized the gradation control of an HDR scene image by integrating into the conventional method.

## THEORY

### Acceleration of image decomposition

In the framework of the proposed method, the input image is decomposed into two layers (Durand and Dorsey 2002). In the conventional method, the image is decomposed into the Base-layer which applies the bilateral filter to the input image and the Details-layer which is the difference image between the input image and the Base-layer. The time required for image decomposition occupies much of the entire processing time, and the trend of enhancing resolution of images in recent years is remarkable. Therefore, we considered it was important to speed up image decomposition. Therefore, in this study, the bilateral filter with the time complexity  $O(Nr^2)$  is replaced with the guided filter (He et al. 2013) with the time complexity  $O(N)$  to speed up the processing, where  $N$  represents the number of pixels and  $r$  represents the radius of the filter size.

### Generation of a local adapted white image reflecting scene features

In the conventional method, the compression ratio is calculated based on the local adapted white image generated by a Gaussian blur, and tone compression is performed. Although the kernel size of the Gaussian filter depends on the image size, it has been confirmed that using the default value for some scene images produces unnatural results. Therefore, we thought that the appearance can be improved by reflecting the scene features in the local adapted white image. The unnatural appearance images were especially noticeable in scenes with strong light sources. Therefore, as an improvement method, we propose a method to generate the local adapted white image that reflects the features of the scene by applying a guided filter with the input image as the guide image (method 1).

### Integration of retinal response model

Since local adapted white images depend on the observation conditions, it is sometimes difficult to set accurate parameters. In addition, because humans have various adaptation characteristics, the visual response is complicated and accurate modeling is difficult. Therefore, instead of using locally adapted white images, we will consider the use of a retinal response model obtained from physiological experiments (method 2). This model is proposed to explain the response of the fish retina (Naka and Rushton 1966). The output  $R(I)$  is expressed by the following equation.

$$R(I) = R_{max} \frac{I^n}{I^n + \sigma^n} \quad (1)$$

where  $I$  represents the intensity of incident light, and the Y value of the tristimulus XYZ image is given in the actual calculation.  $\sigma$  is the semi-saturation constant, and  $n$  is the sensitivity coefficient. The output  $R(I)$  is normalized from 0 to 1.  $R_{max}$  is set to 1 for simplicity (Reinhard and Devlin 2005). The response curve of luminance and visual response can be shifted by the semi-saturation constant, and the adaptation effect can be predicted. Furthermore, the sensitivity is adjusted according to the scene using the sensitivity coefficient. In addition, by introducing this model, the local adapted white image becomes unnecessary, and it is possible to prevent unnatural luminance change caused by conventional tone compression.

## EXPERIMENTAL RESULTS

An evaluation experiment of the conventional method and the two proposed methods (method 1, method 2) was conducted. In the experiment, 40 HDR images<sup>1</sup> were used. These 40 images were classified into scenes such as “bright”, “dark”, “indoor”, etc., and the experiment was conducted. The output results of each method are shown in Figures 1 and 2. The conventional model feels bright overall, and the area of the stone pillar at the bottom (front) of the image looks particularly bright in Figure 1. On the other hand, method 1 and method 2 suppress this unnatural luminance change. Especially in method 2, the output result seems to be close to actual perception. The same phenomenon was confirmed in Figure 2.

Next, the evaluation experiment by the paired comparison method was performed. The display used in the experiment was EIZO Color Edge CG 2420, and the evaluation was carried out in the dark room. The subjects were seven male and one female student. Two images were displayed to the subjects, and they were asked to evaluate which of them seemed natural as a perception of the scene. The results are shown in Figure 3. The vertical axis in Figure 3 indicates the percentage of people who have been evaluated. When comparing the conventional method with method 1, the conventional method was superior in “bright” scenes. On the other hands, the proposed method was excellent in indoor and strong light source scenes. It is conceivable that the filter size for generating the local adapted white image has an influence. Therefore, it is considered that the local adapted white image reflecting the features of the scene worked effectively. The comparison between the conventional model and method 2 showed that method 2 was superior in all scene classifications, especially in indoor scenes. Similar results were obtained by comparing method 1 and method 2. It was shown that good tone compression was performed and an output image corresponding to the scene was obtained.

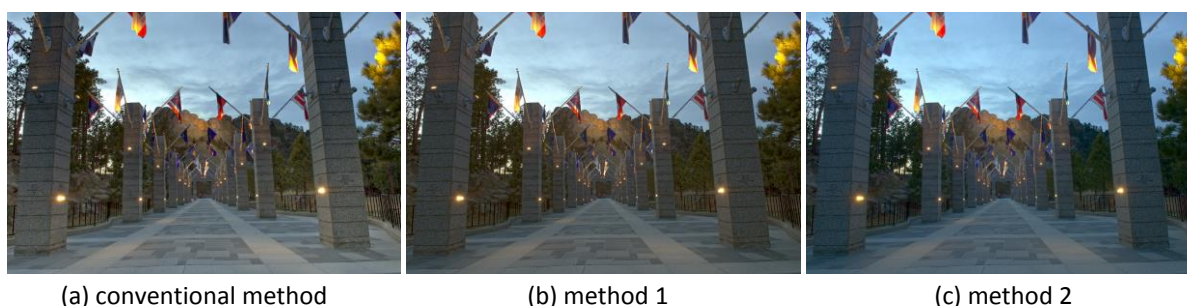

Figure 1: Experimental results in the “dark” scene.

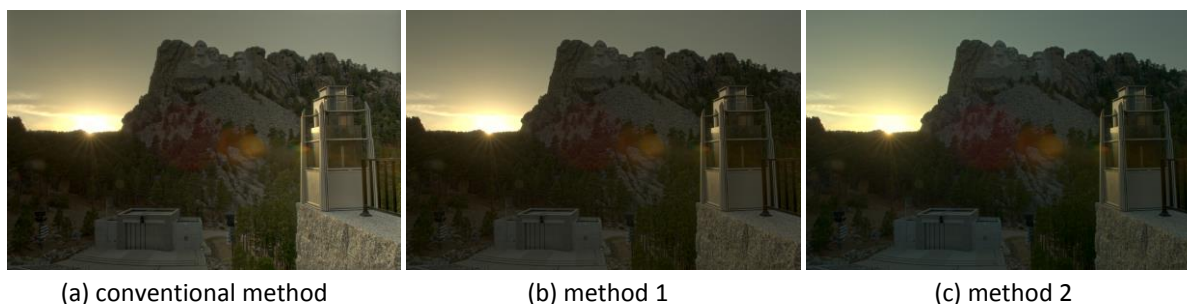

Figure 2: Experimental results in the “strong light source” scene.

<sup>1</sup> The HDR Photographic Survey : <http://rit-mcsl.org/fairchild//HDR.html>.

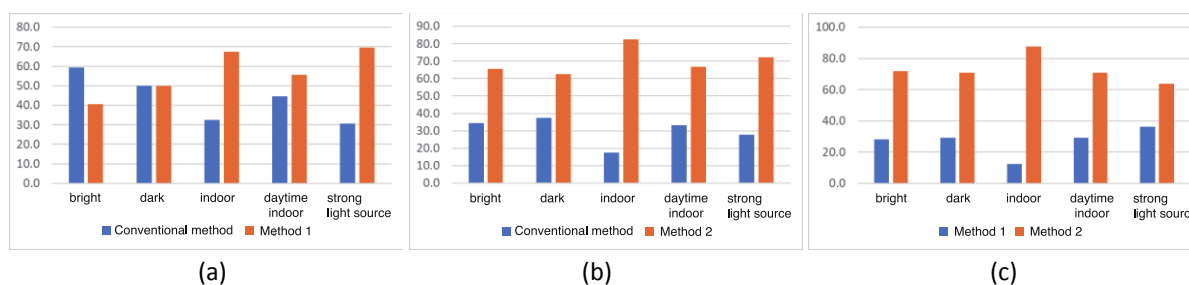

Figure 3: Evaluation results by paired comparison method; (a) conventional method vs method 1, (b) conventional method vs method 2, (c) method 1 vs method 2.

In method 1 and method 2, the guided filter was adopted for the efficiency improvement of the processing. By replacing the filter, the calculation cost was reduced, and the filter processing time was shortened by about 22 seconds. In addition, the overall processing time was shortened, and the ratio of the filter processing time to the total processing time decreased from 49.6% to 22.99%.

## CONCLUSION

We proposed a method for improving the appearance of landscape images in HDR scenes based on visual characteristics. A tone compression method that reflects the features of the scene in a locally adapted white image and a tone compression method based on physiological experiments were proposed. It was confirmed that the proposed method suppresses unnatural luminance changes and produces natural appearance images. Especially, it was shown to be effective in indoor and strong light source scene. Moreover, efficient processing could be realized by replacing the filter. On the other hand, in the present evaluation experiment, the landscape image that can be directly confirmed by the subject was not used, and it cannot be said that sufficient evaluation verification was performed. In the future, the above issues will be addressed.

## ACKNOWLEDGEMENTS

This work was partially supported by JSPS KAKENHI Grant Number 17K00254.

## REFERENCES

- Durand, F., and J. Dorsey. 2002. Fast bilateral filtering for the display of high-dynamic-range images. *ACM Transactions on Graphics (TOG)* 21: 257-266.
- He, K., J. Sun, and X. Tang. 2013. Guided image filtering. *IEEE Transactions on Pattern Analysis and Machine Intelligence* 35: 1397-1409.
- Kuang, J., G. M. Johnson, and M. D. Fairchild. 2007. iCAM06: A refined image appearance model for HDR image rendering. *Journal of Visual Communication and Image Representation* 18: 406-414.
- Naka, K. I., and W. A. H. Rushton. 1966. S-potential from colour units in the retina of fish (cyprinidae). *Journal of Physiology* 185: 536-555.
- Reinhard, E., and K. Devlin. 2005. Dynamic range reduction inspired by photoreceptor physiology. *IEEE Transactions on Visualization and Computer Graphics* 11: 13-24.

# Color Science and Technology



# Color reproduction problems of telemedicine with the use of smartphone

Yuki Akizuki<sup>a\*</sup>, Takahiro Goto<sup>a</sup>, Futoshi Ohyama<sup>b</sup>, Satoshi Iwamoto<sup>b</sup>

<sup>a</sup> University of Toyama, Toyama, Japan

<sup>b</sup> Tokai University, Isehara, Kanagawa, Japan

\* akizuki@edu.u-toyama.ac.jp

## ABSTRACT

In Japan, the medical practice with communication equipment as computer, facsimiles and mobile telephones (telemedicine) is on the way as part of efforts to tackle super-aging society and doctor shortage. But the latest OLED smartphone displays have the wider color gamut and it may produce different color appearance from actual color. Therefore, this research examined the color reproduction problems of telemedicine with the use of smartphone. In this experiment, the latest smartphone with OLED display was used. 24 chips of the GretagMacbeth ColorChecker and photoprints of decubitus were used as visual targets. Under lower color temperature lighting conditions than 3000 K such as incandescent lamp, color reproduction of the smartphones display was not good. Brightness and saturation on the smartphone display tended to express higher than the real color. Therefore, the judgement of decubitus symptom by using smartphone's images might be over evaluated and misconstrued.

**Keywords:** telemedicine, smartphone, color reproduction, color appearance

## INTRODUCTION

Smartphone has been spreading explosively since 2010 everywhere in the world. In Japan, most young people in their 20s have at least one smartphone. The common operating system of smartphone used in the world is Android OS, but iOS for Apple iPhone has a 70% share in Japan.

Smartphone display has advanced by means of technological innovation. The organic light-emitting diodes (OLED) are used for smartphone displays in 2018, and they have higher definition with larger size, higher luminance and deeper black, higher contrast and higher visibility, and wider color gamut. On the other hand, a problem about color appearance of OLED smartphone displays occurs. The wider color gamut by OLED smartphone displays may lead to excessive color representation like cinema film. And it may produce different color appearance from actual color.

In Japan, the medical practice with communication equipment as computer, facsimiles and mobile telephones (telemedicine) is on the way as part of efforts to tackle super-aging society and doctor shortage. Usually a doctor examines/sees a patient face-to-face. As treatment in the chronic phase for some significant period, the doctor can use telemedicine methods as complementary practices. The color reproduction of telemedicine communication equipment become a challenge to dermatological treatment such as decubitus care and atopic dermatitis.

This research examined the color reproduction problems of telemedicine with the use of smartphone. The medical data such as images of the affected parts are handled carefully in term of the individual information protection policy. But some medical staffs use smartphone for recording the affected parts to collect personal observation data for better medicine and surgery supports. And they sometimes discuss the treatment strategy with their colleagues in person while viewing the data. In telemedicine treatment, frequency of smartphone use will become even greater.

## EXPERIMENTS

The experiment was carried on a dark room at Faculty of Human development of University of Toyama, without the sunlight coming in from the windows.

iPhone XS Max made in 2018 was used in this experiment. The smartphone is the latest one. The display size of 6.5 inch was the biggest at that time in the world. The display resolution was  $2688 \times 1242$  pixel (458 pixels per inch). The OLED were used for its displays.

“REALAPS 2.0+Clum Color system” made by Visual Technology Laboratory in Japan was used in this experiment as measuring equipment for color tristimulus values of CIE-XYZ two-dimensionally. The calculation program of “REALAPS 2.0+Clum Color system” was running under Windows 10. A digital camera “Lumix-GX7” made by Panasonic was included for the standard specification of the system. The camera’s conditions were set as the shutter speed to 1/30, the aperture of f/4, and the sensitivity ISO-200.

In a darkroom, the visual targets were illuminated at 500 lx by six kinds of light sources; an incandescent lamp of 2468 K, three fluorescent lamps of 2832 K, 5064 K, 6458 K, and two LED lamps of 2651 K and 5041 K. The spectral power distributions of these light sources are shown in Figure 1. These data were measured by an illuminance spectrophotometer CL-500A (Konica Minolta).

For this experiment, 24 chips of the GretagMacbeth ColorChecker and photoprints of decubitus (Igaku Syuppan 2016) were used as visual targets. The decubitus photoprints and spectral reflectance of two typical patients are shown in Figure 2. The spectral reflectance data of 24 chips of the GretagMacbeth ColorChecker were also measured by a portable spectrophotometers CM-2600d (Konica Minolta).

The experimental procedure is outlined below.

- 1) Take images of visual targets by “Lumix-GX7” under a certain light source.
- 2) Take images of visual targets by iPhone under the same light source.
- 3) Take images of the iPhone’s display which shows each visual target images by “Lumix-GX7” without the light.
- 4) Read color tristimulus values of CIE-XYZ in the images of procedure 1 and procedure 3 by using “REALAPS 2.0+Clum Color system”.
- 5) Calculate CIE-L\*a\*b\* and C\*ab from CIE-XYZ of “REALAPS 2.0+Clum Color system”.
- 6) Experiment under other light sources following from procedure 1 to procedure 5.



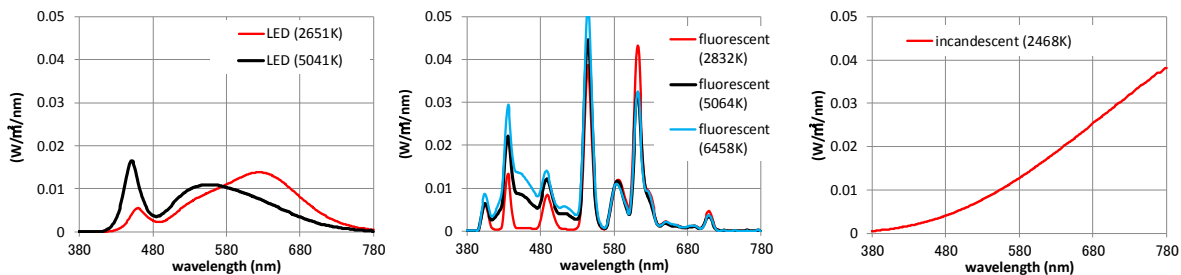
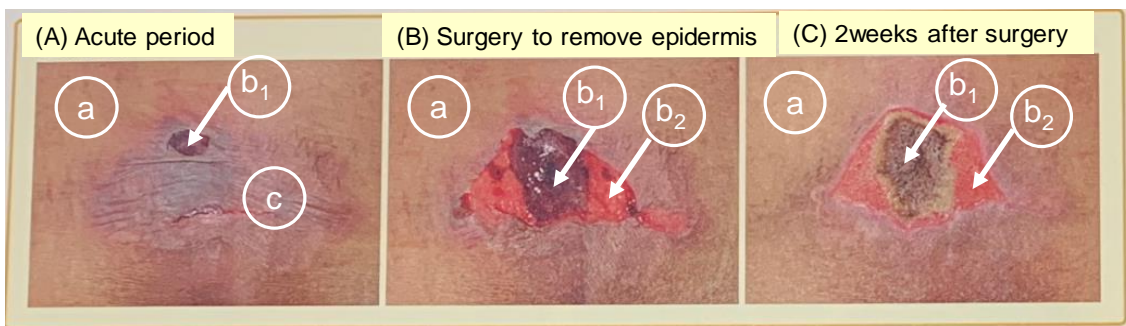
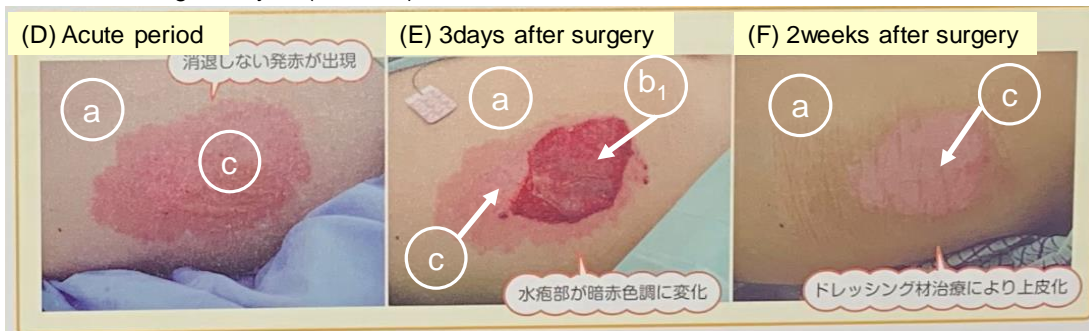

Figure 1: Spectral power distributions of light sources.

Elderly subject (79, female)



Midlife overweight subject (47, male)



a=skin, b1&b2=exposed affected area, c=bulged epidermis skin

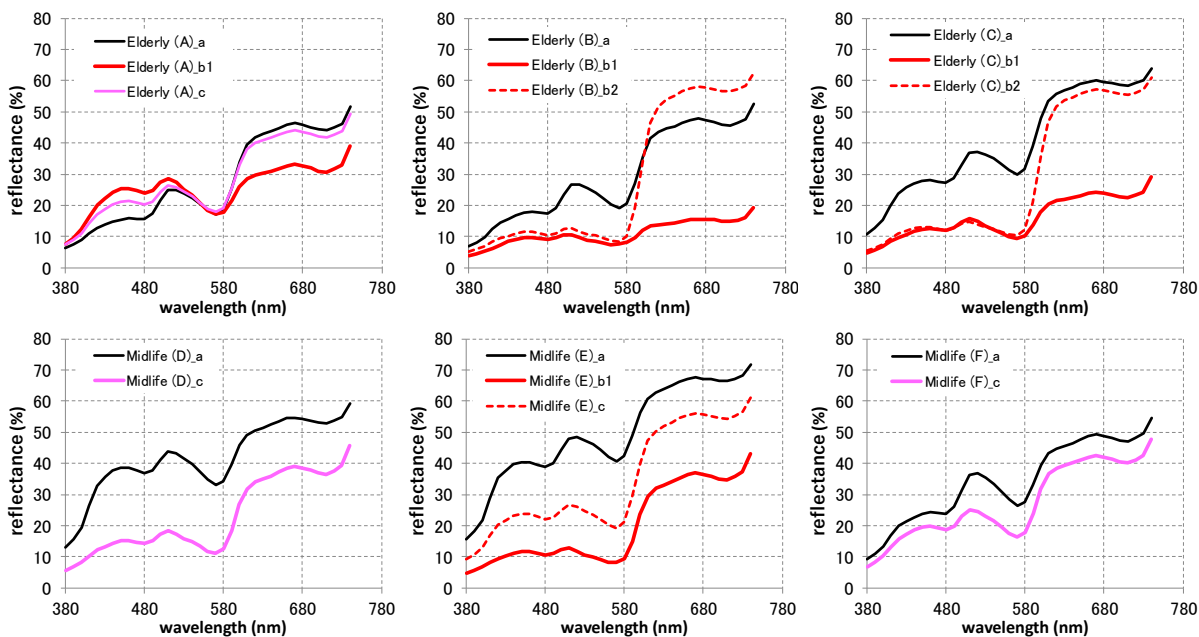

Figure 2: Decubitus photoprints and spectral reflectance of two typical patients (Igaku Syuppan 2016).

## RESULTS AND DISCUSSION

“REALAPS 2.0+Clum Color system” is developed for inexpensive and readily available experiment to measure color tristimulus values of CIE-XYZ two-dimensionally, but the accuracy of measurement is not precise enough. Therefore, we also calculated the theoretical CIE-XYZ with the spectral power distributions data of light sources (Figure 1) and the spectral reflectance data of visual targets (Figure 2) by using a spreadsheet program “NIST Color Quality Scale ver.9.0.1” available from NIST (Davis and Ohno 2010). The theoretical results are also put down with the experimental results in this session.

Figure 3 shows the comparison results of No. 20 light gray chip of the GretagMacbeth ColorChecker under six light sources. Each light source result was connected in ascending order. Under lower color temperature lighting conditions than 3000 K such as incandescent lamp (open circle dots in Figure 3), color reproduction of the smartphones display was not good, and the color tristimulus values were strange as compared with the values under higher color temperature lighting conditions. Most results of the GretagMacbeth ColorChecker indicated a similar tendency. Therefore, we used only the results under three light source higher color temperature than 5000 K in next discussions.

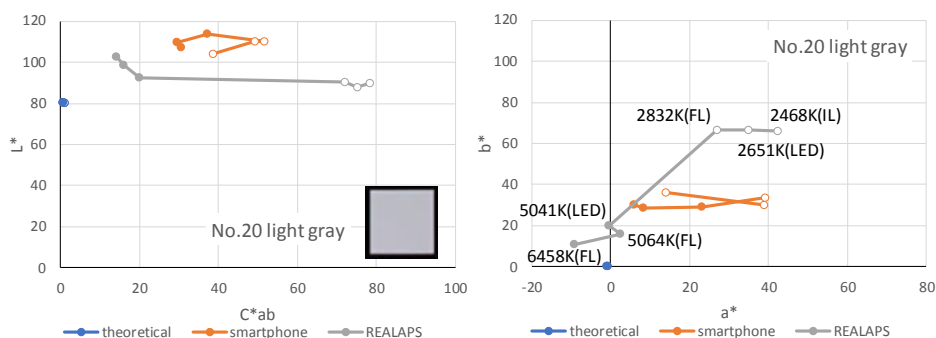

Figure 3: Comparison results of No. 20 of the GretagMacbeth ColorChecker under six light sources.

Figure 4 shows the comparison results of four higher chromatic chips of the GretagMacbeth ColorChecker under three light sources. Brightness ( $L^*$ ) and saturation ( $C^*ab$ ) on the smartphone display tended to express higher than the real  $L^*$  and  $C^*ab$ . Most results of the GretagMacbeth ColorChecker indicated a similar tendency, especially when the object colors were high-chroma.

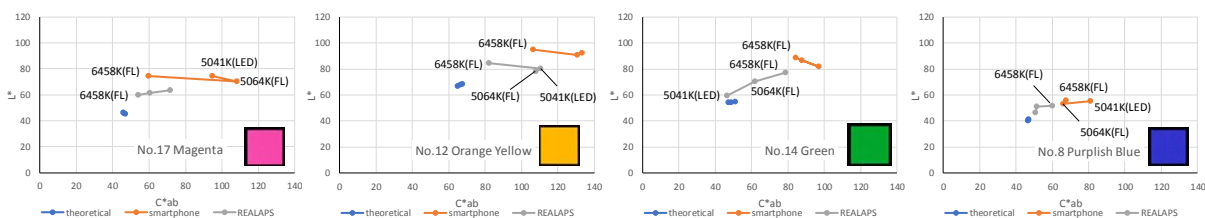

Figure 4: Comparison results of No. 17, 12, 14, 8 of the GretagMacbeth ColorChecker under six light sources.

Figure 5 shows the comparison results of decubitus photoprints under three light sources. Brightness ( $L^*$ ) and saturation ( $C^*ab$ ) on the smartphone display tended to express higher than the real  $L^*$  and  $C^*ab$  too. Therefore, the judgement of decubitus symptom by using smartphone’s images might be over evaluated and misconstrued.

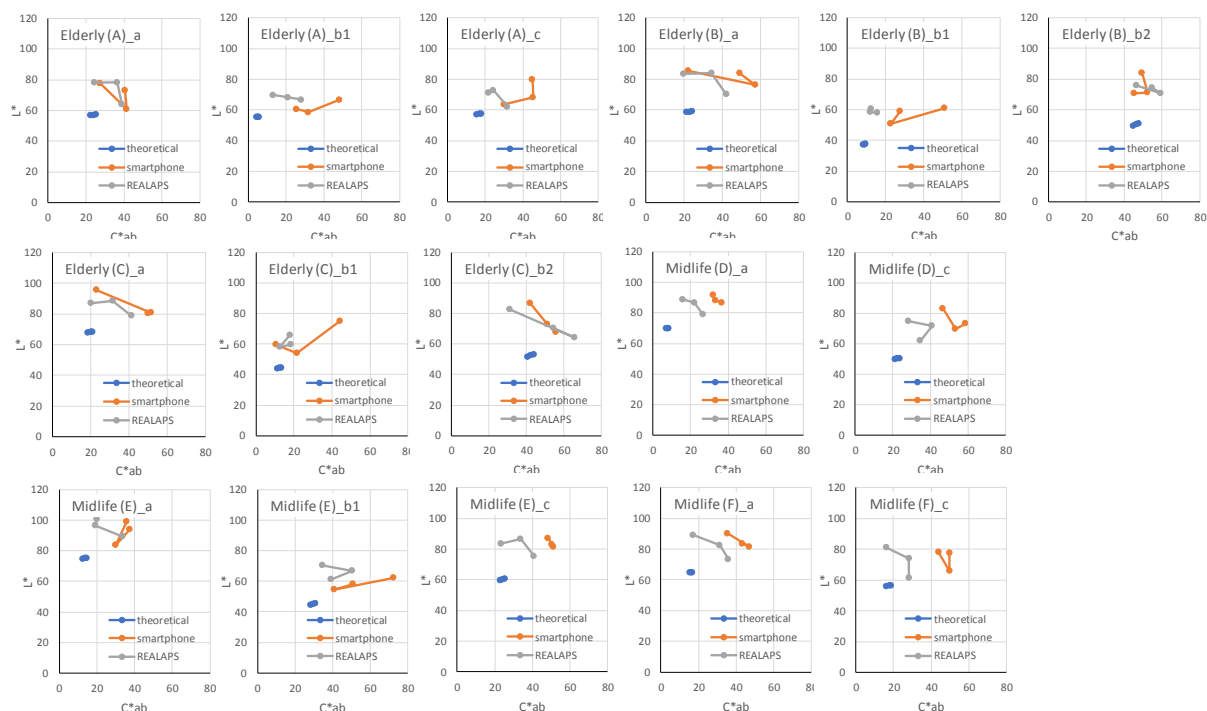

Figure 5: Comparison results of decubitus photoprints under six light sources.

## CONCLUSIONS

The wider color gamut, higher luminance and higher contrast by OLED smartphone displays can express attractive but excessive color representation like cinema film. And it should produce different color appearance from actual color. We must be more careful if we use smartphones in telemedicine treatment.

## ACKNOWLEDGEMENTS

This research was supported by JSPS KAKENHI Grant Number JP16K06607 and JP16H05570. The authors would like to thank Dr. Yoshi Ohno who let us to use “NIST Color Quality Scale (CQS) ver. 9.0.1”.

## REFERENCES

- Davis, W., and Y. Ohno. 2010. Color quality scale. *Optical Engineering* 49 (3), 033602.  
 Igaku Syuppan. 2016. The basis of decubitus care. *WOC Nursing* 4 (9).

# Comparison of colorimetric data from spectroradiometers and spectrophotometers

Chelsea Sullivan<sup>a\*</sup>, Stephen Westland<sup>a</sup>, Roger Ellwood<sup>b</sup>

<sup>a</sup> University of Leeds, UK

<sup>b</sup> Colgate-Palmolive Dental Health Unit, Manchester, UK

\* cp15crs@leeds.ac.uk

## ABSTRACT

This study evaluates how similar spectral data is from a spectrophotometer and a spectroradiometer. Both devices had similar measurement geometries: diffuse/8° for the spectrophotometer and diffuse/0° for the spectroradiometer with the VeriVide DigiEye lighting box. A total of 60 opaque pantone samples (i.e. 30 glossy and 30 matte) were measured. CIEDE2000 was calculated to determine the difference between the data from the two devices. Results showed that both devices produce similar CIELAB values with a mean colour difference of about 2. Both devices produced mean colour difference of about 8 between glossy and opaque samples. It is unclear how perceptible this colour difference value is.

**Keywords:** *colour measurement, spectral data, colour difference*

## INTRODUCTION

Colour is one of the most important attributes of appearance for many industries such as the fashion industry, dentistry, paints, food products, etc. Producing the 'correct' colour is critical. Established methods exist for measuring the colour of opaque, flat, and spatially uniform objects (Wyszecki and Stiles 2000). Devices such as spectrophotometers, spectroradiometers, and colorimeters are employed to take physical colour measurements. While spectrophotometers are generally considered the most 'accurate' method to measure the colour of opaque objects (Pan and Westland 2018), they are not always suitable for samples such as objects of a small size, non-planar objects, objects that are inaccessible (i.e. teeth *in vivo*), or small translucent materials. Although imaging spectrophotometers are now appearing on the market which can measure spectral data at every pixel and may help to provide a solution for some of these problems, their accuracy is untested in many circumstances.

Measuring the colour of teeth is particularly difficult due to their small size, non-planar shape, translucency, as well as being *in vivo*. One of the major issues for teeth is edge-loss, which is when

light is lost via the back or the sides and is not reflected back to the sensor, producing measurement errors. In dentistry, there is a debate about which is the best way to measure the colour of teeth to combat this edge-loss issue: spectrophotometers or spectroradiometers (Bolt et al. 1994, Joiner and Luo 2017). It is pertinent to understand how accurate the spectrophotometer and spectroradiometer diffuse/8° or 0° instruments are in their ability to measure colour with planar, opaque samples in order to gain understanding what is contributing to errors for unconventional materials. The point of this study is to investigate how similar spectral data is from spectrophotometers compared to spectroradiometers on both glossy and matte opaque samples.

## PROCEDURES

For comparison of spectral data, opaque samples were measured with a Konica Minolta CM-2600 handheld spectrophotometer as well as a Konica Minolta CS-2000 tele-spectroradiometer. The spectrophotometer has a diffuse/8° geometry with built in D65 lighting (Konica Minolta 2016). Spectroradiometers do not have a built-in light source so the use of ambient illumination is required. The spectroradiometer was used with a VeriVide DigiEye lighting box in order to achieve an approximated diffuse/0° geometry (Figure 1).



Figure 1: Spectroradiometer setup. On the left side is the outside of the spectrophotometer with the VeriVide DigiEye lighting box, and on the right is the inside of the setup to show the general diffuse/0° geometry of the device.

Spectrophotometers are capable of measuring both specular component included and excluded. The geometry used for the spectroradiometer with DigiEye lighting box explicitly excludes the specular component. Therefore, specular excluded data from the spectrophotometer was used for comparison. Both devices were calibrated for a 10° observer.

A set of 60 opaque samples (taken from the Pantone: The Plus series CMYK guide) were measured to compare the instruments. Pantone samples were chosen as they have become a standard for communicating colour (Burgett 2015). There are two different series: coated and uncoated. The Pantone uncoated set of samples were measured using a Konica Minolta CM-2600d spectrophotometer (2,868 total). An algorithm, developed in MATLAB, was used to randomly generate a selection of 30 pantone 'colours' from the 2,868 uncoated pantone samples. The algorithm selected 30 CIELAB values that were as different as possible from each other in colour space as shown in Figure 2 (Cheung and Westland 2006).



Figure 2: Thirty pantone randomly selected samples. These are the samples that were used in the study, it should be noted that they will not visually appear the same as in the study due to the medium in which they are presented.

A total selection of 60 samples were measured: 30 CMYK uncoated samples and 30 CMYK coated samples. process yellow, process magenta, and process cyan were 2.3 cm × 4.3 cm. The rest of the samples were 1.75 cm × 2.08 cm. To ensure the small apertures of the devices did not measure any white edges, the center of the sample was measured. Each sample was measured 3 times with a handheld spectrophotometer and with tele-spectroradiometer and the repeat measurements were averaged.

## DATA ANALYSIS

The spectrophotometer collected reflectance data for 360-740 nm at 10 nm intervals. The spectroradiometer collected radiance data from 380-780 nm at 1 nm intervals. Each sample was measured three times and these spectral data were averaged. The averaged data were truncated to 380-740 nm to ensure the measurements from the two instruments were comparable. Irradiance data from the spectroradiometer must be converted into reflectance data. The averaged irradiance spectral data was divided by an average spectral irradiance data of a standardized white and then multiplied by reflectance spectral data from a standardized white measured by a spectrophotometer (Zwinkels 1996). The spectrophotometer white data was interpolated in order to produce data at 1 nm intervals in order to convert the spectroradiometer data into reflectance data. Interpolation method was used in comparison to extrapolation as it is more accurate (Cheung and Westland 2006). In order to make colorimetric comparisons, averaged spectral data from each device for each sample was converted into CIELAB values.

The CIEDE2000 colour difference formula was used to quantify difference between the colorimetric data from the spectrophotometer and the spectroradiometer for the same samples. CIEDE2000 is considered the best formula for the assessment of small colour differences (i.e. under 5 units) (Wang et al. 2012, Luo et al. 2001).

## RESULTS & DISCUSSION

The average colour difference between the two instruments is relatively small (Table 1). This indicates that there is little difference between the two instruments when comparing the same samples and where, as in this case, the optical geometry between the two instruments has been matched. Note that whether the samples are glossy or matte has no effect on this finding.

Colour differences between glossy and matte samples are larger (Table 2). It is interesting to note that the mean colour difference values are similar for both devices indicating that they eliminate specular component to a similar extent.

$\Delta E_{00}$	Uncoated	Coated
Min	1.27	1.30
Max	4.15	3.73
Mean	2.11	2.09

Table 1: The max, min, and averaged CIEDE2000 colour difference values between spectrophotometer and spectroradiometer of uncoated and coated pantone samples.

$\Delta E_{00}$	Spectrophotometer	Spectroradiometer
Min	1.61	1.94
Max	15.56	14.59
Mean	8.24	8.15

Table 2: The min, max, and averaged CIEDE2000 colour difference values between the uncoated and coated samples when using the spectrophotometer and spectroradiometer.

Figures 3 and 4 show two examples out of 30, comparing the spectral data between spectrophotometers and spectroradiometers over 380-740 nm at 10 nm intervals. On the spectral level, there are differences between the two devices even after converting irradiance into reflectance. It is interesting to see how the spectral data changes with the glossy materials versus the uncoated. The matte samples in Figures 3 and 4 show little difference between the spectrophotometer and spectroradiometer. Greater difference can be seen for the glossy/coated samples, which could be due to how the light interacts with the glossy finish. When all 30 samples are considered, there is more difference in spectral data for certain colours than for other.

Li (2019) has reported errors of up to 18  $\Delta E$  can be found by changing the method of how the tristimulus values (i.e. CIEXYZ) are calculated (although this was for an F11 illuminant). There are also different methods for which  $\Delta E$  can be calculated provided a wide range of values (i.e. CIELAB, CIEDE2000, CIE94, CMC, CIELUV) (Wang et al. 2012). In industry there are two different colour difference thresholds: values that are perceptibly different as well as colour difference values that are considered acceptable. It is difficult, if not impossible, to put a single universal colour difference value for what will be perceptually different. The size of perceptibility and acceptability for colour difference could be completely different and will change based on the industry. Thresholds must be put into place to produce meaningful colour difference results.

This study only compared spectrophotometers and spectroradiometers with near-identical geometries, diffuse/8° and diffuse/0°. The mean colour difference results indicate that, for diffuse illumination geometries, either instrument can be used for the measurement of opaque samples. It should be noted the use of a VeriVide DigiEye illumination cabinet has shown to be a good way to produce diffuse/0° geometry for a spectroradiometer. The spectrophotometer had a geometry of diffuse/8°, while the spectroradiometer had a geometry of diffuse/0°. It could be that the colour differences shown in Table 1 could be smaller if the two geometries were identical instead of an 8° difference. While this instrumental geometry has produced small colour difference results, there are different measurement geometries such as a 45/0° which could produce more 'accurate' colour measurements. Comparison between diffuse/0-10° geometries and 45/0° should be investigated especially if changing the geometries could improve measurements for unconventional materials.

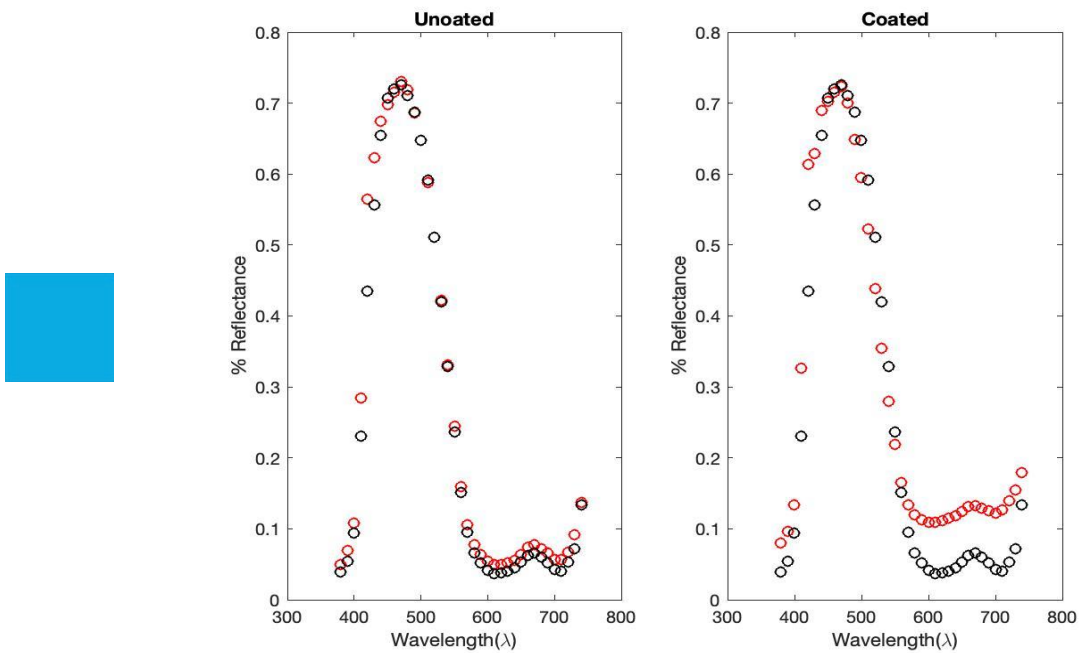

Figure 3: Spectroradiometer spectral data after conversion (red) compared to spectrophotometer spectral data (black) for process cyan pantone sample for wavelengths 380-740 at 10 nm intervals. The uncoated process cyan spectral data is on the left and coated process cyan spectral data on the right.

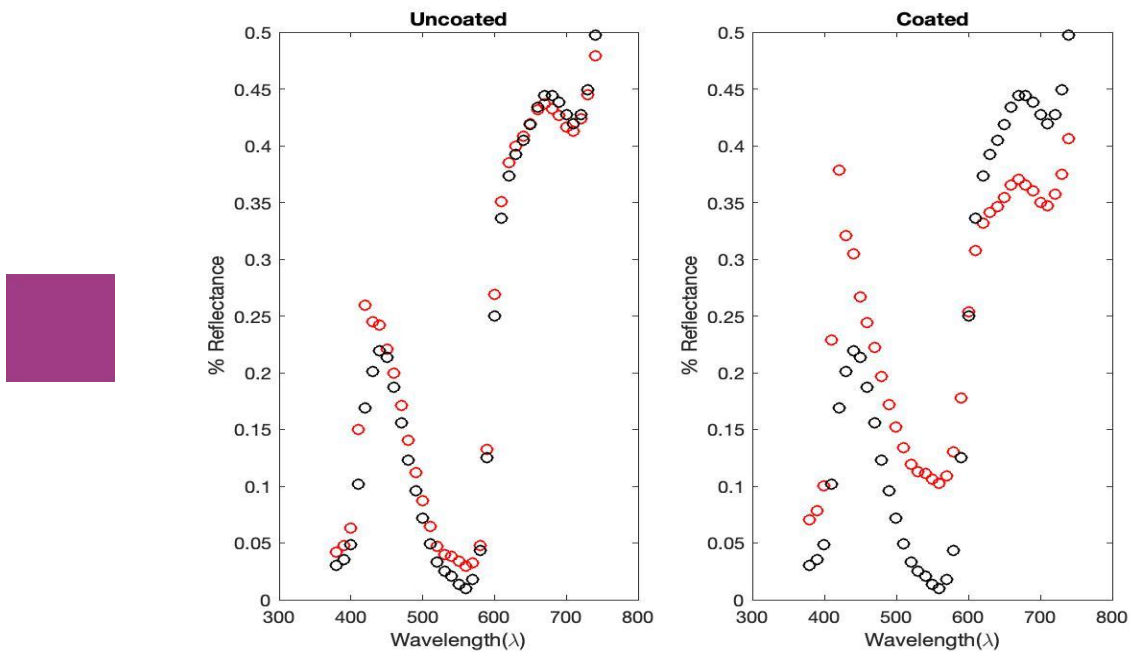

Figure 4: Spectroradiometer spectral data after conversion (red) compared to spectrophotometer spectral data (black) for 83.16 Pantone sample at wavelengths 380-740 at 10 nm intervals. The uncoated 83.16 pantone spectral data is on the left and the coated 83.16 samples spectral data the right.



The instrument devices used in this study were designed for the measurement of opaque samples. Opaque samples were used in this experiment, which could be the reason for such a small colour difference between spectrophotometers and spectroradiometers. However, unconventional materials (i.e. teeth, skin, food) could introduce further problems. Teeth specifically introduce many problems due to their attributes of being non-planar, small, and translucent.

Translucency introduces edge-loss, which is when light scatters through the material and is released out the back or the sides of the material and is not reflected back to the sensor of an instrument causing inaccurate colour measurement (Joiner et al. 2008, Bolt et al. 1994). For teeth, one study suggests there is less edge-loss when using spectroradiometers than with spectrophotometers due to difference in ratio between illumination and aperture/viewing size (Bolt et al. 1994). While in agreement with Bolt et al., others suggest that the cause of edge-loss is due to being contact based measurements (spectrophotometers) versus being a non-contact colour measurement system (spectrophotometers) (Joiner and Luo 2017).

Edge-loss is a major issue for physical measurements using instrumentation. By conducting this study, it has determined that spectrophotometer and spectroradiometers produce nearly similar results for each sample. This information can help with producing a solution for determining the best way to measure unconventional materials such as teeth.

## CONCLUSION

Gaining insight on the ability of spectrophotometers and spectroradiometers to ‘accurately’ measure opaque samples can help determine what is happening when measuring unconventional materials such as teeth. Based on the results from this study, there is a very small colour difference between the two devices. Either device can be used to measure the colour of opaque materials and produce colour results for both glossy or matte finishes. Larger colour difference values are produced when comparing matte samples to glossy samples, indicating that instruments can pick up the different finishes on the samples.

## ACKNOWLEDGEMENTS

We would like to thank Colgate-Palmolive for their generous sponsorship and support throughout our research journey.

## REFERENCES

- Bolt, R. A., J. J. Ten Bosch, and J. C. Coops. 1994. Influence of window size in small-window colour measurement, particularly of teeth. *Physics in Medicine and Biology* 39: 1133-1142.
- Burgett, S. 2015. Getting the best results with PANTONE colors. X-rite PANTONE, published June 22, 2015, [https://www.xrite.com/blog/best-results-pantone-colors?utm\\_source=google&utm\\_medium=cpc&utm\\_campaign=03-GO-NA-EN-DSA&utm\\_content=DSA\\_Website&utm\\_term=&matchtype=b&device=c](https://www.xrite.com/blog/best-results-pantone-colors?utm_source=google&utm_medium=cpc&utm_campaign=03-GO-NA-EN-DSA&utm_content=DSA_Website&utm_term=&matchtype=b&device=c).

- Cheung, V., and S. Westland. 2006. Methods for optimal color selection. *Journal of Imaging Science and Technology* 50 (5): 481-488.
- Joiner, A., I. Hopkinson, Y. Deng, and S. Westland. 2008. A review of tooth colour and whiteness. *Journal of Dentistry* 36s: S2-S7.
- Joiner, A., and W. Luo. 2017. Tooth colour and whiteness: a review. *Journal of Dentistry* 67: S3-S10.
- Konica Minolta. 2016. Spectrophotometer CM-2600d: simply expands the boundaries in color control. Konica Minolta Product Catalogue: 1-8. [https://www5.konicaminolta.eu/fileadmin/content/eu/Measuring\\_Instruments/2\\_Products/1\\_Colour\\_Measurement/2\\_Spectrophotometers\\_Portable/2\\_CM-2600d\\_CM-2500d/PDF/CM-2600d\\_EN.pdf](https://www5.konicaminolta.eu/fileadmin/content/eu/Measuring_Instruments/2_Products/1_Colour_Measurement/2_Spectrophotometers_Portable/2_CM-2600d_CM-2500d/PDF/CM-2600d_EN.pdf).
- Li, C. 2019. Methods for computing CIE tristimulus values. Lecture, Leeds, July 29th, 2019.
- Luo, M. R., G. Cui, and B. Rigg. 2001. The development of the CIE 2000 colour-difference formula: CIEDE2000. *Color Research and Application* 26 (5): 340-350.
- Pan, Q., and S. Westland. 2018. Tooth color and whitening – digital technologies. *Journal of Dentistry* 74: S42-S46.
- Wang, H., G. Cui, M. R. Luo, and H. Xu. 2012. Evaluation of colour-difference formulae for different colour-difference magnitudes. *Color Research and Application* 37 (5): 316-325.
- Wyszecki, G., and W. S. Stiles. 2000. *Color science: concepts and methods, quantitative data and formulae*, 2nd ed. New York: John Wiley & Sons.
- Zwinkels, J. C. 1996. Colour-measuring instruments and their calibration. *Displays* 16 (4): 163-171.

# Metamaterials: “Lenses” without chromatic aberration?

**Kazim Hilmi Or**

Private Office of Ophthalmology, Nisantasi, Istanbul, Turkey  
hilmi.or@gmail.com

## ABSTRACT

Metamaterials are artificially structured materials used to control and manipulate waves in physics and also in light. Some new metamaterials have unusual optical characteristics. One of these is to allow them to build new optical “lenses” (metamaterial in layers) which don’t have chromatic aberration, which may change the normal visual perception and accuracy of optical systems. Metamaterials like  $\text{TiO}_2$  (titanium dioxide) or graphene are used to make “lenses” (which are actually no lenses but layers of material or atoms) without any chromatic aberrations. These materials may help to have very sharp optical systems and no or very little colour aberrations in optical systems. These may change the image and the colour perception in everyday life, science, photography and imaging.

**Keywords:** *metamaterials, lenses, no chromatic aberration, colour perception*

## INTRODUCTION: METAMATERIALS. OPTICS AND COLORS

Metamaterials do not exist in nature. They are artificially structured materials. They can change or manipulate waves in physics. Light is due quantum theory particle and wave at the same time. So light waves can be manipulated by metamaterials, also.

Conventional optical lenses have optical properties which are due to the nature of normal light wave propagation in transparent media. In any optical system and in each of optical lenses there are eight different optical aberrations. No one of them can be reduced to zero. If one tries to lower one of them one or more other aberrations are increased. Chromatic aberration is one of them (Baer et al. 2016, Forrester et al. 2016).

Optical drawing of images and resulting visual perception in the brain may be different (Or 2007). Same colors may perceived by clinically color normal people as different colors (Or 2017). Chromatic aberration is different from this.

### CHROMATIC ABERRATION IN CONVENTIONAL OPTICAL LENSES

White light (which is a mixture of light rays with wavelengths between 400-800 nm) or other lights with mixed wavelength composition are refracted in optical media and lenses, so that the rays with different wavelengths are refracted differently. That results in that all light rays with different wavelengths (with different colours) are focused in different distances. The end result is, that after refracted in an optical lens a white (perceived) point formed light ray is focused in different distances. So an image focused in white light gets chromatically aberrated after refracted through an optical lens (Figure 1).

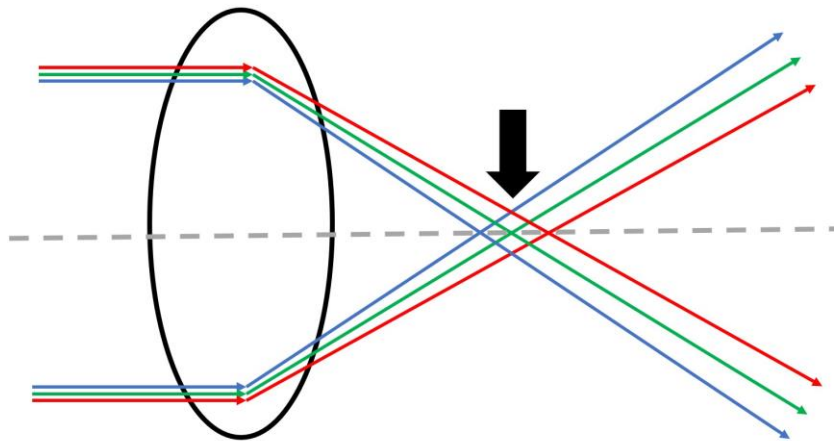

Figure 1: Chromatic aberration in conventional lenses.

### NO CHROMATIC ABERRATION IN METAMATERIAL OPTICAL SYSTEMS (LENSES)

Graphene and similar metamaterials are just one atom thick. Because they are so thin, they are called 2 D (two dimensional) materials, although they are 3 D (three dimensional) (Figure 2).

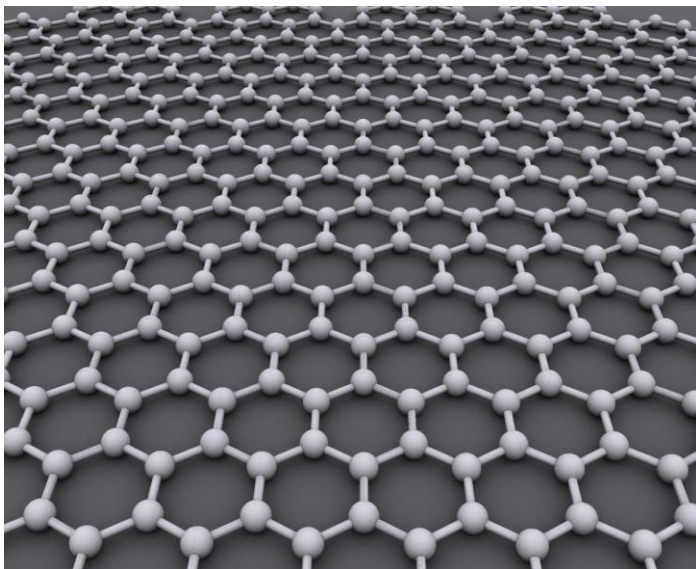

Figure 2: Example for metamaterial: Graphene. Source: <https://en.wikipedia.org/wiki/Graphene>.

Graphene can refract the white light without producing chromatic aberration. So one can have sharper and better quality images after the refraction (Yang et al. 2018).

Graphene based lenses refract to sharper edged images (Figure 3). They have also at the colour area transitions no wrong colored areas which may happen in conventional lenses (Lalanne and Chavel 2017, Ooi and Tan 2017) (Figure 4).

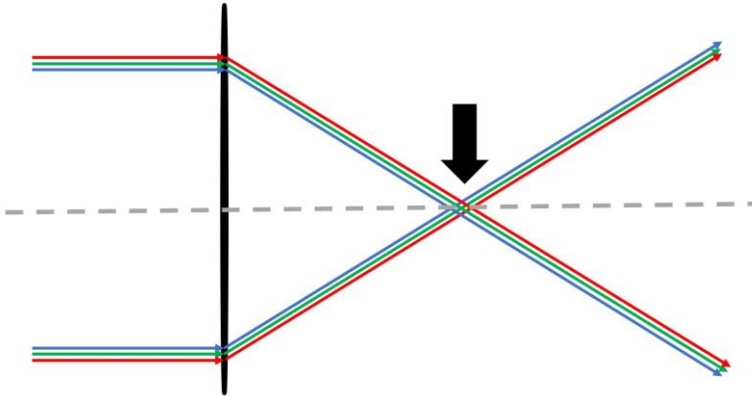

Figure 3: Graphene based flat lenses may have almost no chromatical aberration.



Figure 4: An example withouth chromatic aberration (above) and with chromatic aberration (below).

Source: [https://de.wikipedia.org/wiki/Chromatische\\_Aberration](https://de.wikipedia.org/wiki/Chromatische_Aberration).

## CONCLUSION

With metamaterial lenses there may be very sharp images without or very little chromatic aberration. So colors in refracted images are right at the transition areas. This property enhances also the sharpness of the image.

## REFERENCES

- Baer, R., M. Barfuss, and D. Seifert. 2016. *Beleuchtungstechnik. Grundlagen*, 4th ed. Berlin. Huss-Medien.
- Forrester, J. V., A. D. Dick, P. G. McMenemy, F. Roberts, and E. Pearlman. 2016. *The eye. Basic sciences in practice*, 4th ed. Edinburgh: Saunders & Elsevier.
- Lalanne, P., and P. Chavel. 2017. Metalenses at visible wavelengths: past, present, perspectives. *Laser & Photonics Reviews* 11 (3): 1600295.
- Ooi, K. J. A., and D. T. H. Tan. 2017. Nonlinear graphene plasmonics. *Proceedings: Mathematical, Physical and Engineering Sciences* 473 (2206): 20170433.
- Or, K. H. 2007. *The difference of light drawing in vision and photographic art*. Istanbul: Marmara University, Institut of Fine Arts, master thesis.
- . 2017. *The object colour perception of colour vision normal eye witnesses under artificial light sources*. Istanbul: Forensic Medicine Institute of Istanbul University, PhD thesis.
- Yang, G., L. Li, W. B. Lee, and M. C. Ng. 2018. Structure of graphene and its disorders: a review. *Science and Technology of Advanced Materials* 19 (1): 613-648.

# What is the goal of the wine chromatic characterization in a CIE color space?

Andrés Martín<sup>abe\*</sup>, Bárbara Silva<sup>ae</sup>, Cecilia M. Lasagno<sup>c</sup>, Víctor Novello<sup>d</sup>, Sergio Gor<sup>ae</sup>

<sup>a</sup> Instituto de Investigación en Luz, Ambiente y Visión (ILAV), Universidad Nacional de Tucumán (UNT)

Consejo Nacional de Investigaciones Científicas y Técnicas (CONICET), Tucumán, Argentina

<sup>b</sup> Universidad Tecnológica Nacional (UTN), FRT, Tucumán, Argentina

<sup>c</sup> INAHE-CONICET, Mendoza, Argentina

<sup>d</sup> Viña Las Perdices SA, Mendoza, Argentina

<sup>e</sup> Universidad Nacional de Tucumán (UNT), Tucumán, Argentina

\* amartin@herrera.unt.edu.ar

## ABSTRACT

There is a vast amount of specialized literature about color, and on the other hand, a vast amount of specialized literature about how to characterize wine color. The proposed methods to assess wine color were evolved: from Sudraud in the late 1950s through Glories in the mid-1980s to the nowadays CIE tristimulus based values. This evolution rises the question about the objective of a chromatic characterization of wines which in turn challenges the supposed advantages of evaluating the color of wine through a CIE color space. We present a bibliographic review in order to analyze the ideas behind wine color characterization. One finding of this review is the fact that wine color becomes an ambiguous concept that oscillates between a naive definition of color and a chemical one.

**Keywords:** wine color, CIE color space, color characterization

## INTRODUCTION AND THEORY

Although color is one of wine's most outstanding characteristics, it could be said that the idea of a precise, and useful, wine color characterization begins when chemical knowledge reaches a level that allows us to explain "color" from the composition of the wine, particularly on the basis of phenolic compounds. That is the reason why Sudraud (1958) measured optical absorbancies at 420 and 520 nm to characterize "hue" and "color density" in order to quickly obtain some relevant information about wine age and condition; of course, such information comes from the fact that the phenolic composition interacts optimally with light at these wavelengths. The same logic was followed by Glories (1984) when incorporates a new wavelength (620 nm) to quantify "color intensity", a modification to Sudraud's method with the objective of enhance the weight of "red". Both Sudraud and Glories, followed the same reasoning: compositional aspects of the wine (e.g. phenolics, tannins

and anthocyanins combinations) determinate wine color and these (chemical) compositional aspects can be estimated by measuring absorbancies at the specified wavelengths.

On the grounds of they work, the following formulas were obtained:

“Color” intensity (CI)	=	$A_{420} + A_{520} + A_{620}$
Hue (Tone)	=	$A_{420} / A_{520}$
Proportion of Blue	=	$100 * A_{420} / CI$
Proportion of Yellow	=	$100 * A_{520} / CI$
Proportion of Red (dA%)	=	$100 * (A_{520} - \frac{1}{2} * (A_{420} + A_{620})) * 1/A_{520}$

Table 1: “Color” indicators derived from Sudraud and Glories. All A values are absorbancies. All numbers in subscript are wavelengths.

A word on the measurement procedures must be said to complete the picture of the information that is encoded by these indicators. Using a spectrophotometer records are taken of the absorbance at 420, 520 and 620 nm with the sample in a cell of certain width (path length), typically 1, 2, 5 or 10 mm. Thus, absorbancies depends upon cell width and therefore absolute quantities (e.g. “color” intensity) will also varies accordingly. In order to compare two “color” intensities we must first ensure that the numbers were obtained from the same cell width. It is a common practice to refer all absorbancies to a cell width of 10 mm (Somers and Evans 1977).

The formulas cited above become usual in wineries and a standard for winemakers. The Office Internationale de la Vigne et du Vin (OIV) adopted these indicators in 1962 and in 1990. However, at the same time, the OIV had also recommended to follow a simplified CIE tristimulus, based method to characterize wine color (a more detailed story in Martínez et al. 2001; for a detailed review about the relationship between chemical wine compounds and color: Boulton 2001. A good starting point about the ideas of the relationship between chemical compounds and the effect on perceived color is Gonnet 1998). At this point, it is interesting to ask why (and what for) the OIV recommend both methods simultaneously.

Conceptually the Sudraud and Glories formulas, from a visual point of view, do not encode any color information at all (which explains our use of the quoted word “color” to refer to its terms). These formulas assume that the color belongs to the object itself and, consequently, avoids a description of the three “basic” color attributes: hue, saturation and lightness; it also reduces color to a physical phenomenon and does not take it as a psychophysical one, which involves a light source, an object and an observer. On the other hand, the CIE tristimulus method, does encode color information as a psychophysical phenomenon and, in principle allows us to derive the three basic color attributes. In fact, the XYZ values refers to a “metameric state” of the visual system: the same visual stimulation will be achieved by adjusting the XYZ primaries in those particular values onto a white reflective surface. Of course, assuming the observer is at the same (white light) adaptation state. Thus, it seems to refers to the wine’s color “as seen in the glass”.

This idea that wine color information is better coded by the CIE indicators led some researchers to look for a possible linear transformation of the absorbencies (used to calculate chemical color indicators) into XYZ primary values. Some studies have shown very good agreement between the



numbers obtained with the “primaries” of Sudraud-Glories method and their respective XYZ or Lab values (Monagas et al. 2006, Pérez-Magariño and González-Sanjosé 2003; see Table 2). However, the lack of a good correlation between instrumentally estimated values and visual evaluations of consumers and winemakers cast doubt on the benefits of this color characterization (Little 1980). While it is true that CIE indicators can be interpreted more easily with respect to color perception, the results do not show the expected best correlation with perceptual evaluations.

The above problems led, on the one hand, to seek alternative methodologies to characterize the color of the wine and on the other to indicate the limits of current methodologies (Martin et al. 2007, Pridmore 1999, 2005).

CIE primary	Formula
X	$= 0.42 * A_{625} + 0.35 * A_{550} + 0.21 * A_{445}$
Y	$= 0.20 * A_{625} + 0.63 * A_{550} + 0.17 * A_{495}$
Z	$= 0.24 * A_{495} + 0.94 * A_{445}$

Table 2: Linear transformation from absorbancies to XYZ primaries. Formulas from the OIV. All A values are absorbancies. All numbers in subscript are wavelengths.

## DISCUSSION

The logical path that has been followed, has combined a mixture of knowledge and technology that was at hand. Not wonder that has begun by the correlation between the chemical characteristics and those elements of the wine that determine its coloration: in the winemaking process, the chemical control of these variables is key, since otherwise the entire product can be ruined. On the opposite end, once the product has been prepared, winemakers embark on the competition for the conquest of the consumer, for which it is essential to achieve a specific color (Hutchings 2002). However, it is not so simple the relationship between the chemical variables that underlie the color of the wine and the color perceived by consumers or specialists. On the contrary, wine, from a visual point of view, is extremely complex: it is a translucent liquid substance, with different amounts of elements suspended in it and that can be seen in containers of variable geometry which results in different thicknesses of the beverage; in addition, lighting conditions can vary greatly. All this explains in some way the reasons why good correlations with color systems have not yet found. Its reduction to, generally, three variables, results in a too simplified version that does not succeed capture the most relevant keys related to the color of the wine.

This has resulted in the characterization appeals to a “chemical” color to indicate specific characteristics and a trichromatic color to indicate others. In this sense, while chemical characterization is based on a long tradition and proven utility, the reduction to a CIE color space does not end, from our point of view, of justifying their employment. This lack of justification lies above all in that the use of a CIE color space does not meet expectations about the usefulness of having such a characterization.

## CONCLUSION

In conclusion, we can say that the characterization of the color of the wine through a CIE color space does not reach the objective of summarizing, in a few indicators, the most relevant information about the color of the wine “as seen in the glass”. We think that it is necessary to think about what color appearance models propose, models that are still in development. In this regard, the wine complexity should be incorporated, developing and specifying the concepts that are considered as key. Some of them could be those that are already encoded in the vocabulary of color appearance.

A separate condition that should be verified, it would be the correlation between the indicators that characterize the color and the chemical characteristics that underlie this color.

## REFERENCES

- Boulton, R. 2001. The copigmentation of anthocyanins and its role in the color of red wine: A critical review. *American Journal of Enology and Viticulture* 52 (2): 67-87.
- Glories, Y. 1984. The colour of red wines. Part 2. Measurement, origin and interpretation. *Connaissance de La Vigne et Du Vin* (France).
- Gonnet, J.-F. 1998. Colour effects of co-pigmentation of anthocyanins revisited—1. A colorimetric definition using the CIELAB scale. *Food Chemistry* 63 (3): 409-415.
- Hutchings, J. 2002. The perception and sensory assessment of colour. In: *Colour in food: Improving quality*, D. B. MacDougall, ed. Cambridge, UK: Woodhead Publishing.
- Little, A. C. 1980. Colorimetry of wines. *Color Research and Application* 5 (1): 51-56.
- Martin, M. L. G.-M., W. Ji, R. Luo, J. Hutchings, and F. J. Heredia. 2007. Measuring colour appearance of red wines. *Food Quality and Preference* 18 (6): 862-871.
- Martínez, J. A., M. Melgosa, M. M. Pérez, E. Hita, and A. I. Negueruela. 2001. Note. Visual and instrumental color evaluation in red wines. *Food Science and Technology International* 7 (5): 439-444.
- Monagas, M., P. J. Martín-Álvarez, B. Bartolomé, and C. Gómez-Cordovés. 2006. Statistical interpretation of the color parameters of red wines in function of their phenolic composition during aging in bottle. *European Food Research and Technology* 222 (5): 702-709.
- OIV (Office Internationale de la Vigne et du Vin). 1990. *Recueil des méthodes internationales d'analyse des vins*. Paris: OIV.
- Pérez-Magariño, S., and M. L. González-Sanjosé. 2003. Application of absorbance values used in wineries for estimating CIELAB parameters in red wines. *Food Chemistry* 81 (2): 301-306.
- Pridmore, R. W. 1999. Bezold-Brucke hue-shift as functions of luminance level, luminance ratio, interstimulus interval and adapting white for aperture and object colors. *Vision Research* 39 (23): 3873-3891.
- . 2005. Color variability of wine in a glass and general comments on contrast effects. *Color Research and Application* 30 (2): 146-149.
- Somers, T. C., and M. E. Evans. 1977. Spectral evaluation of young red wines: Anthocyanin equilibria, total phenolics, free and molecular SO<sub>2</sub>, “chemical age”. *Journal of the Science of Food and Agriculture* 28 (3): 279-287.
- Sudraud, P. 1958. Interpretation des courbes d'absorption des vin rouges. *Annales de Technologie Agricole* 7 (2): 203-208.

# Prevention of the color changes in waterborne antimicrobial coatings with nano-functionalized siliceous filler

Leyanet Barberia-Roque<sup>a\*</sup>, Erasmo Gámez Espinosa<sup>a</sup>, Marisa Viera<sup>ab</sup>, Natalia Bellotti<sup>ac</sup>

<sup>a</sup> Centro de Investigación y Desarrollo en Tecnología de Pinturas, CIDEPINT (CICPBA, CONICET, UNLP), Argentina

<sup>b</sup> Facultad de Ciencias Exactas, Universidad Nacional de la Plata, Argentina

<sup>c</sup> Facultad de Ciencias Naturales y Museo, Universidad Nacional de La Plata, Argentina

\* l.barberia@ing.unlp.cidepint.edu.ar

## ABSTRACT

Color fastness represents the capacity of a given paint to maintain its original color over the time when exposed to biotic and abiotic environmental factors. The aim of this work is to assess the color changes due to the addition of Ag nanoparticles in a natural siliceous based material in coatings. Analysis of the color data from 24 hours showed the effectiveness of the functionalized materials to decrease the color change. Paints with nanoparticles added directly presented color variation rated as very big, considering the colorimeter method by Teichmann, while with the addition of functionalized silica was barely evident. These results kept during the six months in which the study was conducted.

**Keywords:** *silver nanoparticles nano-functionalized, color change, antimicrobial waterborne paint*

## INTRODUCTION

In the decorative paints field, color fastness represents the capacity of a given paint to maintain its original color over the time when exposed to environmental conditions such as chemical attack, UV radiation and the organisms activities (Hare 1992). The color of coatings is generated by addition of pigments, which can selectively absorb light in the visible spectrum. Waterborne coatings are colloidal systems composed of mineral and organic particles of distinctive sizes and shapes, dispersed at different volume concentrations into a polymeric resin. They also include small quantities of specific chemical species, additives whose function is to enhance the paint properties such as foam control, flow, leveling and rheology (Mahltig 2017).

In environmental engineering, biodeterioration is defined as any detrimental change made by an organism on a surface (Morton and Surman 1994). These changes can be caused by the mere presence of the organism as well as the result of its metabolic activity and can affect both the appearance and the structure of the materials, as well as potentially damaging to human health. The potential of metals to inhibit the growth of bacteria and fungi is well known, the mechanistic

background of metallic antimicrobial effects is still under discussion and not yet fully understood (Mahltig 2017).

In recent years, the use of metal nanoparticles has been intensely studied as a antimicrobial component to be applied in functional material (Saratale et al. 2018). Despite all the advantages of adding metal compounds to paints, some of their properties are affected given the reactivity of metal ions (Arreche et al. 2015). For this reason, the addition of functionalized components with nanoparticles in coating formulations is an increasingly contemplated option (Barberia-Roque et al. 2019). However, some characteristics of the coating are affected by the nanoparticles, the color is one of the most recurrent (Zheng et al. 2018).

Silver nanoparticles have been used for the functionalization of other materials, transferring their antimicrobial activity to them and decreasing incidence on the color (Arreche et al. 2019). In the present research a natural siliceous based material-functionalized with silver nanoparticles has been used as an antimicrobial additive for a paint formulation. The color changes and antimicrobial performance during six months of natural aging were measured.

## MATERIALS AND METHODS

### Obtaining of nano-functionalized siliceous filler

A powdered siliceous material (SM), extract from Río Negro, Argentina; was first activated with an alkaline solution of NaOH 2.2 M (Fernández and Bellotti 2017). Then, two strategies were used: the direct addition of AgNO<sub>3</sub> 10<sup>-2</sup>M solution (SMAg) and the addition of silver complexed with ammonium (SMAgC). Seven grams of activated SM was mixed with 100mL of the salt solution. The amount of adsorbed silver in the SM was determined from measurements of silver in the supernatant by a Mohr method variation.

Silver ions were reduced using the aqueous plant extract of *Senna occidentalis*, following a green synthesis method (Barberia-Roque et al. 2019). The green synthesis of free nanoparticles (AgNps) was carried out using the same silver nitrate solution and the plant extract as a reducing agent.

### Paint preparation

The base paint composition was (% by mass): 48.6% of distilled water, 25.9% CaCO<sub>3</sub> (natural), 6.3% acrylic resin (1:1), 3.6% TiO<sub>2</sub>, 2.0% CaCO<sub>3</sub> (precipitated) and 3.6% of additives (antifoaming, cellulosic thickener, dispersants and surfactants). The three products (AgNPS, SMAg and SMAgC) previously obtained were incorporated into the waterborne acrylic paint considering a silver concentration of 25 mg / 100 g of total paint.

Three different paintings were obtained AgNPsP, SMAgP and SMAgCP, respectively. In addition, two control paints without biocides were used: the base paint formulation (CP) and the base paint formulation with SM (SMP). The paints were applied on glass slides and cured for fifteen days. Some glasses were aged for six months exposed to natural light from behind a window, in laboratory conditions.

### Color measurement

Color was measured by the CIELAB system with a colorimeter By K Gardner. CIELAB gloss and color parameters were evaluated on cured paints during their sunlight exposure. The change of color ( $\Delta E$ )

was calculated as:  $\Delta E = [(a - a_0)^2 + (b - b_0)^2 + (L^* - L_0^*)^2]^{1/2}$ , being: “a” the variation between magenta blue and green, “b” the variation between yellow and green and “L\*” into black and white. The CIELAB parameters at  $t = 0$  are referred as:  $a_0$ ,  $b_0$ , and  $L_0^*$  while  $a$ ,  $b$  and  $L^*$ , correspond with the time elapsed. Visual appearance and  $\Delta E$  were related with the rating as follow:  $< 0.2$  No visible,  $0.2-0.5$  Very slightly,  $0.5-1.5$  Slightly,  $1.5-3.0$  Evident,  $3.0-6.0$  Very evident,  $6.0-12.0$  Big,  $> 12.0$  Very big (Arreche et al. 2019). An ANOVA parametric method was performed using the Tukey test for media comparison with 95% of confidence. SigmaPlot software was used in tabulation and graphing of all data.

### Normalized antimicrobial assay

The antifungal efficiency of the prepared paints was evaluated by an in vitro procedure similar at the ASTM D5590 specification. The painted glasses, after two weeks and six months of aging, were cut in  $2.5 \times 2.5$  cm and placed in minimum mineral media. The samples were inoculated with 50  $\mu$ L of a spore suspension ( $10^5$  spores/mL) of *Chaetomium globosum* KU 936228. The suspension was distributed homogeneously all over the painted surface. After four weeks of incubation at 28°C, fungal growth on the painted glasses was evaluated using a Leica magnifying glass at with an increase of 40 x.

## RESULTS AND DISCUSSION

### Color change

The color assessment of the samples showed that, AgNPsP had the greatest change respect to the control whose initial values were used as a standard throughout the experiment like  $a_0$ ,  $b_0$  and  $L_0^*$ . Statistical analysis of the color data from 24 hours showed the effectiveness of the functionalized materials to decrease the color change, as it can be seen in Figure 1. However, in all paints containing nanoparticles,  $\Delta E$  changes were statistically significant, which translates to naked eye detectable color changes. No significant differences were observed between  $\Delta E_{30}$  and  $\Delta E_{180}$  (subscripts represent aging time), in all the paints.

The color variation in the control paints was rated as slight. In the alternative paints with SMAg and AgNps it was big and very big. However, with the addition of SMAgC, the color change was barely evident. The color variation over time highlighted the effectiveness of the SMAgC to prevent the color change by approximately six months of weathering. These results allowed determining that the functionalization of SM with AgNPs is not enough the color change. However, we could conclude that complexing silver with ammonium helps to preserve more efficiently the properties of the paints.

The parameter  $L^*$  had a higher incidence on the color change measured in each of the paintings. This phenomenon could be due to can be attributed to the composition initially and decomposition later of black compounds as those formed when silver reacts with sulfur compounds at the environmental pollution. Degradation of these compounds by the action of light or  $O_3$  could explain that  $L^*$  was the most affected color parameter during the natural aging process (Arreche et al. 2019). There were no significant changes in the brightness of the paints obtained with respect to the CP even after the aging process. The overall average brightness was 2 approximately.

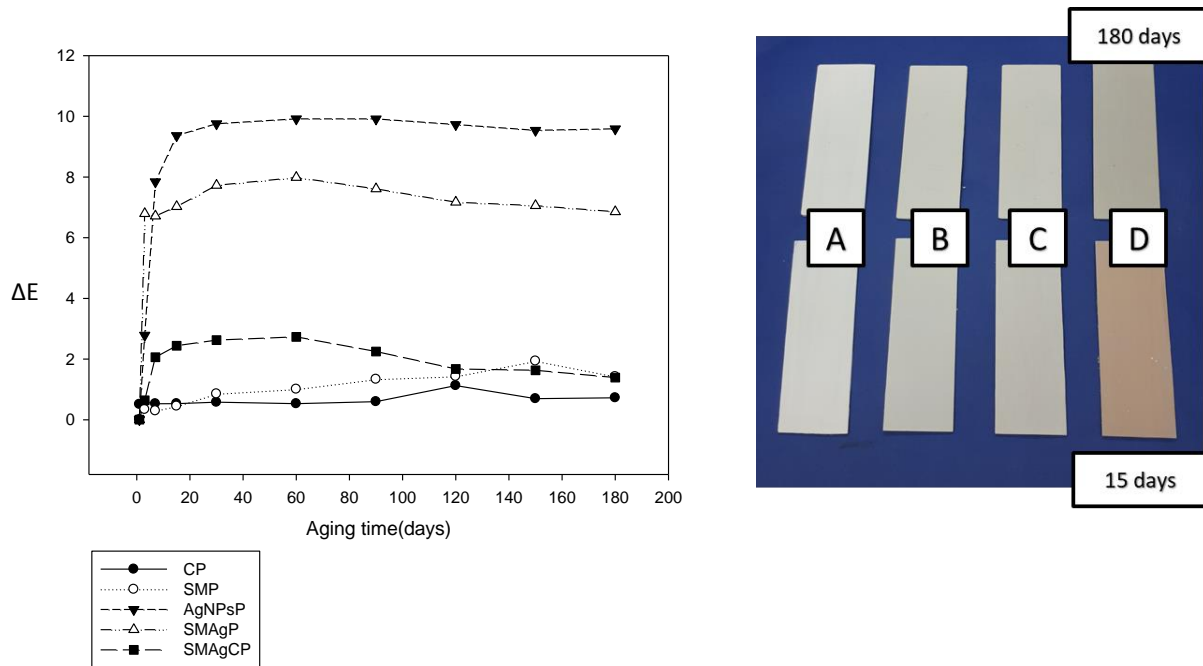

Figure 1: Graph of color change over time for six months (left). Paintings after 15 and 120 days of curing (right) (A: CP; B: SMAgCP; C: SMAgP and D: AgNpsP).

### Antifungal activity

All paints with AgNps showed a high degree of antifungal activity which can be seen in Figure 2. Control paint CP in Figure 2A, shows the development of the inoculated spores. In the rest of the samples (Figure 2B, C, D) can be observed how the inoculated spores were not even able to germinate. All the samples were rated as 0 according to the ASTM. However, samples with the functionalized fillers at  $t = 0$  and those aged showed fungal growth around them while the paints without SM only presented fungal growth around the samples after six months, which could be related to loss of antifungal activity over time.

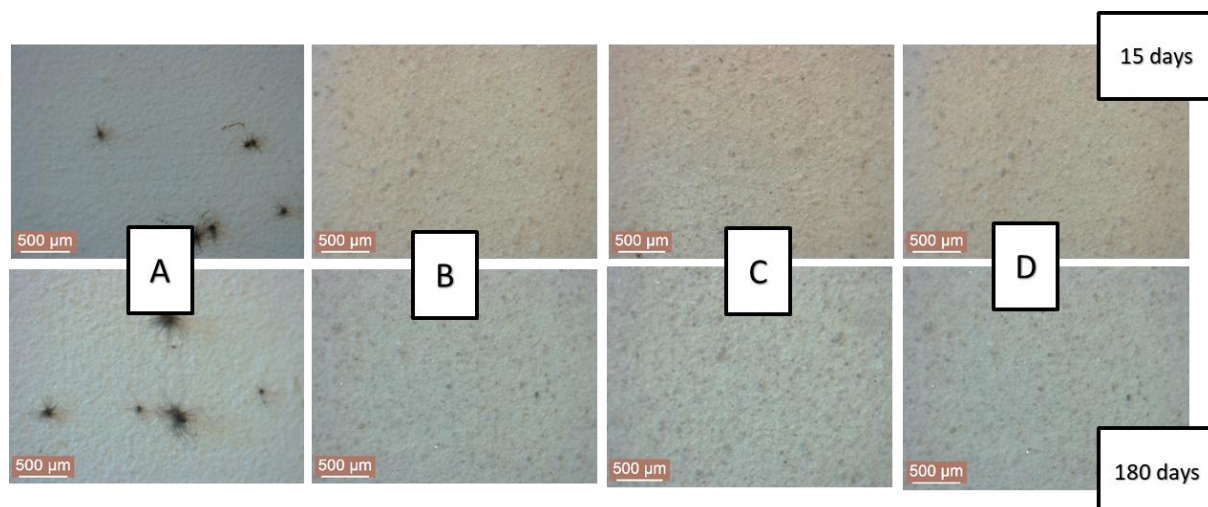

Figure 2: Antifungal assay against *C. globosum* (A: CP; B: SMAgCP; C: SMAgP and D: AgNpsP).

## CONCLUSIONS

In the present work we have found that the functionalization of SM with silver nanoparticles impart their antimicrobial activity to the coatings, therefore, functionalized SM can be used as biocide in waterborne coating formulations. The addition of nanoparticles, associated to SM positively affects the maintenance of the color of the tested waterborne paint, allowing the color to remain without significant alterations over time.

## ACKNOWLEDGEMENTS

The authors thank CICPBA, UNLP and CONICET for the financial support.

## REFERENCES

- Arreche, R., K. Igal, N. Bellotti, and P. Vázquez. 2015. Microbiological prevention using functionalized materials as ecological additives in hygienic paints. *Procedia Materials Science*. <https://doi.org/10.1016/j.mspro.2015.05.040>.
- Arreche, R., K. Igal, N. Bellotti, C. Deyá, and P. Vázquez. 2019. Functionalized zirconia compounds as antifungal additives for hygienic waterborne coatings. *Progress in Organic Coatings*. <https://doi.org/10.1016/j.porgcoat.2018.12.004>.
- Barberia-Roque, L., E. Gámez-Espinosa, M. Viera, and N. Bellotti. 2019. Assessment of three plant extracts to obtain silver nanoparticles as alternative additives to control biodeterioration of coatings. *International Biodeterioration and Biodegradation*. <https://doi.org/10.1016/j.ibiod.2018.06.011>.
- Fernández, M. A., and N. Bellotti. 2017. Silica-based bioactive solids obtained from modified diatomaceous earth to be used as antimicrobial filler material. *Materials Letters*. <https://doi.org/10.1016/j.matlet.2017.01.144>.
- Hare, C. H. 1992. The degradation of coatings by ultraviolet light and electromagnetic radiation. *Journal of Protective Coating & Linings*, May: 8029-8032.
- Mahltig, B. 2017. Metal pigments as antimicrobial agent and coating additives. In: *Handbook of Antimicrobial Coatings*. Elsevier, 283-299. <https://doi.org/10.1016/b978-0-12-811982-2.00014-7>.
- Morton, L. H. G., and S. B. Surman. 1994. Biofilms in biodeterioration - a review. *International Biodeterioration and Biodegradation*. [https://doi.org/10.1016/0964-8305\(94\)90083-3](https://doi.org/10.1016/0964-8305(94)90083-3).
- Saratale, R. G., I. Karuppusamy, G. D. Saratale, A. Pugazhendhi, G. Kumar, Y. Park, G. S. Ghodake, R. N. Bharagava, J. R. Banu, H. S. Shin. 2018. A comprehensive review on green nanomaterials using biological systems: Recent perception and their future applications. *Colloids and Surfaces B: Biointerfaces*. <https://doi.org/10.1016/j.colsurfb.2018.05.045>.
- Zheng, K., M. Setyawati, D. Leong, and J. Xie. 2018. Antimicrobial silver nanomaterials. *Coordination Chemistry Reviews*. <https://doi.org/10.1016/j.ccr.2017.11.019>.

# Common patterns of color change related to sex, season and latitude in small mammals museum specimens

María Leonor Sandoval Salinas<sup>ab\*</sup>, José D. Sandoval<sup>ac</sup>,  
Elisa M. Colombo<sup>ac</sup>, Rubén M. Barquez<sup>b</sup>

<sup>a</sup> Instituto de Investigación en Luz, Ambiente y Visión (ILAV), Universidad Nacional de Tucumán (UNT), Consejo Nacional de Investigaciones Científicas y Técnicas (CONICET), Argentina

<sup>b</sup> Programa de Investigaciones de Biodiversidad Argentina (PIDBA), Facultad de Ciencias Naturales e Instituto Miguel Lillo, UNT, Argentina

<sup>c</sup> Departamento de Luminotecnia, Luz y Visión (DLLyV), Facultad de Ciencias Exactas y Tecnología, UNT, Argentina

\* maritizandoval@yahoo.com.ar

## ABSTRACT

Our main goal was to analyze objectively measured color data from a taxonomically wide sample, to identify, if any, common patterns of color changes in several species of small rodents. The sample included 393 specimens housed in two mammals collections: 300 in The Field Museum (Chicago, USA), whose pelage color were measured pelage color with an Ocean Optics USB2000+, and 93 in the Smithsonian National Museum of Natural History (Washington, DC, USA), measured with an X-Rite eXact spectrophotometer. We used the R package “pavo” for spectral data, and principal component analysis and general linear models of analysis of variance for CIELAB data. We found a number of relationships and associations between individual pelage color variation and sex, season, latitude, longitude, altitude, and sample antiquity, which are common to a number of species specimens. Although the situation is complex and deserves to be analyzed with care, some interesting common patterns emerge.

**Keywords:** *biology, colorimetry, natural history museums, natural sciences, pelage color*

## INTRODUCTION

Collections in Natural History museums are often the basis of numerous studies in taxonomy, systematics, ecology, biogeography, management, conservation, etc. (Baird 2010, Drew 2011, Rocha et al. 2014, among others), and studies based on biological museum specimens are to a large degree the basis of our understanding of the diversity of life on Earth (Drew 2011). Core data associated to stored specimens in biological and paleobiological collections are recognized as fundamental for



discipline-specific research (Pyke and Ehrlich 2010), as well as for broader global issues and public initiatives (Vollmar et al. 2010).

Given the taxonomic, geographic, and temporal range of samples in museum collections, resorting to stored mammal specimens has a number of advantages over using field specimens (Cassey et al. 2010). Because research involving the study of pelage color in mammals is better if it includes a wide-range sample, it may be desirable that such studies resort to specimens stored in museums.

In a recent study (Sandoval Salinas et al. 2016) we addressed the intra-specific pelage color variation in a South American small rodent species (*Akodon budini*, Rodentia: Sigmodontinae). We studied the variation related to sex and season but not to latitude, longitude or altitude, because that rodent species has a latitudinally (and longitudinally and altitudinally) restricted area of distribution. At that moment, we hypothesized that pelage color would be more homogeneous in males than in females, but the results did not directly confirm our hypothesis, so we showed the complexity of the studied pattern and we speculated about a possible interpretation of the observed data. Regarding season, we hypothesized that pelage color would be darker in winter than in summer, the latter being orange, and the results clearly confirmed our hypothesis. Finally, we concluded that the studied variables should be considered when studying the coloration of specimens for characterization, identification, and discrimination of different taxonomic units based on color.

In another more recent study (Sandoval Salinas et al. 2018) we addressed the question of pelage color variation in *Akodon budini* specimens stored in one museum collection for different periods of time. As other colors of the animals, pelage color is susceptible to deterioration with time due to chemical or structural degradation of pigments that may result in the alteration of their optical properties (Cassey et al. 2012). This effect has been acknowledged explicitly as a possible limiting factor in research on collection material (Davis and Castleberry 2010, Davis et al. 2013). In that study, we observed that there is a relationship between specimen storage antiquity and pelage color and that it seems that this relationship is general for at least a number of small mammals; therefore, this could indicate a universal phenomenon across several mammal species and across several storage conditions.

The main goal of the present study was to analyze objectively measured color data from a taxonomically wide sample of several small mammal species, to identify, if any, common patterns of color changes in the pelage of specimens of small rodents, in relation to a biological (specifically, sex) and some environmental (specifically, those related to season and latitude, longitude, and altitude) variables. We also included the sample antiquity as a variable under study in order to test previously described pelage color change patterns.

## **MATERIALS AND METHODS**

The studied sample includes several rodents species housed in The Field Museum (FMNH, Chicago, USA) and the Smithsonian National Museum of Natural History (NMNH, Washington, DC, USA) Mammals Collections. In the FMNH, we measured the pelage color by taking five measurements on each one of three points over the dorsal and ventral surfaces of 300 specimens, using an Ocean Optics USB2000+. In the NMNH, we took the color data through three measurements on each one of three points over the dorsal and ventral surfaces of 93 specimens, using an X-Rite eXact spectrophotometer.

From the 300 studied FMNH specimens, we present the results obtained for 16, in eight pairs selected so that the two specimens of each pair ideally differ in the status assignment of one variable: sex (male / female), season (June: winter / December: summer), latitude (relatively high / low), longitude (relatively high / low), and altitude (relatively high / low). In addition, we tested the variation of the pelage color associated with the storage antiquity of the specimen (older / more recent). Due to the characteristics of the sample, it was not possible to select a pair of with significative difference only in the assignment status of the latitude variable, and therefore we selected three pairs of specimens to study the variation associated with that variable: one pair differs only in the assignment status of the latitude but the difference is only 0.5°, while the other two pairs have a considerable difference in the latitude of collection locality (approximately 2° and 3°) but also differ in the assignment status of the altitude variable.

Meanwhile, of the 93 studied NMNH specimens, we present the results for a subsample of 74 of them, selected for presenting intraspecific variation in the assignment status of at least one variable.

We analyzed each instrument data set separately. We used the R package “pavo” for visualizing and organizing of spectral data obtained with the Ocean Optics USB2000+. Prior to performing the analysis, records corresponding to the region of ultraviolet (below 380 nm wavelength) and infrared (above 780 nm) were removed from the databases. For CIELAB data obtained with the X-Rite eXact spectrophotometer, we used principal component analysis to describe the association between the color variables ( $L^*$ ,  $a^*$ , and  $b^*$ ), the independent variables (sex, season, latitude, longitude, altitude, month, and storage antiquity), and each one of the observations, and we then used analysis of variance general linear models to examine relationships between color data and all the variables involved.

## RESULTS

### Spectral data

Graphs corresponding to the visible range reflectance spectra of the eight pairs of reference specimens are shown in Figures 1, 2, and 3.

In Figure 1a, we graph the reflectance spectra of specimens FMNH 162657 and 162683 (one male and one female of *Akodon albiventer*, respectively, collected in August, 1997, in Basin E Lago Poopo, 4 km by rd. N Huancane, Oruro, Bolivia). As our and other previous studies pointed out, pelage color does not appear to significantly vary in relation to the specimens sex. Similarity in coloration seems particularly evident in the ventral zone (white), while in the dorsal area (brown) a certain level of dissimilarity can be seen. In Figure 1b, we graph the reflectance spectra of specimens FMNH 30110 and 34999 (two females of *Akodon simulator* collected in June and December, respectively, 1926, in Concepción, Tucumán, Argentina). Here it can be seen that the ventral surface (grayish white) seems notably different between the specimen collected in winter, which has a higher percentage of reflectance at all wavelengths, and the specimen collected in summer.

In Figures 2a, b, and c, we graph the reflectance spectra of specimens FMNH 46121-23360 (two males of *Akodon budini*, collected in June, 1921-3, in Higuierillas and in Mountains W of Yala, respectively, in Jujuy, Argentina), FMNH 46147-30188 (two males of *Akodon spegazzinii tucumanensis*, collected in June-July, 1929-6, in La Represa, Metán, Salta, and in Concepción, Tucumán, respectively, in Argentina), and FMNH 23379-30194 (two females of *Akodon puer caenosus*, collected in June-August, 1923-6, in Mountains W of Yala, Jujuy, and in Concepción, Tucumán, respectively, in Argentina), respectively. In all cases, similarity in coloration seems particularly evident

in the ventral zone (different shades of brown), while in the dorsal area (other different shades of brown) a certain level of dissimilarity can be seen in relation to latitudinal relative position, having the northern specimen higher percentage of reflectance at all wavelengths in two of the three studied specimen pairs.

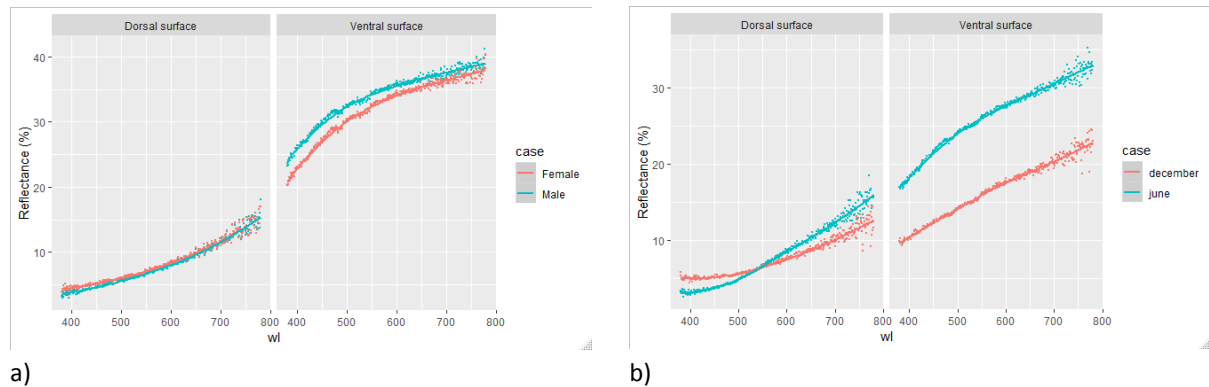

Figure 1: Spectral data of the dorsal and ventral surface of four FMNH small rodent specimens: Reflectance spectra. a) Specimens of *Akodon albiventer* that differ in their sex: one male (FMNH 162657) and one female (FMNH 162683). b) Specimens of *Akodon simulator* that differ in their collection season: one having been collected in winter (FMNH 30110) and one having been collected in summer (FMNH 34999).

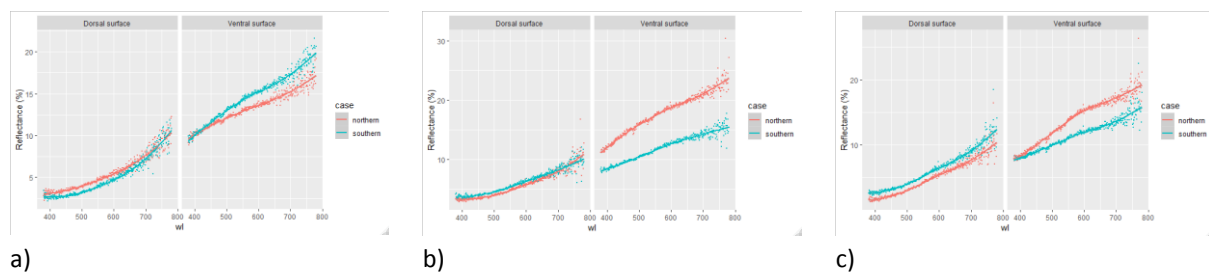

Figure 2: Spectral data of the dorsal and ventral surface of six FMNH small rodent specimens: Reflectance spectra. a) Specimens of *Akodon budini* that differ in the latitude of their collection localities: a relatively more northern specimen (FMNH 46121) and a relatively more southern specimen (FMNH 23360). b) Specimens of *Akodon spegazzinii tucumanensis* that differ in the latitude and also in the altitude of their collection localities: a relatively more northern specimen (FMNH 46147) and a relatively more southern specimen (FMNH 30188). c) Specimens of *Akodon puer caenosus* that differ in the latitude and also in the altitude of their collection localities: a relatively more northern specimen (FMNH 23379) and a relatively more southern specimen (FMNH 30194).

In Figure 3a, we graph the reflectance spectra of specimens FMNH 46142 and 46161 (two males of *Akodon toba*, collected in September-June, 1929, in Avia Terai, Chaco, and in La Represa, Metán, Salta, respectively, in Argentina). In this case, pelage color does not appear to significantly vary in relation to the longitude of the specimen collection localities. In Figure 3b, we graph the reflectance spectra of specimens FMNH 46143 and 74875 (two females of *Akodon fumeus* collected in April-July, 1928 and 1953, respectively, in Yungas del Palmar and Choro, Ayopaca, respectively, in Cochabamba, Bolivia). Here it can be seen that the ventral surface (lighter brown) seems different between the more recent and the older specimen, the latter having a higher percentage of reflectance at all wavelengths as we expected.

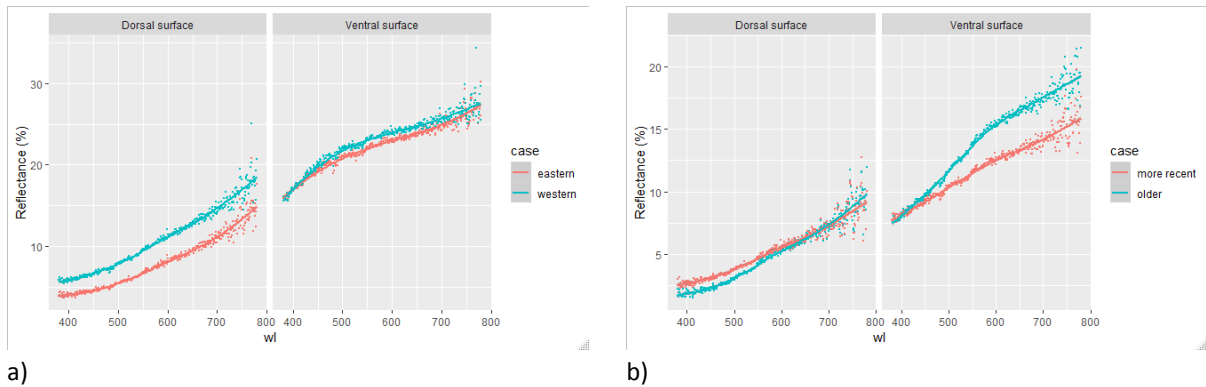

Figure 3: Spectral data of the dorsal and ventral surface of four FMNH small rodent specimens: Reflectance spectra. a) Specimens of *Akodon toba* that differ in the longitude of their collection localities: a relatively more eastern specimen (FMNH 46142) and a relatively more western specimen (FMNH 46161). b) Specimens of *Akodon fumeus* that differ in their storage antiquity: one having been collected in 1928 (FMNH 46143) and one having been collected in 1953 (FMNH 74875).

### CIELAB data

From the T-test (for paired samples) and ANOVA, both for the data of the ventral and the dorsal surfaces of the specimens, it follows that the three measurements for each point are not different from each other, so for subsequent analyzes those measurements are averaged. On the contrary, the three points of each surface of each specimen, are different from each other (the three colorimetric variables,  $L^*$ ,  $a^*$  and  $b^*$ , being significantly different on the back, and two of the three,  $a^*$  and  $b^*$ , on the belly), so the points cannot be averaged to obtain a single tri-stimulus value per specimen, and for subsequent analyzes three points per specimen are maintained.

Principal component analysis results are shown in Figures 4 and 5. On average, the first two components summarize approx. 60% of the variation observed in the colorimetric data (Figure 4). However, none of the studied variables have high (greater than 0.50) settings with these axes. For all three points, sex has high fit values with component 3, season (= month) with component 4,  $L^*$  and sample antiquity with component 6, latitude and longitude with component 7, and  $a^*$  and  $b^*$  with component 8 (data not shown).

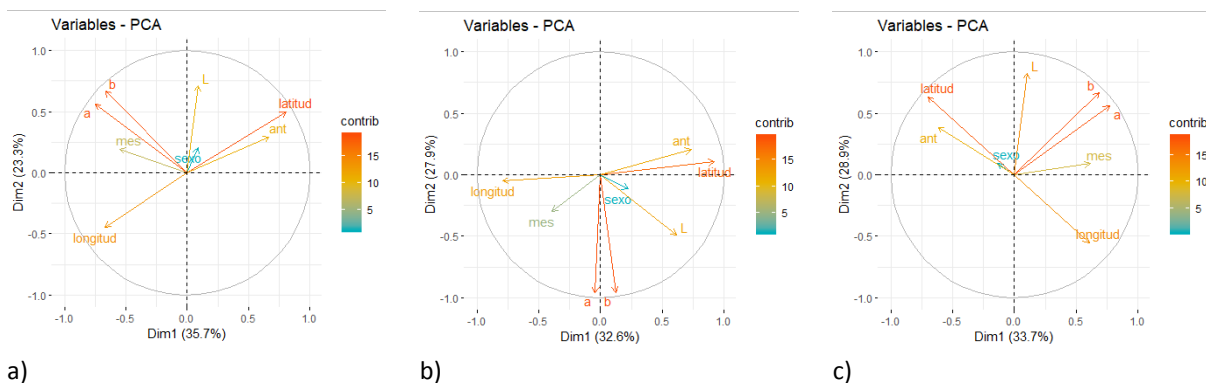

Figure 4: CIELAB data of the dorsal surface of NMNH small rodent specimens: principal components analysis: a) Point #1. b) Point #2. c) Point #3.

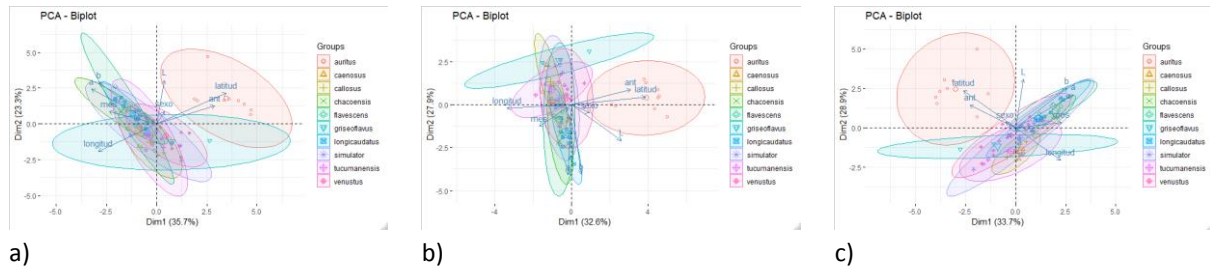

Figure 5: CIELAB data of the dorsal surface of NMNH small rodent specimens: principal components analysis. Biplot of species polygons. a) Point #1. b) Point #2. c) Point #3.

Analysis of variance results for the three points on the dorsal surface of the specimens are presented in Table 1. Between the studied variables, the species and the collection season (= month) determine significant differences in all cases. In relation to geographical coordinates, longitude determines significant differences for the variable L\* at the three measured points and latitude determines significant differences for L\* at points #2 and #3, and also for a\* at point #2. On the other hand, sample antiquity determines significant differences for L\* at points #2 and #3 and also for a\* and b\* at point #3 (Table 1).

	Point #1			Point #2			Point #3		
	L*	a*	b*	L*	a*	b*	L*	a*	b*
Season	0.0022	0.0069	0.0149	0.0002	0.0046	0.0339	0.0021	0.0002	0.0001
Latitude	0.0829	0.0551	0.3081	0.0006	0.0103	0.1004	0.0024	0.2919	0.2573
Longitude	0.0157	0.0995	0.184	<0.0001	0.7332	0.7695	0.0189	0.6411	0.4897
Antiquity	0.6426	0.1636	0.2151	<0.0001	0.1844	0.1213	0.0008	0.0356	0.0076
Species	0.0354	<0.0001	<0.0001	0.0007	<0.0001	<0.0001	0.0001	<0.0001	<0.0001
Sex	0.1396	0.6871	0.42	0.6581	0.3616	0.091	0.1785	0.2499	0.1373

Table 1: CIELAB data of the dorsal surface of NMNH small rodent specimens: p-values associated with the F-statistic from a Type I SC ANOVA.

### CONCLUSION

This study shows a number of relationships and associations between individual pelage color variation and a biological (specifically, sex) and some environmental variables (specifically, those related to season and latitude, longitude and altitude) that are common to a number of rodent species specimens. In relation to sample antiquity, our preliminary results seems to support previously described pelage color change patterns. As might be expected, the situation is complex and deserves to be analyzed with care, although some interesting common patterns emerge.

### ACKNOWLEDGEMENTS

We are very grateful to the curators of the museum’s mastozoological collections: Dr. Bruce Patterson (MacArthur curator of mammals, The Field Museum of Natural History, Chicago, USA) and Dr. Don Wilson (emeritus curator of mammals, Smithsonian National Museum of Natural History, Washington, DC, USA) for allowing MLSS to access to the collections under their custody and to study

the specimens stored there. We are also grateful with the bird division staff, who provided MLSS with the equipment for taking colorimetric data in the FMNH, and with Dr. Catharine Hawks (conservator, collections program, NMNH) and her team, who welcomed and provided MLSS with the equipment for taking data in the NMNH. MLSS wants to thank Smithsonian Institution for her academic appointment (short term visitor) as Smithsonian fellow in the Smithsonian's National Museum of Natural History, Washington, DC, USA, between November 27 and December 1, 2017, which allowed her obtaining the data of the specimens stored in that museum. Finally, we want to thank Luciana Castillo (ILAV-CONICET) for her invaluable help with statistical analyses.

## REFERENCES

- Baird, R. 2010. Leveraging the fullest potential of scientific collections through digitization. *Biodiversity Informatics* 7: 130-136.
- Cassey, P., G. Maurer, C. Duval, J. G. Ewen, and M. E. Hauber. 2010. Impact of time since collection on avian eggshell color: A comparison of museum and fresh egg specimens. *Behavioral Ecology and Sociobiology* 64: 1711-1720.
- Cassey, P., M. E. Hauber, G. Maurer, and J. G. Ewen. 2012. Sources of variation in reflectance spectrophotometric data: A quantitative analysis using avian eggshell colours. *Methods in Ecology and Evolution* 3: 450-456.
- Davis, A. K., and S. B. Castleberry. 2010. Pelage color of red bats *Lasiurus borealis* varies with body size: an image analysis of museum specimens. *Current Zoology* 56: 401-405.
- Davis, A. K., N. Woodall, J. P. Moskowitz, N. Castleberry, and B. J. Freeman. 2013. Temporal change in fur color in museum specimens of mammals: reddish-brown species get redder with storage time. *International Journal of Zoology* 876347. <https://doi.org/10.1155/2013/876347>.
- Drew, J. 2011. The role of natural history institutions and bioinformatics in conservation biology. *Conservation Biology* 25: 1250-1252.
- Pyke, G. H., and P. R. Ehrlich. 2010. Biological collections and ecological/environmental research: a review, some observations and a look to the future. *Biological Reviews of the Cambridge Philosophical Society* 85: 247-266.
- Rocha, L. A., et al. 2014. Specimen collection: an essential tool. *Science* 344: 814-815.
- Sandoval Salinas, M. L., R. M. Barquez, E. M. Colombo, and J. D. Sandoval. 2016. Intra-specific pelage color variation in a South American small rodent species. *Brazilian Journal of Biology* 77: 1-11.
- Sandoval Salinas, M. L., J. D. Sandoval, E. M. Colombo, and R. M. Barquez. 2018. The pattern of color change in small mammal museum specimens: Is it independent of storage histories given museum-specific conditions? *BMC Research Notes* 11: 424. <https://doi.org/10.1186/s13104-018-3544-x>.
- Vollmar A., J. A. Macklin, and L. S. Ford. 2010. Natural history specimen digitization: challenges and concerns. *Biodiversity Informatics* 7: 93-112.

# Appendix



## Posters that received the Robert W. G. Hunt Poster Award (provided by The Colour Group, Great Britain)

The Colour Group (Great Britain) offered three Robert W. G. Hunt Poster Awards at AIC 2019. Each one of the selected posters was awarded a certificate and a GB£ 100 prize.

The Robert W. G. Hunt Poster Award is designed for the best presentations in poster format on the topic of color at selected conferences and exhibitions. There are no specific geographic requirements. The judging is undertaken by members of the scientific committee attending the conference, including a member of The Colour Group (GB).

In the AIC 2019 Conference in Buenos Aires, the following aspects were taken in consideration to evaluate the posters:

- a) Quality of content: Contribution to the field / Originality  
Method  
Results
- b) Quality of design: Proper use of color  
Formal organization  
Visual impact  
Legibility
- c) Relevance regarding the conference theme: “Color and Landscape”

By looking and analyzing the 46 posters exhibited at the conference, each one of the 18 members of the evaluation committee selected from 5 to 7 posters according to the above criteria, and rated them on a scale from 5 (good) to 10 (excellent). The results were tabulated, and the three most voted posters, with the higher evaluation notes (7 or more votes out of 18 committee members, and a total score above 55 points), were extracted from that. These posters were:

**poster G3. Glenn McArthur: Local colour and patterns**

(exhibited in the “Color Education” section; see also the full paper in this book)

**poster B2. Yen-Ching Tseng, Yuh-Chang Wei, Monica Kuo, Ya-Ping Kuo, Wen-Guey Kuo:**

**A case study on environmental landscape color harmony via the Zhengbin Fishing Port color scheme**

(exhibited in the “Urban Landscape” section; see also the full paper in this book)

**poster C2. Ana Torres-Barchino, Juan Serra-Lluch, Anna Delcampo-Carda:**

**Chromatic applications in interior spaces for the elderly in the P. Borja Geriatric Center of the Fontilles Foundation**

(exhibited in the “Environmental Color Design” section; see also the full paper in this book)



# Local Colour & Patterns

Glenn McArthur: OCAD University, Toronto, Canada

**Objectives:** This project encouraged students to think about colour and patterns from specific geographic and cultural locations and how local colour may be used in contemporary design, evoking and celebrating the essence of a place.

This is a first year project for design students in a *Colour and Two-Dimensional Design* course. It consisted of three phases: first, students selected a geographic location and conducted visual research on it from both the internet or their own images. Next, they uploaded those images to a colour identification website and extracted the colour information. For the second phase, students were instructed to create a composition that was atmospheric or abstract

in nature, using the colour palette they had extracted, which they were then to use as a background for their final design. Additional research was conducted to find decorative patterns from their sites' local environment (plants, animals, built forms, etc.) and then transform it into a contemporary design. For the final phase, students combined their abstract image and pattern into one design and then applied it to either a 2D or 3D object or surface.

Comments? Please share any thoughts by email, [gmcArthur@faculty.ocadu.ca](mailto:gmcArthur@faculty.ocadu.ca) or [glennmcarthur@gmail.com](mailto:glennmcarthur@gmail.com)

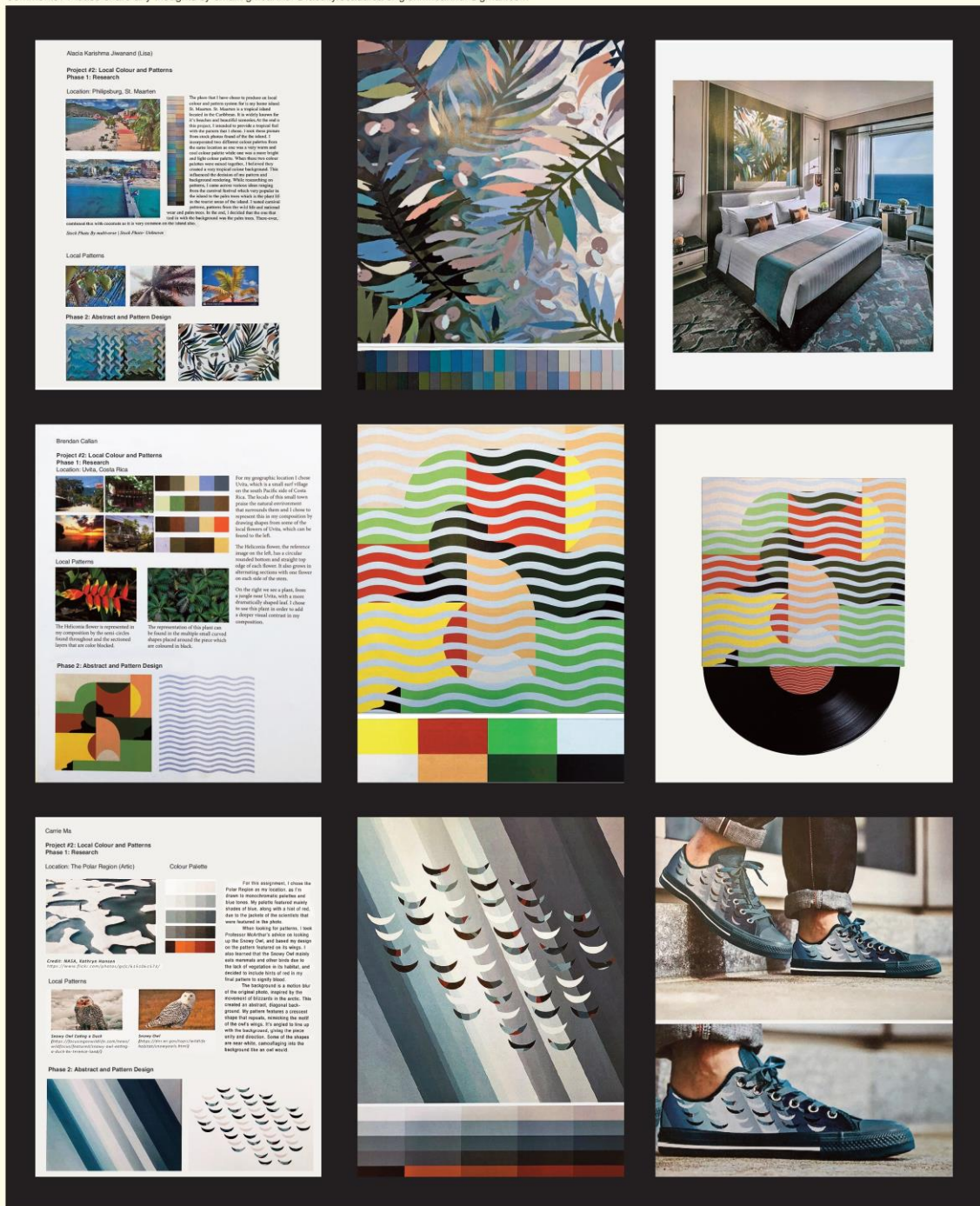



NAME and INSTITUTION  
**Yen-Ching Tseng\***, Yuh-Chang Wei\*, Monica Kuo, Ya-Ping Kuo, Wen-Guey Kuo  
 Chinese Culture University, Taipei, Taiwan  
 \*yenching.tseng@gmail.com, ycwei@faculty.pccu.edu.tw

POSTER TITLE  
**A Case Study on Environmental Landscape Color Harmony via the Zhengbin Fishing Port Color Scheme**

FIELD & TOPIC  
 Environmental color design - Urban landscape

KEYWORDS  
 environmental landscape color color harmony color scheme NCS environmental color survey tool subjective environmental color analysis

ABSTRACT  
 The purpose of the study is to analyze the significance of environmental landscape color harmony via the Zhengbin Fishing Port Color Scheme. A multi-color combinations façade of the seafont architecture complex is the target color scheme. A scientific NCS environmental color survey conducted to collect regional colors and to establish an environmental color database. A subjective environmental color analysis evaluated by the color planner to develop a color planning strategy. Based on the principle of color harmony, the color planner designed a multi-color combinations scheme by selecting domain colors and increasing color contrast in compliance with proper lightness, chroma, environment context, and color composition to fulfill the project's objective. The overall performance of the color scheme perceived quite harmonious with environmental landscape colors. Indeed, it was not only to enhance the Zhengbin Fishing Port's regional characteristics and cultural style successfully, but also to become a visual landmark as well.

ACKNOWLEDGMENTS  
 It is highly appreciated that all the information and materials of color project, funded by the Keelung city government, provided for this research is overwhelmingly. The photos used in this article by courtesy of the photographers are very grateful as well, including famous Mr. Min-Ming Chen, etc.

**Introduction**

The aim of this case study is to reveal the significance of color harmony scheme by renovating a new multi-color combinations façade of the seafont architecture complex (Figure 1) in order to create a visual landmark on local environmental landscape.

The color scheme project, funded by city government, of the nostalgic pier of Zhengbin Fishing Port, located at Keelung city harbor in Northern Taiwan. The color project team was led by the architect.

The objectives of color planning strategy is to maintain the balance between the color imagery of harbor city and Zhengbin Fishing Port area, to achieve "colorful diversity", and to develop a proper color scheme to enhance regional characteristics and cultural style of the Zhengbin Fishing Port.



Figure 1: The original façade (a rectangular area) of seafont architecture complex is the target color scheme (left). Geographical location of Zhengbin Fishing Port, located at Keelung city harbor in Northern Taiwan.

**Methods**

**Environmental colors data analysis**

The color scheme, based on Jean-Philippe Lenclos's methodology of color geography, began with an investigation of the local colors using NCS environmental color survey tool.

The domain colors of environmental landscape in Zhengbin Fishing Port region were collected and analyzed in NCS chromatograms. An environmental color dataset established for the color scheme. (Figure 2)

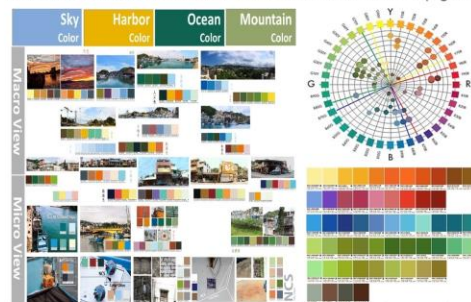

Figure 2: An environmental color survey conducted to investigate the regional landscape colors (left). An environmental color dataset established for the color scheme (right).

**The color scheme planning & implementation**

1. The collaborative discussions held by stakeholders, experts, scholars and the color planner to determine medium-high lightness and chroma of colors (warm colors) with higher contrast as the key tone for the color façade of architecture complex at Zhengbin Fishing Port.

2. A proposed color scheme was designed by the color planner, based on color harmony scheme principle.

3. The final approval of color selection of each building was decided by the residents. Owner of houses, 523, 527, 529, 537, 551, 561, chose their preferred colors rather than the color planner's recommendation.

A multi-color combinations scheme for the seafont architecture complex's façade is shown on Figure 4. It was found that color differences existed between NCS color patches and actual color paints.



Figure 3: A multi-color combinations scheme designed for the façade of the seafont architecture complex.

**Results**

The color harmony analysis (Figure 4) for the Zhengbin Fishing Port color scheme has shown the overall performance of color combinations on the color scheme perceived quite harmonious in accordance with color harmony scheme principles.

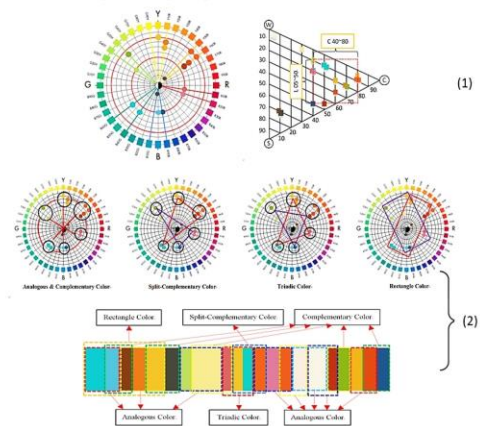

Figure 4: (1) The distributions of each selected color hue, chroma and lightness are plotted and analyzed by NCS Colour Circle and Triangle. (2) Color harmony schemes analyzed in two, three, four and multiple colors combinations.

**Discussions**

1. The Jean-Philippe Lenclos's methodology of color geography adopted into this project proved very effective and successful. Due to the environment limitations, a perfect color harmony scheme for the façade might be hardly to be achieved, but the overall performance of multi-color combination color scheme perceived quite harmonious with environmental landscape colors, see Figure 5.

2. This project set up a good example that the colors selection for color scheme was decided according to collaborative discussions among stakeholders, experts, scholars and the color planner.

3. The final approval of color selection for each building was determined by the residents, not by the color planner or the city government administrators. Personal color preference turned out to be a significant factor influencing the color harmony of color scheme.

4. The communication between stakeholders and the color planner regarding the consensus of color selection for the architecture complex on the color scheme needs to be further improved.

5. It is to suggest that the psychophysics experiment method could be adopted to support the rationale of multi-color combinations scheme as additive for the color planner's aesthetical design.



Figure 5: Keelung city government tourist website and popular photos posted by courtesy of the photographers.

**Conclusions**

Zhengbin Fishing Port color scheme has captured public attention and compliments after the implementation of project. It has become a new landmark and tourist attraction, which known as "Zhengbin Color Houses" that inspired from the Italy Venetian Island of Burano (colorful island).

**References**

Hård, A.; Sivik, L. & Tonnquist, G. 1996. NCS Natural Color System - from Concepts to Research and Applications. Part I and II. *Color Research and Application*. 21: 180-220.  
 Lenclos, J. 1999. *Couleurs du monde*. Moniteur, Paris.  
*Natural Color System*,  
[https://en.wikipedia.org/wiki/Natural\\_Color\\_System](https://en.wikipedia.org/wiki/Natural_Color_System)





BUENOS AIRES

NAME and INSTITUTION

Ana Torres-Barchino,  
Juan Serra-Lluch,  
Anna Delcampo-Carda

Grupo de Investigación del Color en  
Arquitectura, Instituto de Restauración del  
Patrimonio, Universitat Politècnica de València,  
Spain

POSTER TITLE

CHROMATIC APPLICATIONS  
IN INTERIOR SPACES FOR  
THE ELDERLY IN THE P.  
BORJA GERIATRIC CENTER OF  
THE FONTILLES  
FOUNDATION

FIELD & TOPIC

Environmental color design  
Architecture and landscape

KEYWORDS

color, architecture, interior design, elderly,  
space.

ABSTRACT

The interior space in architecture is one of the most important concepts throughout the history of architecture. There are many characteristics that define the three-dimensional aspects of space in order to obtain a more habitable place. This communication is focused on a particular chromatic study, carried out in three interior spaces at the P. Borja Geriatric Center of the Fontilles Foundation (Alicante), where the appropriate chromatic modifications have been made to achieve improvements in their habitability. This Geriatric Center is specialized in the care of elderly people with varying degrees of dependency. This study is part of a research project carried out by the UPV Architecture Color Group, approved by the Ministry of Industry and Competitiveness of the Spanish Government (2016-2019). The aim of this research project is to establish parameters and chromatic modifications in built interior spaces of the public centers of the Valencian Community, where older people live.

ACKNOWLEDGMENTS

This paper is framed within the activities of the research project "Modifications of the Visual Comfort in Residential Centers to improve the Quality of Life for the Elderly" funded by the Ministerio de Economía y Competitividad de España.

REFERENCES

- Alnoorthy, 1989. Color in the work environment.
- Dalke, J., Little, E., Niemann, N., Camargo, G., Steadman, S., Hill, and L. Stott, 2006. Colour and lighting in hospital design. Opt. Laser Technol. 38(4-6), 343-365
- Delcampo-Carda, A., Torres-Barchino, A. and Serra-Lluch, J., 2019. Chromatic interior environments for the elderly: A literature review. Color Research & Application, 44(3), 381-395.
- Fundación Fontilles. Geriátrico Borja Online: <https://fundacionfontilles.org/centro-geriatrico-borja/>
- GICA (Grupo de Investigación del Color en Arquitectural Online: <https://grupocolor.webs.upv.es/>, Universitat Politècnica de València, España.
- Delcampo Carda, A., Torres Barchino, and J. Serra Lluch, 2016. El color como estrategia para mejorar la orientación y capacidad sensorial en la arquitectura destinada a personas mayores. In: Dibujar, Construir, Soñar: Investigaciones en torno a la expresión gráfica aplicada a la edificación. Castellón: Trazo Lo Blanco, 229-244.
- Llopis, J., 2017. Arquitectura y paisaje en el Sanatorio de Fontilles. Col. Universitat Politècnica de València.
- Mahnie, F. and Mahnie, R., 1987. Color and light in man-made environments. New York: Van Nostrand Reinhold Company.
- Torres Barchino, A., Serra Lluch, J., Llopis Verdo, J. and Delcampo Carda, A., 2017. Studies on Color in Residential Architecture for the Elderly. In: 13th International AIC Congress: Being Color with Health, 16-20 October 2017, Youn Jin Lee, J. H. and Hyoun Jong Suk, Y. K. P. eds. ICC jeju, 0503-04.
- VVAIA MODIFICA. 2019. National Research Project: Modificaciones del confort visual en centros residenciales para la mejora de la calidad de vida de las personas mayores. Valencia, España: (AE/FEDER, UE).

The facilities of the P. Borja Geriatric Center of the Fontilles Foundation (Alicante) present certain architectural features that can be studied because it is a building located in a unique natural landscape, and it offers a climate especially suitable to accommodate people with certain dependency. It is a very different place from other centers that have been built in an urban area. P. Borja Geriatric Center, that was constructed also at the beginning of the 20th century, is a benchmark of social compromise, where various studies on health and wellness are carried out.

In this context, the study focuses, firstly, on an analysis of the original color of the most common rooms of this center and, secondly, on the elaboration of new chromatic proposals that allow to improve the interior spaces. The spaces analyzed in this study are, today, the most used by residents in their daily lives: a multipurpose room where group activities are carried out, a corridor and its transit to other rooms, and a standard bedroom. All the chromatic modifications have been made in this pilot center.

THE P. BORJA GERIATRIC CENTER: CASE STUDY 01



Figure 1: Current state of the P. Borja Geriatric Center, in Fontilles, Alicante. Location and relationship with the natural environment.

THE PILOT CENTER: CASE STUDY 02

PREVIOUS STUDIES



Figure 2: Focus Groups conducted in small groups of older people, to know their visual status and color preferences.

VIRTUAL REALITY



Figure 3: Test conducted to residents and staff of the P. Borja Geriatric Center. Visualization by Virtual Reality glasses of the images of the rooms best known by the resident: multipurpose room, corridor and bedroom.

RESULTS 03

BEFORE CHROMATIC INTERVENTION



	NCS COLOR
Walls	S0804-Y10R
Doors	S3020-G80Y
Carpentry	S7020-G
Wardrobe	S3020-G80Y

	NCS COLOR
Walls	S0804-Y10R
Doors	S3020-G80Y
Carpentry	S7020-G
Handrail	S7020-G

	NCS COLOR
Walls	S0520-Y20R
Doors	S3020-G80Y
Carpentry	S7020-G

AFTER CHROMATIC INTERVENTION



	NCS COLOR
Walls	S0520-R90B
Doors	S2040-R90B
	S3050-R90B
	S1015-Y30R
Doors	S2040-R80B
Carpentry	3050-R90B
Wardrobe	S1020-Y40R
	2040-R80B

	NCS COLOR
Walls	S0520-R90B
	S2040-R90B
	S3050-R90B
Doors	S1020-Y40R
Carpentry	3050-R90B
Handrail	3050-R90B

	NCS COLOR
Walls	S0520-R90B
	S2040-R90B
	S1015-B20G
	S1015-Y80R
Doors	S3040-R80B
Carpentry	S3050-R90B

Bedroom

Corridor

Multipurpose room

Figure 4: Before and after the chromatic intervention. Final result.

It should be noted that, before the chromatic intervention, the interior of the center was characterized, in its entirety, by the typical uniform yellow color in all its walls, and a dark green color in the metallic details such as handrails, carpentry and other elements of design. These colors these colors promoted a hospital image that did not follow any type of study or habitability conditions. Thus, it has been necessary to carry out an exhaustive analysis that allows to elaborate a color chart determined by the organization of the space, the type of activity that is carried out in each area, as well as the need to achieve more current spaces that help bring the residents closer to social proximity. A final objective of this study, is to establish chromatic modifications that help the perceptual improvement of residents (Torres-Barchino et al. 2017). To do this, as a previous phase to the chromatic intervention in real spaces, two types of analysis are established: firstly, to determine the visual state of the elderly through a deep literature review (Delcampo-Carda et al. 2019) as well as objective tests (focus group) carried out in small groups of elderly people aged between 70 and 90 years (VVAIA MODIFICA. 2019) (Fig. 2).

The conclusions drawn in this first theoretical-practical analysis determined the second phase of the analysis, that is, the design consisting of a test based on images, of the rooms best known by the residents, visualized by Virtual Reality glasses in their original chromatic state and the same images modified in other color schemes previously selected by residents (Fig. 3). In these images, 4 different color schemes (mainly based on value and contrast modifications) of the three specific rooms were shown. Subsequently, the test aimed to collect the responses about the best perception of the spaces and the particular chromatic preference before carrying out the painting process in the center's facilities. For this, a questionnaire is prepared for each participant, consisting of 3 different parts, based on the evaluation of the three main real spaces existing in the Geriatric Center. Each of these spaces is presented individually. The chromatic proposals offered in this study for these spaces by using the new technologies of Virtual Reality, have given the possibility to visualize and select chromatic compositions before painting them. The combinations have been defined as a result of the previous study through geometric forms that suggest harmony and dynamism, as well as the unquestionable participation of the older residents and the staff.

As a result, various compositions were designed with geometric shapes and color variations between warm and cold colors (Fig. 4). The difference of each one of the spaces studied, does not depend only on its dimensions, but on the lighting (natural light entrances and artificial light points). Furthermore, the route that the resident makes during the day, will be a fundamental characteristic to determine any variation or color approach in the whole space.

Analysis of the spaces according to uses and times, main objectives:

- To perceive and generate an attention space for transit time: corridors.
- To perceive a balanced space for resting time: bedroom.
- To perceive a dynamic space for action time: activity or multipurpose room.

The result of this work has been carried out in the facilities of the P. Borja Geriatric Center for three years and culminates during this year 2019. The implementation of the color chart and its application in the indicated spaces, has demonstrated a new perception of them in the Case Study Center, in which both residents and staff participated in the process in the different compositional designs intended for this place.

This Research Project, leads to the reflection of the study and application of color, as well as the idea of generating designs that help to improve the original built spaces whose modifications allow a more friendly habitat, improving the quality of life of older people with certain degrees of dependency. Likewise, we believe that a common color chart cannot be established for all buildings of this type. The particular study for each type of center must be considered based on its own characteristics, as well as knowing the state of the people who inhabit them.

CONCLUSIONS

Currently, the residents of the center show a more positive mood after the color intervention in the inhabited spaces. The activity-multipurpose room as a group room and game room, has managed to improve the attitude of the resident. It is still too early to draw definitive conclusions. These conclusions should be determined throughout the rest of this year to assess the satisfaction results of resident users.

In short, our study is a pioneer in this type of experience in the Valencian Community, so a theoretical-graphic document has been prepared as a result of the tests based on the organization of color in residential spaces that will soon be revealed in a "White Paper", especially indicated to designers and architects.



BUENOS AIRES

## Exhibition: Color exercises by graphic design students of Dutch art faculties

by Julieta Garavaglia

Offset printed matter color exercises made by graphic design students of Dutch art faculties (ArtEZ Arnhem and Academie St. Joost Breda) between 1994 and 2002.

The exhibition took place on 17 October 2019, at the ground floor of the Universidad de Belgrano.



## Exhibition: The Biosphere Project

by Joaquín Fargas

The mission of The Biosphere Project is to raise awareness on the fragility of our planet.

The Biosphere Project stands as a platform to raise awareness about the issue of Earth preservation, until now, the only possible habitat for human beings to live. In a poetic way the project shows the need to understand nature's properties and to become aware about the importance of this issue. It deals with contemporary art as an instance to develop a constructive criticism of our own context.

### Description

Spheres, completely sealed, contain a natural and complex ecosystem. They are shown as a metaphor of the planet on an infinitesimal scale. These spheres are made of glass, polycarbonate or Plexiglas and are placed on stands of different designs and height made of stainless steel, iron, aluminum, or just hanging from the ceiling. Interactive modules include documentary information about different ecosystems and about the living forms inside the biospheres. The interaction between the art craft and the environment is relevant. The life on the biospheres depend on the location in which they are placed, variables like temperature and the amount of light are critical for them to survive.

### Scope of the project – Brief overview

In December 2006, the Biosphere Project was launched in Buenos Aires, and by March 2007 the project was presented in several cities of Argentina. In May 2007 it was shown for the first time in Latin America, at a Red Pop Convention in San Jose de Costa Rica, and in June 2008 it was presented at a local level in the V Science Centre World Congress in Toronto, Canada. In the next years, the project was implemented in Argentina, Costa Rica, United States, South Africa, Czech Republic, Canada, Malaysia, Uruguay, Saudi Arabia, Portugal, Sweden, Spain, and Cuba.

**More info:** <https://www.youtube.com/user/joquinfargas#p/u/11/47kDldgB1rE>  
<http://proyctobiosfera.blogspot.com>



## Index of Authors

- Afonso, José, 421, 441  
 Akiba, Kota, 575  
 Akizuki, Yuki, 614  
 Almeida da Silva, Adriane Borda, 372  
 Alpaerts, Ferre, 177  
 Alvarez Gardiol, Josefina, 168  
 Angelo, Kine, 92, 327  
 Arrarte-Grau, Malvina, 145  
 Balián, Marcelo, 475  
 Baniani, Mahshid, 205  
 Barberia-Roque, Leyanet, 634  
 Barboza, Marcos, 475  
 Barquez, Rubén M., 639  
 Barreiros Duarte, Rui, 363  
 Barrionuevo, Pablo A., 598  
 Bellotti, Natalia, 634  
 Booker, Alex, 92, 327  
 Bouchier, Martine, 544  
 Buera, Pilar, 270, 273  
 Busch, Verónica, 273  
 Caivano, José Luis, 16, 333  
 Calvo Ivanovic, Ingrid, 532  
 Cao, Dingcai, 598  
 Caramelo Gomes, Cristina, 421, 441  
 Cárdenas, Gabriela, 333  
 Caro, Daniela, 99  
 Cauwerts, Coralie, 292  
 Chazarreta, Daniela Evangelina, 255  
 Cheung, Vien, 76, 162  
 Cogan-Krumnow, Anne, 500  
 Colombo, Elisa M., 639  
 Colonna, Carlos, 317  
 Conte, Verónica, 276  
 Contino, Juan Ignacio, 605  
 Cordero-Jahr, Elisa, 99  
 Cortés, César, 273  
 Cortina-Maruenda, Javier, 562  
 Csillag, Paula, 32  
 de Lucas Tron, Alfonso, 153  
 Delcampo-Carda, Anna, 568, 650  
 Delgado, Marjorie, 99  
 Di Sarli, Alejandro R., 357, 402  
 Dias Lay, Maria Cristina, 550  
 Diz de Almeida, Catarina, 421, 441  
 Dorado, Cecilia, 168  
 dos Santos, Cristina, 270, 273  
 Duarte, Imara A. M., 183  
 Echagüe, Leonard, 131  
 Ellwood, Roger, 619  
 Fargas, Joaquín, 652  
 Farroni, Abel, 273  
 Feldman, Julia, 168  
 Fernández-Varela, Aldo, 273  
 Ferraris, Roberto, 475  
 Ferraris, Victoria, 475  
 Ferreira, Nivia B., 561  
 Freire-Costa, Fabiano, 273  
 Futoshi Ohyama, 614  
 Gabilondo, Julieta, 273  
 Gámez Espinosa, Erasmo, 634  
 Gandino, Juana, 333  
 Gao, Ruolin, 228, 234  
 Garavaglia, Julieta, 651  
 Gassler, Cornelia, 340  
 Giglio, María Paula, 15, 289, 324  
 Girelli, María Inés, 369, 418, 475  
 Gor, Sergio, 630  
 Goto, Takahiro, 614  
 Gou, Aiping, 189, 193  
 Griber, Yulia A., 249, 256, 544  
 Guo, Hongyu, 461  
 Harkness, Nick, 14  
 Hatakeyama, Kunihiro, 580  
 Henry, Phil, 304  
 Hirschler, Robert, 20  
 Horiuchi, Takahiko, 223, 575  
 Hough, Guillermo, 270  
 Hsieh, Tsuei-Ju, 508

Hutchings, John, 211  
 Huwiler, Martin, 340  
 Iwamoto, Satoshi, 614  
 Ixtaina, Pablo, 317  
 Jofré, Varinnia, 117  
 Jost, Sophie, 292  
 Jung, Ivar, 249  
 Jutterström, Per, 347  
 Katanozaka, Takuto, 609  
 Kawashima, Yuki, 580  
 Kenny, Sara Leonor, 475, 418  
 Kitaguchi, Saori, 217  
 Kondo, Paru, 223  
 Konno, Atsushi, 580  
 Kooroshnia, Marjan, 488  
 Kuo, Monica, 434, 649  
 Kuo, Wen-Guey, 434, 649  
 Kuo, Ya-Ping, 434, 649  
 Lasagno, Cecilia M., 630  
 Le Duff, Natacha, 500  
 Lee, Gyeonghwa, 162  
 Lee, Jin Hee, 481  
 Lee, Tien-Rein, 13, 508  
 Lee, Wen-Yuan, 508  
 Lin, Jing, 200  
 Liu, Tzu Hao, 211  
 Loder, Marina Mendonça, 448  
 Lombardi, Roberto, 333  
 López, Anahí, 357, 402  
 López, Mabel Amanda, 242  
 Luo, Ming Ronnier, 48, 64, 211  
 Lupinacci, Ana Lucia, 32  
 Luzzatto, Lia, 263  
 Mahyar, Forough, 111  
 Maki, Kiwamu, 428  
 Mally, Edda, 481  
 Mariconde, María Marta, 369, 475  
 Marsden, Jamie, 171  
 Martín, Andrés, 605, 630  
 Martinez Conceição, Sandro, 372  
 McArthur, Glenn, 527, 648  
 Melman, Rocío, 333  
 Michiels, Inez, 177  
 Minami, Mai, 298  
 Mirian, Maryam Alsatat, 111  
 Mizutani, Yoshikazu, 217  
 Muñoz, Javiera, 99  
 Musso, María Luisa, 396  
 Mylonas, Dimitris, 256  
 Nagai, Takehiro, 580  
 Naoumova, Natalia, 372, 448, 468, 550  
 Nasseraldin, Ahmed, 171  
 Nirino, Gabriela, 168  
 Nishi, Shogo, 609  
 Noguera, Mariana, 311  
 Noury, Larissa, 390  
 Novello, Víctor, 630  
 O'Connor, Zena, 41, 513, 520  
 Odetti, Jimena Vanina, 454  
 Ojeda, Beatriz, 475  
 Or, Kazim Hilmi, 197, 239, 626  
 Osborne, Roy, 78  
 Panizzolo, Luis, 270, 273  
 Paramei, Galina V., 256  
 Paroldi Algranati, Ludmila J., 333  
 Pepa, Lorena, 270, 273  
 Pereira, Carla P. A., 183  
 Peres Martins, Vanessa, 468  
 Pernão, João, 311  
 Pinheiro, Ana Paula, 378  
 Pinho Souza, Pedro Felipe, 124  
 Plutino, Alice, 538  
 Pompas, Renata, 263  
 Pucheta, Agustín, 317  
 Queiroz, Francisco, 304  
 Reyes González, Alberto, 454  
 Reyes González, Andrés Enrique, 454  
 Rezende, Anamaria, 561  
 Rizzi, Alessandro, 532, 538  
 Rodrigues da Silva, Francis, 139  
 Rodríguez, Analía, 270, 273  
 Rodríguez, Carlos Mario, 556  
 Rossi, Maurizio, 532, 538  
 Saito, Daisuke, 594  
 Sandoval Salinas, María Leonor, 639  
 Sandoval, José D., 639  
 Sato, Tetsuya, 217  
 Schindler, Verena M., 54, 544  
 Schumacher, Jada, 408  
 Serra-Lluch, Juan, 562, 568, 650

Shrestha, Raju, 586  
Silva, Bárbara, 630  
Silveira, Luciana Martha, 139  
Suárez, Raúl Darío, 369, 384, 475  
Suez, Laura, 475  
Sullivan, Chelsea, 619  
Sun, Pei-Li, 508  
Sun, Yuanbo, 234  
Suzuki, Sumako, 217  
Takahashi, Hiroshi, 594  
Talevi, Lucía, 273  
Tanaka, Midori, 223, 575  
Tang, Tang, 162  
Tashiro, Tomonori, 580  
Teixeira Gnutzmann, Nathalia, 372  
Torimitsu, Toshiki, 298  
Torres-Barchino, Ana, 562, 568, 650  
Tosar, Daniela, 168  
Traversa, Luis P., 402  
Tseng, Yen-Ching, 434, 649  
Viera, Marisa, 634  
Villagrán dos Santos, Nicolás, 273  
Violante, Elisa Teresa, 556  
Walker, Lilian, 105  
Wang, Jiangbo, 189, 193  
Wei, Yuh-Chang, 434, 649  
Westland, Stephen, 162, 171, 200, 304, 351,  
619  
Xia, Guobin, 304  
Xiao, Kaida, 351  
Yaguchi, Hirohisa, 66  
Yamauchi, Yasuki, 580  
Yan, Haiwei, 228, 234  
Yang, Jie, 351  
Yoshizawa, Nozomu, 298  
Yoshizawa, Yosuke, 284  
Zoppi, Carlos Augusto, 384





Colour and  
Landscape

**NCS**<sup>®</sup>  
Natural Color System

UNIVERSIDAD DE  
**Belgrano**  
BUENOS AIRES - ARGENTINA



THE COLOUR GROUP (GB)